

Affordable Housing Acquisition

An Affiliate

The Housing Authority of the City of El Paso, Texas

Requests Proposals for:

REMODELING AND RENOVATION OF 300 UNITS AT VILLA ALEGRE APARTMENTS

Solicitation No. OPS 18-R-0022

<p>Affordable Housing Acquisition an Affiliate of The Housing Authority of the City of El Paso, Texas Gerald Cichon Chief Executive Officer</p>	<p>An Equal Opportunity Employer and Contracting Agency</p>
--	---

REQUEST FOR PROPOSALS (RFP)

The Housing Authority of the City of El Paso, Texas (HACEP) is requesting proposals for:

Remodeling and Renovation of 300 units at Villa Alegre Apartments

Request for Proposal will be available online at 10:00 A.M. Mountain Standard Time (MST) beginning **September 26, 2018**, to view the solicitation. **Refer to Request for Proposal No. OPS 18-R-0022.** This solicitation is only available electronically. To view the solicitation, please visit www.hacep.org/procurement.sstg, and click on the "E-Procurement" link. You will have the opportunity to register and view the solicitation. There is no fee associated with the use of this system.

Interested Contractor/Contractors may do a walk thru to the location to inspect and assess units, and to get better assessment of what is required on the renovation of each unit. Visit is scheduled for October 3, 2018 from 8:30 AM -12:00 PM MST at Villa Alegre Apartments located at 6412 Edgemere Blvd., El Paso, TX 79925 prior to Bid closing. If information is needed prior to your visit to our location, you may contact Ms. Eddie Rocha @ 915-849-3789 or Mr. Juan Pulido @ 849-3695.

A pre-proposal conference will be held on October 10, 2018 at 2:00 PM MST at 5300 E. Paisano Dr. Any questions regarding the RFP may be directed to Ms. Eddie Rocha, at (915) 849-3789 or erocha@hacep.org. If you would like to join in the tele-conference, call (877) 226-9790, access code 9217791.

The closing date and time for receipt of sealed proposals is October 24, 2018 at 3:00 P.M. MST. All proposals shall be submitted in "Sealed Envelopes" and may be delivered or hand carried to: Housing Authority of the City of El Paso Texas, Attn: Ms. Eddie Rocha, Contract Specialist, 5300 E. Paisano Dr., El Paso, Texas 79905-2051

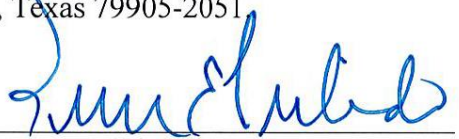

Juan Pulido

Procurement Manager

Advertisement

El Paso Times: **Wednesday: September 26, 2018**
 Sunday: September 30, 2018
 Sunday: October 7, 2018

**Executive Summary Notice
Request for Proposal (RFP)**

Solicitation No.: OPS 18-R-0022

1. The purpose of this Executive Notice is to highlight the key requirements of the Request for Proposal (RFP).
2. Affordable Housing Acquisition, an affiliate of the Housing Authority of the City of El Paso (HACEP), Texas is requesting proposals from qualified Contractor/Contractors to provide Remodeling and Renovation of 300 units at Villa Alegre Apartments. **AHA reserves the right to award multiple Contractors.**
3. **For projects less than ONE HUNDRED THOUSAND DOLLARS (\$100,000.00), the General Contractor may agree to a "TURN-KEY" project option. Performance Bond and Payment Bond will not be required. Therefore, there will be no progressive payments. If ONE HUNDRED THOUSAND DOLLARS (\$100,000.00) and over a Payment and Performance Bonds is required by the Owner.**
4. Affordable Housing Acquisition, El Paso, Texas contemplates award of a contract to Remodeling and Renovation of 300 units at Villa Alegre Apartments. Contractor/Contractors in response to this solicitation will be evaluated using the Technical Proposal Evaluation Process. Contractor/Contractors must submit in accordance with the instructions provided in the Request for Proposal. **Failure to furnish a complete offer at the time and date specified in the solicitation may result in elimination from consideration. Term of this contract is for 70 calendar days not to exceed a total of 70 calendar days.** Liquidated damages in the amount of Two Hundred Dollars and Zero Cents **\$200.00** per day until final completion.
5. Formal communications such as requests for clarifications and/or information concerning this solicitation shall be submitted in writing no later than **October 15, 2018, at 4:00 p.m. MST** local time and directed to **Ms. Eddie Rocha** Contract Specialist, at erocha@hacep.org.
6. **Interested Contractor/Contractors may do a walk thru to the location to inspect and assess units, and to get better assessment of what is required on the renovation of each unit. Visit is scheduled for October 3, 2018 from 8:30AM -12:00PM MST at Villa Alegre Apartments located at 6412 Edgemere Blvd., El Paso, TX 79925 prior to Bid closing. If information is needed prior to your visits to our location you may contact Ms. Eddie Rocha @ 915-849-3789 or Mr. Juan Pulido @ 849-3695.**
7. **Any form of contact by any offeror or potential offeror regarding this RFP, at any time during the solicitation process from initial advertisement through award, with Commissioners of the Affordable Housing Acquisition, El Paso, Texas (AHA) or any person employed by AHA, other than through the communication channels stipulated in the Request for Proposal, or as subsequently instructed by AHA through the solicitation process, will constitute grounds for rejection of their Proposal.**
8. Since AHA is interested in limiting costs associated with the acquisition process, offerors not intending to continue with the RFP are requested to submit a letter requesting they be taken off the mailing list for this solicitation. AHA reserves the right to reject any or all proposals.
9. **Offerors will submit one (1) unbound master copy (so marked) and three (3) copies of their proposal to 5300 E. Paisano as per directed in the Scope of Work. One electronic copy should also be returned on a flash drive to each recipient.**
10. **This solicitation and subsequent amendments shall supersede any posting made through the NAHRO e-procurement system. Potential offerors are advised to review the dates contained in this solicitation in the event of a discrepancy between dates listed in this solicitation and dates listed on the NAHRO e-procurement system.**
11. Thank you for your interest in this project. We look forward to receiving your proposal.

Juan Pulido

AFFORDABLE HOUSING ACQUISITION

RFP OPS 18-R-0022

Remodeling and Renovation of 300 units at Villa Alegre Apartments

Date Issued: September 26, 2018

Subject: Request for Proposal (RFP)

Solicitation No.: OPS 18-R-0022

Separate sealed proposals for Remodeling and Renovation of 300 units at Villa Alegre Apartments for the Affordable Housing Acquisition Inc. will be received at the following address:

Contract Compliance & Procurement Administration

Affordable Housing Acquisition Inc. El Paso, Texas

5300 Paisano

El Paso, Texas 79905 - 2931

3:00PM, MST, October 24, 2018. Proposals will be held in confidence and not released in any manner until after contract award.

For any Contract which requires the Contractor to provide services, the Contractor shall, prior to commencement of work, provide AHA with Certificates of Insurance in the below amounts and shall maintain such coverage in effect for the full duration of the Contract. HACEP must be named as additional insured in the insurance certificate(s).

General Liability	\$1,000,000
Automobile (contractor has vehicles on HACEP premises)	\$1,000,000
Workman's Compensation Insurance (for onsite work)	\$1,000,000
Applicable bonding requirements (for onsite work)	

For projects less than ONE HUNDRED THOUSAND DOLLARS (\$100,000.00), the General Contractor may agree to a "TURN-KEY" project option. Performance Bond and Payment Bond will not be required. Therefore, there will be no progressive payments. If ONE HUNDRED THOUSAND DOLLARS (\$100,000.00) and over a Payment and Performance Bonds will be required. Progressive payments will be issues as buildings are completed and turned in.

By submission of a proposal, the offeror agrees, if its proposal is accepted, to enter into a contract with AHA in the form included in the solicitation documents, to complete all work as specified or indicated in the contract documents for the contract price and within the time parameters indicated in the attached RFP. The offeror further accepts all of the terms and conditions of the Request for Proposal.

All proposals will be evaluated on eligibility criteria and factors for award stated in this proposal.

Affordable Housing Acquisition and Affiliate of The Housing Authority of the City of El Paso, Texas specifically reserves the right to reject any or all proposals, waive technicalities and to award the contract in the best interest of the Housing Authority. Price alone will not be the sole determining criteria in the selection process.

Effective immediately, all proposals delivered to 5300 E. Paisano must be received by Procurement Staff. The receptionist will notify a procurement staff member to accept your proposal. Receptionist staff cannot accept your proposal and is not responsible for mishandling your proposal.

Each offeror is responsible to ensure that they have received all amendments related to this solicitation. Contract Compliance will send amendments through e-procurement, through fax, etc. For those companies that download this solicitation through e-procurement, amendments will be posted to e-procurement. Companies that receive this solicitation in electronic format through other than e-procurement may not receive notifications.

Table of Contents

OPS 18-R-0022

Remodeling and Renovation of 300 units at Villa Alegre Apartments

PART I – THE SCHEDULE

- Section A *Solicitation, Offer and Award*
- Section B *Price Schedule*
- Section C *Scope of Work*

PART II – CONTRACT CLAUSES

- Section D *Clauses Incorporated by Reference
Mandatory Clauses and General Contract
Conditions*

PART III – DOCUMENTS, EXHIBITS AND OTHER ATTACHEMENTS

- Section E *Attachments A: Form of Contract
Attachment B: Floor Plan
Attachment C: Specifications
Form of Non-collusive Affidavit,
Certification of Equal Employment Agreement Federal
Labor Standards Certification Statement of Offeror’s
Qualifications
Certification Regarding Debarment and Suspension Disclosure
of Lobbying Activities
Davis Bacon
Form of Contract**
Payment and Performance
Bonds*

PART IV – REPRESENTATIONS AND INSTRUCTIONS

- Section F **Certifications and Representations of Offerors (5369-C)*
- Section G *Instructions to Offerors
Solicitation Provisions Incorporated by Reference*
- Section H *Evaluation Criteria*
- Section I *Travel Reimbursement Guidelines*
- Section J *Vendor Information Form*

*All documents listed as attachments must be submitted in order for your offer to be considered responsive, as well as HUD Form 5369-C (Certifications and Representations of Offerors), found in Section F

**Executed after award

SECTION A
SOLICITATION, OFFER AND AWARD

AFFORDABLE HOUSING ACQUISITION

RFP OPS 18-R-0022

Remodeling and Renovation of 300 units at Villa Alegre Apartments

SECTION A Solicitation, Offer and Award

1. Contract No. _____
2. Solicitation No. OPS 18-R-0022
3. Type of Solicitation
- Sealed Bid (IFB)
- Negotiated (RFP)
4. Date issued : September 26, 2018
5. Issued By: **AHA**
Procurement Administration Department
6. Address: **5300 E. Paisano Dr.**
El Paso, Texas 79905 – 2931

SOLICITATION

7.

NOTE: All offers are subject to all applicable terms and conditions contained in this solicitation.

8. For information call: **Ms. Eddie Rocha, Contract Specialist** Telephone No.: **(915) 849-3789**

Technical questions may be emailed to erocha@hacep.org no later than

9. October 15, 2018 by 4:00PM MST.

PART I- THE SCHEDULE				PART – II CONTRACT CLAUSES			
X	A	Solicitation Offer & Award	1 of 2	X	D	Incorporated by Reference General Contract Conditions Section 3 Clause- <u>AS APPLICABLE</u>	
X	B	Price Schedule	N/A	PART III – LIST OF DOCUMENTS, EXHIBITS, AND OTHER ATTACHMENTS			
X	C	Scope of Work		X	E	List of Attachments – Non-collusive Affidavit Certificate of Equal Employment Federal Labor Standards Certification Statement of Offeror’s Qualifications Form of Contract Payment/Performance Bond Debarment Certification Disclosure of Lobbying Activities Davis- Bacon Act- <u>AS APPLICABLE</u>	
				PART IV – REPRESENTATIONS AND INSTRUCTIONS			
		Deliveries or Performance		X	F	Certifications and Representations of Offerors	
		Contract Administration Data		X	G	Instructions, Conditions to Offerors Solicitation Provisions Incorporated by Reference	
		Special Contract		X	H	Evaluation Criteria	

In accordance with above, the undersigned agrees, if this offer is accepted within ninety (90) calendar days from the date for receipt of offers specified above, to furnish any or all items upon which prices are offered.

AFFORDABLE HOUSING ACQUISITION

RFP OPS 18-R-0022

Remodeling and Renovation of 300 units at Villa Alegre Apartments

SOLICITATION OFFER AND AWARD

(Must be completed by Offeror)

Offeror acknowledges receipt of amendment(s)

Number(s)	Date(s)
11. Name and Address of Offeror: 	12. Name and Title of Person Authorized to Sign Offer (TYPE OR PRINT)
13. Telephone No. (include area code) 	14. <input type="checkbox"/> Check if remittance address is different from Above – Enter such address in Federal ID No. _____
15. Signature: _____	Offer Date: _____

AWARD (To be completed by Authority)

16. Accepted as to items numbered: 	17. Amount:
18. Submit invoices to: Accounting and Finance Department accountspayable@hacep.org Attn: Accounts Payable Affordable Housing Acquisition 5300 E. Paisano Dr. El Paso, Texas 79905 – 2931	19. Technical Representative Name: <u>Satish Bhaskar</u> Telephone No. <u>915-849-3730</u>
20. Administered by: Procurement and Contract Compliance Department Affordable Housing Acquisition 5300 E. Paisano Dr. El Paso, Texas 79905 – 2931 (915) 849-3776	21. Payment will be made by: Accounts Payable Department Affordable Housing Acquisition 5300 E. Paisano Dr. El Paso, Texas 79905 – 2931 (915) 849-3742
22. Name of Contracting Officer (Type or Print) <u>Gerald Cichon, Chief Executive Officer</u>	23. Signature of Contracting Officer:
Award Date: _ _ _ _ _	IMPORTANT: Award will be made by formation of contract. Award notice will be generated by NAHRO e-procurement or similar manner. _____

PART I
THE SCHEDULE

SECTION B

PRICE SCHEDULE

AFFORDABLE HOUSING ACQUISITION

RFP OPS 18-R-0022

Remodeling and Renovation of 300 units at Villa Alegre Apartments

PHASE I					PHASE II				
VILLA ALEGRE UNIT LIST					VILLA ALEGRE UNIT LIST				
TENTATIVE START DATE					TENTATIVE START DATE				
12/15/2018 - 2/23/2019					2/24/2019 - 5/5/2019				
Note: Odd numbers are downstairs and even numbers are upstairs.					Note: Odd numbers are downstairs and even numbers are upstairs.				
	APT#	PLAN TYPE	BDRM.	Price per unit with all inclusive		APT#	PLAN TYPE	BDRM.	Price per unit with all inclusive
1	A07	c	1		1	G28	b	2	
2	A12	f	2		2	T02	c	1	
3	A14	f	2		3	S18	d	2	
4	C10	d	2		4	S13	a	1	
5	C12	f	2		5	A06	c	1	
6	C27	d	2		6	B16	c	1	
7	C30	d	2		7	D04	e	3	
8	D04	e	3		8	G04	b	2	
9	D06	e	3		9	G20	b	2	
10	E05	e	3		10	H20	d	2	
11	E06	e	3		11	H26	d	2	
12	F02	d	2		12	J07	c	1	
13	F10	d	2		13	R19	c	1	
14	F14	f	2		14	C18	d	2	
15	F16	f	2		15	S19	d	2	
16	F30	d	2		16	F25	a	1	
17	F31	d	2		17	F27	a	1	
18	F34	d	2		18	A10	c	1	
19	G06	b	2		19	B01	c	1	
20	G11	b	2		20	B19	c	1	
21	G13	b	2		21	F11	d	2	
22	H11	d	2		22	G01	b	2	
23	H18	d	2		23	Q02	e	3	
24	H20	d	2		24	S09	d	2	
25	H21	d	2		25	F23	d	2	
26	H22	d	2		26	H06	d	2	
27	H26	d	2		27	G27	b	2	
28	J02	c	1		28	F01	d	2	
29	J06	c	1		29	T01	c	1	
30	J16	c	1		30	A09	c	1	
31	K02	d	2		31	C22	d	2	
32	K03	d	2		32	B04	c	1	
33	L02	c	1		33	M09	c	1	
34	M12	c	1		34	S33	d	2	
35	N04	c	1		35	J03	c	1	
36	N09	c	1		36	A08	c	1	
37	N12	c	1		37	H16	d	2	
38	N13	c	1		38	S15	d	2	
39	N14	c	1		39	G09	b	2	
40	P07	e	3		40	B11	c	1	
41	P09	e	3		41	B09	c	1	
42	Q03	e	3		42	A05	c	1	
43	R04	c	1		43	M15	c	1	
44	S06	f	2		44	T11	c	1	
45	S18	d	2		45	K07	d	2	
46	S24	f	2		46	B17	c	1	
47	S35	d	2		47	S31	d	2	
48	T04	c	1		48	K08	d	2	
49	T09	a	1		49	M01	c	1	
50	U05	a	1		50	F29	d	2	
51	U09	d	2		51	J12	c	1	
52	U11	d	2		52	N11	c	1	
53	U13	a	1		53	A18	c	1	
54	U18	d	2		54	N16	c	1	
55	U20	d	2		55	G07	b	2	
56	U26	f	2		56	J05	c	1	
57	U29	d	2		57	Q06	e	3	
58	U30	d	2		58	H15	d	2	
59	U32	d	2		59	J01	c	1	
60	G26	b	2		60	L09	c	1	
	TOTAL					TOTAL			

AFFORDABLE HOUSING ACQUISITION

RFP OPS 18-R-0022

Remodeling and Renovation of 300 units at Villa Alegre Apartments

PHASE III VILLA ALEGRE UNIT LIST					PHASE IV VILLA ALEGRE UNIT LIST				
TENTATIVE START DATE 5/6/2019 - 7/15/2019					TENTATIVE START DATE 7/15/2019 - 9/23/2019				
Note: Odd numbers are downstairs and even numbers are upstairs.					Note: Odd numbers are downstairs and even numbers are upstairs.				
	APT#	PLAN TYPE	BDRM.	Price per unit with all inclusive		APT#	PLAN TYPE	BDRM.	Price per unit with all inclusive
1	B13	c	1		1	L07	c	1	
2	B14	c	1		2	H01	d	2	
3	N01	c	1		3	H19	d	2	
4	L10	c	1		4	E07	e	3	
5	L05	c	1		5	U06	f	2	
6	G03	b	2		6	D03	e	3	
7	C05	d	2		7	M10	c	1	
8	F22	d	2		8	M02	c	1	
9	G16	b	2		9	E02	e	3	
10	S29	d	2		10	M14	c	1	
11	U27	a	1		11	Q12	e	3	
12	R11	c	1		12	H10	d	2	
13	U12	d	2		13	E09	e	3	
14	M08	c	1		14	J04	c	1	
15	A15	c	1		15	T08	c	1	
16	B05	a	1		16	N10	c	1	
17	S05	a	1		17	U01	d	2	
18	P08	e	3		18	T05	c	1	
19	H05	d	2		19	C09	d	2	
20	R20	c	1		20	C03	a	1	
21	F13	a	1		21	C21	d	2	
22	P06	e	3		22	H24	d	2	
23	Q11	e	3		23	P05	e	3	
24	C15	d	2		24	U34	d	2	
25	Q07	e	3		25	S27	d	2	
26	R07	c	1		26	G23	b	2	
27	A13	a	1		27	B18	c	1	
28	C20	d	2		28	S21	d	2	
29	M11	c	1		29	M13	c	1	
30	N07	c	1		30	C01	d	2	
31	H07	d	2		31	G12	b	2	
32	R05	c	1		32	H04	d	2	
33	R08	c	1		33	N05	c	1	
34	R13	c	1		34	B20	c	1	
35	M16	c	1		35	U23	d	2	
36	A03	c	1		36	F24	d	2	
37	F17	d	2		37	C17	d	2	
38	B03	c	1		38	U21	d	2	
39	S10	d	2		39	J08	c	1	
40	C06	d	2		40	G08	b	2	
41	F20	d	2		41	T12	c	1	
42	H03	d	2		42	R09	c	1	
43	S25	a	1		43	B12	c	1	
44	A16	c	1		44	L08	c	1	
45	C02	d	2		45	C28	d	2	
46	U28	f	2		46	L06	c	1	
47	H14	d	2		47	C14	f	2	
48	R03	c	1		48	C32	d	2	
49	C11	a	1		49	U25	a	1	
50	F05	a	1		50	S08	d	2	
51	F08	d	2		51	U10	d	2	
52	H08	d	2		52	S01	d	2	
53	M03	c	1		53	F32	d	2	
54	J13	c	1		54	R01	c	1	
55	S36	d	2		55	U14	f	2	
56	H23	d	2		56	R14	c	1	
57	N06	c	1		57	S34	d	2	
58	R22	c	1		58	C25	a	1	
59	F33	d	2		59	K01	d	2	
60	U07	d	2		60	S26	f	2	
	TOTAL					TOTAL			

AFFORDABLE HOUSING ACQUISITION

RFP OPS 18-R-0022

Remodeling and Renovation of 300 units at Villa Alegre Apartments

PHASE V				
VILLA ALEGRE UNIT LIST				
TENTATIVE START DATE				
9/23/2019 - 12/2/2019				
Note: Odd numbers are downstairs and even numbers are upstairs.				
	APT#	PLAN TYPE	BDRM.	Price per unit with all inclusive
1	C26	f	2	
2	M04	c	1	
3	G15	b	2	
4	G17	b	2	
5	Q09	e	3	
6	U08	d	2	
7	T07	c	1	
8	D08	e	3	
9	G10	b	2	
10	J09	c	1	
11	E04	e	3	
12	N02	c	1	
13	C13	a	1	
14	A17	c	1	
15	C19	d	2	
16	U19	d	2	
17	U03	a	1	
18	E10	e	3	
19	A01	c	1	
20	R06	c	1	
21	B07	a	1	
22	N08	c	1	
23	A04	c	1	
24	G02	b	2	
25	C31	d	2	
26	R17	a	1	
27	C16	d	2	
28	K04	d	2	
29	G25	b	2	
30	L03	c	1	
31	F21	d	2	
32	U02	d	2	
33	S30	d	2	
34	H02	d	2	
35	G19	b	2	
36	S17	d	2	
37	S02	d	2	
38	C08	d	2	
39	S28	d	2	
40	L01	c	1	
41	F19	d	2	
42	F03	a	1	
43	K06	d	2	
44	J15	c	1	
45	H13	d	2	
46	R21	c	1	
47	M06	c	1	
48	J11	c	1	
49	M05	c	1	
50	G22	b	2	
51	C04	f	2	
52	D02	e	3	
53	C29	d	2	
54	F07	d	2	
55	H25	d	2	
56	C24	f	2	
57	D07	e	3	
58	G21	b	2	
59	S23	a	1	
60	G05	b	2	
	TOTAL			

AFFORDABLE HOUSING ACQUISITION

RFP OPS 18-R-0022

Remodeling and Renovation of 300 units at Villa Alegre Apartments

NOTE: All items noted below must be approved by HACEP before replacing

DESCRIPTION	UNIT	PRICE
<p>DECK:</p> <p>Remove HVAC and replace with new HVAC (to include unit and installation)</p>	EA	

Appliances and components / units
1. Water Heater
2. Refrigerator
3. Stove/Range
4. Dishwasher
5. Garbage Disposal
6. Kitchen Sink
7. Kitchen Faucet
8. Hood for Range
9. Bathroom Faucet
10. Bath Sink/Vanity/Mirror
11. Shower Tubs and surrounds including valve
12. Toilet
13. Front Door w/hardware
14. Interior Doors w/hardware
15. Light Fixtures
16. Base Trim replace
17. HVAC as needed

SECTION C
SCOPE OF SERVICES

SCOPE OF WORK

Villa Alegre Apartments has 300 units in need of remodeling and renovations, HACEP would like to put these renovated units back into the market. Contractor will be responsible in providing HACEP with the warranties for items from the manufacturer and/or the contractor who is doing the construction work. **AHA reserves the right to award multiple Contractors.**

The remodeling and renovation of the 300 units will be in five (5) Phases, which will be 60 units for each Phase every seventy (70) calendar days.

Each Phase of 60 Units will need to be completed, accepted and keys turned in to HACEP by the end of the 70 calendar days.

HACEP is seeking responses from a qualified, licensed and bonded contractor/contractors to provide the renovation service for the Villa Alegre Apartments for the following services:

UNIT:

1. Contractor is to identify old and non-working HVAC units. Those units are to be removed and discarded. Once contractor identifies those units that re to be removed, the contractor will request an inspection by the HACEP CPM to verify. Once approval to proceed is given, the contractor will remove and discard.
2. The purchase, supply and installation of new HVAC units on all units where old units have been removed.
3. Remove & replace existing water heater, and install new domestic 30 gal. water heater.
4. Remove & replace all windows in units, with new Low-E windows.
5. Remove & replace existing flooring with new flooring and/or carpet. Contractor will include carpets in all bedrooms and vinyl flooring on all other floor.
6. Remove & replace existing front door and install new doors with new hardware including the keyed door knob with deadbolt and peephole.
7. Install a new doorbell, including wiring for doorbell button on every unit.
8. Clean and paint all units, including all closet areas, furnace areas and water heater closet areas.
9. Remove & replace all existing interior doors with new interior doors, including new hardware, casing/molding around frame and door frame.
10. Remove & replace all existing light fixtures and install new light fixtures throughout the unit.
11. Remove & replace all existing base board.
12. Remove & replace existing blinds and install new window blinds on every window throughout the unit and vertical blinds on sliding doors.

13. Remove & replace the 30” pre-hung Storage Door. Include the purchase, installation, trim placement and paint.
14. Contractor and HACEP CPM will identify all wall areas where patching is required. Repair existing patching on walls and ceiling and match texture to original style. For pricing purpose include an area of 2 sq. ft. per unit. Actual quantity will be verified by CPM.
15. Contractor is to remove and replace all existing closets shelves. Contractor will install new shelves and seal and paint.

KITCHEN:

16. Remove existing, fabricate and install new cabinets and countertops in kitchen area to include back and side splashes in all walls.
17. Remove & replace existing refrigerator with new refrigerator. The selection of the size of the refrigerator will depend on the space available in each unit. The refrigerator cannot obstruct any cabinets or drawers in the kitchen.
BRAND: same or equal (Attachment C)
 - a. GE
 - b. Frigidaire
 - c. Whirlpool
18. Remove & replace existing stove with range with new stove. The selection of the size of the stove will depend on the space available in each unit.
BRAND: same or equal (Attachment C)
 - a. GE
 - b. Frigidaire
 - c. Whirlpool
19. Remove & replace existing dishwasher with new dishwasher.
BRAND: same or equal (Attachment C)
 - a. GE
 - b. Frigidaire
 - c. Whirlpool
 - d. Amana
20. Remove and replace existing vent hood for range with new vent hood for range.
BRAND: same or equal (Attachment C)
 - a. GE
 - b. Frigidaire
 - c. Whirlpool
 - d. Amana
21. Remove and replace existing kitchen sink with new kitchen sink.
22. Remove and replace existing garbage disposal with new garbage disposal.
23. Remove and replace existing kitchen faucet with new single handle kitchen faucet.
24. Remove and replace existing flooring with new flooring as mentioned in item 5.
25. Remove and replace existing baseboards in kitchen area.

BATHROOM:

26. Remove and replace existing toilet with new toilet.
27. Remove and replace existing shower tubs and replace with new shower tubs and surrounds including new mixer valve. Sterling (same or equal)
28. Remove and replace existing bathroom faucet and install new single handle bathroom faucet.
29. Remove and replace existing bath sink and vanity and install new bath sink and new vanity.
30. Remove and replace existing mirror, with new 24" x 36" mirror, install properly according to sink height.
31. Remove and replace existing towel bar, with new 24" tower bar.
32. Remove and replace existing toilet paper dispenser with new toilet paper dispenser.
33. Install a new curtain rod.
34. Remove and replace existing exhaust fan with new bathroom exhaust fan.
35. Remove and replace existing medicine cabinet with new medicine cabinet.

All removed materials, debris, trash and old appliances will be disposed by contractor properly, except for HVAC (to be inspected by HACEP). Outside area of the complex should be kept clean of debris or trash every day after working hours.

The vendor/contractor employees must be in their respective uniforms and have the appropriate credentials of their company while on the job site, which includes the proper signage on company vehicles as HACEP has a strict towing policy. Vendors/contractor selected under this solicitation will have their service vehicles added to the allowed vehicle lists at the community.

Engaging Residents: HACEP adheres to and enforces a strict policy regarding fraternization between HACEP Employees and residents. By accepting this proposal, we will expect the selected contractor(s) to also adhere to these rules. Furthermore, the selected contractor(s) will refrain from permitting its employees to enter into "side agreements" for repairs with HACEP residents. These practices may compromise the contractual obligations between both entities and potentially create a conflict of interest.

Contractor to provide the following at closing of the project. Final payment will be pending until the submission of these requirements:

1. Written Guarantees:
 - a. General Contractor for all work – One (1) year
 - b. Mechanical Contractor for all mechanical work – One (1) year
 - c. Plumbing Contractor for all plumbing work – One (1) year
 - d. Electrical Contractor for all electrical work – One (1) year
2. Appliances, mechanical and electrical equipment list and maintenance manual:
 - a. The Contractor will compile a complete equipment list and maintenance manual to include the following items for all equipment supplied under Plumbing,

Electrical, Air Conditioning and other special equipment specifications per apartment unit.

1. Name, Model, serial numbers and Manufacture
2. Complete parts numbers
3. A local source of supply for replacement parts along with suppliers and their contact information
4. Local service organization servicing the equipment and their contact information
5. All Tags, inspection slips, instruction packages, etc. must be removed from equipment and will be properly identified as to pieces of equipment form which they were taken

PART II
CONTRACT CLAUSES

SECTION D
MANDATORY CLAUSES

AFFORDABLE HOUSING ACQUISITIONRemodeling and Renovation of 300 units at
Villa Alegre Apartments**Federal Acquisition Regulation (FAR) FAR 2005-83/07-02-2015****Part II – Contract Clauses Section D****Clauses Incorporated by Reference As applicable:**

FAR#:	CLAUSE TITLE	DATE
52.202-1	Definitions	November 2013
52.203-3	Gratuities	April 1984
52.203-5	Covenant Against Contingent Fees	May 2014
52.203-7	Anti-Kickback Procedures	May 2014
52.209-6	Protecting the Governments Interest when Sub-contracting with Contractors Debarred, Suspended or Proposed for Debarment	October 2015
52.215-2	Audit and Records – Negotiation	October 2010
52.215-8	Order of Precedence – Uniform Contract Format	October 1997
52.215-14	Integrity of Unit Prices	October 2010
52.217-6	Option for Increased Quantity	March 1989
52.217-9	Option to Extend the Term of the Contract	March 2000
52.222-4	Contract Work Hours and Safety Standards Act – Overtime Compensation	May 2014
52.222-6	Construction Wage Rate Requirements	May 2014
52.222-18	Certification Requiring Knowledge of Child Labor for Listed End Products	February 2001
52.222-20	Contracts for Materials, Supplies, Articles and Equipment Exceeding \$15,000	May 2014
52.222-26	Equal Opportunity	September 2016
52.222-35	Equal Opportunity for Veterans	July 2014
52.222-36	Equal Opportunity for Workers With Disabilities	July 2014
52.223-2	Affirmative Procurement of Biobased Products Under Services and Construction Contracts	September 2013
52.223-6	Drug Free Work Place	May 2001
52.227-1	Authorization and Consent	December 2007

AFFORDABLE HOUSING ACQUISITIONRemodeling and Renovation of 300 units at
Villa Alegre Apartments

52.228-5	Insurance – Work on a Government Installation	January 1997
52.229-3	Federal, State and Local Taxes	February 2013
52.232-7	Payments Under Time-and-Materials and Labor-Hour Contracts	August 2012
52.232-18	Availability of Funds	April 1984
52.232-23	Assignment of Claims	May 2014
52.236-3	Site Investigation and Conditions Affecting the Work	July 1995
52.237-2	Protection of Government Buildings, Equipment and Vegetation	April 1984
52.237-3	Continuity of Services	January 1991
52.242-13	Bankruptcy	July 1995
52.243-3	Changes – Time-and-Materials or Labor-Hours	September 2000
52.243-7	Notification of Changes	January 2017
52.246-17	Warranty of Supplies of a Non-complex Nature	June 2003
52.248-1	Value Engineering	October 2010
52.249-2	Termination for Convenience of the Government (Fixed Price)	April 2012
52.249-8	Default (Fixed Price Supply & Service)	April 1984
52.249-14	Excusable Delays	April 1984
52.252-2	<p>Clauses Incorporated by Reference:</p> <p>This contract incorporates one or more clauses by reference, with the same forced effect as if they were given in full text.</p>	February 1998

AFFORDABLE HOUSING ACQUISITION

Remodeling and Renovation of 300 units at Villa Alegre Apartments

General Conditions for Construction Contracts - Public Housing Programs

U.S. Department of Housing and Urban Development
Office of Public and Indian Housing
OMB Approval No. 2577-0157 (exp. 3/31/2020)

Applicability. This form is applicable to any construction/development contract greater than \$150,000.

This form includes those clauses required by OMB's common rule on grantee procurement, implemented at HUD in 2 CFR 200, and those requirements set forth in Section 3 of the Housing and Urban Development Act of 1968 and its amendment by the Housing and Community Development Act of 1992, implemented by HUD at 24 CFR Part 135. The form is required for construction contracts awarded by Public Housing Agencies (PHAs).

The form is used by Housing Authorities in solicitations to provide necessary contract clauses. If the form were not used, HAs would be unable to enforce their contracts.

Public reporting burden for this collection of information is estimated to average 1.0 hours per response, including the time for reviewing instructions, searching existing data sources, gathering and maintaining the data needed, and completing and reviewing the collection of information. Responses to the collection of information are required to obtain a benefit or to retain a benefit.

The information requested does not lend itself to confidentiality.

HUD may not conduct or sponsor, and a person is not required to respond to a collection of information unless it displays a currently valid OMB number.

Clause		Page	Clause		Page
1	Definitions	2	Administrative Requirements		
2	Contractor's Responsibility for Work	2	25.	Contract Period	9
3	Architect's Duties, Responsibilities and Authority	2	26.	Order of Precedence	9
4	Other Contracts	3	27.	Payments	9
Construction Requirements			28.	Contract Modifications	10
5	Preconstruction Conference and Notice to Proceed	3	29.	Changes	10
6	Construction Progress Schedule	3	30.	Suspension of Work	11
7	Site Investigation and Conditions Affecting the Work	3	31.	Disputes	11
8	Differing Site Conditions	4	32.	Default	11
9	Specifications and Drawings for Construction	4	33.	Liquidated	12
10	As-Built Drawings	5	34.	Termination of Convenience	12
11	Material and Workmanship	5	35.	Assignment of Contract	12
12	Permits and Codes	5	36.	Insurance	12
13	Health, Safety, and Accident Prevention	6	37.	Subcontracts	13
14	Temporary Buildings and Transportation Materials	6	38.	Subcontracting with Small and Minority Firms, Women's Business Enterprise, and Labor Surplus Area Firms	13
15	Availability and Use of Utility Services	6	39.	Equal Employment Opportunity	13
16	Protection of Existing Vegetation, Structures, Equipment, Utilities, and Improvements	6	40.	Employment, Training, and Contracting Opportunities for Low-Income Persons, Section 3 of the Housing and Urban Development Act of 1968	13
17	Temporary Buildings and Transportation Materials	7	41.	Interest of Members of Congress	15
18	Clean Air and Water	7	42.	Interest of Members, Officers, or Employees and Former Members, Officers, or Employees	15
19	Energy Efficiency	7	43.	Limitations on Payments Made to Influence	15
20	Inspection and Acceptance of Construction	7	44.	Royalties and Patents	15
21	Use and Possession Prior to	8	45.	Examination and Retention of Contractor's Records	15
22	Warranty of Title	8	46.	Labor Standards-Davis-Bacon and Related Acts	15
23	Warranty of	8	47.	Non-Federal Prevailing Wage Rates	19
24	Prohibition Against	9	48.	Procurement of Recovered	19

AFFORDABLE HOUSING ACQUISITIONRemodeling and Renovation of 300 units at
Villa Alegre Apartments**1. Definitions**

- (a) "Architect" means the person or other entity engaged by the PHA to perform architectural, engineering, design, and other services related to the work as provided for in the contract. When a PHA uses an engineer to act in this capacity, the terms "architect" and "engineer" shall be synonymous. The Architect shall serve as a technical representative of the Contracting Officer. The Architect's authority is as set forth elsewhere in this contract.
- (b) "Contract" means the contract entered into between the PHA and the Contractor. It includes the forms of Bid, the Bid Bond, the Performance and Payment Bond or Bonds or other assurance of completion, the Certifications, Representations, and Other Statements of Bidders (form HUD-5370), these General Conditions of the Contract for Construction (form HUD-5370), the applicable wage rate determinations from the U.S. Department of Labor, any special conditions included elsewhere in the contract, the specifications, and drawings. It includes all formal changes to any of those documents by addendum, change order, or other modification.
- (c) "Contracting Officer" means the person delegated the authority by the PHA to enter into, administer, and/or terminate this contract and designated as such in writing to the Contractor. The term includes any successor Contracting Officer and any duly authorized representative of the Contracting Officer also designated in writing. The Contracting Officer shall be deemed the authorized agent of the PHA in all dealings with the Contractor.
- (d) "Contractor" means the person or other entity entering into the contract with the PHA to perform all of the work required under the contract.
- (e) "Drawings" means the drawings enumerated in the schedule of drawings contained in the Specifications and as described in the contract clause entitled Specifications and Drawings for Construction herein.
- (f) "HUD" means the United States of America acting through the Department of Housing and Urban Development including the Secretary, or any other person designated to act on its behalf. HUD has agreed, subject to the provisions of an Annual Contributions Contract (ACC), to provide financial assistance to the PHA, which includes assistance in financing the work to be performed under this contract. As defined elsewhere in these General Conditions or the contract documents, the determination of HUD may be required to authorize changes in the work or for release of funds to the PHA for payment to the Contractor. Notwithstanding HUD's role, nothing in this contract shall be construed to create any contractual relationship between the Contractor and HUD.
- (g) "Project" means the entire project, whether construction or rehabilitation, the work for which is provided for in whole or in part under this contract.
- (h) "PHA" means the Public Housing Agency organized under applicable state laws which is a party to this contract.
- (j) "Specifications" means the written description of the technical requirements for construction and includes the criteria and tests for determining whether the requirements are met.
- (l) "Work" means materials, workmanship, and manufacture and fabrication of components.

2. Contractor's Responsibility for Work

- (a) The Contractor shall furnish all necessary labor, materials, tools, equipment, and transportation necessary for performance of the work. The Contractor shall also furnish all necessary water, heat, light, and power not made available to the Contractor by the PHA pursuant to the clause entitled Availability and Use of Utility Services herein.
- (b) The Contractor shall perform on the site, and with its own organization, work equivalent to at least [] (12 percent unless otherwise indicated) of the total amount of work to be performed under the order. This percentage may be reduced by a supplemental agreement to this order if, during performing the work, the Contractor requests a reduction and the Contracting Officer determines that the reduction would be to the advantage of the PHA.
- (c) At all times during performance of this contract and until the work is completed and accepted, the Contractor shall directly superintend the work or assign and have on the work site a competent superintendent who is satisfactory to the Contracting Officer and has authority to act for the Contractor.
- (d) The Contractor shall be responsible for all damages to persons or property that occur as a result of the Contractor's fault or negligence, and shall take proper safety and health precautions to protect the work, the workers, the public, and the property of others. The Contractor shall hold and save the PHA, its officers and agents, free and harmless from liability of any nature occasioned by the Contractor's performance. The Contractor shall also be responsible for all materials delivered and work performed until completion and acceptance of the entire work, except for any completed unit of work which may have been accepted under the contract.
- (e) The Contractor shall lay out the work from base lines and bench marks indicated on the drawings and be responsible for all lines, levels, and measurements of all work executed under the contract. The Contractor shall verify the figures before laying out the work and will be held responsible for any error resulting from its failure to do so.
- (f) The Contractor shall confine all operations (including storage of materials) on PHA premises to areas authorized or approved by the Contracting Officer.
- (g) The Contractor shall at all times keep the work area, including storage areas, free from accumulations of waste materials. After completing the work and before final inspection, the Contractor shall (1) remove from the premises all scaffolding, equipment, tools, and materials (including rejected materials) that are not the property of the PHA and all rubbish caused by its work; (2) leave the work area in a clean, neat, and orderly condition satisfactory to the Contracting Officer; (3) perform all specified tests; and, (4) deliver the installation in complete and operating condition.
- (h) The Contractor's responsibility will terminate when all work has been completed, the final inspection made, and the work accepted by the Contracting Officer. The Contractor will then be released from further obligation except as required by the warranties specified elsewhere in the contract.

3. Architect's Duties, Responsibilities, and Authority

- (a) The Architect for this contract, and any successor, shall be designated in writing by the Contracting Officer.

AFFORDABLE HOUSING ACQUISITIONRemodeling and Renovation of 300 units at
Villa Alegre Apartments

- (b) The Architect shall serve as the Contracting Officer's technical representative with respect to architectural, engineering, and design matters related to the work performed under the contract. The Architect may provide direction on contract performance. Such direction shall be within the scope of the contract and may not be of a nature which: (1) institutes additional work outside the scope of the contract; (2) constitutes a change as defined in the Changes clause herein; (3) causes an increase or decrease in the cost of the contract; (4) alters the Construction Progress Schedule; or (5) changes any of the other express terms or conditions of the contract.
- (c) The Architect's duties and responsibilities may include but shall not be limited to:
- (1) Making periodic visits to the work site, and on the basis of his/her on-site inspections, issuing written reports to the PHA which shall include all observed deficiencies. The Architect shall file a copy of the report with the Contractor's designated representative at the site;
 - (2) Making modifications in drawings and technical specifications and assisting the Contracting Officer in the preparation of change orders and other contract modifications for issuance by the Contracting Officer;
 - (3) Reviewing and making recommendations with respect to - (i) the Contractor's construction progress schedules; (ii) the Contractor's shop and detailed drawings; (iii) the machinery, mechanical and other equipment and materials or other articles proposed for use by the Contractor; and, (iv) the Contractor's price breakdown and progress payment estimates; and,
 - (4) Assisting in inspections, signing Certificates of Completion, and making recommendations with respect to acceptance of work completed under the contract.

4. Other Contracts

The PHA may undertake or award other contracts for additional work at or near the site of the work under this contract. The Contractor shall fully cooperate with the other contractors and with PHA employees and shall carefully adapt scheduling and performing the work under this contract to accommodate the additional work, heeding any direction that may be provided by the Contracting Officer. The Contractor shall not commit or permit any act that will interfere with the performance of work by any other contractor or by PHA employees

Construction Requirements**5. Pre-construction Conference and Notice to Proceed**

- (a) Within ten calendar days of contract execution, and prior to the commencement of work, the Contractor shall attend a preconstruction conference with representatives of the PHA, its Architect, and other interested parties convened by the PHA. The conference will serve to acquaint the participants with the general plan of the construction operation and all other requirements of the contract. The PHA will provide the Contractor with the date, time, and place of the conference.
- (b) The contractor shall begin work upon receipt of a written Notice to Proceed from the Contracting Officer or designee. The Contractor shall not begin work prior to receiving such notice.

6. Construction Progress Schedule

- (a) The Contractor shall, within five days after the work commences on the contract or another period of time determined by the Contracting Officer, prepare and submit to the Contracting Officer for approval three copies of a practicable schedule showing the order in which the Contractor proposes to perform the work, and the dates on which the Contractor contemplates starting and completing the several salient features of the work (including acquiring labor, materials, and equipment). The schedule shall be in the form of a progress chart of suitable scale to indicate appropriately the percentage of work scheduled for completion by any given date during the period. If the Contractor fails to submit a schedule within the time prescribed, the Contracting Officer may withhold approval of progress payments or take other remedies under the contract until the Contractor submits the required schedule.
- (b) The Contractor shall enter the actual progress on the chart as required by the Contracting Officer, and immediately deliver three copies of the annotated schedule to the Contracting Officer. If the Contracting Officer determines, upon the basis of inspection conducted pursuant to the clause entitled Inspection and Acceptance of Construction, herein that the Contractor is not meeting the approved schedule, the Contractor shall take steps necessary to improve its progress, including those that may be required by the Contracting Officer, without additional cost to the PHA. In this circumstance, the Contracting Officer may require the Contractor to increase the number of shifts, overtime operations, days of work, and/or the amount of construction plant, and to submit for approval any supplementary schedule or schedules in chart form as the Contracting Officer deems necessary to demonstrate how the approved rate of progress will be regained.
- (c) Failure of the Contractor to comply with the requirements of the Contracting Officer under this clause shall be grounds for a determination by the Contracting Officer that the Contractor is not prosecuting the work with sufficient diligence to ensure completion within the time specified in the Contract. Upon making this determination, the Contracting Officer may terminate the Contractor's right to proceed with the work, or any separable part of it, in accordance with the Default clause of this contract.

7. Site Investigation and Conditions Affecting the Work

- (a) The Contractor acknowledges that it has taken steps reasonably necessary to ascertain the nature and location of the work, and that it has investigated and satisfied itself as to the general and local conditions which can affect the work or its cost, including but not limited to, (1) conditions bearing upon transportation, disposal, handling, and storage of materials; (2) the availability of labor, water, electric power, and roads; (3) uncertainties of weather, river stages, tides, or similar physical conditions at the site; (4) the conformation and conditions of the ground; and (5) the character of equipment and facilities needed preliminary to and during work performance. The Contractor also acknowledges that it has satisfied itself as to the character, quality, and quantity of surface and subsurface materials or obstacles to be encountered insofar as this information is

AFFORDABLE HOUSING ACQUISITION

reasonably ascertainable from an inspection of the site, including all exploratory work done by the PHA, as well as from the drawings and specifications made a part of this contract. Any failure of the Contractor to take the actions described and acknowledged in this paragraph will not relieve the Contractor from responsibility for estimating properly the difficulty and cost of successfully performing the work, or for proceeding to successfully perform the work without additional expense to the PHA.

- (b) The PHA assumes no responsibility for any conclusions or interpretations made by the Contractor based on the information made available by the PHA. Nor does the PHA assume responsibility for any understanding reached or representation made concerning conditions which can affect the work by any of its officers or agents before the execution of this contract, unless that understanding or representation is expressly stated in this contract.

8. Differing Site Conditions

- (a) The Contractor shall promptly, and before the conditions are disturbed, give a written notice to the Contracting Officer of (1) subsurface or latent physical conditions at the site which differ materially from those indicated in this contract, or (2) unknown physical conditions at the site(s), of an unusual nature, which differ materially from those ordinarily encountered and generally recognized as inhering in work of the character provided for in the contract.
- (b) The Contracting Officer shall investigate the site conditions promptly after receiving the notice. Work shall not proceed at the affected site, except at the Contractor's risk, until the Contracting Officer has provided written instructions to the Contractor. If the conditions do materially so differ and cause an increase or decrease in the Contractor's cost of, or the time required for, performing any part of the work under this contract, whether or not changed as a result of the conditions, the Contractor shall file a claim in writing to the PHA within ten days after receipt of such instructions and, in any event, before proceeding with the work. An equitable adjustment in the contract price, the delivery schedule, or both shall be made under this clause and the contract modified in writing accordingly.
- (c) No request by the Contractor for an equitable adjustment to the contract under this clause shall be allowed, unless the Contractor has given the written notice required; provided, that the time prescribed in (a) above for giving written notice may be extended by the Contracting Officer.
- (d) No request by the Contractor for an equitable adjustment to the contract for differing site conditions shall be allowed if made after final payment under this contract.

9. Specifications and Drawings for Construction

- (a) The Contractor shall keep on the work site a copy of the drawings and specifications and shall at all times give the Contracting Officer access thereto. Anything mentioned in the specifications and not shown on the drawings, or shown on the drawings and not mentioned in the specifications, shall be of like effect as if shown or mentioned in both. In case of difference between drawings and specifications, the specifications shall govern. In case of discrepancy in the figures, in the drawings, or in the specifications, the matter shall be

promptly submitted to the Contracting Officer, who shall promptly make a determination in writing. Any adjustment by the Contractor without such a determination shall be at its own risk and expense. The Contracting Officer shall furnish from time to time such detailed drawings and other information as considered necessary, unless otherwise provided.

- (b) Wherever in the specifications or upon the drawings the words "directed", "required", "ordered", "designated", "prescribed", or words of like import are used, it shall be understood that the "direction", "requirement", "order", "designation", or "prescription", of the Contracting Officer is intended and similarly the words "approved", "acceptable", "satisfactory", or words of like import shall mean "approved by", or "acceptable to", or "satisfactory to" the Contracting Officer, unless otherwise expressly stated.
- (c) Where "as shown" "as indicated", "as detailed", or of similar import are used, it shall be understood that the reference is made to the drawings accompanying this contract unless stated otherwise. The word "provided" as used herein shall be understood to mean "provide complete in place" that is "furnished and installed".
- (d) "Shop drawings" means drawings, submitted to the PHA by the Contractor, subcontractor, or any lower tier subcontractor, showing in detail (1) the proposed fabrication and assembly of structural elements and (2) the installation (i.e., form, fit, and attachment details) of materials of equipment. It includes drawings, diagrams, layouts, schematics, descriptive literature, illustrations, schedules, performance and test data, and similar materials furnished by the Contractor to explain in detail specific portions of the work required by the contract. The PHA may duplicate, use, and disclose in any manner and for any purpose shop drawings delivered under this contract.
- (e) If this contract requires shop drawings, the Contractor shall coordinate all such drawings, and review them for accuracy, completeness, and compliance with other contract requirements and shall indicate its approval thereon as evidence of such coordination and review. Shop drawings submitted to the Contracting Officer without evidence of the Contractor's approval may be returned for resubmission. The Contracting Officer will indicate an approval or disapproval of the shop drawings and if not approved as submitted shall indicate the PHA's reasons therefore. Any work done before such approval shall be at the Contractor's risk. Approval by the Contracting Officer shall not relieve the Contractor from responsibility for any errors or omissions in such drawings, nor from responsibility for complying with the requirements of this contract, except with respect to variations described and approved in accordance with (f) below.
- (f) If shop drawings show variations from the contract requirements, the Contractor shall describe such variations in writing, separate from the drawings, at the time of submission. If the Architect approves any such variation and the Contracting Officer concurs, the Contracting Officer shall issue an appropriate modification to the contract, except that, if the variation is minor or does not involve a change in price or in time of performance, a modification need not be issued.
- (g) It shall be the responsibility of the Contractor to make timely requests of the PHA for such large scale and full size drawings, color schemes, and other additional information, not already in his possession, which shall be

AFFORDABLE HOUSING ACQUISITION

required in the planning and production of the work. Such requests may be submitted as the need arises, but each such request shall be filed in ample time to permit appropriate action to be taken by all parties involved so as to avoid delay.

- (h) The Contractor shall submit to the Contracting Officer for approval four copies (unless otherwise indicated) of all shop drawings as called for under the various headings of these specifications. Three sets (unless otherwise indicated) of all shop drawings, will be retained by the PHA and one set will be returned to the Contractor. As required by the Contracting Officer, the Contractor, upon completing the work under this contract, shall furnish a complete set of all shop drawings as finally approved. These drawings shall show all changes and revisions made up to the time the work is completed and accepted.
- (i) This clause shall be included in all subcontracts at any tier. It shall be the responsibility of the Contractor to ensure that all shop drawings prepared by subcontractors are submitted to the Contracting Officer.

10. As-Built Drawings

- (a) "As-built drawings," as used in this clause, means drawings submitted by the Contractor or subcontractor at any tier to show the construction of a particular structure or work as actually completed under the contract. "As-built drawings" shall be synonymous with "Record drawings."
- (b) As required by the Contracting Officer, the Contractor shall provide the Contracting Officer accurate information to be used in the preparation of permanent as-built drawings. For this purpose, the Contractor shall record on one set of contract drawings all changes from the installations originally indicated, and record final locations of underground lines by depth from finish grade and by accurate horizontal offset distances to permanent surface improvements such as buildings, curbs, or edges of walks.
- (c) This clause shall be included in all subcontracts at any tier. It shall be the responsibility of the Contractor to ensure that all as-built drawings prepared by subcontractors are submitted to the Contracting Officer.

11. Material and Workmanship

- (a) All equipment, material, and articles furnished under this contract shall be new and of the most suitable grade for the purpose intended, unless otherwise specifically provided in this contract. References in the contract to equipment, material, articles, or patented processes by trade name, make, or catalog number, shall be regarded as establishing a standard of quality and shall not be construed as limiting competition. The Contractor may, at its option, use any equipment, material, article, or process that, in the judgment of, and as approved by the Contracting Officer, is equal to that named in the specifications, unless otherwise specifically provided in this contract.
- (b) Approval of equipment and materials.
- (1) The Contractor shall obtain the Contracting Officer's approval of the machinery and mechanical and other equipment to be incorporated into the work. When requesting approval, the Contractor shall furnish to the Contracting Officer the name of the manufacturer, the model number, and other information concerning the performance, capacity, nature, and rating of the

machinery and mechanical and other equipment. When required by this contract or by the Contracting Officer, the Contractor shall also obtain the Contracting Officer's approval of the material or articles which the Contractor contemplates incorporating into the work. When requesting approval, the Contractor shall provide full information concerning the material or articles. Machinery, equipment, material, and articles that do not have the required approval shall be installed or used at the risk of subsequent rejection.

- (2) When required by the specifications or the Contracting Officer, the Contractor shall submit appropriately marked samples (and certificates related to them) for approval at the Contractor's expense, with all shipping charges prepaid. The Contractor shall label, or otherwise properly mark on the container, the material or product represented, its place of origin, the name of the producer, the Contractor's name, and the identification of the construction project for which the material or product is intended to be used.
- (3) Certificates shall be submitted in triplicate, describing each sample submitted for approval and certifying that the material, equipment or accessory complies with contract requirements. The certificates shall include the name and brand of the product, name of manufacturer, and the location where produced.
- (4) Approval of a sample shall not constitute a waiver of the PHA right to demand full compliance with contract requirements. Materials, equipment and accessories may be rejected for cause even though samples have been approved.
- (5) Wherever materials are required to comply with recognized standards or specifications, such specifications shall be accepted as establishing the technical qualities and testing methods, but shall not govern the number of tests required to be made nor modify other contract requirements. The Contracting Officer may require laboratory test reports on items submitted for approval or may approve materials on the basis of data submitted in certificates with samples. Check tests will be made on materials delivered for use only as frequently as the Contracting Officer determines necessary to insure compliance of materials with the specifications. The Contractor will assume all costs of retesting materials which fail to meet contract requirements and/or testing materials offered in substitution for those found deficient.
- (6) After approval, samples will be kept in the Project office until completion of work. They may be built into the work after a substantial quantity of the materials they represent has been built in and accepted.
- (c) Requirements concerning lead-based paint. The Contractor shall comply with the requirements concerning lead-based paint contained in the Lead-Based Paint Poisoning Prevention Act (42 U.S.C. 4821-4846) as implemented by 24 CFR Part 35.

12. Permits and Codes

- (a) The Contractor shall give all notices and comply with all applicable laws, ordinances, codes, rules and regulations. Notwithstanding the requirement of the Contractor to comply with the drawings and specifications in the contract, all work installed shall comply with all applicable codes and regulations as amended by any

AFFORDABLE HOUSING ACQUISITION

waivers. Before installing the work, the Contractor shall examine the drawings and the specifications for compliance with applicable codes and regulations bearing on the work and shall immediately report any discrepancy it may discover to the Contracting Officer. Where the requirements of the drawings and specifications fail to comply with the applicable code or regulation, the Contracting Officer shall modify the contract by change order pursuant to the clause entitled Changes herein to conform to the code or regulation.

- (b) The Contractor shall secure and pay for all permits, fees, and licenses necessary for the proper execution and completion of the work. Where the PHA can arrange for the issuance of all or part of these permits, fees and licenses, without cost to the Contractor, the contract amount shall be reduced accordingly.

13. Health, Safety, and Accident Prevention

- (a) In performing this contract, the Contractor shall:

- (1) Ensure that no laborer or mechanic shall be required to work in surroundings or under working conditions which are unsanitary, hazardous, or dangerous to his/her health and/or safety as determined under construction safety and health standards promulgated by the Secretary of Labor by regulation;
- (2) Protect the lives, health, and safety of other persons;
- (3) Prevent damage to property, materials, supplies, and equipment; and,
- (4) Avoid work interruptions.

- (b) For these purposes, the Contractor shall:

- (1) Comply with regulations and standards issued by the Secretary of Labor at 29 CFR Part 1926. Failure to comply may result in imposition of sanctions pursuant to the Contract Work Hours and Safety Standards Act (Public Law 91-54, 83 Stat. 96), 40 U.S.C. 3701 et seq.; and
- (2) Include the terms of this clause in every subcontract so that such terms will be binding on each subcontractor.

- (c) The Contractor shall maintain an accurate record of exposure data on all accidents incident to work performed under this contract resulting in death, traumatic injury, occupational disease, or damage to property, materials, supplies, or equipment, and shall report this data in the manner prescribed by 29 CFR Part 1904.

- (d) The Contracting Officer shall notify the Contractor of any noncompliance with these requirements and of the corrective action required. This notice, when delivered to the Contractor or the Contractor's representative at the site of the work, shall be deemed sufficient notice of the noncompliance and corrective action required. After receiving the notice, the Contractor shall immediately take corrective action. If the Contractor fails or refuses to take corrective action promptly, the Contracting Officer may issue an order stopping all or part of the work until satisfactory corrective action has been taken. The Contractor shall not base any claim or request for equitable adjustment for additional time or money on any stop order issued under these circumstances.

- (e) The Contractor shall be responsible for its subcontractors' compliance with the provisions of this clause. The Contractor shall take such action with respect to any subcontract as the PHA, the Secretary of Housing and Urban Development, or the Secretary of Labor shall direct as a means of enforcing such provisions.

14. Temporary Heating

The Contractor shall provide and pay for temporary heating, covering, and enclosures necessary to properly protect all work and materials against damage by dampness and cold, to dry out the work, and to facilitate the completion of the work. Any permanent heating equipment used shall be turned over to the PHA in the condition and at the time required by the specifications.

15. Availability and Use of Utility Services

- (a) The PHA shall make all reasonably required amounts of utilities available to the Contractor from existing outlets and supplies, as specified in the contract. Unless otherwise provided in the contract, the amount of each utility service consumed shall be charged to or paid for by the Contractor at prevailing rates charged to the PHA or, where the utility is produced by the PHA, at reasonable rates determined by the Contracting Officer. The Contractor shall carefully conserve any utilities furnished without charge.
- (b) The Contractor, at its expense and in a manner satisfactory to the Contracting Officer, shall install and maintain all necessary temporary connections and distribution lines, and all meters required to measure the amount of each utility used for the purpose of determining charges. Before final acceptance of the work by the PHA, the Contractor shall remove all the temporary connections, distribution lines, meters, and associated paraphernalia.

16. Protection of Existing Vegetation, Structures, Equipment, Utilities, and Improvements

- (a) The Contractor shall preserve and protect all structures, equipment, and vegetation (such as trees, shrubs, and grass) on or adjacent to the work site, which are not to be removed under this contract, and which do not unreasonably interfere with the work required under this contract.
- (b) The Contractor shall only remove trees when specifically authorized to do so, and shall avoid damaging vegetation that will remain in place. If any limbs or branches of trees are broken during performance of this contract, or by the careless operation of equipment, or by workmen, the Contractor shall trim those limbs or branches with a clean cut and paint the cut with a tree-pruning compound as directed by the Contracting Officer.
- (c) The Contractor shall protect from damage all existing improvements and utilities (1) at or near the work site and (2) on adjacent property of a third party, the locations of which are made known to or should be known by the Contractor. Prior to disturbing the ground at the construction site, the Contractor shall ensure that all underground utility lines are clearly marked.
- (d) The Contractor shall shore up, brace, underpin, secure, and protect as necessary all foundations and other parts of existing structures adjacent to, adjoining, and in the vicinity of the site, which may be affected by the excavations or other operations connected with the construction of the project.
- (e) Any equipment temporarily removed as a result of work under this contract shall be protected, cleaned, and replaced in the same condition as at the time of award of this contract.

AFFORDABLE HOUSING ACQUISITION

- (f) New work which connects to existing work shall correspond in all respects with that to which it connects and/or be similar to existing work unless otherwise required by the specifications.
- (g) No structural members shall be altered or in any way weakened without the written authorization of the Contracting Officer, unless such work is clearly specified in the plans or specifications.
- (h) If the removal of the existing work exposes discolored or unfinished surfaces, or work out of alignment, such surfaces shall be refinished, or the material replaced as necessary to make the continuous work uniform and harmonious. This, however, shall not be construed to require the refinishing or reconstruction of dissimilar finishes previously exposed, or finished surfaces in good condition, but in different planes or on different levels when brought together by the removal of intervening work, unless such refinishing or reconstruction is specified in the plans or specifications.
- (i) The Contractor shall give all required notices to any adjoining or adjacent property owner or other party before the commencement of any work.
- (j) The Contractor shall indemnify and save harmless the PHA from any damages on account of settlement or the loss of lateral support of adjoining property, any damages from changes in topography affecting drainage, and from all loss or expense and all damages for which the PHA may become liable in consequence of such injury or damage to adjoining and adjacent structures and their premises.
- (k) The Contractor shall repair any damage to vegetation, structures, equipment, utilities, or improvements, including those that are the property of a third party, resulting from failure to comply with the requirements of this contract or failure to exercise reasonable care in performing the work. If the Contractor fails or refuses to repair the damage promptly, the Contracting Officer may have the necessary work performed and charge the cost to the Contractor.

17. Temporary Buildings and Transportation of Materials

- (a) Temporary buildings (e.g., storage sheds, shops, offices, sanitary facilities) and utilities may be erected by the Contractor only with the approval of the Contracting Officer and shall be built with labor and materials furnished by the Contractor without expense to the PHA. The temporary buildings and utilities shall remain the property of the Contractor and shall be removed by the Contractor at its expense upon completion of the work. With the written consent of the Contracting Officer, the buildings and utilities may be abandoned and need not be removed.
- (b) The Contractor shall, as directed by the Contracting Officer, use only established roadways, or use temporary roadways constructed by the Contractor when and as authorized by the Contracting Officer. When materials are transported in prosecuting the work, vehicles shall not be loaded beyond the loading capacity recommended by the manufacturer of the vehicle or prescribed by any federal, state, or local law or regulation. When it is necessary to cross curbs or sidewalks, the Contractor shall protect them from damage. The Contractor shall repair or pay for the repair of any damaged curbs, sidewalks, or roads.

18. Clean Air and Water

The contractor shall comply with the Clean Air Act, as amended, 42 USC 7401 et seq., the Federal Water Pollution Control Water Act, as amended, 33 U.S.C. 1251 et seq., and standards issued pursuant thereto in the facilities in which this contract is to be performed.

19. Energy Efficiency

The Contractor shall comply with mandatory standards and policies relating to energy efficiency which are contained in the energy conservation plan issued in compliance with the Energy Policy and Conservation Act (Pub.L. 94-163) for the State in which the work under the contract is performed.

20. Inspection and Acceptance of Construction

- (a) Definitions. As used in this clause -
- (1) "Acceptance" means the act of an authorized representative of the PHA by which the PHA approves and assumes ownership of the work performed under this contract. Acceptance may be partial or complete.
 - (2) "Inspection" means examining and testing the work performed under the contract (including, when appropriate, raw materials, equipment, components, and intermediate assemblies) to determine whether it conforms to contract requirements.
 - (3) "Testing" means that element of inspection that determines the properties or elements, including functional operation of materials, equipment, or their components, by the application of established scientific principles and procedures.
- (b) The Contractor shall maintain an adequate inspection system and perform such inspections as will ensure that the work performed under the contract conforms to contract requirements. All work is subject to PHA inspection and test at all places and at all reasonable times before acceptance to ensure strict compliance with the terms of the contract.
- (c) PHA inspections and tests are for the sole benefit of the PHA and do not: (1) relieve the Contractor of responsibility for providing adequate quality control measures; (2) relieve the Contractor of responsibility for loss or damage of the material before acceptance; (3) constitute or imply acceptance; or, (4) affect the continuing rights of the PHA after acceptance of the completed work under paragraph (j) below.
- (d) The presence or absence of the PHA inspector does not relieve the Contractor from any contract requirement, nor is the inspector authorized to change any term or condition of the specifications without the Contracting Officer's written authorization. All instructions and approvals with respect to the work shall be given to the Contractor by the Contracting Officer.
- (e) The Contractor shall promptly furnish, without additional charge, all facilities, labor, and material reasonably needed for performing such safe and convenient inspections and tests as may be required by the Contracting Officer. The PHA may charge to the Contractor any additional cost of inspection or test when work is not ready at the time specified by the Contractor for inspection or test, or when prior rejection makes reinspection or retest necessary. The PHA shall perform all inspections and tests in a manner that will not unnecessarily delay the work. Special, full size, and performance tests shall be performed as described in the contract.

AFFORDABLE HOUSING ACQUISITION

- (f) The PHA may conduct routine inspections of the construction site on a daily basis.
- (g) The Contractor shall, without charge, replace or correct work found by the PHA not to conform to contract requirements, unless the PHA decides that it is in its interest to accept the work with an appropriate adjustment in contract price. The Contractor shall promptly segregate and remove rejected material from the premises.
- (h) If the Contractor does not promptly replace or correct rejected work, the PHA may (1) by contract or otherwise, replace or correct the work and charge the cost to the Contractor, or (2) terminate for default the Contractor's right to proceed.
- (i) If any work requiring inspection is covered up without approval of the PHA, it must, if requested by the Contracting Officer, be uncovered at the expense of the Contractor. If at any time before final acceptance of the entire work, the PHA considers it necessary or advisable, to examine work already completed by removing or tearing it out, the Contractor, shall on request, promptly furnish all necessary facilities, labor, and material. If such work is found to be defective or nonconforming in any material respect due to the fault of the Contractor or its subcontractors, the Contractor shall defray all the expenses of the examination and of satisfactory reconstruction. If, however, such work is found to meet the requirements of the contract, the Contracting Officer shall make an equitable adjustment to cover the cost of the examination and reconstruction, including, if completion of the work was thereby delayed, an extension of time.
- (j) The Contractor shall notify the Contracting Officer, in writing, as to the date when in its opinion all or a designated portion of the work will be substantially completed and ready for inspection. If the Architect determines that the state of preparedness is as represented, the PHA will promptly arrange for the inspection. Unless otherwise specified in the contract, the PHA shall accept, as soon as practicable after completion and inspection, all work required by the contract or that portion of the work the Contracting Officer determines and designates can be accepted separately. Acceptance shall be final and conclusive except for latent defects, fraud, gross mistakes amounting to fraud, or the PHA's right under any warranty or guarantee.

21. Use and Possession Prior to Completion

- (a) The PHA shall have the right to take possession of or use any completed or partially completed part of the work. Before taking possession of or using any work, the Contracting Officer shall furnish the Contractor a list of items of work remaining to be performed or corrected on those portions of the work that the PHA intends to take possession of or use. However, failure of the Contracting Officer to list any item of work shall not relieve the Contractor of responsibility for complying with the terms of the contract. The PHA's possession or use shall not be deemed an acceptance of any work under the contract.
- (b) While the PHA has such possession or use, the Contractor shall be relieved of the responsibility for (1) the loss of or damage to the work resulting from the PHA's possession or use, notwithstanding the terms of the clause entitled Permits and Codes herein; (2) all maintenance costs on the areas occupied; and, (3) furnishing heat, light, power, and water used in the areas

occupied without proper remuneration therefore. If prior possession or use by the PHA delays the progress of the work or causes additional expense to the Contractor, an equitable adjustment shall be made in the contract price or the time of completion, and the contract shall be modified in writing accordingly.

22. Warranty of Title

The Contractor warrants good title to all materials, supplies, and equipment incorporated in the work and agrees to deliver the premises together with all improvements thereon free from any claims, liens or charges, and agrees further that neither it nor any other person, firm or corporation shall have any right to a lien upon the premises or anything appurtenant thereto.

23. Warranty of Construction

- (a) In addition to any other warranties in this contract, the Contractor warrants, except as provided in paragraph (j) of this clause, that work performed under this contract conforms to the contract requirements and is free of any defect in equipment, material, or workmanship performed by the Contractor or any subcontractor or supplier at any tier. This warranty shall continue for a period of _____ (one year unless otherwise indicated) from the date of final acceptance of the work. If the PHA takes possession of any part of the work before final acceptance, this warranty shall continue for a period of (one year unless otherwise indicated) from the date that the PHA takes possession.
- (b) The Contractor shall remedy, at the Contractor's expense, any failure to conform, or any defect. In addition, the Contractor shall remedy, at the Contractor's expense, any damage to PHA-owned or controlled real or personal property when the damage is the result of—
- (1) The Contractor's failure to conform to contract requirements; or
 - (2) Any defects of equipment, material, workmanship or design furnished by the Contractor.
- (c) The Contractor shall restore any work damaged in fulfilling the terms and conditions of this clause. The Contractor's warranty with respect to work repaired or replaced will run for (one year unless otherwise indicated) from the date of repair or replacement.
- (d) The Contracting Officer shall notify the Contractor, in writing, within a reasonable time after the discovery of any failure, defect or damage.
- (e) If the Contractor fails to remedy any failure, defect, or damage within a reasonable time after receipt of notice, the PHA shall have the right to replace, repair or otherwise remedy the failure, defect, or damage at the Contractor's expense.
- (f) With respect to all warranties, express or implied, from subcontractors, manufacturers, or suppliers for work performed and materials furnished under this contract, the Contractor shall:
- (1) Obtain all warranties that would be given in normal commercial practice;
 - (2) Require all warranties to be executed in writing, for the benefit of the PHA; and,
 - (3) Enforce all warranties for the benefit of the PHA.
- (g) In the event the Contractor's warranty under paragraph (a) of this clause has expired, the PHA may bring suit at its own expense to enforce a subcontractor's, manufacturer's or supplier's warranty.

AFFORDABLE HOUSING ACQUISITION

Remodeling and Renovation of 300 units at Villa Alegre Apartments

- (h) Unless a defect is caused by the negligence of the Contractor or subcontractor or supplier at any tier, the Contractor shall not be liable for the repair of any defect of material or design furnished by the PHA nor for the repair of any damage that results from any defect in PHA furnished material or design.
- (i) Notwithstanding any provisions herein to the contrary, the establishment of the time periods in paragraphs (a) and (c) above relate only to the specific obligation of the Contractor to correct the work, and have no relationship to the time within which its obligation to comply with the contract may be sought to be enforced, nor to the time within which proceedings may be commenced to establish the Contractor's liability with respect to its obligation other than specifically to correct the work.
- (j) This warranty shall not limit the PHA's rights under the Inspection and Acceptance of Construction clause of this contract with respect to latent defects, gross mistakes or fraud.

24. Prohibition Against Liens

The Contractor is prohibited from placing a lien on the PHA's property. This prohibition shall apply to all subcontractors at any tier and all materials suppliers.

Administrative Requirements

25. Contract Period

this contract within _____ calendar days of the effective date of the contract, or within the time schedule established in the notice to proceed issued by the Contracting Officer.

26. Order of Provisions

In the event of a conflict between these General Conditions and the Specifications, the General Conditions shall prevail. In the event of a conflict between the contract and any applicable state or local law or regulation, the state or local law or regulation shall prevail; provided that such state or local law or regulation does not conflict with, or is less restrictive than applicable federal law, regulation, or Executive Order. In the event of such a conflict, applicable federal law, regulation, and Executive Order shall prevail.

27. Payments

- (a) The PHA shall pay the Contractor the price as provided in this contract.
- (b) The PHA shall make progress payments approximately every 30 days as the work proceeds, on estimates of work accomplished which meets the standards of quality established under the contract, as approved by the Contracting Officer. The PHA may, subject to written determination and approval of the Contracting Officer, make more frequent payments to contractors which are qualified small businesses.
- (c) Before the first progress payment under this contract, the Contractor shall furnish, in such detail as requested by the Contracting Officer, a breakdown of the total contract price showing the amount included therein for each principal category of the work, which shall substantiate the payment amount requested in order to provide a

basis for determining progress payments. The breakdown shall be approved by the Contracting Officer and must be acceptable to HUD. If the contract covers more than one project, the Contractor shall furnish a separate breakdown for each. The values and quantities employed in making up this breakdown are for determining the amount of progress payments and shall not be construed as a basis for additions to or deductions from the contract price. The Contractor shall prorate its overhead and profit over the construction period of the contract.

- (d) The Contractor shall submit, on forms provided by the PHA, periodic estimates showing the value of the work performed during each period based upon the approved submitted not later than _____ days in advance of the date set for payment and are subject to correction and revision as required. The estimates must be approved by the Contracting Officer with the concurrence of the Architect prior to payment. If the contract covers more than one project, the Contractor shall furnish a separate progress payment estimate for each.
- (e) Along with each request for progress payments and the required estimates, the Contractor shall furnish the following certification, or payment shall not be made: I hereby certify, to the best of my knowledge and belief, that:
 - (1) The amounts requested are only for performance in accordance with the specifications, terms, and conditions of the contract;
 - (2) Payments to subcontractors and suppliers have been made from previous payments received under the contract, and timely payments will be made from the proceeds of the payment covered by this certification, in accordance with subcontract agreements; and,
 - (3) This request for progress payments does not include any amounts which the prime contractor intends to withhold or retain from a subcontractor or supplier in accordance with the terms and conditions of the subcontract.

Name:

Title:

Date:

- (f) Except as otherwise provided in State law, the PHA shall retain ten (10) percent of the amount of progress payments until completion and acceptance of all work under the contract; except, that if upon completion of 50 percent of the work, the Contracting Officer, after consulting with the Architect, determines that the Contractor's performance and progress are satisfactory, the PHA may make the remaining payments in full for the work subsequently completed. If the Contracting Officer subsequently determines that the Contractor's performance and progress are unsatisfactory, the PHA shall reinstate the ten (10) percent (or other percentage as provided in State law) retainage until such time as the Contracting Officer determines that performance and progress are satisfactory.
- (g) The Contracting Officer may authorize material delivered on the site and preparatory work done to be taken into consideration when computing progress payments.

AFFORDABLE HOUSING ACQUISITIONRemodeling and Renovation of 300 units at
Villa Alegre Apartments

Material delivered to the Contractor at locations other than the site may also be taken into consideration if the Contractor furnishes satisfactory evidence that (1) it has acquired title to such material; (2) the material is properly stored in a bonded warehouse, storage yard, or similar suitable place as may be approved by the Contracting Officer; (3) the material is insured to cover its full value; and (4) the material will be used to perform this contract. Before any progress payment which includes delivered material is made, the Contractor shall furnish such documentation as the Contracting Officer may require to assure the protection of the PHA's interest in such materials. The Contractor shall remain responsible for such stored material notwithstanding the transfer of title to the PHA.

- (h) All material and work covered by progress payments made shall, at the time of payment become the sole property of the PHA, but this shall not be construed as (1) relieving the Contractor from the sole responsibility for all material and work upon which payments have been made or the restoration of any damaged work; or, (2) waiving the right of the PHA to require the fulfillment of all of the terms of the contract. In the event the work of the Contractor has been damaged by other contractors or persons other than employees of the PHA in the course of their employment, the Contractor shall restore such damaged work without cost to the PHA and to seek redress for its damage only from those who directly caused it.
- (i) The PHA shall make the final payment due the Contractor under this contract after (1) completion and final acceptance of all work; and (2) presentation of release of all claims against the PHA arising by virtue of this contract, other than claims, in stated amounts, that the Contractor has specifically excepted from the operation of the release. Each such exception shall embrace no more than one claim, the basis and scope of which shall be clearly defined. The amounts for such excepted claims shall not be included in the request for final payment. A release may also be required of the assignee if the Contractor's claim to amounts payable under this contract has been assigned.
- (j) Prior to making any payment, the Contracting Officer may require the Contractor to furnish receipts or other evidence of payment from all persons performing work and supplying material to the Contractor, if the Contracting Officer determines such evidence is necessary to substantiate claimed costs.
- (k) The PHA shall not; (1) determine or adjust any claims for payment or disputes arising there under between the Contractor and its subcontractors or material suppliers; or, (2) withhold any moneys for the protection of the subcontractors or material suppliers. The failure or refusal of the PHA to withhold moneys from the Contractor shall in nowise impair the obligations of any surety or sureties under any bonds furnished under this contract.

28. Contract Modifications

- (a) Only the Contracting Officer has authority to modify any term or condition of this contract. Any contract modification shall be authorized in writing.
- (b) The Contracting Officer may modify the contract unilaterally (1) pursuant to a specific authorization stated in a contract clause (e.g., Changes); or (2) for administrative matters which do not change the rights or

responsibilities of the parties (e.g., change in the PHA address). All other contract modifications shall be in the form of supplemental agreements signed by the Contractor and the Contracting Officer.

- (c) When a proposed modification requires the approval of HUD prior to its issuance (e.g., a change order that exceeds the PHA's approved threshold), such modification shall not be effective until the required approval is received by the PHA.

29. Changes

- (a) The Contracting Officer may, at any time, without notice to the sureties, by written order designated or indicated to be a change order, make changes in the work within the general scope of the contract including changes:
 - (1) In the specifications (including drawings and designs);
 - (2) In the method or manner of performance of the work;
 - (3) PHA-furnished facilities, equipment, materials, services, or site; or,
 - (4) Directing the acceleration in the performance of the work.
- (b) Any other written order or oral order (which, as used in this paragraph (b), includes direction, instruction, interpretation, or determination) from the Contracting Officer that causes a change shall be treated as a change order under this clause; provided, that the Contractor gives the Contracting Officer written notice stating (1) the date, circumstances and source of the order and (2) that the Contractor regards the order as a change order.
- (c) Except as provided in this clause, no order, statement or conduct of the Contracting Officer shall be treated as a change under this clause or entitle the Contractor to an equitable adjustment.
- (d) If any change under this clause causes an increase or decrease in the Contractor's cost of, or the time required for the performance of any part of the work under this contract, whether or not changed by any such order, the Contracting Officer shall make an equitable adjustment and modify the contract in writing. However, except for an adjustment based on defective specifications, no proposal for any change under paragraph (b) above shall be allowed for any costs incurred more than 20 days (5 days for oral orders) before the Contractor gives written notice as required. In the case of defective specifications for which the PHA is responsible, the equitable adjustment shall include any increased cost reasonably incurred by the Contractor in attempting to comply with the defective specifications.
- (e) The Contractor must assert its right to an adjustment under this clause within 30 days after (1) receipt of a written change order under paragraph (a) of this clause, or (2) the furnishing of a written notice under paragraph (b) of this clause, by submitting a written statement describing the general nature and the amount of the proposal. If the facts justify it, the Contracting Officer may extend the period for submission. The proposal may be included in the notice required under paragraph (b) above. No proposal by the Contractor for an equitable adjustment shall be allowed if asserted after final payment under this contract.
- (f) The Contractor's written proposal for equitable adjustment shall be submitted in the form of a lump sum proposal supported with an itemized breakdown of all increases and decreases in the contract in at least the following details:

AFFORDABLE HOUSING ACQUISITION

- (1) Direct Costs. Materials (list individual items, the quantity and unit cost of each, and the aggregate cost); Transportation and delivery costs associated with materials; Labor breakdowns by hours or unit costs (identified with specific work to be performed); Construction equipment exclusively necessary for the change; Costs of preparation and/ or revision to shop drawings resulting from the change; Worker's Compensation and Public Liability Insurance; Employment taxes under FICA and FUTA; and, Bond Costs when size of change warrants revision.
- (2) Indirect Costs. Indirect costs may include overhead, general and administrative expenses, and fringe benefits not normally treated as direct costs.
- (3) Profit. The amount of profit shall be negotiated and may vary according to the nature, extent, and complexity of the work required by the change. The allowability of the direct and indirect costs shall be determined in accordance with the Contract Cost Principles and Procedures for Commercial Firms in Part 31 of the Federal Acquisition Regulation (48 CFR 1-31), as implemented by HUD Handbook 2210.18, in effect on the date of this contract. The Contractor shall not be allowed a profit on the profit received by any subcontractor. Equitable adjustments for deleted work shall include a credit for profit and may include a credit for indirect costs. On proposals covering both increases and decreases in the amount of the contract, the application of indirect costs and profit shall be on the net-change in direct costs for the Contractor or subcontractor performing the work.
- (g) The Contractor shall include in the proposal its request for time extension (if any), and shall include sufficient information and dates to demonstrate whether and to what extent the change will delay the completion of the contract in its entirety.
- (h) The Contracting Officer shall act on proposals within 30 days after their receipt, or notify the Contractor of the date when such action will be taken.
- (i) Failure to reach an agreement on any proposal shall be a dispute under the clause entitled Disputes herein. Nothing in this clause, however, shall excuse the Contractor from proceeding with the contract as changed.
- (j) Except in an emergency endangering life or property, no change shall be made by the Contractor without a prior order from the Contracting Officer.

30. Suspension of Work

- (a) The Contracting Officer may order the Contractor in writing to suspend, delay, or interrupt all or any part of the work of this contract for the period of time that the Contracting Officer determines appropriate for the convenience of the PHA.
- (b) If the performance of all or any part of the work is, for an unreasonable period of time, suspended, delayed, or interrupted (1) by an act of the Contracting Officer in the administration of this contract, or (2) by the Contracting Officer's failure to act within the time specified (or within a reasonable time if not specified) in this contract an adjustment shall be made for any increase in the cost of performance of the contract (excluding profit) necessarily caused by such unreasonable suspension, delay, or interruption and the contract modified in writing accordingly. However, no adjustment shall be made under this clause for any suspension, delay, or interruption to the extent that performance would have

been so suspended, delayed, or interrupted by any other cause, including the fault or negligence of the Contractor or for which any equitable adjustment is provided for or excluded under any other provision of this contract.

- (c) A claim under this clause shall not be allowed (1) for any costs incurred more than 20 days before the Contractor shall have notified the Contracting Officer in writing of the act or failure to act involved (but this requirement shall not apply as to a claim resulting from a suspension order); and, (2) unless the claim, in an amount stated, is asserted in writing as soon as practicable after the termination of the suspension, delay, or interruption, but not later than the date of final payment under the contract.

31. Disputes

- (a) "Claim," as used in this clause, means a written demand or written assertion by one of the contracting parties seeking, as a matter of right, the payment of money in a sum certain, the adjustment or interpretation of contract terms, or other relief arising under or relating to the contract. A claim arising under the contract, unlike a claim relating to the contract, is a claim that can be resolved under a contract clause that provides for the relief sought by the claimant. A voucher, invoice, or other routine request for payment that is not in dispute when submitted is not a claim. The submission may be converted to a claim by complying with the requirements of this clause, if it is disputed either as to liability or amount or is not acted upon in a reasonable time.
- (b) Except for disputes arising under the clauses entitled Labor Standards - Davis Bacon and Related Acts, herein, all disputes arising under or relating to this contract, including any claims for damages for the alleged breach thereof which are not disposed of by agreement, shall be resolved under this clause.
- (c) All claims by the Contractor shall be made in writing and submitted to the Contracting Officer for a written decision. A claim by the PHA against the Contractor shall be subject to a written decision by the Contracting Officer.
- (d) The Contracting Officer shall, within 60 (unless otherwise indicated) days after receipt of the request, decide the claim or notify the Contractor of the date by which the decision will be made.
- (e) The Contracting Officer's decision shall be final unless the Contractor (1) appeals in writing to a higher level in the PHA in accordance with the PHA's policy and procedures, (2) refers the appeal to an independent mediator or arbitrator, or (3) files suit in a court of competent jurisdiction. Such appeal must be made within (30 unless otherwise indicated) days after receipt of the Contracting Officer's decision.
- (f) The Contractor shall proceed diligently with performance of this contract, pending final resolution of any request for relief, claim, appeal, or action arising under or relating to the contract, and comply with any decision of the Contracting Officer.

32. Default

- (a) If the Contractor refuses or fails to prosecute the work, or any separable part thereof, with the diligence that will insure its completion within the time specified in this contract, or any extension thereof, or fails to complete said work within this time, the Contracting Officer may, by written notice to the Contractor, terminate the right to

AFFORDABLE HOUSING ACQUISITIONRemodeling and Renovation of 300 units at
Villa Alegre Apartments

- proceed with the work (or separable part of the work) that has been delayed. In this event, the PHA may take over the work and complete it, by contract or otherwise, and may take possession of and use any materials, equipment, and plant on the work site necessary for completing the work. The Contractor and its sureties shall be liable for any damage to the PHA resulting from the Contractor's refusal or failure to complete the work within the specified time, whether or not the Contractor's right to proceed with the work is terminated. This liability includes any increased costs incurred by the PHA in completing the work.
- (b) The Contractor's right to proceed shall not be terminated or the Contractor charged with damages under this clause if—
- (1) The delay in completing the work arises from unforeseeable causes beyond the control and without the fault or negligence of the Contractor. Examples of such causes include (i) acts of God, or of the public enemy, (ii) acts of the PHA or other governmental entity in either its sovereign or contractual capacity, (iii) acts of another contractor in the performance of a contract with the PHA, (iv) fires, (v) floods, (vi) epidemics, (vii) quarantine restrictions, (viii) strikes, (ix) freight embargoes, (x) unusually severe weather, or (xi) delays of subcontractors or suppliers at any tier arising from unforeseeable causes beyond the control and without the fault or negligence of both the Contractor and the subcontractors or suppliers; and
- (2) The Contractor, within days (10 days unless otherwise indicated) from the beginning of such delay (unless extended by the Contracting Officer) notifies the Contracting Officer in writing of the causes of delay. The Contracting Officer shall ascertain the facts and the extent of the delay. If, in the judgment of the Contracting Officer, the findings of fact warrant such action, time for completing the work shall be extended by written modification to the contract. The findings of the Contracting Officer shall be reduced to a written decision which shall be subject to the provisions of the Disputes clause of this contract.
- (c) If, after termination of the Contractor's right to proceed, it is determined that the Contractor was not in default, or that the delay was excusable, the rights and obligations of the parties will be the same as if the termination had been for convenience of the PHA.

33. Liquidated Damages

- (a) If the Contractor fails to complete the work within the time specified in the contract, or any extension, as specified in the clause entitled Default of this contract, the Contractor shall pay to the PHA as liquidated damages, the sum of \$ _____ [Contracting Officer insert amount] for each day of delay. If different completion dates are specified in the contract for separate parts or stages of the work, the amount of liquidated damages shall be assessed on those parts or stages which are delayed. To the extent that the Contractor's delay or nonperformance is excused under another clause in this contract, liquidated damages shall not be due the PHA. The Contractor remains liable for damages caused other than by delay.
- (b) If the PHA terminates the Contractor's right to proceed, the resulting damage will consist of liquidated damages until such reasonable time as may be required for final

- completion of the work together with any increased costs occasioned the PHA in completing the work.
- (c) If the PHA does not terminate the Contractor's right to proceed, the resulting damage will consist of liquidated damages until the work is completed or accepted.

34. Termination for Convenience

- (a) The Contracting Officer may terminate this contract in whole, or in part, whenever the Contracting Officer determines that such termination is in the best interest of the PHA. Any such termination shall be effected by delivery to the Contractor of a Notice of Termination specifying the extent to which the performance of the work under the contract is terminated, and the date upon which such termination becomes effective.
- (b) If the performance of the work is terminated, either in whole or in part, the PHA shall be liable to the Contractor for reasonable and proper costs resulting from such termination upon the receipt by the PHA of a properly presented claim setting out in detail: (1) the total cost of the work performed to date of termination less the total amount of contract payments made to the Contractor; (2) the cost (including reasonable profit) of settling and paying claims under subcontracts and material orders for work performed and materials and supplies delivered to the site, payment for which has not been made by the PHA to the Contractor or by the Contractor to the subcontractor or supplier; (3) the cost of preserving and protecting the work already performed until the PHA or assignee takes possession thereof or assumes responsibility therefore; (4) the actual or estimated cost of legal and accounting services reasonably necessary to prepare and present the termination claim to the PHA; and (5) an amount constituting a reasonable profit on the value of the work performed by the Contractor.
- (c) The Contracting Officer will act on the Contractor's claim within days (60 days unless otherwise indicated) of receipt of the Contractor's claim.
- (d) Any disputes with regard to this clause are expressly made subject to the provisions of the Disputes clause of this contract.

35. Assignment of Contract

The Contractor shall not assign or transfer any interest in this contract; except that claims for monies due or to become due from the PHA under the contract may be assigned to a bank, trust company, or other financial institution. Such assignments of claims shall only be made with the written concurrence of the Contracting Officer. If the Contractor is a partnership, this contract shall inure to the benefit of the surviving or remaining member(s) of such partnership as approved by the Contracting Officer.

36. Insurance

- (a) Before commencing work, the Contractor and each subcontractor shall furnish the PHA with certificates of insurance showing the following insurance is in force and will insure all operations under the Contract:
- (1) Workers' Compensation, in accordance with state or Territorial Workers' Compensation laws.
- (2) Commercial General Liability with a combined single limit for bodily injury and property damage of not less than \$ _____ [Contracting Officer insert amount]

AFFORDABLE HOUSING ACQUISITION

per occurrence to protect the Contractor and each subcontractor against claims for bodily injury or death and damage to the property of others. This shall cover the use of all equipment, hoists, and vehicles on the site(s) not covered by Automobile Liability under (3) below. If the Contractor has a "claims made" policy, then the following additional requirements apply: the policy must provide a "retroactive date" which must be on or before the execution date of the Contract; and the extended reporting period may not be less than five years following the completion date of the Contract.

- (3) Automobile Liability on owned and non-owned motor vehicles used on the site(s) or in connection therewith for a combined single limit for bodily injury and property damage of not less than \$ _____ [Contracting Officer insert amount] per occurrence.
- (b) Before commencing work, the Contractor shall furnish the PHA with a certificate of insurance evidencing that Builder's Risk (fire and extended coverage) Insurance on all work in place and/or materials stored at the building site(s), including foundations and building equipment, is in force. The Builder's Risk Insurance shall be for the benefit of the Contractor and the PHA as their interests may appear and each shall be named in the policy or policies as an insured. The Contractor in installing equipment supplied by the PHA shall carry insurance on such equipment from the time the Contractor takes possession thereof until the Contract work is accepted by the PHA. The Builder's Risk Insurance need not be carried on excavations, piers, footings, or foundations until such time as work on the superstructure is started. It need not be carried on landscape work. Policies shall furnish coverage at all times for the full cash value of all completed construction, as well as materials in place and/or stored at the site(s), whether or not partial payment has been made by the PHA. The Contractor may terminate this insurance on buildings as of the date taken over for occupancy by the PHA. The Contractor is not required to carry Builder's Risk Insurance for modernization work which does not involve structural alterations or additions and where the PHA's existing fire and extended coverage policy can be endorsed to include such work.
- (c) All insurance shall be carried with companies which are financially responsible and admitted to do business in the State in which the project is located. If any such insurance is due to expire during the construction period, the Contractor (including subcontractors, as applicable) shall not permit the coverage to lapse and shall furnish evidence of coverage to the Contracting Officer. All certificates of insurance, as evidence of coverage, shall provide that no coverage may be canceled or non-renewed by the insurance company until at least 30 days prior written notice has been given to the Contracting Officer.

37. Subcontracts

- (a) Definitions. As used in this contract -
- (1) "Subcontract" means any contract, purchase order, or other purchase agreement, including modifications and change orders to the foregoing, entered into by a subcontractor to furnish supplies, materials, equipment, and services for the performance of the prime contract or a subcontract.

(2) "Subcontractor" means any supplier, vendor, or firm that furnishes supplies, materials, equipment, or services to or for the Contractor or another subcontractor.

- (b) The Contractor shall not enter into any subcontract with any subcontractor who has been temporarily denied participation in a HUD program or who has been suspended or debarred from participating in contracting programs by any agency of the United States Government or of the state in which the work under this contract is to be performed.
- (c) The Contractor shall be as fully responsible for the acts or omissions of its subcontractors, and of persons either directly or indirectly employed by them as for the acts or omissions of persons directly employed by the Contractor.
- (d) The Contractor shall insert appropriate clauses in all subcontracts to bind subcontractors to the terms and conditions of this contract insofar as they are applicable to the work of subcontractors.
- (e) Nothing contained in this contract shall create any contractual relationship between any subcontractor and the PHA or between the subcontractor and HUD.

38. Subcontracting with Small and Minority Firms, Women's Business Enterprise, and Labor Surplus Area Firms

The Contractor shall take the following steps to ensure that, whenever possible, subcontracts are awarded to small business firms, minority firms, women's business enterprises, and labor surplus area firms:

- (a) Placing qualified small and minority businesses and women's business enterprises on solicitation lists;
- (b) Ensuring that small and minority businesses and women's business enterprises are solicited whenever they are potential sources;
- (c) Dividing total requirements, when economically feasible, into smaller tasks or quantities to permit maximum participation by small and minority businesses and women's business enterprises;
- (d) Establishing delivery schedules, where the requirements of the contract permit, which encourage participation by small and minority businesses and women's business enterprises; and
- (e) Using the services and assistance of the U.S. Small Business Administration, the Minority Business Development Agency of the U.S. Department of Commerce, and State and local governmental small business agencies.

39. Equal Employment Opportunity

During the performance of this contract, the Contractor agrees as follows:

- (a) The Contractor shall not discriminate against any employee or applicant for employment because of race, color, religion, sex, national origin, or handicap.
- (b) The Contractor shall take affirmative action to ensure that applicants are employed, and that employees are treated during employment without regard to their race, color, religion, sex, national origin, or handicap. Such action shall include, but not be limited to, (1) employment, (2) upgrading, (3) demotion, (4) transfer, (5) recruitment or recruitment advertising, (6) layoff or termination, (7) rates of pay or other forms of compensation, and (8) selection for training, including apprenticeship.

AFFORDABLE HOUSING ACQUISITION

- (c) The Contractor shall post in conspicuous places available to employees and applicants for employment the notices to be provided by the Contracting Officer that explain this clause.
- (d) The Contractor shall, in all solicitations or advertisements for employees placed by or on behalf of the Contractor, state that all qualified applicants will receive consideration for employment without regard to race, color, religion, sex, national origin, or handicap.
- (e) The Contractor shall send, to each labor union or representative of workers with which it has a collective bargaining agreement or other contract or understanding, the notice to be provided by the Contracting Officer advising the labor union or workers' representative of the Contractor's commitments under this clause, and post copies of the notice in conspicuous places available to employees and applicants for employment.
- (f) The Contractor shall comply with Executive Order 11246, as amended, and the rules, regulations, and orders of the Secretary of Labor.
- (g) The Contractor shall furnish all information and reports required by Executive Order 11246, as amended, Section 503 of the Rehabilitation Act of 1973, as amended, and by rules, regulations, and orders of the Secretary of Labor, or pursuant thereto. The Contractor shall permit access to its books, records, and accounts by the Secretary of Labor for purposes of investigation to ascertain compliance with such rules, regulations, and orders.
- (h) In the event of a determination that the Contractor is not in compliance with this clause or any rule, regulation, or order of the Secretary of Labor, this contract may be canceled, terminated, or suspended in whole or in part, and the Contractor may be declared ineligible for further Government contracts, or Federally assisted construction contracts under the procedures authorized in Executive Order 11246, as amended. In addition, sanctions may be imposed and remedies invoked against the Contractor as provided in Executive Order 11246, as amended, the rules, regulations, and orders of the Secretary of Labor, or as otherwise provided by law.
- (i) The Contractor shall include the terms and conditions of this clause in every subcontract or purchase order unless exempted by the rules, regulations, or orders of the Secretary of Labor issued under Executive Order 11246, as amended, so that these terms and conditions will be binding upon each subcontractor or vendor. The Contractor shall take such action with respect to any subcontract or purchase order as the Secretary of Housing and Urban Development or the Secretary of Labor may direct as a means of enforcing such provisions, including sanctions for noncompliance; provided that if the Contractor becomes involved in, or is threatened with, litigation with a subcontractor or vendor as a result of such direction, the Contractor may request the United States to enter into the litigation to protect the interests of the United States.
- (j) Compliance with the requirements of this clause shall be to the maximum extent consistent with, but not in derogation of, compliance with section 7(b) of the Indian Self-Determination and Education Assistance Act and the Indian Preference clause of this contract.
- 40. Employment, Training, and Contracting Opportunities for Low-Income Persons, Section 3 of the Housing and Urban Development Act of 1968.**
- (a) The work to be performed under this contract is subject to the requirements of section 3 of the Housing and Urban Development Act of 1968, as amended, 12 U.S.C. 1701u (section 3). The purpose of section 3 is to ensure that employment and other economic opportunities generated by HUD assistance or HUD-assisted projects covered by section 3, shall, to the greatest extent feasible, be directed to low- and very low-income persons, particularly persons who are recipients of HUD assistance for housing.
- (b) The parties to this contract agree to comply with HUD's regulations in 24 CFR Part 135, which implement section 3. As evidenced by their execution of this contract, the parties to this contract certify that they are under no contractual or other impediment that would prevent them from complying with the Part 135 regulations.
- (c) The contractor agrees to send to each labor organization or representative of workers with which the contractor has a collective bargaining agreement or other understanding, if any, a notice advising the labor organization or workers' representative of the contractor's commitments under this section 3 clause, and will post copies of the notice in conspicuous places at the work site where both employees and applicants for training and employment positions can see the notice. The notice shall describe the section 3 preference, shall set forth minimum number and job titles subject to hire, availability of apprenticeship and training positions, the qualifications for each; and the name and location of the person(s) taking applications for each of the positions; and the anticipated date the work shall begin.
- (d) The contractor agrees to include this section 3 clause in every subcontract subject to compliance with regulations in 24 CFR Part 135, and agrees to take appropriate action, as provided in an applicable provision of the subcontract or in this section 3 clause, upon a finding that the subcontractor is in violation of the regulations in 24 CFR Part 135. The contractor will not subcontract with any subcontractor where the contractor has notice or knowledge that the subcontractor has been found in violation of the regulations in 24 CFR Part 135.
- (e) The contractor will certify that any vacant employment positions, including training positions, that are filled (1) after the contractor is selected but before the contract is executed, and (2) with persons other than those to whom the regulations of 24 CFR Part 135 require employment opportunities to be directed, were not filled to circumvent the contractor's obligations under 24 CFR Part 135.
- (f) Noncompliance with HUD's regulations in 24 CFR Part 135 may result in sanctions, termination of this contract for default, and debarment or suspension from future HUD assisted contracts.
- (g) With respect to work performed in connection with section 3 covered Indian housing assistance, section 7(b) of the Indian Self-Determination and Education Assistance Act (25 U.S.C. 450e) also applies to the work to be performed under this contract. Section 7(b) requires that to the greatest extent feasible (i) preference and opportunities for training and employment shall be given to Indians, and (ii) preference in the award of contracts and subcontracts shall be given to Indian organizations and Indian-owned Economic Enterprises. Parties to this contract that are subject to the provisions of section 3 and section 7(b) agree to comply with section 3 to the maximum extent feasible, but not in derogation of compliance with section 7(b).

AFFORDABLE HOUSING ACQUISITION**41. Interest of Members of Congress**

No member of or delegate to the Congress of the United States of America shall be admitted to any share or part of this contract or to any benefit that may arise therefrom.

42. Interest of Members, Officers, or Employees and Former Members, Officers, or Employees

No member, officer, or employee of the PHA, no member of the governing body of the locality in which the project is situated, no member of the governing body of the locality in which the PHA was activated, and no other public official of such locality or localities who exercises any functions or responsibilities with respect to the project, shall, during his or her tenure, or for one year thereafter, have any interest, direct or indirect, in this contract or the proceeds thereof.

43. Limitations on Payments made to Influence Certain Federal Financial Transactions

- (a) The Contractor agrees to comply with Section 1352 of Title 31, United States Code which prohibits the use of Federal appropriated funds to pay any person for influencing or attempting to influence an officer or employee of any agency, a Member of Congress, and officer or employee of Congress, or an employee of a Member of Congress in connection with any of the following covered Federal actions: the awarding of any Federal contract; the making of any Federal grant; the making of any Federal loan; the entering into of any cooperative agreement; or the modification of any Federal contract, grant, loan, or cooperative agreement.
- (b) The Contractor further agrees to comply with the requirement of the Act to furnish a disclosure (OMB Standard Form LLL, Disclosure of Lobbying Activities) if any funds other than Federal appropriated funds (including profit or fee received under a covered Federal transaction) have been paid, or will be paid, to any person for influencing or attempting to influence an officer or employee of any agency, a Member of Congress, an officer or employee of Congress, or an employee of a Member of Congress in connection with a Federal contract, grant, loan, or cooperative agreement.

44. Royalties and Patents

The Contractor shall pay all royalties and license fees. It shall defend all suits or claims for infringement of any patent rights and shall save the PHA harmless from loss on account thereof, except that the PHA shall be responsible for all such loss when a particular design, process or the product of a particular manufacturer or manufacturers is specified and the Contractor has no reason to believe that the specified design, process, or product is an infringement. If, however, the Contractor has reason to believe that any design, process or product specified is an infringement of a patent, the Contractor shall promptly notify the Contracting Officer. Failure to give such notice shall make the Contractor responsible for resultant loss.

45. Examination and Retention of Contractor's Records

- (a) The PHA, HUD, or Comptroller General of the United States, or any of their duly authorized representatives shall, until 3 years after final payment under this contract, have access to and the right to examine any of the Contractor's directly pertinent books, documents, papers, or other records involving transactions related to this contract for the purpose of making audit, examination, excerpts, and transcriptions.
- (b) The Contractor agrees to include in first-tier subcontracts under this contract a clause substantially the same as paragraph (a) above. "Subcontract," as used in this clause, excludes purchase orders not exceeding \$10,000.
- (c) The periods of access and examination in paragraphs (a) and (b) above for records relating to (1) appeals under the Disputes clause of this contract, (2) litigation or settlement of claims arising from the performance of this contract, or (3) costs and expenses of this contract to which the PHA, HUD, or Comptroller General or any of their duly authorized representatives has taken exception shall continue until disposition of such appeals, litigation, claims, or exceptions.

46. Labor Standards - Davis-Bacon and Related Acts

If the total amount of this contract exceeds \$2,000, the Federal labor standards set forth in the clause below shall apply to the development or construction work to be performed under the contract.

- (a) Minimum Wages.
- (1) All laborers and mechanics employed under this contract in the development or construction of the project(s) involved will be paid unconditionally and not less often than once a week, and without subsequent deduction or rebate on any account (except such payroll deductions as are permitted by regulations issued by the Secretary of Labor under the Copeland Act (29 CFR Part 3)), the full amount of wages and bona fide fringe benefits (or cash equivalents thereof) due at time of payment computed at rates not less than those contained in the wage determination of the Secretary of Labor which is attached hereto and made a part hereof, regardless of any contractual relationship which may be alleged to exist between the Contractor and such laborers and mechanics. Contributions made or costs reasonably anticipated for bona fide fringe benefits under Section 1(b)(2) of the Davis-Bacon Act on behalf of laborers or mechanics are considered wages paid to such laborers or mechanics, subject to the provisions of 29 CFR 5.5(a)(1)(iv); also, regular contributions made or costs incurred for more than a weekly period (but not less often than quarterly) under plans, funds, or programs which cover the regular weekly period, are deemed to be constructively made or incurred during such weekly period. Such laborers and mechanics shall be paid the appropriate wage rate and fringe benefits in the wage determination for the classification of work actually performed, without regard to skill, except as provided in 29 CFR 5.5(a)(4). Laborers or mechanics performing work in more than one classification may be compensated at the rate specified for each classification for the time actually worked therein; provided, that the employer's payroll records accurately set forth the time spent in each classification in which work is performed. The wage determination (including any additional classification and wage rates conformed under 29 CFR 5.5(a)(1)(ii) and the Davis-Bacon poster (WH-1321) shall

AFFORDABLE HOUSING ACQUISITION

be posted at all times by the Contractor and its subcontractors at the site of the work in a prominent and accessible place where it can be easily seen by the workers.

- (2) (i) Any class of laborers or mechanics, including helpers, which is not listed in the wage determination and which is to be employed under the contract shall be classified in conformance with the wage determination. HUD shall approve an additional classification and wage rate and fringe benefits therefor only when all the following criteria have been met: (A) The work to be performed by the classification requested is not performed by a classification in the wage determination; and (B) The classification is utilized in the area by the construction industry; and (C) The proposed wage rate, including any bona fide fringe benefits, bears a reasonable relationship to the wage rates contained in the wage determination.
- (ii) If the Contractor and the laborers and mechanics to be employed in the classification (if known), or their representatives, and HUD or its designee agree on the classification and wage rate (including the amount designated for fringe benefits where appropriate), a report of the action taken shall be sent by HUD or its designee to the Administrator of the Wage and Hour Division, Employee Standards Administration, U.S. Department of Labor, Washington, DC 20210. The Administrator, or an authorized representative, will approve, modify, or disapprove every additional classification action within 30 days of receipt and so advise HUD or its designee or will notify HUD or its designee within the 30-day period that additional time is necessary.
- (iii) In the event the Contractor, the laborers or mechanics to be employed in the classification or their representatives, and HUD or its designee do not agree on the proposed classification and wage rate (including the amount designated for fringe benefits, where appropriate), HUD or its designee shall refer the questions, including the views of all interested parties and the recommendation of HUD or its designee, to the Administrator of the Wage and Hour Division for determination. The Administrator, or an authorized representative, will issue a determination within 30 days of receipt and so advise HUD or its designee or will notify HUD or its designee within the 30-day period that additional time is necessary.
- (iv) The wage rate (including fringe benefits where appropriate) determined pursuant to subparagraphs (a)(2)(ii) or (iii) of this clause shall be paid to all workers performing work in the classification under this contract from the first day on which work is performed in classification.
- (3) Whenever the minimum wage rate prescribed in the contract for a class of laborers or mechanics includes a fringe benefit which is not expressed as an hourly rate, the Contractor shall either pay the benefit as stated in the wage determination or shall pay another bona fide fringe benefit or an hourly cash equivalent thereof.
- (4) If the Contractor does not make payments to a trustee or other third person, the Contractor may consider as part of the wages of any laborer or mechanic the

amount of any costs reasonably anticipated in providing bona fide fringe benefits under a plan or program; provided, that the Secretary of Labor has found, upon the written request of the Contractor, that the applicable standards of the Davis-Bacon Act have been met. The Secretary of Labor may require the Contractor to set aside in a separate account assets for the meeting of obligations under the plan or program.

- (b) Withholding of funds. HUD or its designee shall, upon its own action or upon written request of an authorized representative of the Department of Labor, withhold or cause to be withheld from the Contractor under this contract or any other Federal contract with the same prime Contractor, or any other Federally-assisted contract subject to Davis-Bacon prevailing wage requirements, which is held by the same prime Contractor, so much of the accrued payments or advances as may be considered necessary to pay laborers and mechanics, including apprentices, trainees, and helpers, employed by the Contractor or any subcontractor the full amount of wages required by the contract. In the event of failure to pay any laborer or mechanic, including any apprentice, trainee, or helper, employed or working in the construction or development of the project, all or part of the wages required by the contract, HUD or its designee may, after written notice to the Contractor, take such action as may be necessary to cause the suspension of any further payment, advance, or guarantee of funds until such violations have ceased. HUD or its designee may, after written notice to the Contractor, disburse such amounts withheld for and on account of the Contractor or subcontractor to the respective employees to whom they are due.
- (c) Payrolls and basic records.
- (1) Payrolls and basic records relating thereto shall be maintained by the Contractor during the course of the work and preserved for a period of three years thereafter for all laborers and mechanics working in the construction or development of the project. Such records shall contain the name, address, and social security number of each such worker, his or her correct classification, hourly rates of wages paid (including rates of contributions or costs anticipated for bona fide fringe benefits or cash equivalents thereof of the types described in section 1(b)(2)(B) of the Davis-Bacon Act), daily and weekly number of hours worked, deductions made, and actual wages paid. Whenever the Secretary of Labor has found, under 29 CFR 5.5(a)(1)(iv), that the wages of any laborer or mechanic include the amount of costs reasonably anticipated in providing benefits under a plan or program described in section 1(b)(2)(B) of the Davis-Bacon Act, the Contractor shall maintain records which show that the commitment to provide such benefits is enforceable, that the plan or program is financially responsible, and that the plan or program has been communicated in writing to the laborers or mechanics affected, and records which show the costs anticipated or the actual cost incurred in providing such benefits. Contractors employing apprentices or trainees under approved programs shall maintain written evidence of the registration of apprenticeship programs and certification of trainee programs, the registration of the apprentices and trainees, and the ratios and wage rates prescribed in the applicable programs.

AFFORDABLE HOUSING ACQUISITIONRemodeling and Renovation of 300 units at
Villa Alegre Apartments

- (2) (i) The Contractor shall submit weekly for each week in which any contract work is performed a copy of all payrolls to the Contracting Officer for transmission to HUD or its designee. The payrolls submitted shall set out accurately and completely all of the information required to be maintained under subparagraph (c)(1) of this clause. This information may be submitted in any form desired. Optional Form WH-347 (Federal Stock Number 029-005-00014-1) is available for this purpose and may be purchased from the Superintendent of Documents, U.S. Government Printing Office, Washington, D.C. 20402. The Contractor is responsible for the submission of copies of payrolls by all subcontractors. (Approved by the Office of Management and Budget under OMB Control Number 1214-0149.)
- (ii) Each payroll submitted shall be accompanied by a "Statement of Compliance," signed by the Contractor or subcontractor or his or her agent who pays or supervises the payment of the persons employed under the contract and shall certify the following:
- (A) That the payroll for the payroll period contains the information required to be maintained under paragraph (c) (1) of this clause and that such information is correct and complete;
- (B) That each laborer or mechanic (including each helper, apprentice, and trainee) employed on the contract during the payroll period has been paid the full weekly wages earned, without rebate, either directly or indirectly, and that no deductions have been made either directly or indirectly from the full wages earned, other than permissible deductions as set forth in 29 CFR Part 3; and
- (C) That each laborer or mechanic has been paid not less than the applicable wage rates and fringe benefits or cash equivalents for the classification of work performed, as specified in the applicable wage determination incorporated into the contract.
- (iii) The weekly submission of a properly executed certification set forth on the reverse side of Optional Form WH-347 shall satisfy the requirements for submission of the "Statement of Compliance" required by subparagraph (c)(2)(ii) of this clause.
- (iv) The falsification of any of the above certifications may subject the Contractor or subcontractor to civil or criminal prosecution under Section 1001 of Title 18 and Section 3729 of Title 31 of the United States Code.
- (3) The Contractor or subcontractor shall make the records required under subparagraph (c)(1) available for inspection, copying, or transcription by authorized representatives of HUD or its designee, the Contracting Officer, or the Department of Labor and shall permit such representatives to interview employees during working hours on the job. If the Contractor or subcontractor fails to submit the required records or to make them available, HUD or its designee may, after written notice to the Contractor, take such action as may be necessary to cause the suspension of any further payment, advance, or guarantee of funds. Furthermore, failure to submit the required records upon request or to make such records available may be grounds for debarment action pursuant to 29 CFR 5.12.
- (d) (1) Apprentices. Apprentices will be permitted to work at less than the predetermined rate for the work they performed when they are employed pursuant to and individually registered in a bona fide apprenticeship program registered with the U.S. Department of Labor, Employment and Training Administration, Office of Apprenticeship and Training, Employer and Labor Services (OATELS), or with a State Apprenticeship Agency recognized by OATELS, or if a person is employed in his or her first 90 days of probationary employment as an apprentice in such an apprenticeship program, who is not individually registered in the program, but who has been certified by OATELS or a State Apprenticeship Agency (where appropriate) to be eligible for probationary employment as an apprentice. The allowable ratio of apprentices to journeymen on the job site in any craft classification shall not be greater than the ratio permitted to the Contractor as to the entire work force under the registered program. Any worker listed on a payroll at an apprentice wage rate, who is not registered or otherwise employed as stated in this paragraph, shall be paid not less than the applicable wage rate on the wage determination for the classification of work actually performed. In addition, any apprentice performing work on the job site in excess of the ratio permitted under the registered program shall be paid not less than the applicable wage rate on the wage determination for the work actually performed. Where a contractor is performing construction on a project in a locality other than that in which its program is registered, the ratios and wage rates (expressed in percentages of the journeyman's hourly rate) specified in the Contractor's or subcontractor's registered program shall be observed. Every apprentice must be paid at not less than the rate specified in the registered program for the apprentice's level of progress, expressed as a percentage of the journeyman hourly rate specified in the applicable wage determination. Apprentices shall be paid fringe benefits in accordance with the provisions of the apprenticeship program. If the apprenticeship program does not specify fringe benefits, apprentices must be paid the full amount of fringe benefits listed on the wage determination for the applicable classification. If the Administrator of the Wage and Hour Division determines that a different practice prevails for the applicable apprentice classification, fringes shall be paid in accordance with that determination. In the event OATELS, or a State Apprenticeship Agency recognized by OATELS, withdraws approval of an apprenticeship program, the Contractor will no longer be permitted to utilize apprentices at less than the applicable predetermined rate for the work performed until an acceptable program is approved.
- (2) Trainees. Except as provided in 29 CFR 5.16, trainees will not be permitted to work at less than the predetermined rate for the work performed unless they are employed pursuant to and individually registered in a program which has received prior approval, evidenced by formal certification by the U.S. Department of Labor, Employment and Training Administration. The ratio of trainees to journeymen on the job site shall not be greater than permitted under

AFFORDABLE HOUSING ACQUISITION

- the plan approved by the Employment and Training Administration. Every trainee must be paid at not less than the rate specified in the approved program for the trainee's level of progress, expressed as a percentage of the journeyman hourly rate specified in the applicable wage determination. Trainees shall be paid fringe benefits in accordance with the provisions of the trainee program. If the trainee program does not mention fringe benefits, trainees shall be paid the full amount of fringe benefits listed in the wage determination unless the Administrator of the Wage and Hour Division determines that there is an apprenticeship program associated with the corresponding journeyman wage rate in the wage determination which provides for less than full fringe benefits for apprentices. Any employee listed on the payroll at a trainee rate who is not registered and participating in a training plan approved by the Employment and Training Administration shall be paid not less than the applicable wage rate in the wage determination for the classification of work actually performed. In addition, any trainee performing work on the job site in excess of the ratio permitted under the registered program shall be paid not less than the applicable wage rate in the wage determination for the work actually performed. In the event the Employment and Training Administration withdraws approval of a training program, the Contractor will no longer be permitted to utilize trainees at less than the applicable predetermined rate for the work performed until an acceptable program is approved.
- (3) Equal employment opportunity. The utilization of apprentices, trainees, and journeymen under this clause shall be in conformity with the equal employment opportunity requirements of Executive Order 11246, as amended, and 29 CFR Part 30.
- (e) Compliance with Copeland Act requirements. The Contractor shall comply with the requirements of 29 CFR Part 3, which are hereby incorporated by reference in this contract.
- (f) Contract termination; debarment. A breach of this contract clause may be grounds for termination of the contract and for debarment as a Contractor and a subcontractor as provided in 29 CFR 5.12.
- (g) Compliance with Davis-Bacon and related Act requirements. All rulings and interpretations of the Davis-Bacon and related Acts contained in 29 CFR Parts 1, 3, and 5 are herein incorporated by reference in this contract.
- (h) Disputes concerning labor standards. Disputes arising out of the labor standards provisions of this clause shall not be subject to the general disputes clause of this contract. Such disputes shall be resolved in accordance with the procedures of the Department of Labor set forth in 29 CFR Parts 5, 6, and 7. Disputes within the meaning of this clause include disputes between the Contractor (or any of its subcontractors) and the PHA, HUD, the U.S. Department of Labor, or the employees or their representatives.
- (i) Certification of eligibility.
- (1) By entering into this contract, the Contractor certifies that neither it (nor he or she) nor any person or firm who has an interest in the Contractor's firm is a person or firm ineligible to be awarded contracts by the United States Government by virtue of section 3(a) of the Davis-Bacon Act or 29 CFR 5.12(a)(1).
- (2) No part of this contract shall be subcontracted to any person or firm ineligible for award of a United States Government contract by virtue of section 3(a) of the Davis-Bacon Act or 29 CFR 5.12(a)(1).
- (3) The penalty for making false statements is prescribed in the U. S. Criminal Code, 18 U.S.C. 1001.
- (j) Contract Work Hours and Safety Standards Act. As used in this paragraph, the terms "laborers" and "mechanics" include watchmen and guards.
- (1) Overtime requirements. No contractor or subcontractor contracting for any part of the contract work which may require or involve the employment of laborers or mechanics, including watchmen and guards, shall require or permit any such laborer or mechanic in any workweek in which the individual is employed on such work to work in excess of 40 hours in such workweek unless such laborer or mechanic receives compensation at a rate not less than one and one-half times the basic rate of pay for all hours worked in excess of 40 hours in such workweek.
- (2) Violation; liability for unpaid wages; liquidated damages. In the event of any violation of the provisions set forth in subparagraph (j)(1) of this clause, the Contractor and any subcontractor responsible therefor shall be liable for the unpaid wages. In addition, such Contractor and subcontractor shall be liable to the United States (in the case of work done under contract for the District of Columbia or a territory, to such District or to such territory), for liquidated damages. Such liquidated damages shall be computed with respect to each individual laborer or mechanic (including watchmen and guards) employed in violation of the provisions set forth in subparagraph (j)(1) of this clause, in the sum of \$10 for each calendar day on which such individual was required or permitted to work in excess of the standard workweek of 40 hours without payment of the overtime wages required by provisions set forth in subparagraph (j)(1) of this clause.
- (3) Withholding for unpaid wages and liquidated damages. HUD or its designee shall upon its own action or upon written request of an authorized representative of the Department of Labor withhold or cause to be withheld, from any moneys payable on account of work performed by the Contractor or subcontractor under any such contract or any Federal contract with the same prime Contractor, or any other Federally-assisted contract subject to the Contract Work Hours and Safety Standards Act, which is held by the same prime Contractor, such sums as may be determined to be necessary to satisfy any liabilities of such Contractor or subcontractor for unpaid wages and liquidated damages as provided in the provisions set forth in subparagraph (j)(2) of this clause.
- (k) Subcontracts. The Contractor or subcontractor shall insert in any subcontracts all the provisions contained in this clause, and such other clauses as HUD or its designee may by appropriate instructions require, and also a clause requiring the subcontractors to include these provisions in any lower tier subcontracts. The prime Contractor shall be responsible for the compliance by any subcontractor or lower tier subcontractor with all these provisions.

AFFORDABLE HOUSING ACQUISITION

47. Non-Federal Prevailing Wage Rates

- (a) Any prevailing wage rate (including basic hourly rate and any fringe benefits), determined under State or tribal law to be prevailing, with respect to any employee in any trade or position employed under the contract, is inapplicable to the contract and shall not be enforced against the Contractor or any subcontractor, with respect to employees engaged under the contract whenever such non-Federal prevailing wage rate exceeds:
 - (1) The applicable wage rate determined by the Secretary of Labor pursuant to the Davis-Bacon Act (40 U.S.C. 3141 et seq.) to be prevailing in the locality with respect to such trade;
- (b) An applicable apprentice wage rate based thereon specified in an apprenticeship program registered with the U.S. Department of Labor (DOL) or a DOL-recognized State Apprenticeship Agency; or
- (c) An applicable trainee wage rate based thereon specified in a DOL-certified trainee program.

48. Procurement of Recovered Materials.

- (a) In accordance with Section 6002 of the Solid Waste Disposal Act, as amended by the Resource Conservation and Recovery Act, the Contractor shall procure items designated in guidelines of the Environmental Protection Agency (EPA) at 40 CFR Part 247 that contain the highest percentage of recovered materials practicable, consistent with maintaining a satisfactory level of competition. The Contractor shall procure items designated in the EPA guidelines that contain the highest percentage of recovered materials practicable unless the Contractor determines that such items: (1) are not reasonably available in a reasonable period of time; (2) fail to meet reasonable performance standards, which shall be determined on the basis of the guidelines of the National Institute of Standards and Technology, if applicable to the item; or (3) are only available at an unreasonable price.
- (b) Paragraph (a) of this clause shall apply to items purchased under this contract where: (1) the Contractor purchases in excess of \$10,000 of the item under this contract; or (2) during the preceding Federal fiscal year, the Contractor: (i) purchased any amount of the items for use under a contract that was funded with Federal appropriations and was with a Federal agency or a State agency or agency of a political subdivision of a State; and (ii) purchased a total of in excess of \$10,000 of the item both under and outside that contract.

AFFORDABLE HOUSING ACQUISITION**SECTION 3 SPECIFICATIONS CLAUSE** (revised 1/22/16 –Compliance Coord,)

The Section 3 information contained in the following pages is to be inserted in its entirety into every solicitation for work or contracts by Housing Authority of the City of El Paso (HACEP), the contractor and sub-contractors. All required forms and the Section 3 Clause are already included along with instructions to all contractors bidding work.

All contractors requiring any sub-contractors **MUST** issue this package and receive these completed **required Section 3 forms** before issuing any contracts:

- Section 3 Business Certification (if applicable)
- Section 3 Action Plan
- Section 3 Self-Certification and Skills Data Form (For Section 3 residents and New hires when applicable)

If the contractor is claiming certification as a 51% Resident Owned Business (ROB) or is certifying as a 30% employer the following form must be returned for all employees that meet the low- or Very low-income requirement

- Section 3 Self-Certification and Skills Data Form

Overview and Instructions for Contractors

HACEP's Section 3 policy requires that when the **Section 3 regulation is triggered by a need for new hires (whether individual employees, contractors or sub-contractors)**, every effort within the contractor's disposal must be made to the greatest extent feasible to offer all available employment and contracting opportunities to its residents based on the tiers below. Only when the regulation is triggered by a contractor and they are unable to offer employment or contracting. The contractor may offer employment related training to the Section 3 residents.

I. Tiers for offering all opportunities to Section 3 Residents and Resident Owned Businesses

1. At the site where the work is being performed
2. At any other HACEP owned or managed property
3. Other HUD funded beneficiaries including Section 8 Voucher holders
4. Other low-income people in the HACEP service area

II. What is a Section 3 Business Concern and how do they receive Preference in contract award?

A business that meets these certification definitions must receive Preference in contracting:

1. Is 51% or more owned by Section 3 residents;
 2. Employs Section 3 residents for at least 30% of its full-time, permanent staff; or **(During the entire life of the contract)**
 3. Provides evidence of a commitment to subcontract to Section 3 business concerns, 25% or more of the dollar amount of the awarded contract.
- YOU MUST MAINTAIN THOSE PREFERENCE LEVELS DURING THE ENTIRE CONTRACT OR RISK HAVING THE CONTRACT TERMINATED FOR FAILURE TO COMPLY

III. Other Methods of Compliance

Contractors can provide an array of trainings to Section 3 residents that are employment related, skills enhancing or employment readiness in nature. Here are the methods of achieving compliance through training. Training and other employment opportunities must receive prior approval from HACEP.

1. Contractor must develop a solid professional curriculum and it must be pre-approved by HACEP.

AFFORDABLE HOUSING ACQUISITION

2. Contractor may identify a person or persons that are qualified to provide the training within their staff.
3. Contractors can partner with other groups that provide the desired training and pay them directly for the service.
4. The contractor can sub-contract the Section 3 compliance training to an outside firm specializing in training and educational programs to Section 3 residents.

IV. All Contracts and All Contractors must meet Section 3 compliance by:

Step 1 Give notice of any and all opportunities for employment and contracting to HACEP residents and other low and very low-income area residents and businesses by posting the position (s) in community sources that are generally available to low income residents and the general-public.

- (1) Local community newspapers
- (2) Widely distributed newspapers
- (3) Company agency website
- (4) HACEP communities and HACEP website
- (5) Upper Rio Grande Workforce Solutions
- (6) Other locations as approved by HACEP

Step 2 Hiring notices should clearly state the requirements for applying and achieving the opportunity and that the position is a “Section 3” covered position under the HUD Act of 1968.

Step 3 Utilize the Section 3 Clause in RFB’s, RFP’, RFQ’s, etc., contracts and subcontracts.

Step 4 Hold informational meetings when possible prior to requesting bids or taking applications so the residents or businesses are encouraged to apply for the employment or contracting.

Step 5 Provide preference in hiring and contracting to Section 3 applicants and contractors when all factors are equal for the opportunity, including price and salary requests.

AFFORDABLE HOUSING ACQUISITION

Remodeling and Renovation of 300 units at
Villa Alegre Apartments

Section 3 Clause

Training and Employment Opportunities for Residents in the Project Area (Section 3, HUD Act of 1968; 24 CFR 135)

(a) The work to be performed under this contract is subject to the requirements of section 3 of the Housing and Urban Development Act of 1968, as amended, 12 U.S.C. 1701u (section 3). The purpose of section 3 is to ensure that employment and other economic opportunities generated by HUD assistance or HUD-assisted projects covered by section 3, shall, to the greatest extent feasible, be directed to low- and very low-income persons, particularly persons who are recipients of HUD assistance for housing.

(b) The parties to this contract agree to comply with HUD's regulations in 24 CFR Part 135, which implement section 3. As evidenced by their execution of this contract, the parties to this contract certify that they are under no contractual or other impediment that would prevent them from complying with the Part 135 regulations.

(c) The contractor agrees to send to each labor organization or representative of workers with which the contractor has a collective bargaining agreement or other understanding, if any, a notice advising the labor organization or workers' representative of the contractor's commitments under this section 3 clause, and will post copies of the notice in conspicuous places at the work site where both employees and applicants for training and employment positions can see the notice. The notice shall describe the section 3 preference, shall set forth minimum number and job titles subject to hire, availability of Section 3 apprenticeship and training positions, the qualifications for each; and the name and location of the person(s) taking applications for each of the positions; and the anticipated date the work shall begin.

(d) The contractor agrees to include this section 3 clause in every subcontract subject to compliance with regulations in 24 CFR Part 135, and agrees to take appropriate action, as provided in an applicable provision of the subcontract or in this section 3 clause, upon a finding that the subcontractor is in violation of the regulations in 24 CFR Part 135. The contractor will not subcontract with any subcontractor where the contractor has notice or knowledge that the subcontractor has been found in violation of the regulations in 24 CFR Part 135.

(e) The contractor will certify that any vacant employment positions, including training positions, that are filled (1) after the contractor is selected but before the contract is executed, and (2) with persons other than those to whom the regulations of 24 CFR Part 135 require employment opportunities to be directed, were not filled to circumvent the contractor's obligations under 24 CFR Part 135.

(f) Noncompliance with HUD's regulations in 24 CFR Part 135 may result in sanctions, termination of this contract for default, and debarment or suspension from future HUD assisted contracts.

AFFORDABLE HOUSING ACQUISITION

Public Housing Authority Required Submittal Section 3 Certification and Action Plan

Name of Business _____

Address of Business _____

Type of Business (Check One): Corporation Partnership Sole Proprietorship Other

Contract/Solicitation Name or Number: _____

All firms and individuals intending to do business with RECIPIENT and contractors MUST complete and submit this Action Plan and submit it with the bid, offer, or proposal. **Any solicitation response that does not include this document (completed and signed) will be considered non-responsive and not eligible for award.**

I am Certifying as a Section 3 Concern and requesting Preference accordingly (Select only One Option):

51% Resident Owned
 A business claiming status as a Section 3 Resident-Owned Business Concern (ROB) entity:
 Initial here to select this option _____
 Provide Certification for Section 3 Residents and proof that they own a minimum 51% of the

IMPROTANT NOTICE: Preference must be maintained for the entire contract or the contract will be in non-compliance and at risk of termination.

30% Employer of Section 3 Residents Currently or New Hires
 Section 3 status, because at least 30% of the existing or newly hired workforce for this specific contract will be Section 3 residents throughout the entire contract period. If a Prime or General Contractor is electing this option, the 30% employment requirement will be for the entire project including all the sub-contractors employees.
 Initial here to select this option _____
 I anticipate my total number of employees for this contract to be ____ and ____ will be qualified Section 3.
 Check all methods you will employ to secure Section 3 Residents/Persons. Posting the position in community sources that are generally available to low income residents and the general public is a standard requirement. Check at least three (3) methods you will employ

- The local community newspaper
- Widely distributed newspaper
- Company or agency website
- HACEP communities and HACEP website
- Upper Rio Grande Workforce Solutions

25% Sub-Contracting
 A business claiming Section 3 status by subcontracting 25% of the dollar award to qualified Section 3 Business:
 Initial here to select this option _____

IF CONTRACTOR DOES NOT ANTICIPATE TRIGGERING THE REGULATION, CHECK BOTH BOXES.

I do not anticipate any new employees on this contract.

I do not anticipate any new contracting on this contract.

AFFORDABLE HOUSING ACQUISITION

PRIOR COMPLIANCE CERTIFICATION

I am certifying that I have complied with the HUD Section 3 Regulations in my past contracts **when required** by the recipient, contractor by employing the following:

1. I was a Section 3 Resident-Owned Business (ROB). List the Contracts and HUD Funded Entity and Contact:

2. I complied with Section 3 by employing at least 30% of my workforce. List the Contracts and HUD Funded Entity and Contact:

3. I complied with Section 3 by subcontracting 25% of the total dollar award to a qualified Section 3 Business. List the Contracts and HUD Funded Entity and Contact:

4. I complied with Section 3 on a previous HUD funded contract by doing these things and with these entities: Describe:

5. I completed HUD Section 3 covered contracts in the past three years but was not required to meet compliance.

Check the box of the corresponding reason below.

I did not trigger the regulation by hiring any new employees on my Previous contract(s) in violation of the Section 3 regulation.

I did not trigger the regulation by hiring any contractors on previous, contract(s) in violation of the Section 3 regulation.

6. I certify that I have not performed previous Section 3 covered contracts

Signature

Print Name

Date

AFFORDABLE HOUSING ACQUISITION

Remodeling and Renovation of 300 units at Villa Alegre Apartments

SECTION 3 SELF-CERTIFICATION AND SKILLS DATA FORM

Certification for Section 3 Residents or other Low-Income Persons Seeking Employment, Training or Contracting

Eligibility for Preference

A Section 3 resident seeking the preference in training and employment provided by this part shall certify, or submit evidence to the recipient contractor or subcontractor, if requested, that the person is a Section 3 resident, as defined in Section 135.5. (An example of evidence of eligibility for the preference is evidence of receipt of public assistance, or evidence of participation in a public assistance program).

I, _____, am legal resident of the United States and meet the income eligibility and federal guidelines for a Section 3 Resident as defined on the next page.

My home address is:

_____ Must be a **Street** address not a P O Box # Apt Number

_____ City State Zip Home # Cell #

I have attached the following documentation as evidence of my status:

____ Copy of lease ____ Copy of recipient of public assistance
____ Copy of Evidence of Participation ____ other evidence: _____
In a public assistance program

Graduated High School or GED (month/year) _____ I Read and Speak English Fluently Yes or No

Attended College, Trade, or Technical School ____ Yes/No Graduated ____ Yes/No Year Graduated _____

Check the Skills, Trades, and/or Professions you have been employed in or contracted to do for others:

<input type="checkbox"/> Drywall Hanging	<input type="checkbox"/> Drywall Finishing	<input type="checkbox"/> Interior Painting	<input type="checkbox"/> Framing
<input type="checkbox"/> HVAC	<input type="checkbox"/> Electrical	<input type="checkbox"/> Interior Plumbing	<input type="checkbox"/> Exterior Plumbing
<input type="checkbox"/> Siding	<input type="checkbox"/> Cabinet Hanging	<input type="checkbox"/> Door Replacement	<input type="checkbox"/> Trim/Carpentry
<input type="checkbox"/> Stucco	<input type="checkbox"/> Window/Door Repl.	<input type="checkbox"/> Construction Cleaning	<input type="checkbox"/> Exterior Framing

AFFORDABLE HOUSING ACQUISITION

- Data Entry Receptionist Sales Telephone Customer Service
- Administrative Teaching/Training Personal Care Aid Landscaping
- CDL License Roofing Concrete/Asphalt Work Heavy Equipment Operator
- Fencing Metal/Steel Work Welding Other _____

Continued in other page

I am certifying as a Section 3: **Person seeking Training** or **Person seeking employment**

(Check all that apply):

- I am a public housing leaseholder**
- I am a Section 8 leaseholder**
- I live in the service area of the Authority (El Paso, TX)**

My total annual household income is \$_____ There are a total of _____ people living in my household

I certify that all of the information given above is true and correct. If found to be inaccurate, I understand that I may be disqualified as an applicant and/or a certified Section 3 individual which may be grounds for termination of training, employment, or contracts that resulted from this certification. I attest under penalty of perjury that my total household income annually, based on my total household size as listed above is at or below the income amount for that specific size at the time of this document is being signed. I understand that proof of this statement may be requested in the future.

Signature

Print Name

Date

AFFORDABLE HOUSING ACQUISITION



AFFORDABLE HOUSING ACQUISITION

As part of the Housing and Urban Development's (HUD) Section III initiative for providing employment opportunities for public housing residents, the Engineer will identify construction labor opportunities that may be performed by skilled and unskilled residents.

All Section 3 covered contracts shall include the following clause (referred to as the Section 3 Clause):

- A. The work to be performed under this Contract is subject to the requirements of Section 3 of the Housing and Urban Development Act of 1968, as amended, 12 U.S.C. 1701u (Section 3). The purpose of Section 3 is to ensure that employment and other economic opportunities generated by HUD assistance of HUD-assisted projects covered by Section 3, shall, to the greatest extent feasible, be directed to low-and very low-income persons, particularly persons, who are recipients of HUD assistance for housing.
- B. The parties to this Contract agree to comply with HUD's regulations in 24 CFR Part 135, which implement Section 3. As evidenced by their execution of this Contract, the parties to this Contract certify that they are under no contractual or other impediment that would prevent them from complying with part 135 regulations.
- C. The Contractor agrees to send to each labor organization or representative of workers with which the contractor has a collective bargaining agreement or other understanding, if any, a notice advising the labor organization or workers' representative of the contractor's commitments under this Section 3 Clause, and will post copies of the notice in conspicuous places at the work site where both employees and applicants for training and employment positions can see the notice. The notice shall describe the Section 3 reference, shall set forth minimum number and job titles subject to hire, availability of apprenticeship and training positions, the qualifications for each; and the name and location of the person(s) taking applications for each of the positions; and anticipated date the work shall begin.
- D. The Contractor agrees to include this Section 3 Clause in every subcontract subject to compliance with regulations in 24 CFR Part 135, and agrees to take appropriate action, as provided in an applicable provision of the subcontract or in this Section 3 Clause, upon a finding that the subcontractor is in violation of the regulations in 24 CFR Part 135. The Contractor will not subcontract with any subcontractor where the Contractor has notice or knowledge that the subcontractor has been found in violation of the regulations in 24 CFR Part 135.
- E. The Contractor will certify that any vacant employment positions, including training positions, that are filled (1) after the contractor is selected but before the Contract is executed, and (2) with persons other than those to whom the regulations of 24 CFR Part 135 require employment opportunities to be directed, were not filled to circumvent the contractor's obligations under 24 CFR Part 135.
- F. Noncompliance with HUD's regulations in 24 CFR Part 135 may result in sanctions, termination of this Contract for default, and debarment of suspension from HUD assisted contracts.

AFFORDABLE HOUSING ACQUISITION

PREFERENCE FOR SECTION 3 BUSINESS CONCERNS IN CONTRACTING OPPORTUNITIES:

Order of providing preference:

Contractor and subcontractor shall direct their efforts to award Section 3 covered contracts, to the greatest extent feasible, to Section 3 business concerns in the following order of priority:

1. Public and Indian housing programs. In public and Indian housing programs, efforts shall be directed to award contracts to Section 3 business concerns in the following order of priority:
 - a. Business concerns that are 51% percent or more owned by residents of the housing development or developments for which the Section 3 covered assistance is expended, or whose full-time, permanent workforce includes 30% percent of these persons as employees (category 1 businesses);
 - b. Business concerns that are 51% percent or more owned by residents of other housing developments or developments managed by the HA that is expending the Section 3 covered assistance, or whose full-time, permanent workforce includes 30% percent of these persons as employees (category 2 businesses); or
 - c. HUD Youth build programs being carried out in the metropolitan area (or Non- metropolitan county) in which the Section 3 covered assistance is expended (category 3 businesses).
 - d. Business concerns that are 51% percent or more owned by Section 3 residents, or whose permanent, full-time workforce includes no less than 30% percent Section 3 residents (category 4 businesses), or that subcontract in excess of 25% percent of the total amount of subcontracts to Section 3 business concerns.

Housing and community development programs. In housing and community development programs, priority considerations shall be given, where feasible, to:

- a. Section 3 business concerns that provide economic opportunities for Section 3 residents in the service area or neighborhood in which the Section 3 covered project is located (category 1 businesses); and
- b. Applicants (as this term is defined in 42 U.S.C. 12899) selected to carry out HUD Youth build programs (category 2 businesses);
- c. Other Section 3 business concerns.

AFFORDABLE HOUSING ACQUISITION

Remodeling and Renovation of 300 units at
Villa Alegre Apartments

Eligibility to preference.

A business concern seeking to qualify for a Section 3 contracting preference shall certify or submit evidence, if requested, that the business concern is a Section 3 business concern as defined in Sec. 135.5.

Ability to complete contract. A section 3 business concern seeking a contract or a subcontract shall submit evidence to the Contractor, or subcontractor (as applicable), if requested, sufficient to demonstrate to the satisfaction of the party awarding the contract that the business concern is responsible and has the ability to perform successfully under the terms and conditions of the proposed contract. (The ability to perform successfully under the terms and conditions of the proposed contract is required of all Contractors and subcontractors subject to the procurement standards of 24 CFR 85.36 (see 24 CFR 85.36 (b)(8)). This regulation requires consideration of, among other factors, the potential Contractor's record in complying with public policy requirements. Section 3 compliance is a matter properly considered as part of this determination.

AFFORDABLE HOUSING ACQUISITION

RFP OPS 18-R-0022

Remodeling and Renovation of 300 units at
Villa Alegre Apartments

PART III

DOCUMENTS, EXHIBITS AND OTHER ATTACHMENTS

AFFORDABLE HOUSING ACQUISITION

RFP OPS 18-R-0022

Remodeling and Renovation of 300 units at
Villa Alegre Apartments

SECTION E

LIST OF ATTACHMENTS

Attachment A - Form of Contract

AFFORDABLE HOUSING ACQUISITION

Remodeling and Renovation of 300 units at
Villa Alegre Apartments

**FORM OF NON-COLLUSIVE
AFFIDAVIT PRIME OFFEROR**

State of Texas
County of El Paso

_____, being first duly sworn, deposes and says:

That he is _____ (state whether a partner or officer of the firm, corp., etc.) of the party making the foregoing proposal and attests to the following:

1. That affiant employed no person, corporation, firm, association, or other organization, either directly or indirectly, to secure the public contract under which he received payment, other than persons regularly employed by the affiant whose services in securing the public contract were in the regular course of their duties for affiant; and
2. That no part of the contract price received by affiant was paid or will be paid to any person, corporation, firm, association, or other than the payment of their normal compensation to persons regularly employed by the affiant whose service in connection with the project were in the regular course of their duties for affiant.
3. That such proposal is genuine and not collusive or sham; that said offeror has not colluded, conspired, connived, or agreed, directly or indirectly, with any offeror or person, to put in a sham offer or to refrain from submitting an offer and has not in any manner, directly or indirectly, sought by agreement or collusion, or communication or conference, with any person, to fix to any overhead profit or cost element of said price, or of that of any other offeror, or to secure any advantage against the Housing Authority of the City of El Paso, Texas, or any person interested in the proposed contract, and that all statements in said proposal are true.

: _____
Signature of Offeror if Offeror
is an individual

: _____
Signatures of all partners if
Offer is a partnership

: _____
Signature of Corporate Principal if Offeror is
a corporation

Subscribed and sworn to before me

This _____ day of _____, 20_____.

My Commission expires _____, 20_____.

AFFORDABLE HOUSING ACQUISITION

RFP OPS 18-R-0022

Remodeling and Renovation of 300 units at
Villa Alegre Apartments

**CERTIFICATION OF
EQUAL EMPLOYMENT OPPORTUNITY
AGREEMENT**

I _____
(Official's Name) (Title)

of the _____ do hereby certify that I have read and
understand the EEO requirements throughout the life of this contract.

Attachment of this executed form, as such, is required to complete a valid
bid/proposal.

For Project: _____

Job to be Performed: _____

Official's Signature

Date

AFFORDABLE HOUSING ACQUISITION

RFP OPS 18-R-0022

Remodeling and Renovation of 300 units at
Villa Alegre Apartments

FEDERAL LABOR STANDARDS CERTIFICATION

I, _____, the Offeror, certify that I and all subcontractors involved in the proposed contract will comply with Federal Labor Standards and prevailing wage rates.

Signature of Offeror if Offeror is an individual
Signature of all partners of Offeror is a partnership

Company

Date

AFFORDABLE HOUSING ACQUISITION

Remodeling and Renovation of 300 units at Villa Alegre Apartments

STATEMENT OF OFFEROR'S QUALIFICATIONS

All questions must be answered and the data given must be clear and comprehensive. This statement must be notarized. If necessary, questions may be answered on separate attached sheets. The Offeror may submit any additional information he/she desires.

1. Name of Firm (Legal Name)

a. Name of President: _____

2. Permanent main office address. Including city, state and zip code, main phone number.

3. When organized (year).

4. If a Corporation, where incorporated.

5. The offeror represents that the following persons are authorized to negotiate on its behalf with the PHA in connection with this request for proposals: (list names, titles, and telephone numbers of the authorized negotiators):

Name: _____

Title: _____

Telephone Number: _____

Email: _____

(Please attach sheets if more than one person is authorized to negotiate on the firm's behalf)

AFFORDABLE HOUSING ACQUISITION

Remodeling and Renovation of 300 units at Villa Alegre Apartments

6. How many years have you been engaged in practice under your present firm name?

7. Contracts on hand: (schedule this showing gross amount of each contract and the appropriate anticipated dates of completion.)

8. General character of work performed by your company.

9. Have you ever failed to complete any work awarded to you? If so, where why? (Be specific and attach separate sheets if needed)

10. Have you ever defaulted on a contract? If so, where and why? (Be specific, attach separate sheet if needed.)

11. List the more important contracts recently completed by you, stating approximate gross cost for each, and the month and year completed.

12. List your major areas of expertise and resources available for this contract.

AFFORDABLE HOUSING ACQUISITION

Remodeling and Renovation of 300 units at Villa Alegre Apartments

13. Experience in this type of work similar in size to this project.

14. Background and experience of the President, principal members of your organization and officers. (Attach separate sheets.)

15. Please attach a letter from your bank (on bank letterhead) referencing the following information: Is your account in good standing? What year was the account established? What is the account balance (\$50,000 can be expressed as mid-five figures)?

16. Attach letters of reference from (3) firms that do business with your company, (strictly those firms who have awarded contracts to your company).

17. Will you, upon request, fill out a detailed financial statement and furnish any other information that may be required by the Housing Authority of the City of El Paso, Texas?

YES NO

a. Have you ever been a party to or otherwise involved in any action or legal proceeding involving matters related to race, color, nationality, sex, disability, age or religion? If so, give full details. (Attach separate sheets.)

b. Have you ever been accused of discrimination based upon race, color, nationality, sex, disability, age, or religion in any action or legal proceeding including any

proceeding related to any Federal Agency? If so, give full details. (Attach separate sheets.)

18. Do you provide safety training for your employees? _____ Please attach details.

19. The undersigned hereby authorized and request any person, firm or corporation to furnish any information requested by Affordable Housing Acquisition an

AFFORDABLE HOUSING ACQUISITION

Remodeling and Renovation of 300 units at
Villa Alegre Apartments

20. Affiliate of The Housing Authority of the City of El Paso, Texas in verification of the recitals comprising this Statement of Offeror's Qualifications.

Date _____ this _____ day of _____, 20____.

(Name of Offeror)

By: _____

Title: _____

State of _____)

ss

City/County of _____)

_____ Being duly sworn,
deposes

and says that he/she is the _____ of

_____ and that the answers to the foregoing
questions and all statements therein contained are true and correct.

Subscribed and sworn to before me this _____ day of _____, 20____.

(Notary Public)

My Commission Expires _____.

AFFORDABLE HOUSING ACQUISITION

Remodeling and Renovation of 300 units at
Villa Alegre Apartments

Certification Regarding Debarment and Suspension

U.S.
Department of Housing and Urban Development

Certification A: Certification Regarding Debarment, Suspension, and Other Responsibility Matters - Primary Covered Transactions

1. The prospective primary participant certifies to the best of its knowledge and belief that its principals;

a. Are not presently debarred, suspended, proposed for debarment, declared ineligible, or voluntarily excluded from covered transactions by any Federal debarment or agency;

b. Have not within a three-year period preceding this proposal, been convicted of or had a civil judgment rendered against them for commission of fraud or a criminal offense in connection with obtaining, attempting to obtain, or performing a public (Federal, State, or local) transaction or contract under a public transaction; violation of Federal or State antitrust statutes or commission of embezzlement, theft, forgery, bribery, falsification, or destruction of records, making false statements, or receiving stolen property;

c. Are not presently indicted for or otherwise criminally or civilly charged by a governmental entity (Federal, State, or local) with commission of any of the offenses enumerated in paragraph (1)(b) of this certification; and

d. Have not within a three-year period preceding this application/ proposal had one or more public transactions (Federal, State, or local) terminated for cause or default.

2. Where the prospective primary participant is unable to certify to any of the statements in this certification, such prospective participant shall attach an explanation to this proposal.

Instructions for Certification (A)

1. By signing and submitting this proposal, the prospective primary participant is providing the certification set out below.

2. The inability of a person to provide the certification required below will not necessarily result in denial of participation in this covered transaction. The prospective participant shall submit an explanation of why it cannot provide the certification set out below. The certification or explanation will be considered in connection with the department or agency's determination whether to enter into this transaction. However, failure of the prospective

primary participant to furnish a certification or an explanation shall disqualify such person from participation in this transaction.

3. The certification in this clause is a material representation of fact upon which reliance was placed when the department or agency determined to enter into this transaction. If it is later determined that the prospective primary participant knowingly rendered an erroneous certification, in addition to other remedies available to the Federal Government, the department or agency may terminate this transaction for cause of default.

AFFORDABLE HOUSING ACQUISITION

RFP OPS 18-R-0022

Remodeling and Renovation of 300 units at
Villa Alegre Apartments

4. The prospective primary participant shall provide immediate written notice to the department or agency to whom this proposal is submitted if at any time the prospective primary participant learns that its certification was erroneous when submitted or has become erroneous by reason of changed circumstances.

5. The terms **covered transaction, debarred, suspended, ineligible, lower tier covered transaction, participant, person, primary covered transaction, principal, proposal, and voluntarily excluded**, as used in this clause, have the meanings set out in the Definitions and Coverage sections of the rules implementing Executive Order 12549. You may contact the department or agency to which this proposal is being submitted for assistance in obtaining a copy of these regulations.

6. The prospective primary participant agrees by submitting this proposal that, should the proposed covered transaction be entered into, it shall not knowingly enter into any lower tier covered transaction with a person who is debarred, suspended, declared ineligible, or voluntarily excluded from participation in this covered transaction, unless authorized by the department or agency entering into this transaction.

7. The prospective primary participant further agrees by submitting this proposal that it will include the clause titled "Certification Regarding Debarment, Suspension, Ineligibility and Voluntary Exclu-

sion - Lower Tier Covered Transaction," provided by the department or agency entering into this covered transaction, without modification, in all lower tier covered transactions and in all solicitations for lower tier covered transactions.

8. A participant in a covered transaction may rely upon a certification of a prospective participant in a lower tier covered transaction that it is not debarred, suspended, ineligible, or voluntarily excluded from the covered transaction, unless it knows that the certification is erroneous. A participant may decide the method and frequency by which it determines this eligibility of its principals. Each participant may, but is not required to, check the Nonprocurement List.

9. Nothing contained in the foregoing shall be construed to require establishment of a system of records in order to render in good faith the certification required by this clause. The knowledge and information of a participant is not required to exceed that which is normally possessed by a prudent person in the ordinary course of business dealings.

10. Except for transactions authorized under paragraph (6) of these instructions, if a participant in a covered transaction knowingly enters into a lower tier covered transaction with a person who is suspended, debarred, ineligible, or voluntarily excluded from participation in this transaction, in addition to other remedies available to the Federal Government, the department or agency may terminate this transaction for cause of default.

AFFORDABLE HOUSING ACQUISITION

Remodeling and Renovation of 300 units at
Villa Alegre Apartments

Certification B: Certification Regarding Debarment, Suspension, Ineligibility and Voluntary Exclusion - Lower Tier Covered Transactions

1. The prospective lower tier participant certifies, by submission of this proposal, that neither it nor its principals is presently debarred, suspended, proposed for debarment, declared ineligible, or voluntarily excluded from participation in this transaction by any Federal department or agency.
2. Where the prospective lower tier participant is unable to certify to any of the statements in this certification, such prospective participant shall attach an explanation to this proposal.

Instructions for Certification (B)

1. By signing and submitting this proposal, the prospective lower tier participant is providing the certification set out below.
2. The certification in this clause is a material representation of fact upon which reliance was placed when this transaction was entered into. If it is later determined that the prospective lower tier participant knowingly rendered an erroneous certification, in addition to other remedies available to the Federal Government, the department or agency with which this transaction originated may pursue available remedies, including suspension and/or debarment.
3. The prospective lower tier participant shall provide immediate written notice to the person to which this proposal is submitted if at any time the prospective lower tier participant learns that its certification was erroneous when submitted or has become erroneous by reason of changed circumstances.
4. The terms **covered transaction, debarred, suspended, ineligible, lower tier covered transaction, participant, person, primary covered transaction, principal, proposal, and voluntarily excluded**, as used in this clause, have the meanings set out in the Definitions and Coverage sections of rules implementing Executive Order 12549. You may contact the person to which this proposal is submitted for assistance in obtaining a copy of these regulations.

5. The prospective lower tier participant agrees by submitting this proposal that, should the proposed covered transaction be entered into, it shall not knowingly enter into any lower tier covered transaction with a person who is debarred, suspended, declared ineligible, or voluntarily excluded from participation in this covered transaction, unless authorized by the department or agency with which this transaction originated.
6. The prospective lower tier participant further agrees by submitting this proposal that it will include this clause titled "Certification Regarding Debarment, Suspension, Ineligibility and Voluntary Exclusion - Lower Tier Covered Transaction," without modification, in all lower tier covered transactions and in all solicitations for lower tier covered transactions.
7. A participant in a covered transaction may rely upon a certification of a prospective participant in a lower tier covered transaction that it is not debarred, suspended, ineligible, or voluntarily excluded from the covered transaction, unless it knows that the certification is erroneous. A participant may decide the method and frequency by which it determines the eligibility of its principals. Each participant may, but is not required to, check the Nonprocurement List.
8. Nothing contained in the foregoing shall be construed to require establishment of a system of records in order to render in good faith the certification required by this clause. The knowledge and information of a participant is not required to exceed that which is normally possessed by a prudent person in the ordinary course of business dealings.
9. Except for transactions authorized under paragraph (5) of these instructions, if a participant in a lower tier covered transaction knowingly enters into a lower tier covered transaction with a person who is suspended, debarred, ineligible, or voluntarily excluded from participation in this transaction, in addition to other remedies available to the Federal Government, the department or agency with which this transaction originated may pursue available remedies including suspension and/or debarment.

Applicant	Date
Signature of Authorized Certifying Official	Title

AFFORDABLE HOUSING ACQUISITION

Remodeling and Renovation of 300 units at
Villa Alegre Apartments

DISCLOSURE OF LOBBYING ACTIVITIES

Approved by OMB

Complete this form to disclose lobbying activities pursuant to 31 U.S.C. 1352

0348-0046

(See reverse for public burden disclosure.)

<input type="checkbox"/> 1. Type of Federal Action: <input type="checkbox"/> a. contract <input type="checkbox"/> b. grant <input type="checkbox"/> c. cooperative agreement <input type="checkbox"/> d. loan <input type="checkbox"/> e. loan guarantee <input type="checkbox"/> f. loan insurance	<input type="checkbox"/> 2. Status of Federal Action: <input type="checkbox"/> a. bid/offer/application <input type="checkbox"/> b. initial award <input type="checkbox"/> c. post-award	<input type="checkbox"/> 3. Report Type: <input type="checkbox"/> a. initial filing <input type="checkbox"/> b. material change For Material Change Only: year _____ quarter _____ date of last report _____
4. Name and Address of Reporting Entity: Prime Subawardee Tier _____, if known: Congressional District, if known :	5. If Reporting Entity in No. 4 is a Subawardee, Enter Name and Address of Prime: Congressional District, if known :	
6. Federal Department/Agency:	7. Federal Program Name/Description: CFDA Number, if applicable : _____	
8. Federal Action Number, if known :	9. Award Amount, if known : \$ _____	
10. a. Name and Address of Lobbying Registrant (if individual, last name, first name, MI) :	b. Individuals Performing Services (including address if different from No. 10a) (last name, first name, MI) :	
11. Information requested through this form is authorized by title 31 U.S.C. section 1352. This disclosure of lobbying activities is a material representation of fact upon which reliance was placed by the tier above when this transaction was made or entered into. This disclosure is required pursuant to 31 U.S.C. 1352. This information will be available for public inspection. Any person who fails to file the required disclosure shall be subject to a civil penalty of not less than \$10,000 and not more than \$100,000 for each such failure.	Signature: _____ Print Name: _____ Title: _____ Telephone No.: _____ Date: _____	
Federal Use Only:		Authorized for Local Reproduction Standard Form LLL (Rev. 7-97)

AFFORDABLE HOUSING ACQUISITIONRemodeling and Renovation of 300 units at
Villa Alegre Apartments**INSTRUCTIONS FOR COMPLETION OF SF-LLL, DISCLOSURE OF LOBBYING ACTIVITIES**

This disclosure form shall be completed by the reporting entity, whether sub awardee or prime Federal recipient, at the initiation or receipt of a covered Federal action, or a material change to a previous filing, pursuant to title 31 U.S.C. section 1352. The filing of a form is required for each payment or agreement to make payment to any lobbying entity for influencing or attempting to influence an officer or employee of any agency, a Member of Congress, an officer or employee of Congress, or an employee of a Member of Congress in connection with a covered Federal action. Complete all items that apply for both the initial filing and material change report. Refer to the implementing guidance published by the Office of Management and Budget for additional information.

1. Identify the type of covered Federal action for which lobbying activity is and/or has been secured to influence the outcome of a covered Federal action.
2. Identify the status of the covered Federal action.
3. Identify the appropriate classification of this report. If this is a follow up report caused by a material change to the information previously reported, enter the year and quarter in which the change occurred. Enter the date of the last previously submitted report by this reporting entity for this covered Federal action.
4. Enter the full name, address, city, State and zip code of the reporting entity. Include Congressional District, if known. Check the appropriate classification of the reporting entity that designates if it is, or expects to be, a prime or sub award recipient. Identify the tier of the sub awardee, e.g., the first sub awardee of the prime is the 1st tier. Sub awards include but are not limited to subcontracts, sub grants and contract awards under grants.
5. If the organization filing the report in item 4 checks "Sub awardee," then enter the full name, address, city, State and zip code of the prime Federal recipient. Include Congressional District, if known.
6. Enter the name of the Federal agency making the award or loan commitment. Include at least one organizational level below agency name, if known. For example, Department of Transportation, United States Coast Guard.
7. Enter the Federal program name or description for the covered Federal action (item 1). If known, enter the full Catalog of Federal Domestic Assistance (CFDA) number for grants, cooperative agreements, loans, and loan commitments.
8. Enter the most appropriate Federal identifying number available for the Federal action identified in item 1 (e.g., Request for Proposal (RFP) number; Invitation for Bid (IFB) number; grant announcement number; the contract, grant, or loan award number; the application/proposal control number assigned by the Federal agency). Include prefixes, e.g., "RFP-DE-90-001."
9. For a covered Federal action where there has been an award or loan commitment by the Federal agency, enter the Federal amount of the award/loan commitment for the prime entity identified in item 4 or 5.
10. (a) Enter the full name, address, city, State and zip code of the lobbying registrant under the Lobbying Disclosure Act of 1995 engaged by the reporting entity identified in item 4 to influence the covered Federal action.

(b) Enter the full names of the individual(s) performing services, and include full address if different from 10 (a). Enter Last Name, First Name, and Middle Initial (MI).
11. The certifying official shall sign and date the form, print his/her name, title, and telephone number

According to the Paperwork Reduction Act, as amended, no persons are required to respond to a collection of information unless it displays a valid OMB Control Number. The valid OMB control number for this information collection is OMB No. 0348-0046. Public reporting burden for this collection of information is estimated to average 10 minutes per response, including time for reviewing instructions, searching existing data sources, gathering and maintaining the data needed, and completing and reviewing the collection of information. Send comments regarding the burden estimate or any other aspect of this collection of information, including suggestions for reducing this burden, to the Office of Management and Budget, Paperwork Reduction Project (0348-0046), Washington, DC 20503.

AFFORDABLE HOUSING ACQUISITION

Remodeling and Renovation of 300 units at
Villa Alegre Apartments

Bond Number _____

TEXAS STATUTORY PERFORMANCE BOND

(Penalty of This Bond must be 100% of Contract Amount)

Public Work - State of Texas

STATE OF TEXAS
COUNTY OF EL PASO

KNOW ALL MEN BY THESE PRESENTS:

That _____, a _____ of _____,
hereinafter called the Principal, and _____,

a corporation organized and existing under the laws of the State of _____, and
whose principal office is located in the City of _____, and
duly authorized to do business in the State of Texas, hereinafter called the Surety, are held and firmly bound into

AFFORDABLE HOUSING ACQUISITION AN AFFILIATE OF THE HOUSING AUTHORITY OF THE CITY OF EL PASO,
TEXAS, hereinafter called Owner, in the penal sum of _____
DOLLARS (\$ _____) in
lawful money of the United States, to be paid in EL PASO COUNTY, TEXAS for the payment of which sum well and truly to
be made, we bind ourselves, our heirs, executors, administrators and successors, jointly and severally, firmly by these presents.
Whereas, the Principal entered into a certain contract with the Owner, dated the _____

of _____, 20____, a copy of which is hereto attached and made a part hereof, for
_____, herein called the "work".

NOW THEREFORE, THE CONDITIONS OF THIS OBLIGATION IS SUCH that if the Principal shall faithfully perform the
work in accordance with plans, specifications and contract documents then this obligation shall be void: otherwise to remain in full
force and effect.

PROVIDED HOWEVER, that this bond is executed pursuant to the provisions of Chapter 2253 of the Texas Government Code,
and all liabilities on this bond shall be determined in accordance with the provisions thereof to the same extent as if copied at length
herein.

PROVIDED FURTHER, that if any legal action to be filed upon this bond, venue shall lie in EL PASO COUNTY, State of Texas,
and that the Surety, for value received hereby stipulates and agrees that no change, extension of time, alteration or addition to the
terms of the contract or to the work to be performed thereunder or the plans, specifications or drawings accompanying the same
shall in anywise affect its obligation on this bond, and it does hereby waive notice of any such change, extension of time, alteration
or addition to the terms of the contract or to the work to be performed thereunder.

IN WITNESS WHEREOF, this instrument is executed in six counterparts, each one of which shall be deemed
an original, this the _____ day of _____, A.D. 2008.

AFFORDABLE HOUSING ACQUISITION

RFP OPS 18-R-0022

Remodeling and Renovation of 300 units at
Villa Alegre Apartments

Attested:

(Address)

Principal

By _____

(Principal) Secretary

(Address)

NOTE: If Contractor is Partnership, all partners should execute bond.

AFFORDABLE HOUSING ACQUISITION

Remodeling and Renovation of 300 units at Villa Alegre Apartments

PAYMENT BOND

Public Work - State of Texas

KNOW ALL MEN BY THESE PRESENTS:

That _____ of the City of _____, County of _____, and State of _____, hereinafter called Principal, and

authorized under the laws of the State of Texas to act as surety on bonds for Principals, hereinafter called the Surety, are held and firmly bound unto AFFORDABLE HOUSING ACQUISITION AN AFFILIATE OF THE HOUSING AUTHORITY OF THE CITY OF EL PASO, TEXAS, hereinafter called the Owner, in the penal sum of

_____ DOLLARS

\$(_____) in lawful money of the United States, to be paid in EL PASO COUNTY, TEXAS for the payment whereof, the said Principal and Surety bind themselves and their heirs, administrators, executors,

successors, jointly and severally, firmly by these presents.

WHEREAS, the Principal entered into a certain contract with the Owner, dated the _____ day of _____, 20____, for _____

_____, to which the contract is hereby referred to and made a part hereof as fully and to the same extent as if copied at length, herein called the Work.

NOW THEREFORE, THE CONDITION OF THIS OBLIGATION IS SUCH that if the said Principal shall pay all claimants supplying labor and material to him or a subcontractor in the prosecution of the Work provided for in said contract, then this obligation shall be null and void: otherwise it shall remain in full force and effect.

PROVIDED, HOWEVER, that this bond is executed pursuant to the provisions of Chapter 2253 of the Texas Government Code, and all liabilities on this bond shall be determined in accordance with the provision of said Chapter to the same extent as if it were copied at length herein.

PROVIDED FURTHER, that if any legal action be filed upon this bond, venue shall lie in EL PASO COUNTY, State of Texas, and that Surety, for the value received, stipulates and agrees that no change, extension of time, alteration or addition to the terms of the contract, or to the work to be performed thereunder, or the plans, specifications or drawings accompanying the same, shall in anywise affect its obligation on this bond, and it does hereby waive notice of any such change, extension of time, alteration or addition to the terms of the contract or to the work to be performed thereunder.

MASTERS.NEW\PAYBOND.FRM L-1

PROVIDED FURTHER, that no final settlement between the Owner and the Contractor shall abridge the right of any beneficiary hereunder, whose claim may be unsatisfied.

IN WITNESS WHEREOF, this instrument is executed in six counterparts, each one of which shall be deemed an original, this the _____ day of _____, 20____

Attested:

AFFORDABLE HOUSING ACQUISITION

RFP OPS 18-R-0022

Remodeling and Renovation of 300 units at
Villa Alegre Apartments

Principal

By _____

Witness as to Principal

(Address)

Surety
Attested:

By _____

(Address)

(SEAL)

Witness as to Surety

(Address)

(Principal) Secretary

(Surety) Secretary

Note: If Contractor is Partnership, all partners should execute Bond.

AFFORDABLE HOUSING ACQUISITION

General Decision Number: TX180053 01/05/2018

TX53 Superseded General Decision Number: TX20170053

State: Texas

Construction Type: Residential

County: El Paso County in Texas.

RESIDENTIAL CONSTRUCTION PROJECTS (consisting of single family homes and apartments up to and including 4 stories.)

Note: Under Executive Order (EO) 13658, an hourly minimum wage of \$10.35 for calendar year 2018 applies to all contracts subject to the Davis-Bacon Act for which the contract is awarded (and any solicitation was issued) on or after January 1, 2015. If this contract is covered by the EO, the contractor must pay all workers in any classification listed on this wage determination at least \$10.35 per hour (or the applicable wage rate listed on this wage determination, if it is higher) for all hours spent performing on the contract in calendar year 2018. The EO minimum wage rate will be adjusted annually.

Please note that this EO applies to the above-mentioned types of contracts entered into by the federal government that are subject to the Davis-Bacon Act itself, but it does not apply to contracts subject only to the Davis-Bacon Related Acts, including those set forth at 29 CFR 5.1(a)(2)-(60). Additional information on contractor requirements and worker protections under the EO is available at www.dol.gov/whd/govcontracts.

Modification Number	Publication Date
0	01/05/2018

* SUTX1981-001 05/01/1981

	Rates	Fringes
BRICKLAYER.....	\$ 7.25	
CARPENTER.....	\$ 7.25	
CEMENT MASON/CONCRETE FINISHER...	\$ 7.25	
ELECTRICIAN.....	\$ 7.25	
FLOOR LAYER: CARPET (SOFT)		
FLOOR.....	\$ 7.34	

AFFORDABLE HOUSING ACQUISITION

	Rates	Fringes
GLAZIER.....	\$ 7.25	
Insulation Installer.....	\$ 7.25	
IRONWORKER.....	\$ 7.25	
Laborers:		
Ashpalt Rakers.....	\$ 7.25	
Mason Tenders.....	\$ 7.25	
Unskilled.....	\$ 7.25	
LATHER.....	\$ 7.25	
Painters:		
Brush.....	\$ 7.25	
Spray.....	\$ 7.25	
PLASTERER.....	\$ 7.25	
Plumbers and Pipefitters.....	\$ 7.25	
Power equipment operators:		
Backhoes.....	\$ 7.25	
Forklifts; Front End		
Loaders.....	\$ 7.25	
Graders.....	\$ 7.25	
Rockmason (FENCE).....	\$ 7.25	
ROOFER, Including Built Up, Composition and Single Ply Roofs.....	\$ 7.25	
Sheet metal worker.....	\$ 7.25	
Taper.....	\$ 7.25	
TILE SETTER.....	\$ 8.00	

AFFORDABLE HOUSING ACQUISITION

Remodeling and Renovation of 300 units at Villa Alegre Apartments

WELDERS - Receive rate prescribed for craft performing operation to which welding is incidental.

WELDERS - Receive rate prescribed for craft performing operation to which welding is incidental.

=====

Note: Executive Order (EO) 13706, Establishing Paid Sick Leave for Federal Contractors applies to all contracts subject to the Davis-Bacon Act for which the contract is awarded (and any solicitation was issued) on or after January 1, 2017. If this contract is covered by the EO, the contractor must provide employees with 1 hour of paid sick leave for every 30 hours they work, up to 56 hours of paid sick leave each year. Employees must be permitted to use paid sick leave for their own illness, injury or other health-related needs, including preventive care; to assist a family member (or person who is like family to the employee) who is ill, injured, or has other health-related needs, including preventive care; or for reasons resulting from, or to assist a family member (or person who is like family to the employee) who is a victim of, domestic violence, sexual assault, or stalking. Additional information on contractor requirements and worker protections under the EO is available at www.dol.gov/whd/govcontracts.

Unlisted classifications needed for work not included within the scope of the classifications listed may be added after award only as provided in the labor standards contract clauses (29CFR 5.5 (a) (1) (ii)).

The body of each wage determination lists the classification and wage rates that have been found to be prevailing for the cited type(s) of construction in the area covered by the wage determination. The classifications are listed in alphabetical order of "identifiers" that indicate whether the particular rate is a union rate (current union negotiated rate for local), a survey rate (weighted average rate) or a union average rate (weighted union average rate).

Union Rate Identifiers

A four letter classification abbreviation identifier enclosed in dotted lines beginning with characters other than "SU" or "UAVG" denotes that the union classification and rate were prevailing for that classification in the survey. Example: PLUM0198-005 07/01/2014. PLUM is an abbreviation identifier of the union which prevailed in the survey for this classification, which in this example would be Plumbers. 0198 indicates the local union number or district council number where applicable, i.e., Plumbers Local 0198. The next number, 005 in the example, is an internal

AFFORDABLE HOUSING ACQUISITIONRemodeling and Renovation of 300 units at
Villa Alegre Apartments

number used in processing the wage determination. 07/01/2014 is the effective date of the most current negotiated rate, which in this example is July 1, 2014.

Union prevailing wage rates are updated to reflect all rate changes in the collective bargaining agreement (CBA) governing this classification and rate.

Survey Rate Identifiers

Classifications listed under the "SU" identifier indicate that no one rate prevailed for this classification in the survey and the published rate is derived by computing a weighted average rate based on all the rates reported in the survey for that classification. As this weighted average rate includes all rates reported in the survey, it may include both union and non-union rates.

Example: SULA2012-007 5/13/2014. SU indicates the rates are survey rates based on a weighted average calculation of rates and are not majority rates. LA indicates the State of Louisiana. 2012 is the year of survey on which these classifications and rates are based. The next number, 007 in the example, is an internal number used in producing the wage determination. 5/13/2014 indicates the survey completion date for the classifications and rates under that identifier.

Survey wage rates are not updated and remain in effect until a new survey is conducted.

Union Average Rate Identifiers

Classification(s) listed under the UAVG identifier indicate that no single majority rate prevailed for those classifications; however, 100% of the data reported for the classifications was union data.

EXAMPLE: UAVG-OH-0010 08/29/2014. UAVG indicates that the rate is a weighted union average rate. OH indicates the state. The next number, 0010 in the example, is an internal number used in producing the wage determination. 08/29/2014 indicates the survey completion date for the classifications and rates under that identifier.

A UAVG rate will be updated once a year, usually in January of each year, to reflect a weighted average of the current negotiated/CBA rate of the union locals from which the rate is based.

WAGE DETERMINATION APPEALS PROCESS

1.) Has there been an initial decision in the matter? This can be:

- * an existing published wage determination
- * a survey underlying a wage determination
- * a Wage and Hour Division letter setting forth a position on a wage determination matter

AFFORDABLE HOUSING ACQUISITION

* a conformance (additional classification and rate) ruling

On survey related matters, initial contact, including requests for summaries of surveys, should be with the Wage and Hour Regional Office for the area in which the survey was conducted because those Regional Offices have responsibility for the Davis-Bacon survey program. If the response from this initial contact is not satisfactory, then the process described in 2.) and 3.) should be followed.

With regard to any other matter not yet ripe for the formal process described here, initial contact should be with the

Branch of Construction Wage Determinations. Write to:

Branch of Construction Wage Determinations
Wage and Hour Division
U.S. Department of Labor
200 Constitution Avenue, N.W.
Washington, DC 20210

2.) If the answer to the question in 1.) is yes, then an interested party (those affected by the action) can request review and reconsideration from the Wage and Hour Administrator (See 29 CFR Part 1.8 and 29 CFR Part 7). Write to:

Wage and Hour Administrator
U.S. Department of Labor
200 Constitution Avenue, N.W.
Washington, DC 20210

The request should be accompanied by a full statement of the interested party's position and by any information (wage payment data, project description, area practice material, etc.) that the requestor considers relevant to the issue.

3.) If the decision of the Administrator is not favorable, an interested party may appeal directly to the Administrative

Review Board (formerly the Wage Appeals Board). Write to:

Administrative Review Board
U.S. Department of Labor
200 Constitution Avenue, N.W.
Washington, DC 20210

AFFORDABLE HOUSING ACQUISITION

RFP OPS 18-R-0022

Remodeling and Renovation of 300 units at
Villa Alegre Apartments

4.) All decisions by the Administrative Review Board are final.

=====

END OF GENERAL DECISION

AFFORDABLE HOUSING ACQUISITION

RFP OPS 18-R-0022

Remodeling and Renovation of 300 units at
Villa Alegre Apartments

PART IV

REPRESENTATIONS AND INSTRUCTIONS

AFFORDABLE HOUSING ACQUISITION

RFP OPS 18-R-0022

Remodeling and Renovation of 300 units at
Villa Alegre Apartments

SECTION F
REQUIRED CERTIFICATIONS

AFFORDABLE HOUSING ACQUISITIONRemodeling and Renovation of 300 units at
Villa Alegre Apartments**Certifications and
Representations
of Offerors****U.S. Department of
Housing and Urban
Development**

Approval No: 2577-0180 (Gxp. 7130/96)

OMB

Office of Public and Indian Housing

Non-Construction Contract

Public reporting burden for this collection of information is estimated to average 0.08 hours per response, including the time for reviewing instructions, searching existing data sources, gathering and maintaining the data needed, and completing and reviewing the collection of information. Send comments regarding this burden estimate or any other aspects of this collection of information, including suggestions for reducing this burden, to the Reports Management Officer, Paperwork Reduction Project (2577-0180), Office of Information Technology, U.S. Department of Housing and Urban Development, Washington, D.C@ 20410-3600@

Do not send this form to the above address.

1. Contingent Fee Representation and Agreement

(Check the block applicable to you)

(a) The bidder/offeror represents and certifies as part of its bid/offer that, except for full-time bona fide employees working solely for the bidder/offeror, the bidder/offeror:

- (1) has, has not employed or retained any person or company to solicit or obtain this contract; and
- (2) has, has not paid or agreed to pay to any person or company employed or retained to solicit or obtain this contract any commission, percentage, brokerage, or other fee contingent upon or resulting from the award of this contract.

(b) If the answer to either (a)(1) or (a) (2) above is affirmative, the bidder/offeror shall make an immediate and full written disclosure to the PHA Contracting Officer.

(c) Any misrepresentation by the bidder/offeror shall give the PHA the right to (1) terminate the resultant contract; (2) at its discretion, to deduct from contract payments the amount of any commission, percentage, brokerage, or other contingent fee; or (3) take other remedy pursuant to the contract.

2. Small, Minority, Women-Owned Business Concern Representation

The bidder/offeror represents and certifies as part of its bid/ offer that it:

- (a) is, is not a small business concern. "Small business concern," as used in this provision, means a concern, including its affiliates, that is independently owned and operated, not dominant in the field of operation in which it is bidding, and qualified as a small business under the criteria and size standards in 13 CFR 12.1.
- (b) is, is not a women-owned small business concern. "Women-owned," as used in this provision, means a small business that is at least 51 percent owned by a woman or women who are U.S. citizens and who also control and operate the business.
- (c) is, is not a minority enterprise which, pursuant to Executive Order 1 1625, is defined as a business which is at least 51 percent owned by one or more minority group members or, in the case of a publicly owned business, at least 51 per cent of its voting stock is owned by one or more minority group members, and whose management and daily operations are controlled by one or more such individuals. For the purpose of this definition, minority group members are:

AFFORDABLE HOUSING ACQUISITION

RFP OPS 18-R-0022

Remodeling and Renovation of 300 units at
Villa Alegre Apartments

3. Certificate of Independent Price Determination

- (a) The bidder/offeror certifies that-
- (1) The prices in this bid/offer have been arrived at independently, without, for the purpose of restricting competition, any consultation, communication, or agreement with any other bidder/offeror or competitor relating to (i) those prices, (ii) the intention to submit a bid/offer, or (iii) the methods or factors used to calculate the prices offered-
 - (2) The prices in this bid/offer have not been and will not be knowingly disclosed by the bidder/offeror, directly or indirectly, to any other bidder/offeror or competitor before bid opening (in the case of a sealed bid solicitation) or contract award (in the case of a negotiated solicitation) unless otherwise required by law; and
 - (3) No attempt has been made or will be made by the bidder/offeror to induce any other concern to submit or not to submit a bid/offer for the purpose of restricting competition.
- (b) Each signature on the bid/offer is considered to be a certification by the signatory that the signatory:
- (1) Is the person in the bidder/offeror's organization responsible for determining the prices being offered in this bid or proposal,
- | | |
|---|---|
| <input type="checkbox"/> Black Americans | <input type="checkbox"/> Asian Pacific Americans |
| <input type="checkbox"/> Hispanic Americans | <input type="checkbox"/> Asian Indian Americans |
| <input type="checkbox"/> Native Americans | <input type="checkbox"/> Hasidic Jewish Americans |

- and that the signatory has not participated and will not participate in any action contrary to subparagraphs (a)(1) through (a)(3) above; or
- (2) (i) Has been authorized, in writing, to act as agent for the following principals in certifying that those principals have not participated, and will not participate in any action contrary to subparagraphs (a)(1) through (a)(3) above (insert full name of person(s) in the bidder/offeror's organization responsible for determining the prices offered in this bid or proposal, and the title of his or her position in the bidder/offeror's organization);
(ii) As an authorized agent, does certify that the principals named in subdivision (b)(2)(i) above have not participated, and will not participate, in any action contrary to subparagraphs (a)(1) through (a)(3) above; and
(iii) As an agent, has not personally participated, and will not participate in any action contrary to subparagraphs (a)(1) through (a)(3) above.
- (c) If the bidder/offeror deletes or modifies subparagraph (a)2 above, the bidder/offeror must furnish with its bid/offer a signed statement setting forth in detail the circumstances of the disclosure.

4. Organizational Conflicts of Interest Certification

- (a) The Contractor warrants that to the best of its knowledge and belief and except as otherwise disclosed, it does not have any organizational conflict of interest which is defined as a situation in which the nature of work under a proposed contract and a prospective contractor's organizational, financial, contractual

Form HUD-5369-C (8/93)

Page 1 of 2

ref Handbook 7460 8

AFFORDABLE HOUSING ACQUISITION

RFP OPS 18-R-0022

Remodeling and Renovation of 300 units at
Villa Alegre Apartments

or other interest are such that:

- (i) Award of the contract may result in an unfair competitive advantage;
 - (ii) The Contractor's objectivity in performing the contract work may be impaired; or
 - (iii) That the Contractor has disclosed all relevant information and requested the HA to make a determination with respect to this Contract.
- (b) The Contractor agrees that if after award he or she discovers an organizational conflict of interest with respect to this contract, he or she shall make an immediate and full disclosure in writing to the HA which shall include a description of the action which the Contractor has taken or intends to eliminate or neutralize the conflict. The HA may, however, terminate the Contract for the convenience of HA if it would be in the best interest of HA.
- (c) In the event the Contractor was aware of an organizational conflict of interest before the award of this Contract and intentionally did not disclose the conflict to the HA, the HA may terminate the Contract for default.
- (d) The Contractor shall require a disclosure or representation from subcontractors and consultants who may be in a position to influence the advice or assistance rendered to the HA and shall include any necessary provisions to eliminate or neutralize conflicts of interest in consultant agreements or subcontracts involving performance or work under this Contract. -

5. Authorized Negotiators (RFPs only)

The offeror represents that the following persons are authorized to negotiate on its behalf with the PHA in connection with this request for proposals: (list names, titles, and telephone numbers of the authorized negotiators):

6. Conflict of interest

In the absence of any actual or apparent conflict, the offeror, by submission of a proposal, hereby warrants that to the best of its knowledge and belief, no actual or apparent conflict of interest exists with regard to any possible performance of this procurement, as described in the clause in this solicitation titled "Organizational Conflict of Interest."

7. Offeror's Signature

The offeror hereby certifies that the information contained in these certifications and representations is accurate, complete, and current.

Signature & Date:

Typed or Printed Name:

Title:

AFFORDABLE HOUSING ACQUISITION

RFP OPS 18-R-0022

Remodeling and Renovation of 300 units at
Villa Alegre Apartments

SECTION G
INSTRUCTIONS TO OFFERORS

AFFORDABLE HOUSING ACQUISITION*Instructions to Offerors Non-
Construction***U.S. Department of Housing
and Urban Development**Office of Public and Indian
Housing- 03291 -**1. Preparation of Offers**

- (a) Offerors are expected to examine the statement of work, the proposed contract terms and conditions, and all instructions. Failure to do so will be at the offeror's risk.
- (b) Each offeror shall furnish the information required by the solicitation. The offeror shall sign the offer and print or type its name on the cover sheet and each continuation sheet on which it makes an entry. Erasures or other changes must be initialed by the person signing the offer. Offers signed by an agent shall be accompanied by evidence of that agent's authority, unless that evidence has been previously furnished to the HA.
- (c) Offers for services other than those specified will not be considered.

2. Submission of Offers

- (a) Offers and modifications thereof shall be submitted in sealed envelopes or packages (1) addressed to the office specified in the solicitation, and (2) showing the time specified for receipt, the solicitation number, and the name and address of the offeror.
- (b) Telegraphic offers will not be considered unless authorized by the solicitation; however, offers may be modified by written or telegraphic notice.
- (c) Facsimile offers, modifications or withdrawals will not be considered unless authorized by the solicitation.

3. Amendments to Solicitations

- (a) If this solicitation is amended, then all terms and conditions which are not modified remain unchanged.
- (b) Offerors shall acknowledge receipt of any amendments to this solicitation by
- (1) Signing and returning the amendment;
 - (2) identifying the amendment number and date in the space provided for this purpose on the form for submitting an offer,
 - (3) letter or telegram, or
 - (4) facsimile, if facsimile offers are authorized in the solicitation. The HA/HUD must receive the acknowledgment by the time specified for receipt of offers.

4. Explanation to Prospective Offerors

Any prospective offeror desiring an explanation or interpretation of the solicitation, statement of work, etc., must request it in writing soon enough to allow a reply to reach all prospective offers before the submission of their offers. Oral explanations or instructions given before the award of the contract will not be binding. Any information given to a prospective offeror concerning a solicitation will be furnished promptly to all other prospective offers as an amendment of the solicitation, if that information is necessary in submitting offers or if the lack of it would be prejudicial to any other prospective offerors.

5. Responsibility of Prospective Contractor

- (a) The HA shall award a contract only to a responsible prospective contractor who is able to perform successfully under the terms and conditions of the proposed contract. To be determined responsible, a prospective contractor must -
- (1) Have adequate financial resources to perform the contract, or the ability to obtain them;

- (2) Have a satisfactory performance record;
- (3) Have a satisfactory record of integrity and business ethics;
- (4) Have a satisfactory record of compliance with public policy (e.g., Equal Employment Opportunity); and
- (5) Not have been suspended, debarred, or otherwise determined to be ineligible for award of contracts by the Department of Housing and Urban Development or any other agency of the U.S. Government. Current lists of ineligible contractors are available for inspection at the HA/HUD.

(b) Before an offer is considered for award, the offeror may be requested by the HA to submit a statement or other documentation regarding any of the foregoing requirements. Failure by the offeror to provide such additional information may render the offeror ineligible for award.

6. Late Submissions, Modifications, and Withdrawal of Offers

- (a) Any offer received at the place designated in the solicitation after the exact time specified for receipt will not be considered unless it is received before award is made and it -
- (1) Was sent by registered or certified mail not later than the fifth calendar day before the date specified for receipt of offers (e.g., an offer submitted in response to a solicitation requiring receipt of offers by the 20th of the month must have been mailed by the 15th);
 - (2) Was sent by mail, or if authorized by the solicitation was sent by telegram or via facsimile, and it is determined by the HA/ HUD that the late receipt was due solely to mishandling by the HA/HUD after receipt at the HA;
 - (3) Was sent by U.S. Postal Service Express Mail Next Day Service - Post Office to Addressee, not later than 5:00 p.m. at the place of mailing two working days prior to the date specified for receipt of proposals. The term "working days" excludes weekends and U.S. Federal holidays; or
 - (4) Is the only offer received.
- (b) Any modification of an offer, except a modification resulting from the HA's request for "best and final" offer (if this solicitation is a request for proposals), is subject to the same conditions as in subparagraph (a)(1), (2), and (3) of this provision.
- (c) A modification resulting from the HA's request for "best and final" offer received after the time and date specified in the request will not be considered unless received before award and the late receipt is due, solely to mishandling by the HA after receipt at the HA.
- (d) The only acceptable evidence to establish the date of mailing of late offer, modification, or withdrawal sent either by registered or certified mail is the U.S. or Canadian Postal Service postmark both on the envelope or wrapper and on the original receipt from the U.S. or Canadian Postal Service. Both postmarks must show a legible date or the offer, modification, or withdrawal shall be processed as if mailed late. "Postmark" means a printed, stamped, or otherwise place impression (exclusive of a postage meter machine impression) that readily identifiable without further action as having been supplied and fixed by employees of the U.S. or Canadian Postal Service on the date of mailing. Therefore, offerors

AFFORDABLE HOUSING ACQUISITION

RFP OPS 18-R-0022

Remodeling and Renovation of 300 units at
Villa Alegre Apartments

should request the postal clerk place a hand Cancellation bull's-eye postmark on both
the receipt and the envelope or wrapper.

receipt

maintained by the HA.

(e) ~~The only acceptable evidence to establish the time of receipt at the HA is the~~

Form HUD-5369-B (8/9)

(f) time/date stamp of HA on the offer wrapper or other documentary evidence of

Previous edition is obsolete

page 1 of 2

ref. Handbook 7460

AFFORDABLE HOUSING ACQUISITION**Remodeling and Renovation of 300 units at
Villa Alegre Apartments**

(g) The only acceptable evidence to establish the date of mailing of a late offer, modification, or withdrawal sent by Express Mail Next Day Service- Post Office to Addressee is the date entered by the post office receiving clerk on the "Express Mail Next Day Service-Post Office to Addressee" label and the postmark on both the envelope or wrapper and on the original receipt from the U.S. Postal Service. "Postmark" has the same meaning as defined in paragraph (c) of this provision, excluding postmarks of the Canadian Postal Service. Therefore, offerors should request the postal clerk to place a legible hand cancellation bull's eye postmark on both the receipt and the envelope or wrapper.

(h) Notwithstanding paragraph (a) of his provision, a late modification of an otherwise successful offer that makes its terms more favorable to the HA will be considered at any time it is received and may be accepted.

(i) If this solicitation is a request for proposals, proposals may be withdrawn by written notice, or if authorized by this solicitation, by telegram (including mailgram) or facsimile machine transmission received at any time before award. Proposals may be withdrawn in person by a offeror or its authorized representative if the identify of the person requesting withdrawal is established and the person signs a receipt for the offer before award. If this solicitation is an invitation for bids, bids may be withdrawn at any time prior to bid opening.

7. Contract Award

(a) The HA will award a contract resulting from this solicitation to the responsible offeror whose offer conforming to the solicitation will be most advantageous to the HA, cost or price and other factors, specified elsewhere in this solicitation, considered.

(b) The HA may

- (1) Reject any or all offers if such action is in the HA's interest,
- (2) accept other than the lowest offer,
- (3) waive informalities and minor irregularities in offers received, and
- (4) award more than one contract for all or part of the requirements stated.

(c) If this solicitation is a request for proposals, the HA may award a contract on the basis of initial offers received, without discussions. Therefore, each initial offer should contain the offeror's best terms from a cost or price and technical standpoint.

(d) A written award or acceptance of offer mailed or otherwise furnished to the successful offeror within the time for acceptance specified in the offer shall result in a binding contract without further action by either party. If this solicitation is a request for proposals, before the offer's specified expiration time, the HA may accept an offer, whether or not there are negotiations after its receipt, unless a written, notice of withdrawal is received before award. Negotiations conducted after receipt of an offer do not constitute a rejection or counteroffer by the HA.

(e) Neither financial data submitted with an offer, nor representations concerning facilities or financing, will form a part of the resulting contract.

8. Service of Protest

Any protest against the award of a contract pursuant to this solicitation shall be served on the HA by obtaining written and dated acknowledgement of receipt from the HA at the address shown on the cover of this solicitation. The determination of the HA with regard to such protest or to proceed to award notwithstanding such protest shall be final unless appealed by the protestor.

9. Offer Submission

Offers shall be submitted as follows and shall be enclosed in a sealed envelope and addressed to the office specified in the solicitation. The proposal shall show the hour and date specified in the solicitation for receipt, the solicitation number, and the name and address of the offeror, on the face of the envelope.

It is very important that the offer be properly identified on the face of the envelope as set forth above in order to insure that the date and time of receipt is stamped on the face of the offer envelope. Receiving procedures are: date and time stamp those envelopes identified as proposals and deliver them immediately to the appropriate contracting official, and only date stamp those envelopes which do not contain identification of the contents and deliver them to the appropriate procuring activity only through the routine mail delivery procedure

AFFORDABLE HOUSING ACQUISITIONRemodeling and Renovation of 300 units at
Villa Alegre Apartments**PART IV – REPRESENTATIONS AND
INSTRUCTIONS SECTION G****INSTRUCTIONS, CONDITIONS, AND NOTICES TO OFFERORS****G-1 SOLICITATION PROVISIONS INCORPORATED BY REFERENCE**

<u>FAR NO.</u>	<u>PROVISION TITLE</u>	<u>DATE</u>
52.215-1	Instructions to Offerors – Competitive Acquisition	OCT 1987
52.216-1	Type of Contract	APR 1984
G-2	All proposals must be mailed or delivered to: Affordable Housing Acquisition an Affiliate of The Housing Authority of the City of El Paso, Texas 5300 E. Paisano Dr. El Paso, Texas 79905	

NOTE: It is the vendor's sole responsibility to see that his/her proposal is received at the proper place on time.

G-3 If any prospective vendor is in doubt as to the true meaning of any portion of the proposal documents or requires any additional information to prepare his/her proposal response, he/she shall contact, in writing, to the Contracts Division at the above referenced address no later than 7 days before the closing date of the solicitation.

G-4 Proposals shall be dated with each page numbered and displaying the offeror's identification. Signatures required shall be in longhand and by those authorized to execute an eventual contract.

G-5 No oral, telegraphic, or telephonic proposals or modifications will be considered.

G-6 The completed proposal shall answer all questions on a point-by-point basis in a concise manner, avoiding ambiguous statements and shall be without interlineations, alterations, and erasures.

G-7 All deviations to the proposal Statement of Work or any items or features that cannot or should not be solicited must be specifically identified. If no such areas of controversy are identified, the proposal should so state and it shall be understood that all items, features and costs have been included.

G-8 If the offeror is unable to comply with a requirement but is uncertain to the specific nomenclature in any specification, it shall enter a reference number of any supporting documents, etc., describing or interpreting the requirement.

G-9 All statements made by the offeror must be capable of being included into a written contract.

G-10 All documentation submitted automatically becomes the property of the Housing Authority of the City of El Paso, Texas.

G-11 Expenses for proposal development are entirely the responsibility of the offeror and will not be chargeable in any manner to Affordable Housing Acquisition an Affiliate of the Housing Authority of the City of El Paso, Texas.

G-12 Affordable Housing Acquisition an Affiliate of The Housing Authority of the City of El Paso, Texas reserves the right to accept or reject any proposal, or any part of a proposal. Any resulting order will be awarded to that responsive, responsible offeror, whose proposal is most advantageous to the Housing Authority of the City of El Paso, Texas, all other factors considered.

AFFORDABLE HOUSING ACQUISITIONRemodeling and Renovation of 300 units at
Villa Alegre Apartments

G-13 Offeror must submit proof of all insurance coverages and be prepared to provide additional proof of same should the Affordable Housing Acquisition an Affiliate of The Housing Authority of the City of El Paso, Texas so request.

G-14 Offeror must provide financial information, including bank references, annual report, and a detailed financial statement at the request of AHA.

G-15 All offers will be evaluated according to the criteria listed in the proposal. To be considered responsive the offer must respond to the criteria.

G-16 PROTEST TO THE AGENCY

(a) When a protest is filed with the agency, an award shall not be made until the matter is resolved unless the Director of Contracting or other designated official first determines that one of the following applies:

- (1) The supplies or services to be contracted for are urgently required.
- (2) Delivery or performance will be unduly delayed by failure to make award promptly.
- (3) A prompt award will otherwise be advantageous to Affordable Housing Acquisition an Affiliate of The Housing Authority of the City of El Paso, Texas.

G-17 (52.252-1) SOLICITATIONS PROVISIONS INCORPORATED BY REFERENCE (JUNE 1988)

This solicitation incorporates one or more solicitation provisions by reference with the same force and effect as if they were given in full text. Upon request, the Director of Contract Compliance will make their full text available.

G-18 AWARD

Affordable Housing Acquisition an Affiliate of The Housing Authority of the City of El Paso, Texas, at its discretion, may award multiple contracts for this requirement.

G-19 INCURRING COSTS

(a) Costs shall not be incurred by receipts of the solicitation document in the anticipation of receiving direct reimbursement from the Affordable Housing Acquisition an Affiliate of The Housing Authority of the City of El Paso, Texas without the written authorization of the proper authority.

Affordable Housing Acquisition an Affiliate of The Housing Authority of the City of El Paso, Texas assumes no liability for and shall not be obligated to the Contractor for payment for the Contractor's costs incurred prior to award.

G-20 PRE-AWARD SURVEY OF PROSPECTIVE CONTRACTOR

(a) If an offer submitted in response to this solicitation that is favorably considered, a survey team may contact your facility to determine your ability to perform. Current financial statements and other pertinent data should be available for review at that time if not already on file with the office having cognizance over your facility. Areas that may be investigated or evaluated are listed below:

1. Technical Capability
2. Facilities
3. Financial Capability
4. Accounting System
5. Quality Assurance
6. Performance record

(b) Offerors are advised that accomplishment of this survey is a part of the evaluation process and is not to be construed as an indication that and will receive or is in the best position to receive the resultant award.

(c) Affordable Housing Acquisition an Affiliate of The Housing Authority of the City of El Paso,

AFFORDABLE HOUSING ACQUISITION

Remodeling and Renovation of 300 units at
Villa Alegre Apartments

Texas may conduct a pre-award survey on more than one at a time.

G – 21 FAILURE TO SUBMIT OFFER

Recipients of this solicitation not responding with an offer should not return this solicitation, unless it specifies otherwise. Instead, they should advise the issuing office by letter, postcard, or established electronic commerce methods, whether they want to receive future solicitations for similar requirements. If a recipient does not submit an offer and does not notify the issuing office that future solicitations are desired, the recipient's name may be removed from the applicable mailing list.

G-22 (9505) ORGANIZATIONAL CONFLICTS OF INTEREST

The Contracting Officer shall award the contract to the apparent successful offeror unless a conflict of interest is determined to exist that cannot be avoided or mitigated.

AFFORDABLE HOUSING ACQUISITION

RFP OPS 18-R-0022

Remodeling and Renovation of 300 units at
Villa Alegre Apartments

SECTION H
EVALUATION FACTORS FOR AWARD

AFFORDABLE HOUSING ACQUISITION

Remodeling and Renovation of 300 units at
Villa Alegre Apartments

CONTRACT AWARD

Only written proposals will be considered. AHA reserves the right to reject any proposals without further discussion or negotiations, and may waive technical errors or discrepancies if it serves the public interest. This solicitation for proposals is not to be considered a contract of any kind.

It is mandatory that interested Contractor/Contractors do a walk thru to inspect and assess the buildings to get a correct assessment and requirements of this RFP. Mandatory visit is to take place on July 24, 2018 between 8:30AM to 12:00PM MST prior to Pre-Proposal Meeting.

Written proposals will be reviewed, with emphasis on capacity and services proposed. Negotiations (interviews) may be conducted with all offerors in the acceptable range, at the discretion of the Affordable Housing Acquisition an Affiliate of The Housing Authority of the City of El Paso, Texas. All offerors in the competitive range will be asked to submit their Best and Final Offer. Thereafter, a recommendation for award of contract will be made to the Board of Commissioners. Upon approval by the AHA Board of Commissioners, a contract will be awarded. AHA reserves the right to exclude identified services from the contract and to award more than one contract.

After demonstrating full compliance with federal regulations at 24 CFR Part 85, Administrative Requirements (Federal Procurement, Competitive Negotiation Standards) and with all required approvals, AHA will prepare a final contract document for execution and approval by the Contracting Officer and the contracting party.

No contract will be awarded for proposals that do not meet the satisfaction of the Board of Commissioners. Any contract awarded as a result of this Request for Proposals will be made only for the term outlined in the RFP. AHA reserves the right to cancel unilaterally any contract derived from this Request for Proposals for failure to perform services satisfactorily. Any contract for the stated services or products herein is not an exclusive contract. AHA reserves the right to assign other service providers to such matters as it deems necessary.

AFFORDABLE HOUSING ACQUISITION

Remodeling and Renovation of 300 units at
Villa Alegre Apartments

AFFIRMATIVE ACTION

AHA is an equal opportunity employer and requires all of its contractors to comply with policies and regulations concerning equal employment opportunity. Proposals should refer to affirmative action guidelines published by the Department of Housing and Urban Development regarding minority, women-owned, handicapped, and small business enterprises. In addition, AHA requests information regarding the ethnicity of each partner, shareholder, and personnel employed by the company.

AFFORDABLE HOUSING ACQUISITION

Remodeling and Renovation of 300 units at Villa Alegre Apartments

TECHNICAL EVALUATION

WORK SHEET

Name: _____

Reviewer: _____

Date: _____

INSTRUCTIONS: Evaluation of technical proposals will be based upon an analysis of the Offeror’s proposal in relation to the criteria contained in the request for proposal. This evaluation sheet is keyed to those criteria. Reviewers should record their evaluation of each proposal in terms of its strengths and weaknesses, the degree to which the proposal possesses or lacks the attributes set forth in the specific factors for award Points scores are to be assigned to each evaluation factor as indicated below. Reviewer’s comments should be provided on this form. Additional sheets may be attached as necessary.

OVERALL SCORE: Evaluation sheets are provided for assistance in evaluated factors and weights contained in the RFP. Predetermined cut-off scores designed for determining overall rating shall not be employed.

COMPOSITE SCORE:

STRENGTHS/WEAKNESSES: (Evaluators should comment here on strengths/weakness of the technical proposal. Comments may be used to formulate Affordable Housing Acquisition an Affiliate of The Housing Authority of the City of El Paso, Texas position if continued negotiations are required).

Acceptable: _____

(“This means that based upon the proposal as submitted, the PHA could contract with the offeror and expect that the work would be completed. The proposal is not perfect, but it contains no significant weaknesses”)

Potentially Acceptable: _____

(“This means that the technical part of the proposal contains weaknesses that keep it from being acceptable, but with relatively minor changes or additional information from the offeror, it might be made acceptable. Once additional information is obtained via initial negotiations, this type of proposal must become either acceptable or unacceptable”)

Unacceptable: _____

(“This means that the proposal is seriously flawed to the point that no amount of negotiation would lead to improve it, or the offer would have to be substantially rewritten to be found acceptable. Either the offeror simply did not understand the PHA’s requirement or did not elect to prepare a sufficient proposal. Technically unacceptable proposals should never be included in a competitive range”)

AFFORDABLE HOUSING ACQUISITION

RFP OPS 18-R-0022

Remodeling and Renovation of 300 units at Villa Alegre Apartments

EVALUATION CRITERIA FACTORS FOR AWARD Remodeling and Renovation of 300 units at Villa Alegre Apartments

OPS 18-R-0022

Any award to be made pursuant to this RFP will be based upon the proposal that would provide the best value to AHA, with appropriate consideration given to operational, technical, cost, and management requirements. Evaluation of offers will be based upon the Vendor's responsiveness to the RFP and the total price quoted for all items covered by the RFP.

The following elements will be the primary considerations in evaluating all submitted proposals and in the selection of Vendors:

- | | |
|---|-----------|
| 1. Experience: how long has company been in business | 15 |
| 2. Quality of the Work Plan & Schedule: must meet the
Scheduled 70 maximum calendar days | 25 |
| 3. Qualifications and Experience of Proposed Staff | 10 |
| 4. Demonstrated Understanding of the Requirement | 15 |
| 5. Price/Cost | 35 |

AHA may, at its discretion and without explanation to the prospective Vendors, at any time choose to discontinue this RFP without obligation to such prospective Vendors.

AFFORDABLE HOUSING ACQUISITION

RFP OPS 18-R-0022

Remodeling and Renovation of 300 units at
Villa Alegre Apartments

SECTION I

TRAVEL REIMBURSEMENT GUIDELINES

AFFORDABLE HOUSING ACQUISITION

Remodeling and Renovation of 300 units at Villa Alegre Apartments

Effective July 1, 2014, Affordable Housing Acquisition an Affiliate of The Housing Authority of the City of El Paso (HACEP) implemented the following guidelines applicable to all contractor business travel.

HACEP will reimburse based on the **GSA Per Diem Rates** www.gsa.gov/perdiem for the City of El Paso, TX:

- Lodging
- Meals and Incidentals Expenses

The following categories define HACEP expectations for Contractor travel and meal expenses. Proper documentation must be submitted with the Contractor invoice before HACEP will consider reimbursement of travel or meal expenses. Such documentation must include detailed receipts for all requested amounts and the valid business reason for the expense. In addition, where HACEP management approval is required prior to reimbursement, Contractor must submit a memo detailing management’s approval or the signature of the appropriate HACEP management representative on the detailed receipt. HACEP reserves the right to request additional information when assessing payment and may refuse or limit payment based on the documentation, or lack thereof, provided.

- **Airfare** - Airfare is reimbursed at commercial Coach Class using lowest logical airfare and advance purchase options. Airfare should be booked as soon as practical to obtain best pricing options. HACEP allows non-stop service to be considered as lowest logical airfare. HACEP will not reimburse unused tickets, airport ticket class changes, or seat location upgrades. Use of non-commercial air service is expressly prohibited.
- **Tolls and Parking** – Parking will be reimbursed at actual cost for business trip expense. Commuter tolls and parking within city metropolitan area where work is performed is not reimbursable.
- **Transportation Services** - While scheduled transportation service using airport shuttles is permitted with proper receipts, private limousine or luxury shuttle service is **not reimbursable**. Taxi service is allowed in lieu of auto rental, however receipts must be provided.
- **Personal Vehicle** - Use of a personal vehicle in lieu of public transportation or a rental car is permitted when pre-approved by HACEP management. Mileage must be tracked on a daily trip log and reimbursement will be calculated at IRS standard mileage rates. Reported mileage must exclude normal commute mileage in accordance with IRS commute definitions. No personal vehicle expense, including gasoline or car repairs, is allowed for reimbursement.
- **Entertainment** - Casual entertainment including alcoholic beverages is **not reimbursable**. HACEP management must pre-authorize any scheduled group events and such events must be limited to specific milestone or project recognition events. HACEP will not reimburse Contractor for entertaining HACEP employees without prior HACEP management approval.

Sincerely,

Satish Bhaskar

AHA Chief Financial Officer

I certify that I have Read and acknowledge HACEP’s Travel/expense Guidelines.

Name and title: _____ date: _____

AFFORDABLE HOUSING ACQUISITION

RFP OPS 18-R-0022

Remodeling and Renovation of 300 units at
Villa Alegre Apartments

SECTION J
VENDOR INFORMATION FORM

AFFORDABLE HOUSING ACQUISITIONRemodeling and Renovation of 300 units at
Villa Alegre Apartments**Vendor Information Form**

Firm Name	
Firm Address (full address):	
Firm Telephone Number:	
Firm Fax Number	
Firm Year Established:	
Types of services provided by the Firm	
Federal TAX ID #	

Management person responsible for direct contact with the HACEP and services required for this Request for Proposal (RFP):

Name:	
Title:	
Telephone Number:	
Fax:	
Email:	

Person responsible for day-to-day servicing of the account:

Name:	
Title:	
Telephone Number:	
Fax:	
Email:	

AFFORDABLE HOUSING ACQUISITION

RFP OPS 18-R-0022

Remodeling and Renovation of 300 units at
Villa Alegre Apartments

Attachment A

**CONTRACT BETWEEN AFFORDABLE HOUSING ACQUISITION AN AFFILIATE
OF THE HOUSING AUTHORITY OF THE CITY OF EL PASO AND**

XXXXXXXXXXXXXX.

INTRODUCTION

This Contract (the “Contract”) by and between **Affordable Housing Acquisition an Affiliate of The Housing Authority of the City of El Paso**, a profit state governmental entity (hereinafter “AHA”) and **XXXXXXXXXXXXXX.** (hereinafter “the Contractor”) is hereby entered into this XX day of XXXX, 2018 (the “Effective Date”).

1.0 Definitions

- 1.1 Procurement Administration (“AHA PROCUREMENT MANAGER”).**
AHA Procurement Manager.
- 1.2 Request for Proposals (“RFP”).** A competitive solicitation process conducted by AHA wherein an award is generally made to the top-rated responsive and responsible bidder.
- 1.3 Days.** All references to “days” shall be calendar days; in the case that the last day referenced falls on a Saturday, Sunday or legal holiday, then the period of time shall be automatically extended to include the next work day.
- 1.4 Project.** All references to the “Project” shall mean the **XXXXXXXXXXXXXX.**
- 1.5 Appendices.** The following documents are included in the Contract as individually noted exhibits and shall be incorporated herein and made a part of this Contract by reference as if fully set forth herein:
- 1.6** The following, each of which was either issued by AHA as a part of the competitive solicitation and/or which was completed and returned by the Contractor in response to the solicitation (copies are not included under any of the appendices but are included herein by reference and are included within the solicitation file):
 - 1.6.1** Current Insurance Certificate/Endorsement (naming AHA or affiliate as “additional insured”);
 - 1.6.2** Supplementary Instructions to Offerors;
 - 1.6.3** Non-Collusive Affidavit – Prime Offeror
 - 1.6.4** Texas Statutory Performance Bond
 - 1.6.5** Payment Bond;

RFP OPS 18 XXXXXXXX
XXXXXXXXXXXXXXXX

1.6.6 Subcontractor Identification

1.6.7 Contractor’s and Subcontractor’s Non-Conclusive Affidavits;

1.6.8 Scope of Work included as part of RFP Package OPS XXXXXXXX;

1.7 **Term of Contract.** Services pursuant to this Contract (the “Services”) shall begin upon Contractor’s receipt of the written Notice to Proceed by AHA. Notwithstanding the continuation of any warranties contained herein, this Contract shall terminate upon Final Completion.

1.8 Services and Payment

1.9 **Scope of Services.** The Contractor shall furnish all labor, material, equipment and services, and perform and complete all work required for the XXXXXXXXXXXXXXXX, El Paso, TX 799XX in accordance with this Agreement and RFP No. OPS 18-RXXXX prepared by AHA and any duly executed Addenda to this Agreement. Said labor, materials, equipment and services shall be provided on the dates and times determined by AHA at the above-stated AHA communities and/or facilities. In addition, AHA shall retain the right to implement and/or enforce any item issued as a part of RFP No. OPS 18-R-XXXX.

1.7 Cost/Value of Services

1.7.1 **Labor Costs.** The Contractor shall not pay wages that are less than the highest wage required by either of the following:

1.7.1.1 The wage determination rates listed in RFP No. OPS 18-R-XXXX

1.7.2 **Contract Value.**

1.7.3 AHA shall pay the Contractor for the performance of the Contract, in current funds, subject to additions and deductions as provided in the Technical Specifications, not-to-exceed (“NTE”) the sum of:

XXXXXXXXXX

Contractor exceeds the above-stated NTE amount at its own risk.

1.7.4 **Time for Performance.** The Contractor hereby agrees to commence work under this Contract upon receipt of a written Notice to Proceed (“NTP”), submitted by AHA. The Contractor shall complete the project within XXXXXXXXXX (XXX) calendar days.

1.7.4.1 **Commencement of Work.** Contractor shall not commence work under this contract until all necessary permits and

RFP OPS 18 XXXXXXXX
XXXXXXXXXXXXXXXX

approvals, including modification thereof, that are preconditions to commencement of construction of the Project have been issued.

1.7.4.2 Delays/Time Extensions. Time extensions for performance may be granted by AHA Procurement Manager and AHA Chief Executive Officer. Any time extension shall be granted by written modification to this Contract.

1.7.4.3 Final Completion. The Contractor shall notify AHA Procurement Manager, in writing, as to the date when in its opinion the work is substantially complete and ready for inspection. Upon receipt of such notification, AHA shall conduct an inspection of the work within ten (10) days. AHA shall promptly advise the Contractor, in writing, of any remaining final punch list items following such inspection. The Contractor shall notify AHA in writing when all punch list items have been completed and all clean-up has been done. AHA will then conduct a final inspection within ten (10) days of receipt of such notification. Performance shall be considered complete upon the Contractor's receipt from AHA of written acceptance of the work and AHA's receipt from the Contractor of the following:

1.7.4.3.1.1 the total amount due the Contractor and a separately stated amount for each unsettled claim against AHA;

1.7.4.3.1.2 documentation noting that AHA is released of all claims, other than those stated in the Contractor's release;

1.7.4.3.1.3 wages paid to laborers were paid as required herein; and

1.7.4.3.1.4 all guaranties and warranties contained herein are assigned to AHA.

1.7.5 Liquidated Damages. Pursuant to Page 3, section #4 of RFP, the Contractor agrees to pay to AHA, the sum of **\$0.0** per day/building as fixed, agreed, liquidated damages for each consecutive calendar day beyond the time for performance provided in this Contract is not terminated until Final Completion is achieved.

1.7.6 Non-Escalation. Unless otherwise specified within the RFP documents, the unit prices reflected in this Contract shall remain firm with no provision for price increases during the term of the Contract.

1.8 Billing Procedure

1.8 To receive payment for Services rendered pursuant to this Contract, the Contractor shall:

1.8.1 Submit all certified payroll reports up to the date of the work being billed.

1.8.2 Progress payments must be approved by AHA Procurement Manager and AHA Chief Executive Office.

1.8.3 Progress payment requests shall be delivered to the attention of:

Affordable Housing Acquisition an Affiliate of
The Housing Authority of the City of El Paso
Attn: Accounts Payable
5300 E. Paisano Drive
El Paso, TX 79905-2931

1.8.4 The AHA will pay each properly completed invoice received on a Net/30 basis. Any invoice received that is not properly completed will not be paid unless and/or until the Contractor complies with the applicable provisions of this contract.

1.8.5 Final payment will be made by AHA upon receipt of the Contractor's all required payroll reports have been received and any wage discrepancies have been resolved by the Contractor.

2.0 Term of Contract. Services pursuant to this Contract (the "Services") shall begin upon Contractor's receipt of the written Notice to Proceed by AHA. Notwithstanding the continuation of any warranties contained herein, this Contract shall terminate upon Final Completion.

3.0 Contractor's Obligations. Pursuant to this Contract, the Contractor agrees to provide the specific construction obligations detailed in the Scope of Work issued by AHA included in RFP No. OPS 18-R-XXXX and herein.

3.1 The Contractor agrees not to accept or perform any assigned work initiated by a contract amendment or change order without the prior written approval of AHA Procurement Manager and AHA Chief Executive Officer.

3.1.1 Change Order Requests: The Contractor acknowledges, by signature below, that change order requests will not be summarily approved. All

change order requests must be submitted to AHA for approval, prior to undertaking the additional work.

- 3.1.2 Minimum Rates of Pay.** The Contractor shall pay not less than the wages required under the wage determination rates included in RFP No. **OPS 18-R-XXXX** and any amendments thereto.
- 3.2 Supervision and Oversight.** The Contractor shall be solely responsible for providing supervision and oversight to all of the Contractor's personnel and any subcontractors that are assigned to AHA work pursuant to this Contract.
- 3.3 Qualified Personnel.** The Contractor warrants and represents that it will assign only qualified personnel to perform the Services. For the purposes of this Contract, the term "qualified personnel" shall mean those personnel that are experienced and/or trained in the manner generally accepted within the Contractor's Industry.
- 3.4 Compliance with Federal and State Laws.** All work performed by the Contractor, pursuant to this Contract, shall be done in accordance with all applicable federal, state and local laws, regulations, codes and ordinances.
- 3.5 Licensing.** The Contractor shall provide AHA with copies of any required current City, State and/or Federal licenses. Failure to maintain these licenses in a current status during the term(s) of this Contract shall constitute a material breach thereof.
- 3.6 Permits.** Unless otherwise stated in the Contract documents, all local, state or federal permits, environmental permits, and licenses which may be required to provide the Services ensuing from award of this Contract, whether or not known to either AHA or the Contractor at the time of the Contract execution, shall be the sole responsibility of the Contractor including any and all costs therefore.
- 3.7 Government Standards.** It is the responsibility of the Contractor to ensure that all items and services proposed conform to all local, state and federal law concerning safety (e.g., OSHA and NIOSH) and environmental control (e.g., EPA and City of El Paso Health and Safety Code, and any other enacted ordinance, code, law or regulation. The Contractor shall be responsible for all costs incurred for compliance with any such possible ordinance, code, law or regulation. No time extensions shall be granted or financial consideration given to the Contractor for time or monies lost due to violations of any such ordinance, code, law or regulations that may occur.
- 3.8 Work on AHA Property.** If the Contractor's work under the Contract involves operations by the Contractor on AHA premises, the Contractor

shall take all necessary precautions to prevent the occurrence of any injury to persons or property during the progress of such work.

- 3.9 Subcontractors.** Unless otherwise stated within the RFP bid documents, the Contractor may not use any subcontractors to accomplish any portion of the Services required by this Contract without the prior written permission of AHA Procurement Manager.
- 3.10 Salaries and Expenses Relating to the Contractor's Employees.** Unless otherwise stated within the RFP documents, the Contractor shall pay all salaries and expenses of, and all federal Social Security taxes, federal and state unemployment taxes, and any similar taxes relating to its employees used in the performance of the Contract. The Contractor further agrees to comply with all federal, state and local wage and hour laws and all licensing laws applicable to its employees or other personnel furnished under this Contract.
- 3.11 Communication.** If during the period of the Contract, it is necessary that AHA place toll or long distance telephone calls or facsimiles in connection with the Contractor's performance of the Contract (for complaints, adjustments, shortages, failure to deliver, etc.), it is understood that the Contractor may, at the discretion of AHA, bear the charge or expense for all such calls and/or facsimiles.
- 3.12 Access to Records.** Both parties hereby agree that the Contractor will make available to AHA, the Comptroller General of the United States, or any of their duly authorized representatives (including retained auditors), any books, documents, papers, and records of the Contractor which are directly pertinent to this Contract for the purpose of making audit, examination, excerpts and transcriptions.
- 3.13 Record Retention.** The Contractor shall retain all such records pertaining to this Contract for a period of not less than three (3) years after final payment or the completion of any Services provided pursuant to this Contract, whichever occurs later.
- 3.14 Backorders**
- 3.14.1** The Contractor must notify AHA Procurement Manager within ten (10) days of the following:
- 3.14.1.1** Any and all backordered materials;
 - 3.14.1.2** Any delay in the Contractor's performance; and
 - 3.14.1.3** The estimated date for delivery or performance.

3.15 Inspections. The Contractor shall permit AHA to conduct periodic inspections of the work. Any deficiencies noted by AHA during inspections shall be disclosed to the Contractor in writing within Five (5) days of discovery, and the Contractor shall remedy such deficiency within Five (5) calendar days of notification of such from AHA or as otherwise agreed to in writing by both parties.

4.0 Insurance Requirements

4.1 The Contractor shall maintain insurance coverage during the effective term(s) of this Contract No. **OPS 18-C-XXXX**.

4.2 The Contractor shall provide AHA with current certificate(s)/endorsement(s) evidencing the insurance coverage referenced above. Failure to maintain the above-referenced insurance coverage, including naming AHA as an additional insured (where appropriate) during the term(s) of this Contract shall constitute a material breach thereof.

4.3 Insurance certificate(s)/endorsement(s) shall be delivered to:

Juan Pulido
Procurement Manager
c/o Affordable Housing Acquisition an Affiliate of
The Housing Authority of the City of El Paso
5300 E. Paisano Drive
El Paso, TX 79905-2931

5.0 Indemnification

5.1 The Contractor shall protect, indemnify and hold AHA or subsidiaries, its officers, employees, and agents harmless from and defend against any and all claims, damages, losses, suits, actions, decrees, judgments, attorney's fees, court costs and other expenses of any kind or character which AHA, its officers, employees, agents, consulting engineers or other retained consultants may suffer, or which may be sought against, recovered from or obtainable against AHA, its officers, employees, and agents, based upon the Contractor's actions or failure to act during the performance of the Contractor's duties hereunder, or as a result of any work performed by the Contractor, regardless of when such claims shall arise. The Contractor's duty to indemnify AHA shall apply regardless of whether or not the event which gave rise to such a claim was caused, in part, by AHA.

- 5.2 Any money due by the Contractor under and by virtue of this Contract which is considered necessary by AHA for such purpose, may be retained by AHA for its protection; or in case no money is due, its surety may be held until all such claims, damages, losses, suits, actions, decrees, judgments, attorney's fees and court costs and other expenses of any kind or character as aforesaid shall have been settled and suitable evidence to that effect furnished to AHA provided, however, that money due the Contractor will not be withheld when the Contractor produces satisfactory evidence that it is adequately protected by applicable public liability and property damage insurance;
- 5.3 The Contractor shall, at its own expense, defend AHA, its officers, employees, and agents, against any and all claims, suits or actions which may be brought against them, or any of them, as a result of, or by reason of, or arising out of, or on account of, or in consequence of any act or failure to act the consequences of which the Contractor has indemnified AHA, its officers, employees, and agents against. If the Contractor fails to do so, AHA shall have the right, but not the obligation, to defend the same and to charge all direct and incidental costs of such defense to the Contractor including attorney's fees and court costs.
- 5.4 The Contractor guarantees the payment of all claims for materials, supplies and labor, and all other claims against it or any subcontractor, in connection with the Contract.
- 5.5 The Contractor shall provide that any authorized contractual arrangement with a subcontractor shall be in conformance with the terms of this Contract including the indemnity provisions of this Section 8.

6.0 Financial Viability and Regulatory Compliance

- 6.1 The Contractor warrants and represents that its corporate entity is in good standing with all applicable federal, state and local licensing authorities and that it possesses all requisite licenses to perform the Services required by this Contract. The Contractor further warrants and represents that it owes no outstanding federal, state or local taxes or business assessments.
- 6.2 Contractor agrees to promptly disclose to AHA any IRS liens or insurance or licensure suspension or revocation that may adversely affect its capacity to perform the Services required by this Contract. The failure by the Contractor to disclose such issue to AHA in writing within five (5) days of Contractor's receipt of such notification will constitute a material breach of this Contract.
- 6.3 Pursuant to Section 231.006, Texas Family Code, Contractor warrants and represents that it is not ineligible to receive the award of or payments under

RFP OPS 18 XXXXXXXX
XXXXXXXXXXXXXXXX

this Agreement and acknowledges that this Agreement may be terminated and payment may be withheld if this certification is inaccurate.

- 6.4 Pursuant to Section 2155.004, Texas Government Code, Contractor warrants and represents that the individual or business entity named in this Agreement is not ineligible to receive the award of or payments under this Agreement and acknowledges that this Agreement may be terminated and payment withheld if this certification is inaccurate.
- 6.5 A corporate or limited liability company Contractor warrants and represents that it is not currently delinquent in the payment of any Franchise Taxes due under Chapter 171 of the Texas Tax Code.
- 6.6 The Contractor further agrees to promptly disclose to AHA any change of its ownership and/or any declaration of bankruptcy that the Contractor may undergo during the term(s) of this Contract. The failure of the Contractor to disclose any change of its ownership and/or its declaration of bankruptcy within five (5) days of said actions shall constitute a material breach of this Contract.

7.0 Disputes

8.0 **Breach.** Pursuant to 2 CFR 200.339 as issued by the Office of the Secretary, AHA and the Contractor each agree to comply with the following provisions:

- 8.1 **Termination For Cause and Convenience.** AHA may terminate this Contract for cause. AHA may also terminate this Contract for convenience. Any termination notice shall state the following:
 - 8.1.1 whether the Contract is being terminated for convenience or cause;
 - 8.1.2 whether the Contract is terminated in whole or in part;
 - 8.1.3 if terminated for cause, the acts or omissions constituting the material breach, AHA Procurement Manager's determination that failure to perform is not excusable, AHA's right to charge excess costs of re-procurement to the Contractor, and the Contractor's appeal rights;
 - 8.1.4 effective date of termination;
 - 8.1.5 if applicable, the Contractor's right to proceed under the non-terminated portion of the Contract; and
 - 8.1.6 any special instructions.
- 8.2 Prior to termination, AHA may choose, at its sole discretion, to warn the Contractor, verbally or in writing, of any issue of non-compliant or

unsatisfactory performance. Such warning may include placing the Contractor on probation, thereby giving the Contractor a certain period of time to correct the deficiencies or potentially suffer termination. AHA shall maintain in the Contract file a written record of any such warning detailing all pertinent information. If the Contractor does not agree with such action, the Contractor shall have ten (10) days from receipt of such verbal or written warning to dispute or protest such action in writing; if it does not do so within the 10-day period, it shall have no recourse but to accept AHA's position on the issue. The written protest must detail all pertinent information pertaining to the dispute, including any justification detailing AHA's alleged incorrect action(s).

- 8.3 After termination, if the Contractor does not agree with AHA's justification for the termination, the Contractor shall have ten (10) days from the date of termination to dispute such action in writing.
- 8.4 Any protest or dispute submitted by the Contractor under this Section shall thereafter be conducted in accordance with Section 9.1 herein.
- 8.5 All rights and remedies granted to AHA herein and any other rights and remedies which AHA may have at law and in equity are hereby declared to be cumulative and not exclusive. The fact that AHA may have exercised any remedy without terminating this Contract shall not impair AHA's rights thereafter to terminate or to exercise any other remedy herein granted, or to which AHA may be otherwise entitled.

9.0 **Applicable Federal Law. ONLY PROJECTS USING FEDERAL FUNDS APPLIES.** Pursuant to 2 CFR 200 as issued by the Office of the Secretary, AHA and the Contractor each agree to comply with the following provisions:

- 9.1 **Executive Order 11246.** For all construction contracts awarded in excess of \$10,000, both parties hereby agree to comply with "Executive Order 11246 of September 24, 1965, entitled "Equal Employment Opportunity," as amended by Executive Order 11375 of October 13, 1967, and as supplemented in Department of Labor Regulations (41 CFR Chapter 60).
- 9.2 **Copeland "Anti-Kickback" Act.** For all construction or repair contracts awarded, both parties hereby agree to comply with the Copeland "Anti-Kickback" Act (18 U.S.C. 874) as supplemented in Department of Labor Regulations (29 CFR 10.27).
- 9.3 **Davis-Bacon Act. ONLY PROJECTS USING FEDERAL FUNDS APPLIES.** For all construction contracts awarded in excess of \$2,000 when required by Federal Grant Program legislation, both parties hereby agree to

comply with the Davis-Bacon Act (40 U.S.C. 276a to 276a-7) as supplemented in Department of Labor Regulations (29 CFR Part 5).

- 9.4 Sections 103 and 107 of the Contract Work Hours and Safety Standards Act.** For all construction contracts awarded in excess of \$2,000 and for other contracts, which involve the employment of mechanics or laborers awarded in excess of \$2,500, both parties hereby agree to comply with the Sections 103 and 107 of the Contract Work Hours and Safety Act (40 U.S.C. 327-330) as supplemented in Department of Labor Regulations (29 CFR Part 5).
- 9.5 Clean Air Act.** For all contracts in excess of \$100,000, both parties hereby agree to comply with all applicable standards, orders or requirements issued under Section 306 of the Clean Air Act (42 U.S.C. 1857(h), Section 508 of the Clean Water Act (33 U.S.C. 1368), Executive Order 11738, and Environmental Protection Agency regulations (40 CFR 49.3).
- 9.6 Energy Policy and Conservation Act.** Both parties hereby agree to comply with all mandatory standards and policies relating to energy efficiency, which are contained in the state energy conservation plan issued in compliance with the Energy Policy and Conservation Act (Pub. L. 94-163, 89 Stat. 871).
- 9.7 Additional Federally Required Orders/Directives. ONLY PROJECTS USING FEDERAL FUND APPLIES.** Both parties agree that they will comply with the following laws and directives, where applicable:
- 9.7.1 Executive Order 11061, ONLY PROJECTS USING FEDERAL FUNDS APPLIES.** as amended, which directs the Secretary of HUD to take all action which is necessary and appropriate to prevent discrimination by agencies that utilize federal funds.
- 9.7.2 Public Law 88-352, Title VI of the Civil Rights Act of 1964,** which provides that no person in the United States shall, on the basis of race, color, national origin or sex, be excluded from participation in, denied the benefits of, or subjected to discrimination under any program or activity which receives federal financial assistance. AHA hereby extends this requirement to the Contractor and its private contractors. Specific prohibited discriminatory actions and corrective action are described in Chapter 2, Subtitle C, Title V of the Anti-Drug Abuse Act of 1988 (42 U.S.C. 19901 et. seq.).
- 9.7.3 Public Law 90-284, Title VIII of the Civil Rights Act of 1968,** popularly known as the Fair Housing Act, which provides for fair housing throughout the United States and prohibits any person from discriminating in the sale or rental of housing, the financing of housing or the provision of brokerage services, including in any way making unavailable or denying a dwelling to

any person because of race, color, religion, sex or national origin. Pursuant to this statute, AHA requires that the Contractor administer all programs and activities, which are related to housing and community development in such a manner as to affirmatively further fair housing.

- 9.7.4 The Age Discrimination Act of 1975, which prohibits discrimination on the basis of age.
- 9.7.5 Anti-Drug Abuse Act of 1988 (42 U.S.C. 11901 et. seq.).
- 9.7.6 HUD Information Bulletin 909-23 which is the following: **ONLY PROJECTS USING FEDERAL FUNDS APPLIES.**
- 9.7.6.1 Notice of Assistance Regarding Patent and Copyright Infringement;
- 9.7.6.2 Clean Air and Water Certification; and
- 9.7.6.3 Energy Policy and Conservation Act.
- 9.7.7 That the funds that are provided by AHA and HUD hereunder shall not be used, directly or indirectly, to employ, award a Contract to, or otherwise engage the services of any debarred, suspended or ineligible Contractor.
- 9.7.8 That none of the personnel who are employed in the administration of the work required by this Contract shall, in any way or to any extent, be engaged in the conduct of political activities in violation of Title V, Chapter 15, of the United States Code.
- 9.7.9 That neither party has colluded, conspired, connived or agreed, directly or indirectly, with any bidder or person, to put in a sham bid or to refrain from bidding, and has not in any manner, directly or indirectly, sought by agreement or collusion, or communication or conference, with any person, to fix the bid price of affiant or of any other bidder, to fix overhead, profit or cost element of said bid price, or that of any other bidder, or to secure any advantage against either party or any person interested in the proposed Contract; and that all statements in said proposal or bid are true.
- 9.8 **Rights in Data and Patent Rights (Ownership and Proprietary Interest).** AHA shall have exclusive ownership of, all proprietary interest in, and the right to full and exclusive possession of all information, materials, and documents discovered or produced by Contractor pursuant to the terms of this Contract, including but not limited to reports, memoranda or letters concerning the research and reporting tasks of this Contract.

10.0 Lobbying Certification. ONLY PROJECTS USING FEDERAL FUNDS APPLIES

By execution of this Contract with AHA the Contractor thereby certifies, to the best of his or her knowledge and belief, that:

- 10.1** No federal appropriated funds have been paid or will be paid, by or on behalf of the undersigned, to any person for influencing or attempting to influence an officer or employee of an agency, a Member of Congress, an officer or employee of Congress, or an employee of a Member of Congress in connection with the awarding of any federal contract, the making of any federal loan, the entering into of any cooperative agreement, or modification of any federal contract, grant, loan, or cooperative agreement.
- 10.2** If any funds other than federal appropriated funds have been paid or will be paid to any person for influencing or attempting to influence an officer or employee of an agency, a Member of Congress, an officer or employee of Congress, or an employee of a Member of Congress in connection with this federal contract, grant, loan, or cooperative agreement, the Contractor shall complete and submit Standard Form – LLL, Disclosure Form to Report Lobbying, in an accordance with its instructions.
- 10.3** The Contractor shall require that the language of this certification be included in the award documents for all sub-awards at all tiers (including subcontracts, sub-grants, and contracts under grants, loans, and cooperative agreements) and that all sub-recipients shall certify and disclose accordingly.

11.0 Miscellaneous Provisions

- 11.1 Notices, Invoices and Reports.** Except as otherwise provided in this Contract, all notices, reports, records or other communications that are required or permitted to be given to the parties under this Contract shall be sufficient in all respects if given in writing and delivered in person, by email, facsimile, by overnight courier or by registered or certified mail, postage prepaid, return receipt requested, to the receiving party at the following address:

If to AHA: Gerald Cichon, Chief Executive Officer
AHA
5300 East Paisano Drive
El Paso, TX 79905-2931
Facsimile: 915-849-3868

If to Contractor: XXXXXX

RFP OPS 18 XXXXXXXX
XXXXXXXXXXXXXXXX

El Paso, TX 799XX

Phone number: XXX-XXX-XXXX

or such other address as such party may have given to the other parties by notice pursuant to this Section. Notice shall be deemed given on (i) the date such notice is personally delivered, (ii) three (3) days after the mailing if sent by certified or registered mail, (iii) one (1) business day after the date of delivery to the overnight courier if sent by overnight courier, or (iv) the next succeeding business day after transmission by facsimile, provided that any fax delivery is followed up with another method of notice listed in this Section within one (1) business day of sending the facsimile.

- 11.2 Taxes.** All persons doing business with AHA are hereby made aware that AHA is non-exempt from paying Texas State Sales and Use Taxes and Federal Excise Taxes.
- 11.3 Officials, Agents and Employees of AHA Not Personally Liable.** It is agreed by and between the parties hereto that in no event shall any official, officer, employee, or agent of AHA in any way be personally liable or responsible for any covenant or agreement herein contained whether expressed or implied, nor for any statement, representation or warranty made herein or in any connection with this Contract.
- 11.4 Assignment.** The Contractor shall not assign or transfer any interest in this Contract.
- 11.5 Entire Agreement; Amendment.** This Contract (including all Appendices attached hereto or other documents included by reference herein) constitutes the entire contract between the parties hereto and may not be modified except by an instrument in writing signed by the party to be charged. This Contract may be amended, supplemented or modified only by a written instrument duly executed by or on behalf of each party hereto.
- 11.6 Governing Law; Venue.** The laws of the State of Texas shall govern the validity, construction and effect of this Contract, unless such laws are superseded by, or in conflict with applicable federal laws and/or federal regulations. Each party irrevocably submits to the exclusive jurisdiction of any federal or state court located in El Paso County, Texas in any action, suit or proceeding arising out of or relating to this Contract, and agrees that any such action, suit or proceeding shall be brought only in such court.
- 11.7 Attorney's Fees.** In the event that litigation is commenced by one party hereto against the other in connection with the enforcement of any provision of this Contract, the prevailing party shall be paid by the losing party all

court costs and other expenses of such litigation, including reasonable attorneys' fees. The amount so allowed as attorneys' fees shall be taxed to the losing party as costs of the suit, unless prohibited by law.

- 11.8 Severability.** If any provision of this Contract or any portion or provision hereof applicable to any particular situation or circumstance is held invalid, the remainder of this Contract or the remainder of such provision (as the case may be), and the application thereof to other situations or circumstances shall not be affected thereby.
- 11.9 Waiver of Breach.** A waiver of either party of any terms or conditions of this Contract in any instance shall not be deemed or construed as a waiver of such term or condition for the future, or of any subsequent breach thereof. All remedies, rights, undertakings, obligations, and agreements contained in this Contract shall be cumulative and none of them shall limit any other remedy, right, obligation or agreement of either party.
- 11.10 Time of the Essence.** Time is of the essence for performance of this Contract.
- 11.11 Payment and Performance Bonds.** If the Contract Value as provided in Section 1.6.4 and 1.6.5, exceeds \$100,000, the Contractor shall furnish bonds covering faithful performance of the Contract and payment obligations arising thereunder. Bonds may be obtained through the Contractor's usual source and the cost thereof shall be included in the Contract Value. The amount of each bond shall be equal to one hundred percent (100%) of the Contract Value. In addition:
- 11.11.1**The bond must be approved and reviewed by AHA Procurement Manager;
 - 11.11.2**The bond must name AHA as obligee;
 - 11.11.3**The Contractor shall deliver the required bonds to AHA before the commencement of any work pursuant to this Contract.
- 11.12 Limitation of Liability.** In no event shall AHA be liable to the Contractor for any indirect, incidental, consequential or exemplary damages.

[SIGNATURES APPEAR ON FOLLOWING PAGE]

12.0 Certifications. The undersigned representatives of each party acknowledge by signature below that they have reviewed the foregoing and understand their respective obligations as defined herein. This Contract may be signed in counterparts.

**AFFORDABLE HOUSING ACQUISITION AN AFFILIATE OF
THE HOUSING AUTHORITY OF THE CITY OF EL PASO**

By _____ Date _____
: _____ : _____
GERALD CICHON
CHIEF EXECUTIVE OFFICER

XXXXXXXXXXXXXXXX

By _____ Date _____
: _____ : _____
AUTHORIZED SIGNER
TITLE

**AFFORDABLE HOUSING ACQUISITION AN AFFILIATE OF
THE HOUSING AUTHORITY OF THE CITY OF EL PASO
APPROVED AS TO FORM ONLY:**

By _____ Date _____
: _____ : _____
AHA LEGAL COUNSEL

AFFORDABLE HOUSING ACQUISITION

RFP OPS 18-R-0022

Remodeling and Renovation of 300 units at
Villa Alegre Apartments

Attachment B

Attachment B

**PLAN A- 1 BR/ 1 BA
457 SF**

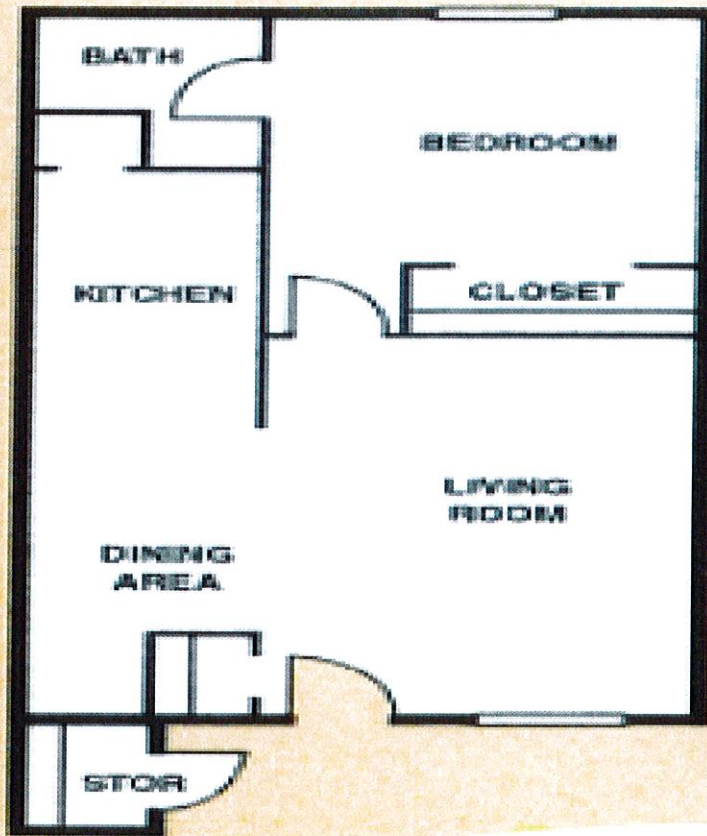

PLAN B- 2 BR/ 2 BA
962 SF

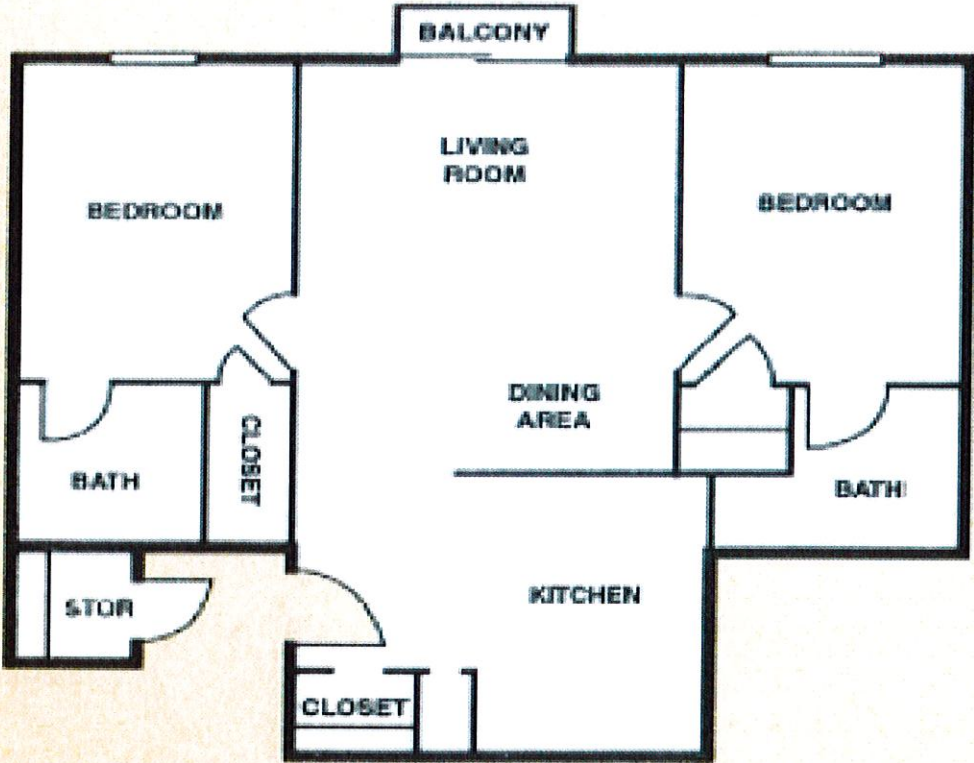

PLAN C- 1 BR/ 1 BA
633 SF

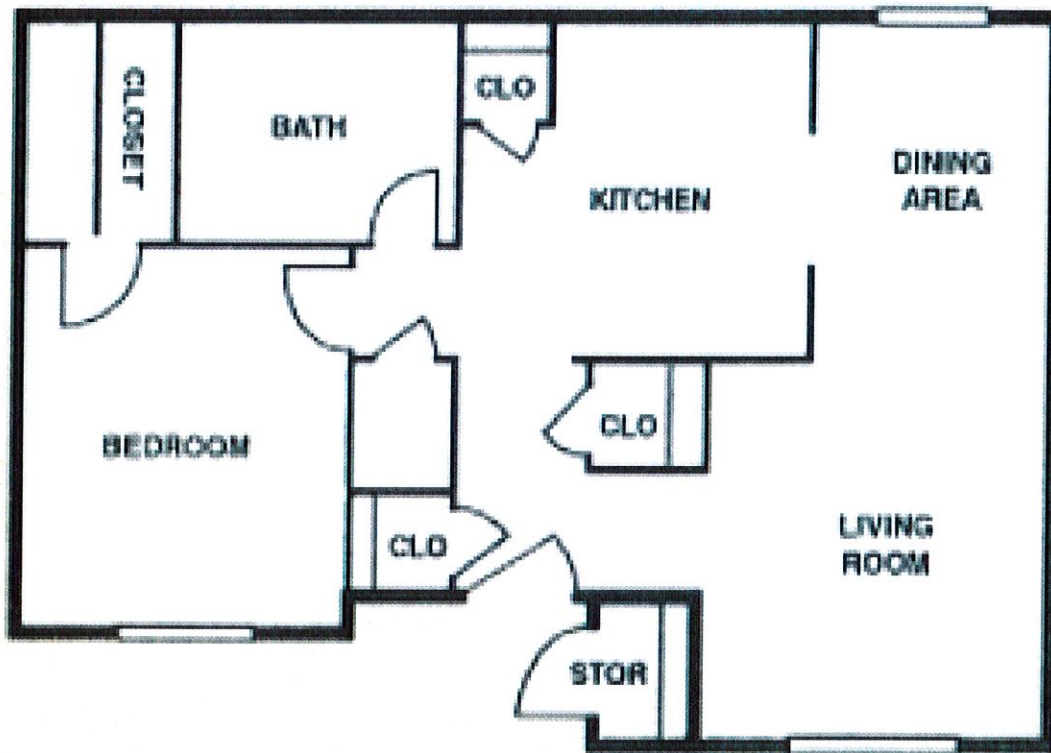

PLAN D- 2 BR/ 1 BA
787 SF

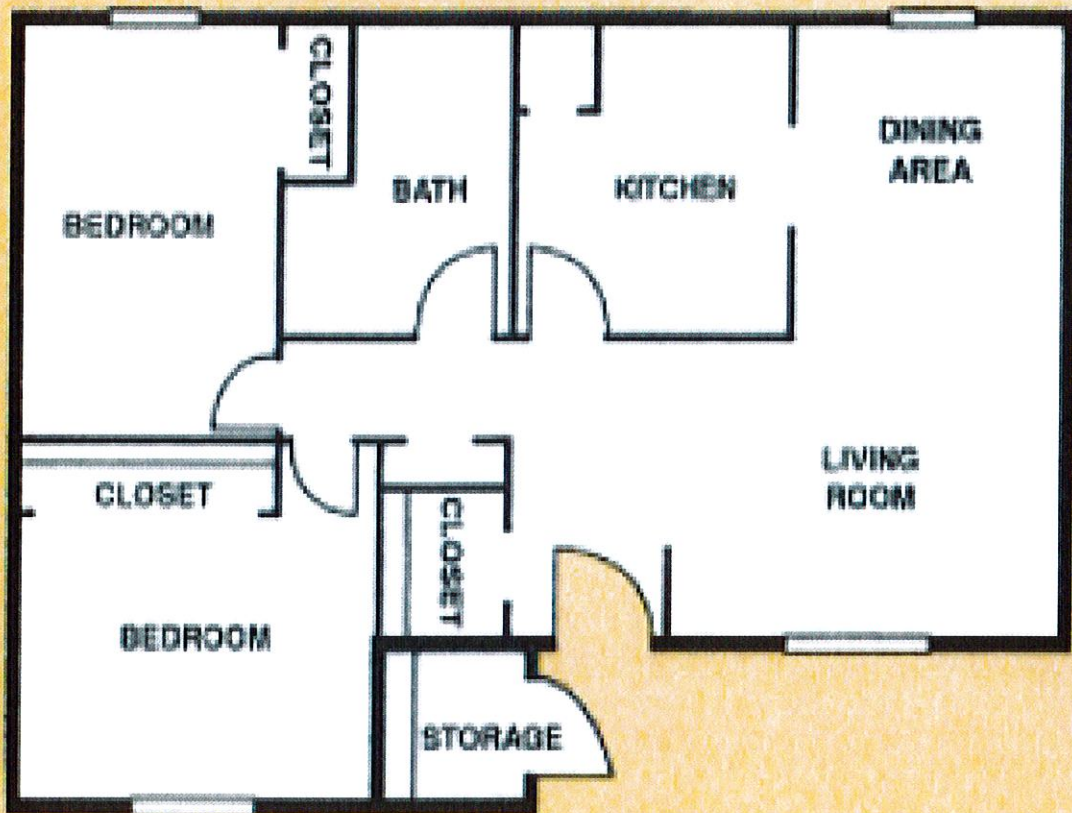

PLAN E- 3 BR/ 2 BA 1025 SF

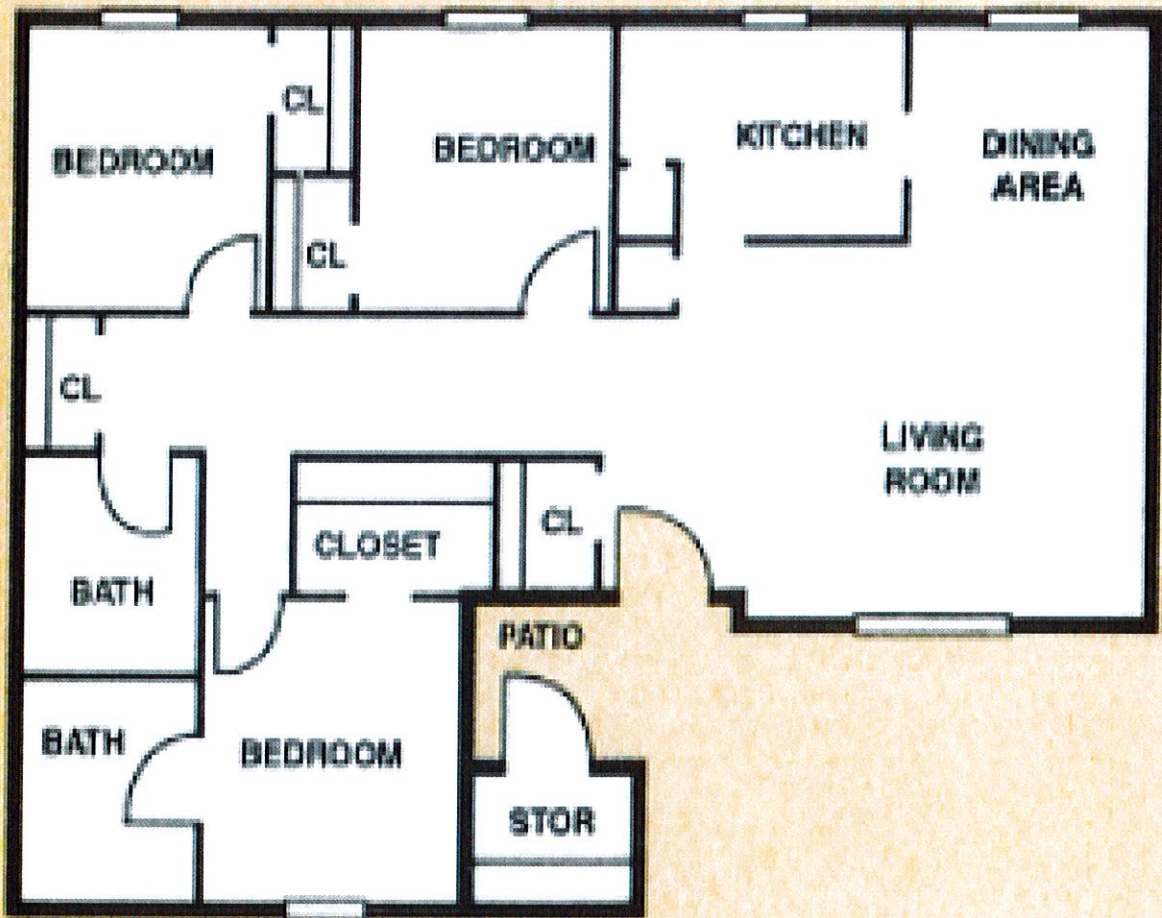

**PLAN F- 2 BR/ 1½ BA
914 SF**

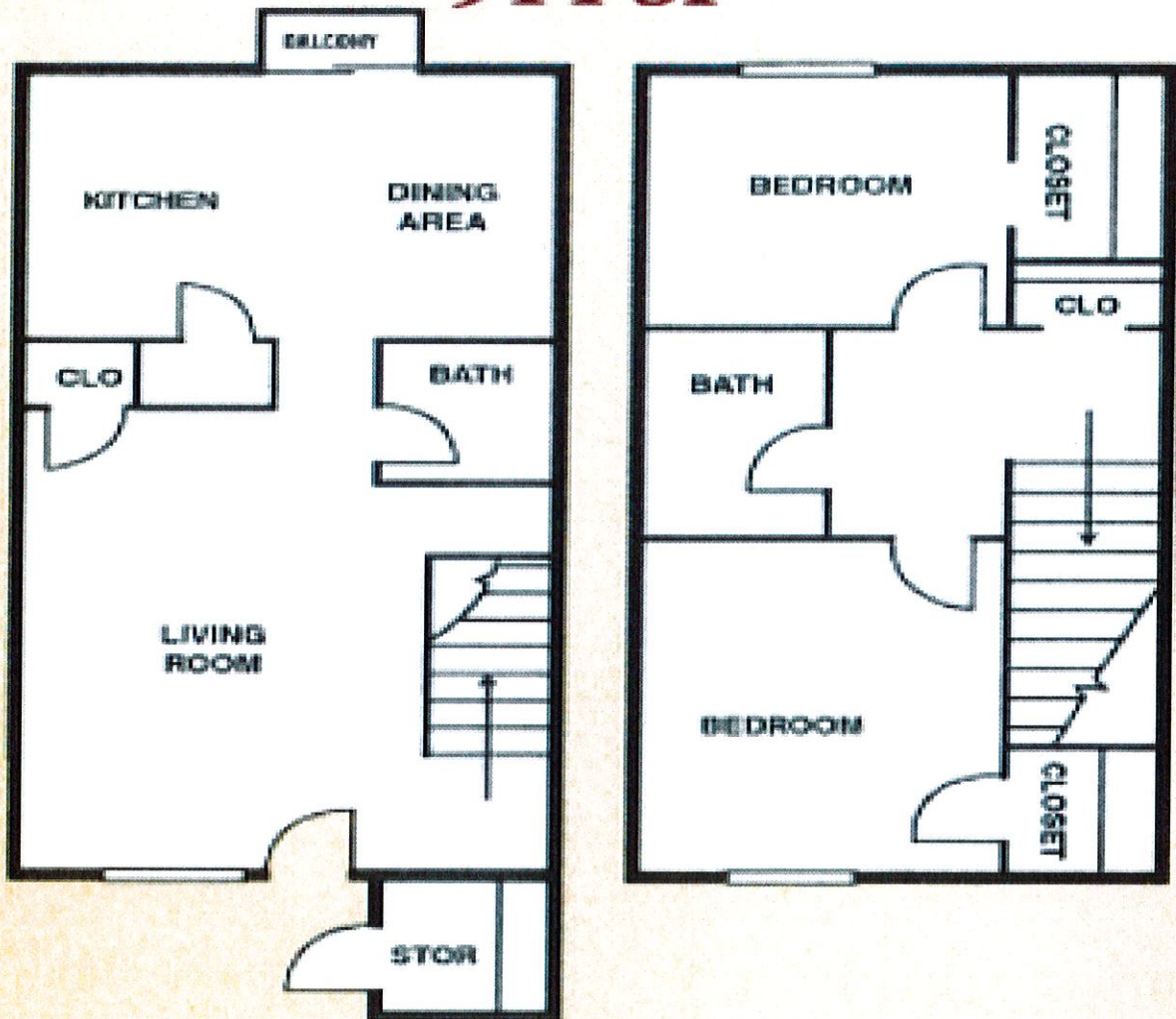

AFFORDABLE HOUSING ACQUISITION

RFP OPS 18-R-0022

Remodeling and Renovation of 300 units at
Villa Alegre Apartments

Attachment C

GE® ENERGY STAR® 17.5 Cu. Ft. Top-Freezer Refrigerator



Model# GTE18GTHWW



FEATURES

Temperature Management Features	Air Tower
Defrost Type	Frost Free
Control Type	Upfront Temperature Controls
Icemaker	Optional (IM4D Ready)
Fresh Food Cabinet Shelves	1 Glass Drawer Cover; 2 Adjustable; 2 Full-Width; 2 Glass; 2 Spill Proof; 3 Total
Fresh Food Door Shelves	3 Fixed (2 with Gal. Storage)
Fresh Food Cabinet Drawers	1 Snack Drawer; 2 Adjustable Humidity Drawers; 3 Total Clear
Fresh Food Door Features	Dairy Compartment; Gallon Storage
Freezer Cabinet Shelves	1 Adjustable Wire
Freezer Door Shelves	2 Fixed
Freezer Features	Spillproof Freezer Floor
Exterior Style	Free-Standing
Leveling System	2 Point Front Adjustable
Performance Features	Easily Removable Door Gaskets; Never Clean Condenser

- #1 in Quality and Dependability - Among 14-18 cu. ft. refrigerators based on an independent study of property maintenance personnel. Source: The Stevenson Company, 2016—Market research company with over 20 years of experience in the appliance industry
- Upfront temperature controls - Easy-to-use controls regulate both fresh food and freezer sections
- Adjustable spillproof glass shelves - Hold up to 12 oz. of spilled liquids for easy cleanup and adjust to provide additional food-storage options
- Equipped for optional icemaker - Easily accommodates the installation of an icemaker
- Snack drawer - Conveniently stores favorite foods and allows for quick, easy access
- Adjustable-humidity drawers - Controls helps food stay fresh
- Large door storage - Offers ideal space for storing large containers in the door, freeing up valuable shelf space
- Can storage door shelf - Holds cans in the door for easy selection and quick access
- Adjustable wire freezer shelf - Easily adjusts between two positions to accommodate items of all shapes and sizes
- Spillproof freezer floor - Seamless design of the freezer floor wipes up easily for quick cleanup
- Quick door reversal - Easily adjust refrigerator and freezer doors to swing from the left or the right side.

Have more questions? Please contact 1-800-626-2005

GE® ENERGY STAR® 17.5 Cu. Ft. Top-Freezer Refrigerator



Model# GTE18GTHWW

APPROXIMATE DIMENSIONS (HxDxW)

- 67 3/8 in x 32 1/2 in x 28 in

CAPACITY

- Total Capacity (cubic feet) 17.50 cu ft
- Fresh Food Capacity 13.50 cu ft
- Freezer Capacity 4 cu ft

WARRANTY

- Parts Warranty - Limited 1-year entire appliance
- Labor Warranty - Limited 1-year entire appliance
- Warranty Notes - See written warranty for full details

Have more questions? Please contact 1-800-626-2005

FFHT2021T S/W/B

TOP MOUNT
REFRIGERATOR
20.4 CU. FT. TOP MOUNT



AVAILABLE COLORS



Stainless



White



Black

PRODUCT DIMENSIONS

Height (Including Hinges & Rollers)	69"
Width	30"
Depth (Including Door)	31-3/4"

MORE EASY-TO-USE FEATURES

Reversible Door

Door can be installed to open left or right based on your needs.

Clear Dairy Bin

Keep foods like butter, cheese and yogurt organized.

CERTIFICATIONS

ENERGY STAR®



¹Compared to 18 cu. ft. top mount refrigerators.

SIGNATURE FEATURES

Same Width. More Capacity.¹

With a 20 cu.ft. top freezer refrigerator, you can have a refrigerator that fits the same space as an 18 cu.ft. top freezer refrigerator, but get more capacity.

Store-More™ Humidity-Controlled Crisper Drawers

Keep your fruits and vegetables fresh in our humidity-controlled crisper drawers.

Store-More™ Gallon Door Shelf

Door storage gives you room for larger items like a gallon of milk.

Full-Width Wire Freezer Shelf

Gives you a way to organize items in your freezer better so you can find food quickly.

FFHT2021T S/W/B TOP MOUNT REFRIGERATOR

FRIGIDAIRE

20.4 CU. FT.

FEATURES

Door Design	UltraSoft™
Door Handle Design	Stainless Steel (S), Color-Coordinated (W/B)
Cabinet Finish (Textured)	Black (S), Color-Coordinated (W/B)
Door Stops	Yes
Door Hinge Covers	Black (S), Color-Coordinated (W/B)
Door Reverse Option	Yes
Rollers - Front/Rear	Adjustable/Yes
Sound Package	
Toe Grille	Black (S), Color-Coordinated (W/B)

REFRIGERATOR FEATURES

Interior Lighting	Bright
Refrigerator Shelves	2 Full-Width Glass
Deli Drawer	1 Half-Width
Wine/Can Rack	
Store-More™ Crisper Drawers	2 Clear
Humidity Controls	2
Dairy Compartment	Clear Dairy Door
Door Bins	
Door Racks	3 Full-Width White
Non-Slip Bin Liner	
Tall Bottle Retainers	
Gallon Door Storage	1

FREEZER FEATURES

Door Bins	
Door Racks	2 Full-Width White
Freezer Shelves	1 Full-Width Wire
Factory Ice Maker w/ Large Ice Bin	Optional (PN# IM116)
Lighting	

CERTIFICATIONS

ENERGY STAR®	Yes
--------------	-----

SPECIFICATIONS

Total Capacity (Cu. Ft.)	20.4
Refrigerator Capacity (Cu. Ft.)	15.3
Freezer Capacity (Cu. Ft.)	5.1
Power Supply Connection Location	Right Bottom Rear
Water Inlet Connection Location	Bottom Right
Voltage Rating	120V / 60Hz
Connected Load (kW Rating) @ 120 Volts ¹	0.72
Amps @ 120 Volts	6.0
Minimum Circuit Required (Amps)	15
Shipping Weight (Approx.)	220 Lbs.

¹For use on adequately wired 120V, dedicated circuit having 2-wire service with a separate ground wire. Appliance must be grounded for safe operation.

PRODUCT DIMENSIONS

A - Height (Including Hinges & Rollers)	69"
B - Width	30"
C - Depth (Including Door)	31-3/4"
Depth with Door Open 90°	60"

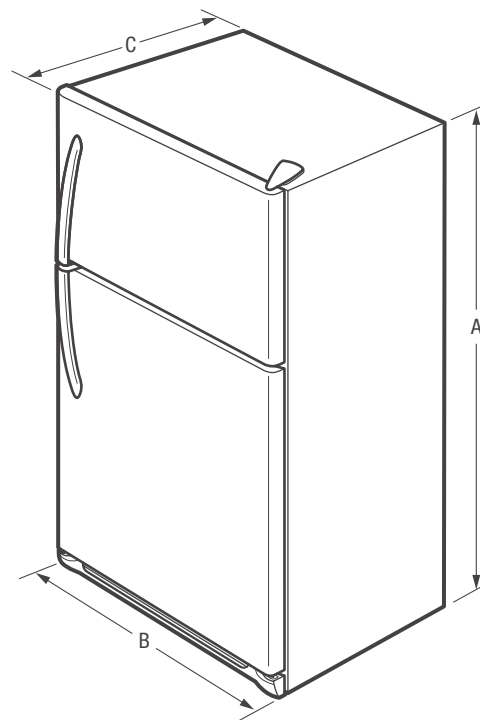

Note: For planning purposes only. Always consult local and national electric, gas and plumbing codes. Refer to Product Installation Guide for detailed installation instructions on the web at frigidaire.com.

Specifications subject to change. Accessories information available on the web at frigidaire.com

FRIGIDAIRE

USA • 10200 David Taylor Drive • Charlotte, NC 28262 • 1-800-FRIGIDAIRE • frigidaire.com
CANADA • 5855 Terry Fox Way • Mississauga, ON L5V 3E4 • 1-800-265-8352 • frigidaire.ca

FFHT2021T 10/17
© 2017 Electrolux Home Products, Inc.

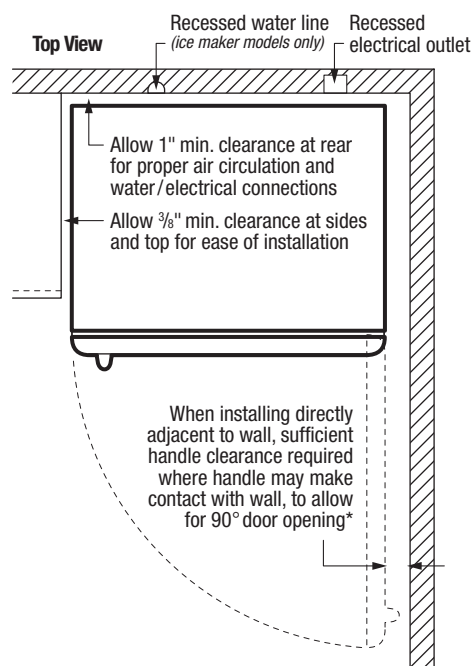

* When installing refrigerator adjacent to wall, cabinet or other appliance that extends beyond front edge of unit, 20" minimum clearance recommended to allow for optimum 140° door swing, providing complete crisper access and removal. (Absolute 3" minimum clearance will ONLY allow for 90° door swing which will provide limited crisper access with restricted removal.)

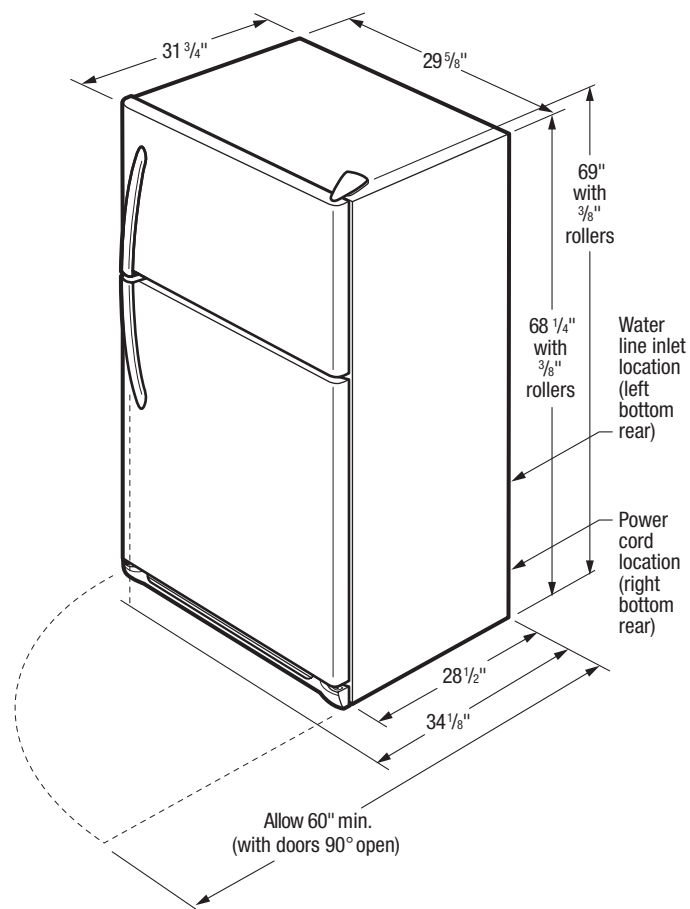

INSTALLATION SPECIFICATIONS

- Product Shipping Weight (approx.) - 220 Lbs.
- An electrical supply with grounded three-prong receptacle is required. The power supply circuit must be installed in accordance with current edition of National Electrical Code (NFPA 70) and local codes & ordinances.
- Voltage Rating - 120V / 60 Hz
- Connected Load (kW Rating) @ 120 Volts = 0.72kW
- Amps @ 120 Volts = 6.0 Amps
- Always consult local and national electric & plumbing codes.
- Floor should be level surface of hard material, capable of supporting fully loaded refrigerator.
- Minimum 3/8" clearance required for sides and top of refrigerator with 1" clearance at rear to allow for ease of installation, proper air circulation, and plumbing/electrical connections.
- When installing refrigerator adjacent to wall, cabinet or other appliance that extends beyond front edge of unit, 20" minimum clearance recommended to allow for optimum 140° door swing, providing complete crisper access and removal. (Absolute 3" minimum clearance will ONLY allow for 90° door swing which will provide limited crisper access with restricted removal.)
- To ensure optimum performance, do not install in areas where temperature drops below 55°F or rises above 110°F and avoid installing in direct sunlight or close proximity to range, dishwasher or other heat source.
- For proper ventilation, front grille MUST remain unobstructed.
- Recess electrical outlet when possible.
- Optional Ice Maker Kit (PN# IM116) available for installation in ice maker-ready models only.
- Water recess on rear wall recommended to prevent water line damage.
- Water Pressure - Cold water line must provide between 30 and 100 pounds per square inch (psi).
- Copper tubing with 1/4" O.D. recommended for water supply line with length equal to distance from rear of unit to household water supply line plus 7 additional feet. Optional Water Supply Installation Kits available.
- Adjustable front rollers to assist with door alignment.

OPTIONAL ACCESSORIES

- Ice Maker Kit - (PN# IM116).



PFWSC1340G Series

Two Handle Lavatory Faucet



Product Features

- Ceramic Cartridges
- Metal Lever Handles
- Max. flow rate: 1.2 GPM (PFWSC1340GCP)
- Max. flow rate: 0.5 GPM (PFWSC13405GCP)
- With Brass Grid Drain
- EPA WaterSense approved (PFWSC1340GCP)
- Meets ANSI: A112.18.1M
- NSF-61 compliant
- ADA Compliant



PFWSC1340GCP

Model Numbers

- PFWSC1340GCP-1.2 GP M Polished chrome
- PFWSC13405GCP-0.5 GPM Polished chrome

Product Specifications

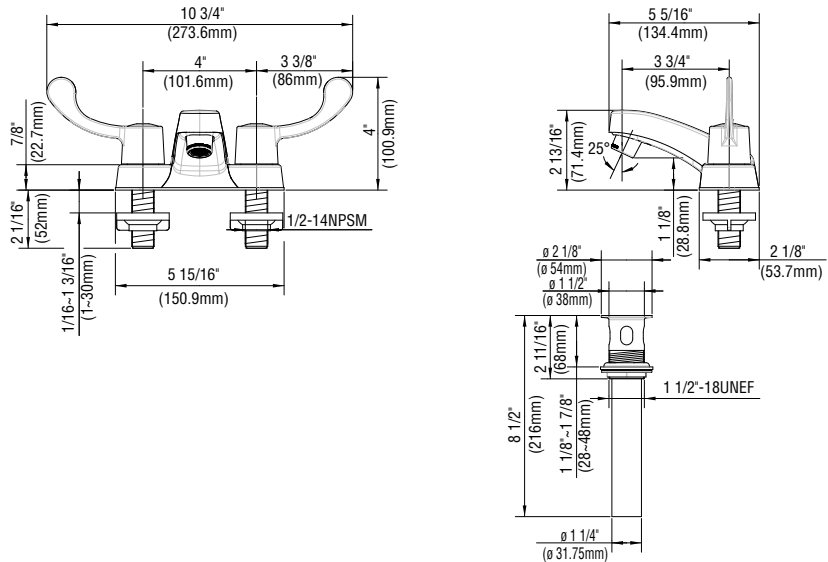

Warranty and Codes

This product comes complete with installation, operating, care and maintenance instructions. This PROFLO faucet carries a limited lifetime warranty when installed in residential applications.

The warranty is five years in commercial applications.

This product meets ANSI: A112.18.1M.

Compliant with lead content requirements of California AB 1953.



* All measurements are nominal. Please verify before actual installation.



Features

- Compression molded from our exclusive solid Vikrell® material.
- Modular design allows it to be moved around corners and through doorways with ease.
- Durable swirl gloss finish.
- Convenient shelving and acrylic towel bar on back wall.

Installation

- Caulk required in seams for proper installation.

Recommended Accessories

- 500C-59 Framed Sliding Bath Door
- 5905-57 Framed Sliding Bath Door
- 5905-59 Framed Sliding Bath Door
- 690B-59 Framed Sliding Bath Door
- 5325EZ-57 Frameless Sliding Bath Door
- 5906-59 Framed Sliding Bath Door
- 5425-57 Frameless Sliding Bath Door
- 5425-59 Frameless Sliding Bath Door
- 5907-59 Framed Sliding Bath Door
- 542808-59 Frameless Sliding Bath Door
- 5427-59 Frameless Sliding Bath Door
- 572005-59 Framed Sliding Bath Door
- 5900-57 Framed Sliding Bath Door
- 581005-59 Frameless Sliding Bath Door
- 80001012 12" Grab Bar
- 80001018 18" Grab Bar
- 80001024 24" Grab Bar
- 80011032 32" Grab Bar
- 80001036 36" Grab Bar
- VA-80172 Window Trim Kit



Codes/Standards

- CSA B45.5/IAPMO Z124
- ASTM E162
- ASTM E662
- Greenguard UL 2818 - Gold

Warranty – Bathing Fixtures (and) Kitchen and Utility Sinks Made of Solid Vikrell® Material

See website for detailed warranty information.

Available Color/Finishes

Color tiles intended for reference only.

Color	Code	Description
	0	White
	96	KOHLER Biscuit



All Pro®
60" Bath/Shower Wall Set
61044100

No image available.
This product is a component and not intended to be a standalone installation.

Technical Information

All product dimensions are nominal.

Installation: 3-Wall Alcove

Notes

Install this product according to the installation instructions.

Amana® Undercounter Dishwasher

PRODUCT MODEL NUMBERS

ADB1400PY ADB1300AF ADB1400AG
 ADB1500AD ADB1100AW

Electrical Requirements: 120-volt, 60 Hz, AC-only, 15- or 20-amp. fused electrical supply. Copper wire only. A time delay fuse or circuit breaker and separate circuit is recommended.

If direct wiring dishwasher: Use flexible, armored or nonmetallic, sheathed copper wire with grounding wire that meets the wiring requirements for your home and local codes and ordinances. Use a UL Listed or CSA Approved conduit connector.



If connecting dishwasher with a power supply cord: Use power supply cord kit (Part Number 4317824) marked for use with dishwashers. Follow the kit instructions for installing the power supply cord.

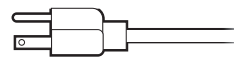

Power supply cord must plug into a grounded 3 prong outlet located in the cabinet next to the dishwasher opening. Outlet must meet all local codes and ordinances.

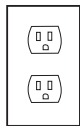

Water Supply Requirements: A hot water line with 20 to 120 psi (138 to 862 kPa) water pressure. Water temperature must be 120°F (49°C) water at dishwasher. Use 3/8" O.D. copper tubing with compression fitting or flexible braided water supply line

Note: 1/2" minimum plastic tubing is not recommended. Use a 90° elbow with 3/4" hose connection with rubber washer (part number W10273460). Do not solder within 6" (15.2 cm) from water inlet valve.

Drain Requirements: A new drain hose is supplied with your dishwasher. If this is not long enough, use a new drain hose with a maximum length of 12' (3.7 m) (Part No. 3385556) that meets all current AHAM/IAPMO test standards, is resistant to heat and detergent, and fits the 1" (2.5 cm) drain connector of the dishwasher.

Make sure to connect the drain hose to waste tee or disposer inlet above drain trap in house plumbing and 20" (50.8 cm) minimum above the floor. It is recommended

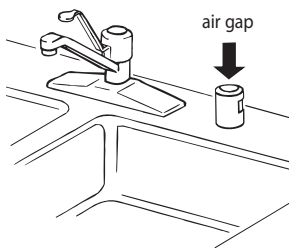

that the drain hose either be looped up and securely fastened to the underside of the counter, or be connected to an air gap.

Make sure to use an air gap if the drain hose is connected to house plumbing lower than 20" (50.8 cm) above subfloor or floor.

Use 1/2" (1.3 cm) minimum I.D. drain line fittings.

If required, the air gap should be installed in accordance with the air gap installation instructions. When connecting the air gap a rubber hose (not provided) will be needed to connect to the waste tee or disposer inlet.

PRODUCT DIMENSIONS

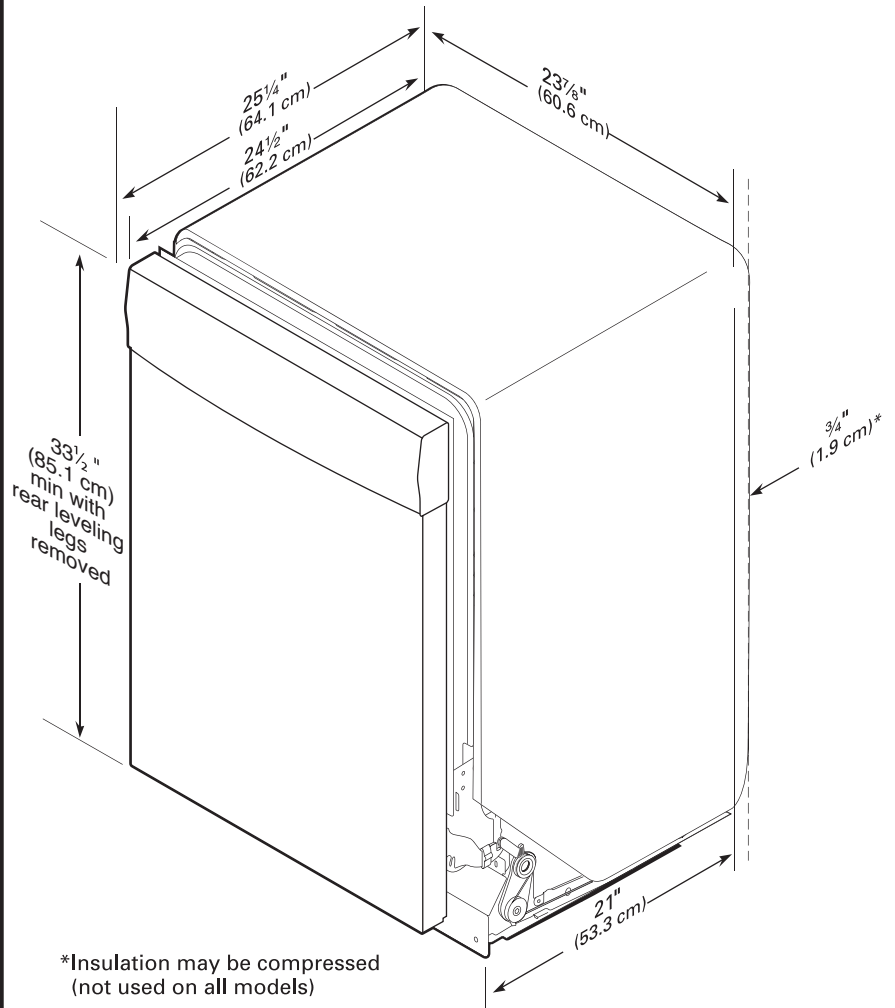

CABINET CUTOUT DIMENSIONS

NOTE: Shaded areas of cabinet walls show where utility connections may be installed.

*Measure from the lowest point on the underside of the countertop. May be reduced to 33½" (85.1 cm) by removing the rear leveling legs from dishwasher.

**Minimum, measured from narrowest point of opening.

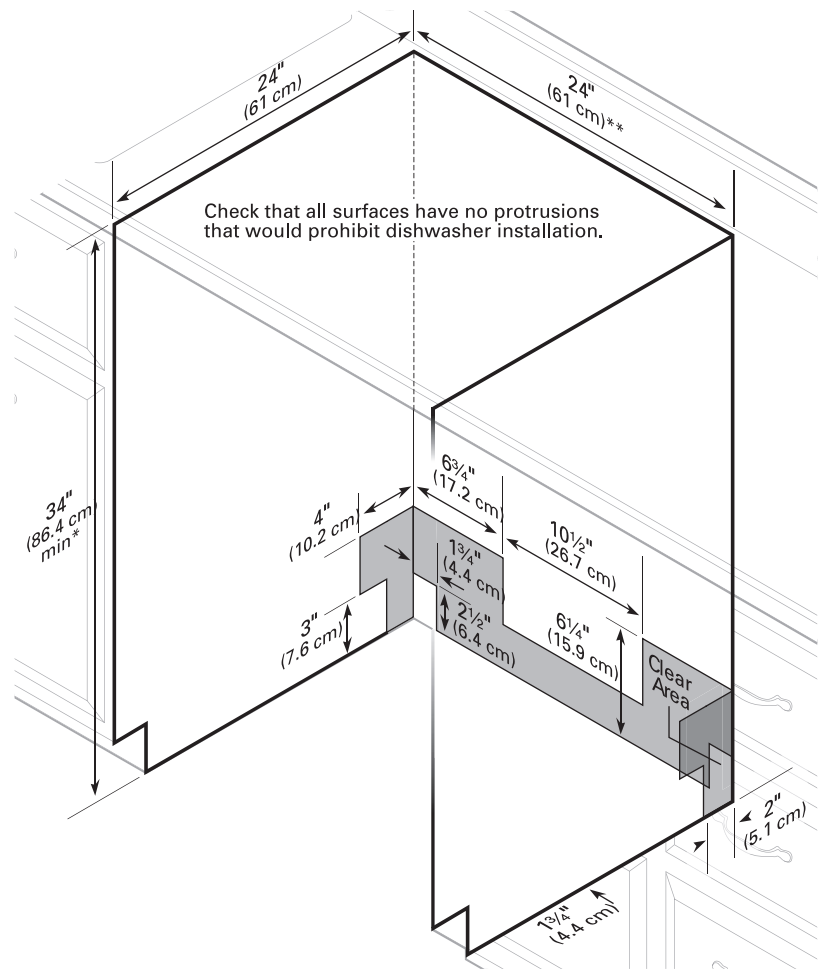

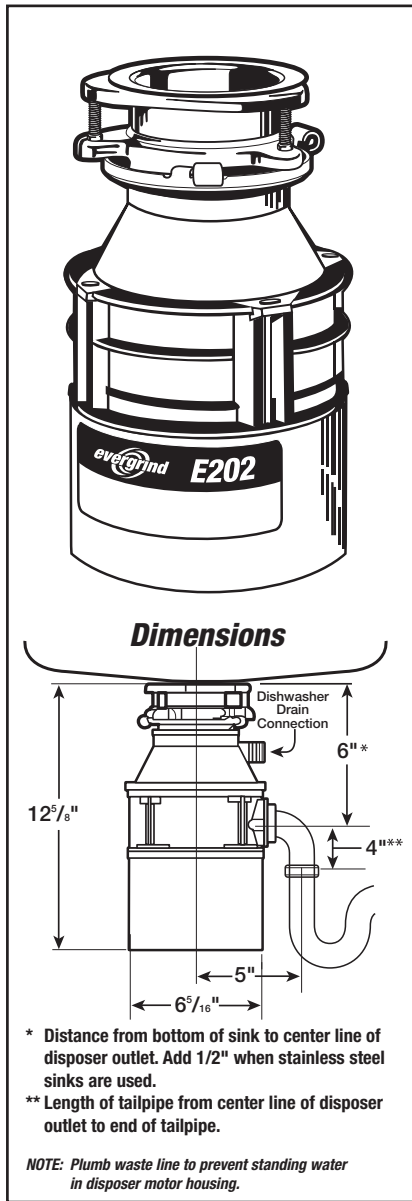

Model E202 Food Waste Disposer

Submittal Sheet

- 1 year parts and in-home service warranty†
- Quick Lock® mounting for fast, easy installation
- Galvanized steel grinding elements with two stainless steel 360° swivel lugs
- Stainless steel sink flange with positive seal plastic stopper
- Overload protector manual reset
- Permanently lubricated upper and lower bearings
- Cushioned anti-splash baffle
- Dishwasher drain connection
- Exclusive self-service wrench

Sample Specification

Food Waste Disposer(s) shall be Evergrind™ Model E202, continuous feed, with 1/2 H.P. motor, galvanized steel grinding elements with two stainless steel 360° swivel lugs. Self-service wrench.

Warranty - 1 year parts and in-home service.

† The complete Evergrind™ warranty is included in the Care & Use Booklet, packed with each unit.

Specifications

Type of Feed	Continuous
On/Off Control	Wall Switch
Motor	Single Phase
HP	1/2
Volts	120
HZ	60
RPM	1725
Amp. (Avg. Load)	6.3
Time Rating	Intermittent
Lubrication	Permanently Lubricated Upper & Lower Bearings
Shipping Weight (Approx.)	14 lbs. 2 oz.
Unit Finish	Waterborne Grey Enamel
Overall Height	12-5/8"
Grind Chamber Capacity	26 oz.
Motor Protection	Manual Reset Overload
Average Water Usage	Approx. 1 Gallon per Person Per Day
Average Electrical Usage	3-4 KWh per Year
Drain Connection	1-1/2" Cushioned Slip Joint
Dishwasher Drain Connection	Yes

Job Specifications

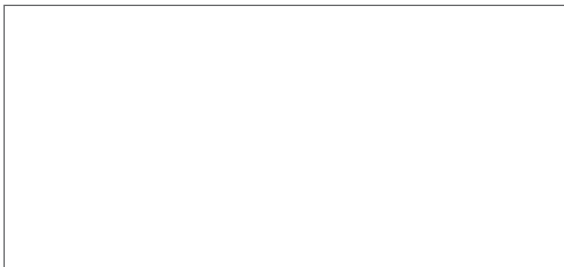

Food waste disposers can provide an environmentally responsible alternative to transporting food waste to landfills. And they can help reduce greenhouse gas emissions. At capable wastewater treatment plants, food waste can be recycled to produce renewable energy. Additionally, capable wastewater treatment plants can process food waste into fertilizer. (Check the plant in your area.)

www.insinkerator.com/green



EMERSON™
Commercial & Residential Solutions

The Emerson logo is a trademark and service mark of Emerson Electric Co. The mounting collar configuration is a trademark of Emerson Electric Co. Quick Lock® is a registered trademark of Emerson Electric Co.

InSinkErator may make improvements and/or changes in the specifications at any time, in its sole discretion, without notice or obligation and further reserves the right to change or discontinue models.

Plan-ID	Qty	Model No	Description	Page
AC-01	3	NXA424GKC	Condensing Unit 208/230-1 ph	3
	3	FEM4P2400AL	Air Handler 230v - 1ph	6
AC-02	2	NXA424GKC	Condensing Unit 208/230-1 ph	9
	2	FEM4P2400AL	Air Handler 230v - 1ph	12
AC-03	5	NXA424GKC	Condensing Unit 208/230-1 ph	15
	5	FEM4P2400AL	Air Handler 230v - 1ph	18
(8-2017) Limited Warranty Certificate for Residential Split System AC & HP (1 & 3-Phase)				21

AHRI Rated Cooling Performance

AHRI Certified Reference # 9487261
 AHRI Rated Cooling Capacity 22,800 Btuh
 EER 11.50 EER
 SEER 14 SEER
 Rated Indoor Coil: FEM4P2400AL

Cooling Performance @ Project Parameters

Net Cooling Capacity 21,529 Btuh
 Net Sensible Capacity 18,239 Btuh
 Net Latent Capacity 3,290 Btuh
 Total Supply Air 864 cfm
 Outdoor DB Temp 105.0 °F
 Entering DB Temp 80.0 °F
 Entering WB Temp 67.0 °F
 Leaving DB Temp 60.5 °F
 Leaving WB Temp 59.4 °F

Cooling derated for Altitude of 4000 feet

Electrical Data

Power Supply 208/230 Volts
 1 Phase
 60 Hertz
 Minimum Circuit Ampacity 14.1 Amps
 MOCP 20 Amps

Weight

Total Weight 119 lb

Field Installed Accessories

Features

Split System Air Conditioner

Refrigeration Circuit

- Scroll compressor
- Filter-Drier supplied
- Copper tube / aluminum fin coil

Easy to Install and Service

- Easy Access service valves
- External high and low refrigerant service ports
- Only two screws to access control panel
- Factory charged with R-410A refrigerant

Built to Last

- Baked-on powder coat finish over galvanized steel
- Post-painted (black) coil fins
- Coated Weather Resistant cabinet screws
- Coated inlet grille with 3/8" grille spacing

Warranty

- 5 year compressor limited warranty
- 5 year parts limited warranty (including compressor and coil)
- With timely registration, an additional 5 years. (including compressor and coil)
- Applies to original purchaser/homeowner, some limitations may apply. See warranty certificate for complete details.

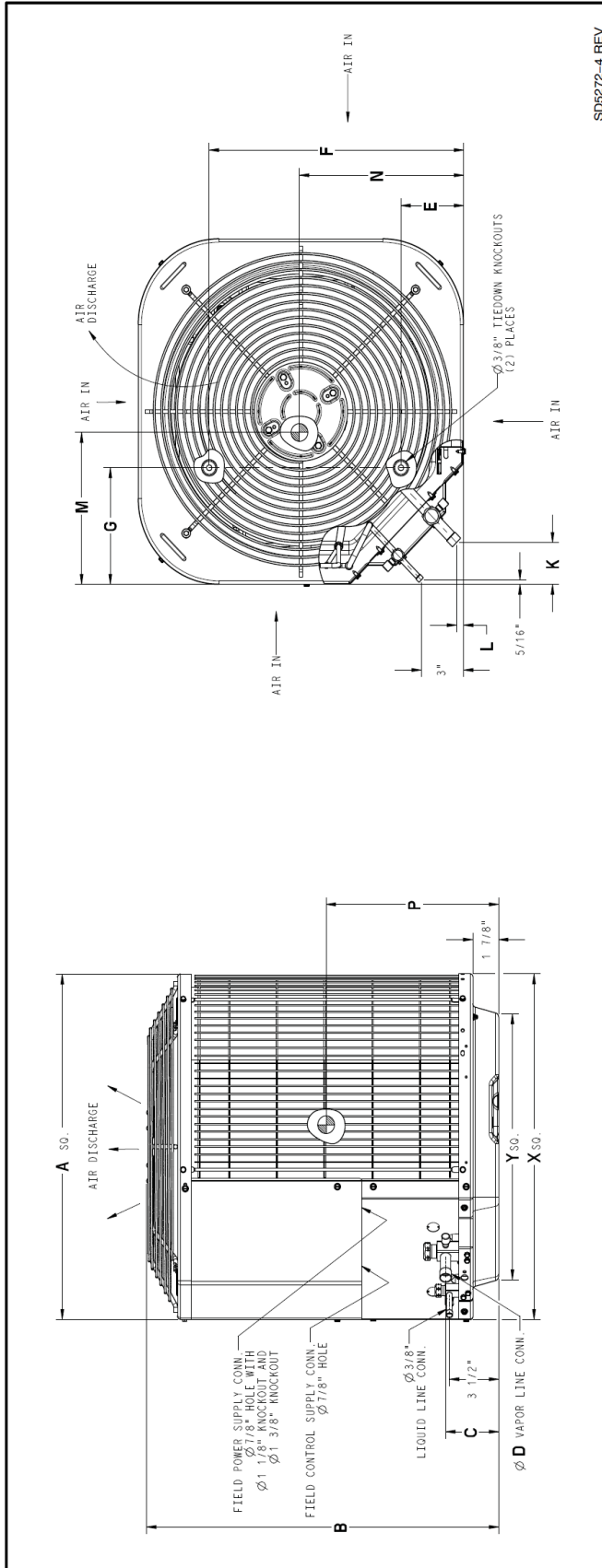

SD5272-4 REV

1. Allow 24" clearance to service side of unit, 48" above unit, 6" on one side, 12" on remaining sides.
2. Maintain a distance of 24" between units or 18" if no overhang within 12'.
3. Minimum outdoor operating ambient in cooling mode is 55°F, max 125°F.
4. Center of Gravity

Dimensions (in.)														
A	B	C	D	E	F	G	K	L	M	N	P	Crated Dimensions H x W x D		
25-3/4	25	3-3/4	3/4	4-7/16	21-1/4	9-1/8	2-13/16	1/2	13-5/8	12-1/8	9-7/8	25-3/4 x 25-3/4	20-7/16 x 20-7/16	27-7/8 x 27-7/8 x 32-9/16

Electric Resistance Heat

Model Number	EHK10AKN
Nominal Heat Size	10 kW
Electric Heat Voltage	230 Volts

Weight

Weight	112 lb
Electric Heat Weight	55 lb
Total Weight	167 lb

Supply Air Performance

Total Supply Air	864 cfm
External Static Pressure	0.30 in wg.
Blower Type	Direct Drive
Tap 5 Blower Speed	
Motor Rated HP	0.50 hp

Blower Performance corrected for Altitude of 4000 feet

Electrical Data

Power Supply	230 Volts
	1 Phase
	60 Hertz
Minimum Circuit Ampacity	58.5 Amps
MOCP	60 Amps

Field Installed Accessories

EHK10AKN - 10 kW

Features

FAN COIL

- Aluminum Tube, Aluminum Fin Evaporator
- Factory installed Piston with Teflon ring metering device
- Low voltage circuit protective fuse (3 amp) inline on wire harness
- Time Delay Relay (TDR)
- Sweat refrigerant connections
- Multiple electric entry location
- High efficiency ECM, 5-speed motor
- Units tested and certified by manufacturer to achieve 2% or less leakage rate at 1.0 inch water column
- 1 inch thick Insulation with R value of 4.2
- HUD approved for manufactured housing.

Warranty

- 1 year No Hassle Replacement™ limited warranty.
- 5 year parts limited warranty
- With timely registration, an additional 5 year parts limited warranty
- Applies to original purchaser/homeowner, some limitations may apply. See warranty certificate for complete details.

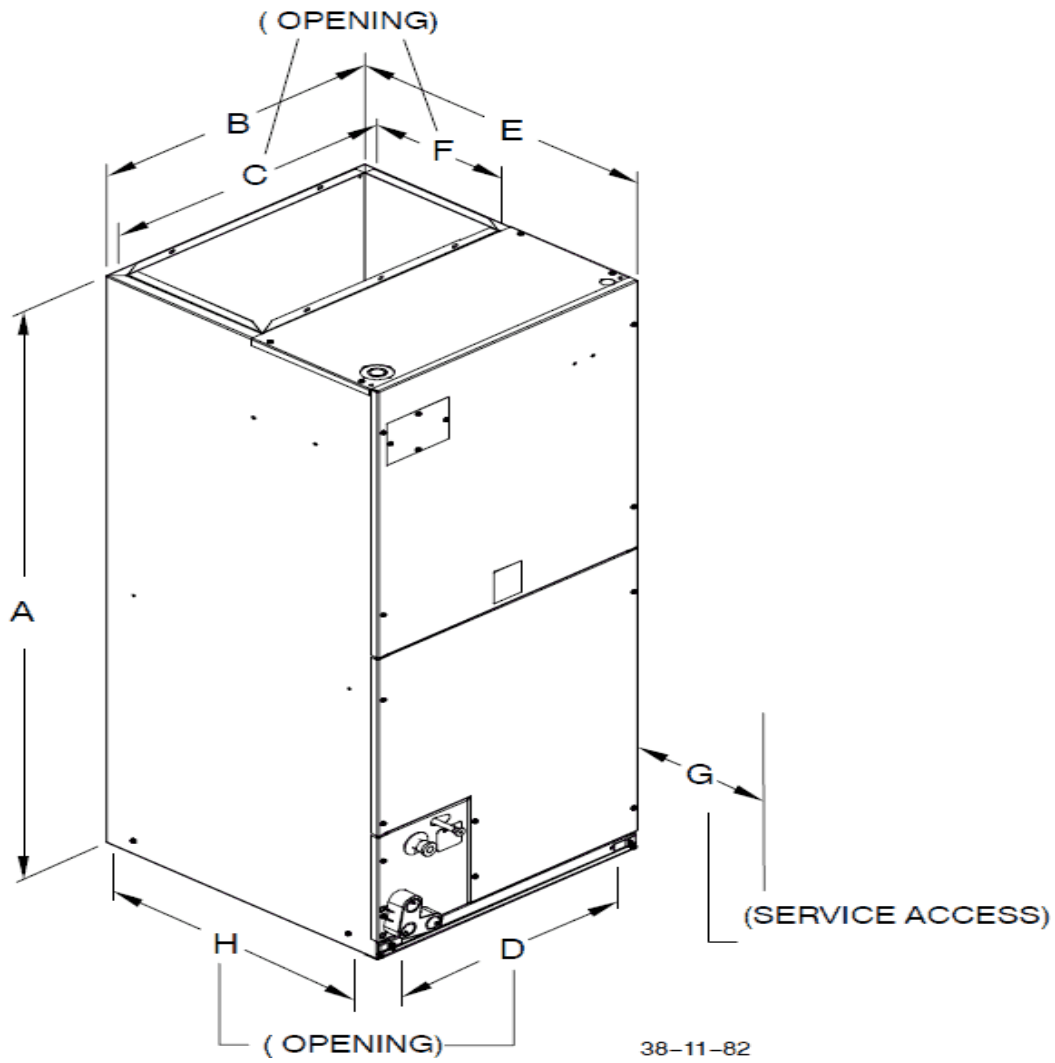

Dimensions (in.)							
A	B	C	D	E	F	G	H
42-11/16	14-5/16	12-7/16	12-5/16	22-1/16	11	21	19-13/16

AHRI Rated Cooling Performance

AHRI Certified Reference # 9487261
 AHRI Rated Cooling Capacity 22,800 Btuh
 EER 11.50 EER
 SEER 14 SEER
 Rated Indoor Coil: FEM4P2400AL

Cooling Performance @ Project Parameters

Net Cooling Capacity 21,529 Btuh
 Net Sensible Capacity 18,239 Btuh
 Net Latent Capacity 3,290 Btuh
 Total Supply Air 864 cfm
 Outdoor DB Temp 105.0 °F
 Entering DB Temp 80.0 °F
 Entering WB Temp 67.0 °F
 Leaving DB Temp 60.5 °F
 Leaving WB Temp 59.4 °F

Cooling derated for Altitude of 4000 feet

Electrical Data

Power Supply 208/230 Volts
 1 Phase
 60 Hertz
 Minimum Circuit Ampacity 14.1 Amps
 MOCP 20 Amps

Weight

Total Weight 119 lb

Field Installed Accessories

Features

Split System Air Conditioner

Refrigeration Circuit

- Scroll compressor
- Filter-Drier supplied
- Copper tube / aluminum fin coil

Easy to Install and Service

- Easy Access service valves
- External high and low refrigerant service ports
- Only two screws to access control panel
- Factory charged with R-410A refrigerant

Built to Last

- Baked-on powder coat finish over galvanized steel
- Post-painted (black) coil fins
- Coated Weather Resistant cabinet screws
- Coated inlet grille with 3/8" grille spacing

Warranty

- 5 year compressor limited warranty
- 5 year parts limited warranty (including compressor and coil)
- With timely registration, an additional 5 years. (including compressor and coil)
- Applies to original purchaser/homeowner, some limitations may apply. See warranty certificate for complete details.

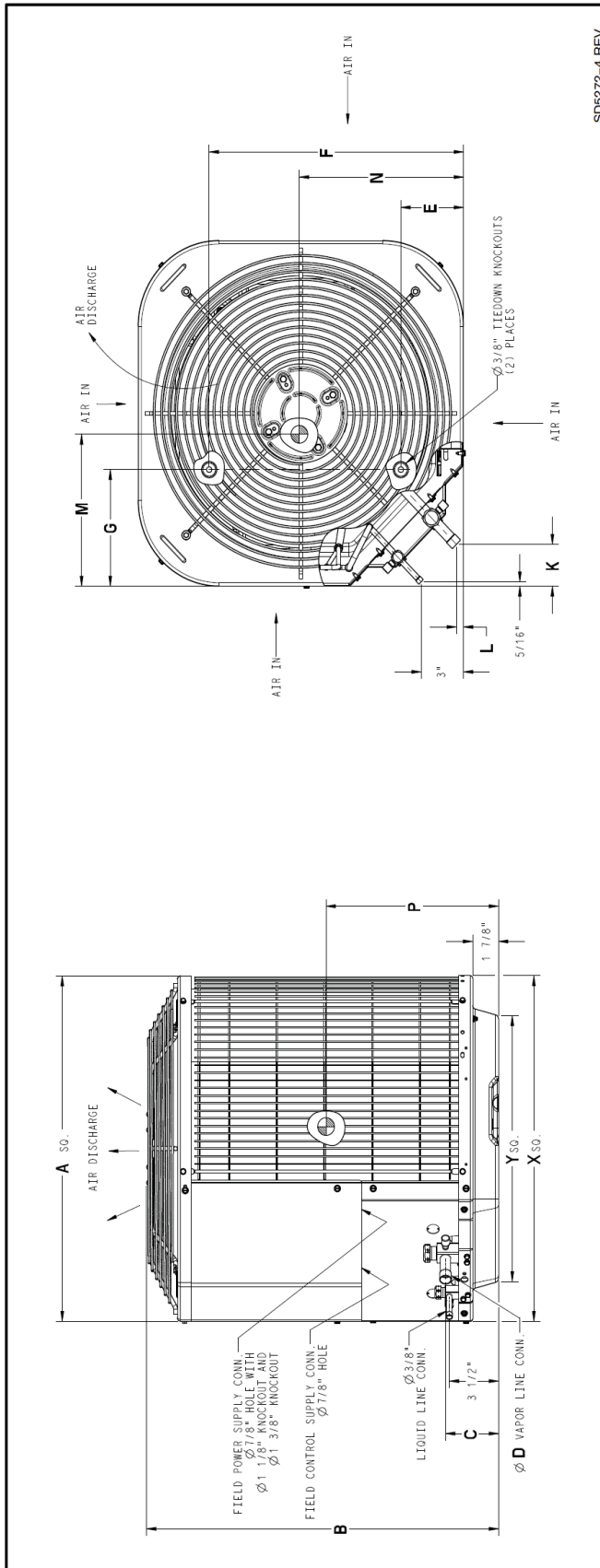

1. Allow 24" clearance to service side of unit, 48" above unit, 6" on one side, 12" on remaining sides.
2. Maintain a distance of 24" between units or 18" if no overhang within 12'.
3. Minimum outdoor operating ambient in cooling mode is 55°F, max 125°F.
4. Center of Gravity

Dimensions (in.)														
A	B	C	D	E	F	G	K	L	M	N	P	Crated Dimensions H x W x D		
25-3/4	25	3-3/4	3/4	4-7/16	21-1/4	9-1/8	2-13/16	1/2	13-5/8	12-1/8	9-7/8	25-3/4 x 25-3/4	20-7/16 x 20-7/16	27-7/8 x 27-7/8 x 32-9/16

Electric Resistance Heat

Model Number	EHK05AKN
Nominal Heat Size	5 kW
Electric Heat Voltage	230 Volts

Weight

Weight	112 lb
Electric Heat Weight	55 lb
Total Weight	167 lb

Supply Air Performance

Total Supply Air	864 cfm
External Static Pressure	0.30 in wg.
Blower Type	Direct Drive
Tap 5 Blower Speed	
Motor Rated HP	0.50 hp

Blower Performance corrected for Altitude of 4000 feet

Electrical Data

Power Supply	230 Volts
	1 Phase
	60 Hertz
Minimum Circuit Ampacity	28.4 Amps
MOCP	30 Amps

Field Installed Accessories

EHK05AKN - 5 kW

Features

FAN COIL

- Aluminum Tube, Aluminum Fin Evaporator
- Factory installed Piston with Teflon ring metering device
- Low voltage circuit protective fuse (3 amp) inline on wire harness
- Time Delay Relay (TDR)
- Sweat refrigerant connections
- Multiple electric entry location
- High efficiency ECM, 5-speed motor
- Units tested and certified by manufacturer to achieve 2% or less leakage rate at 1.0 inch water column
- 1 inch thick Insulation with R value of 4.2
- HUD approved for manufactured housing.

Warranty

- 1 year No Hassle Replacement™ limited warranty.
- 5 year parts limited warranty
- With timely registration, an additional 5 year parts limited warranty
- Applies to original purchaser/homeowner, some limitations may apply. See warranty certificate for complete details.

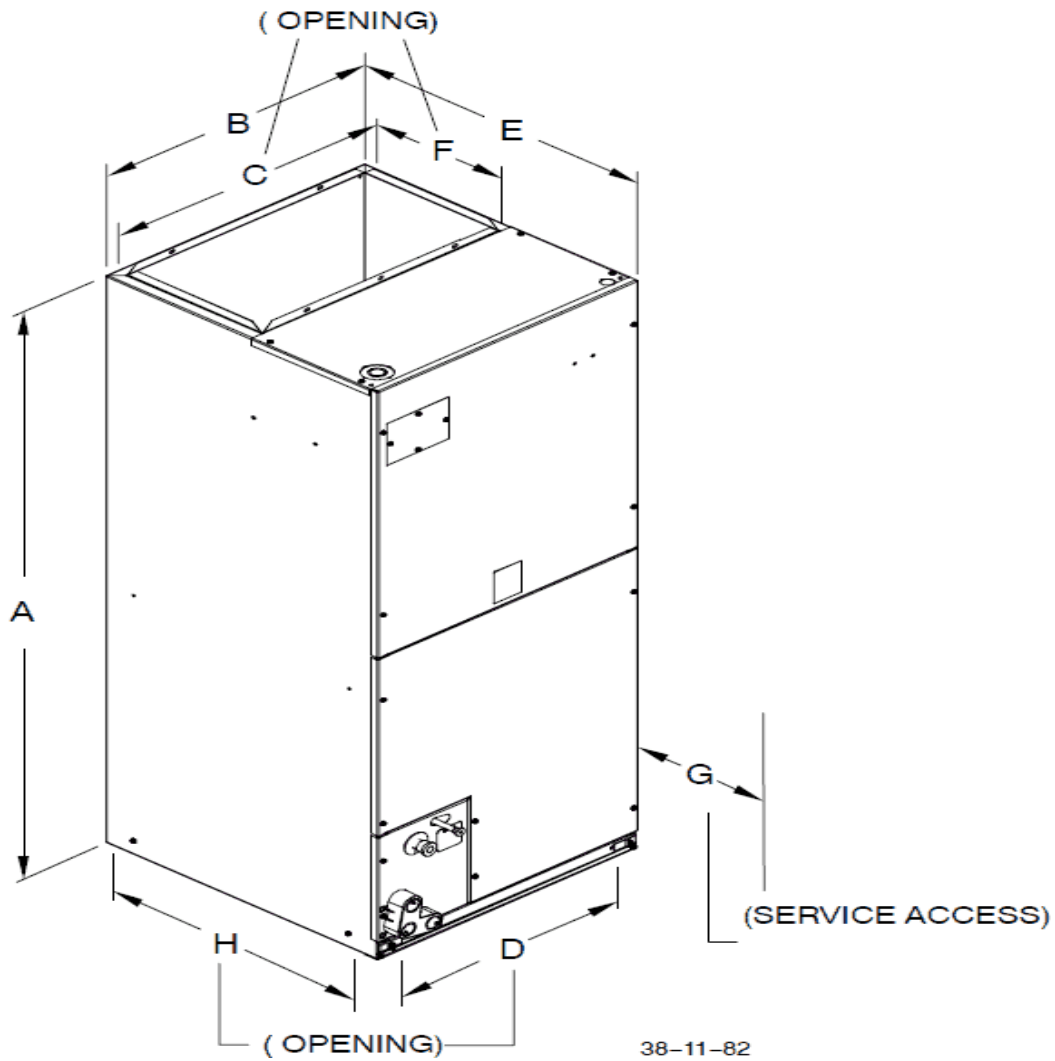

Dimensions (in.)							
A	B	C	D	E	F	G	H
42-11/16	14-5/16	12-7/16	12-5/16	22-1/16	11	21	19-13/16

AHRI Rated Cooling Performance

AHRI Certified Reference # 9487261
 AHRI Rated Cooling Capacity 22,800 Btuh
 EER 11.50 EER
 SEER 14 SEER
 Rated Indoor Coil: FEM4P2400AL

Cooling Performance @ Project Parameters

Net Cooling Capacity 21,529 Btuh
 Net Sensible Capacity 18,239 Btuh
 Net Latent Capacity 3,290 Btuh
 Total Supply Air 864 cfm
 Outdoor DB Temp 105.0 °F
 Entering DB Temp 80.0 °F
 Entering WB Temp 67.0 °F
 Leaving DB Temp 60.5 °F
 Leaving WB Temp 59.4 °F

Cooling derated for Altitude of 4000 feet

Electrical Data

Power Supply 208/230 Volts
 1 Phase
 60 Hertz
 Minimum Circuit Ampacity 14.1 Amps
 MOCP 20 Amps

Weight

Total Weight 119 lb

Field Installed Accessories

Features

Split System Air Conditioner

Refrigeration Circuit

- Scroll compressor
- Filter-Drier supplied
- Copper tube / aluminum fin coil

Easy to Install and Service

- Easy Access service valves
- External high and low refrigerant service ports
- Only two screws to access control panel
- Factory charged with R-410A refrigerant

Built to Last

- Baked-on powder coat finish over galvanized steel
- Post-painted (black) coil fins
- Coated Weather Resistant cabinet screws
- Coated inlet grille with 3/8" grille spacing

Warranty

- 5 year compressor limited warranty
- 5 year parts limited warranty (including compressor and coil)
- With timely registration, an additional 5 years. (including compressor and coil)
- Applies to original purchaser/homeowner, some limitations may apply. See warranty certificate for complete details.

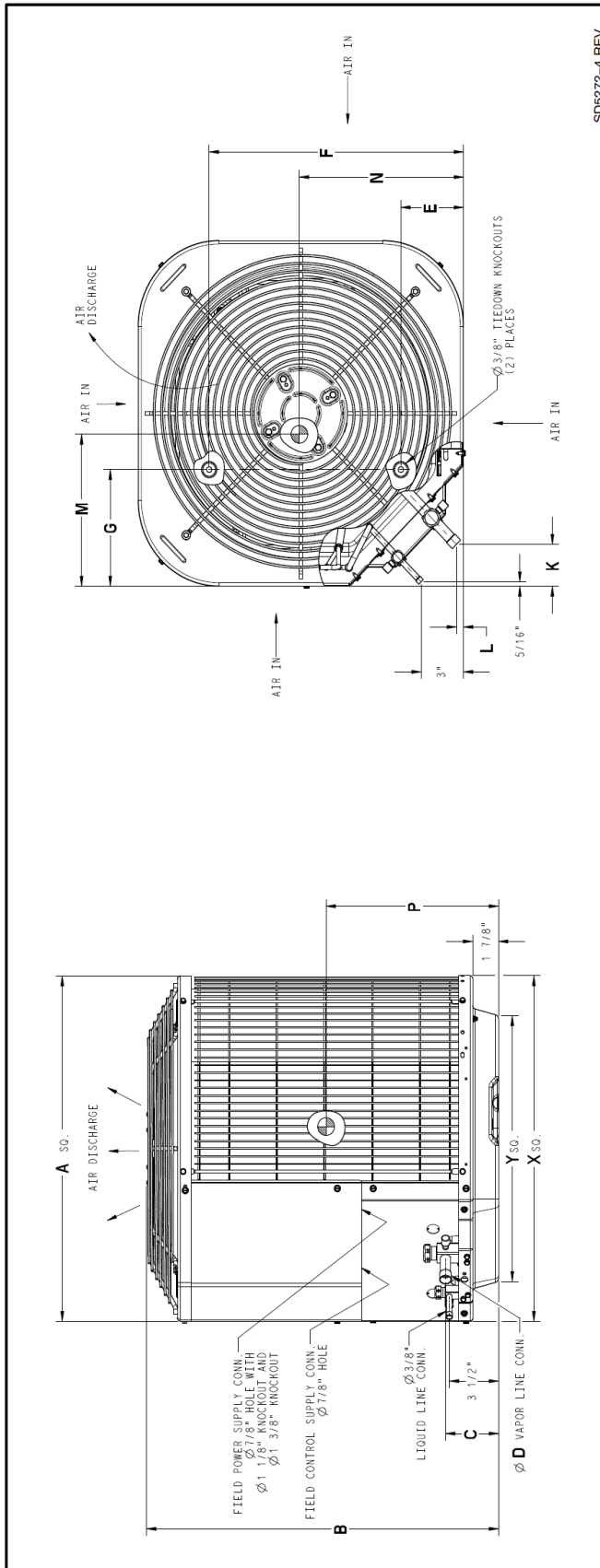

SD5272-4 REV

1. Allow 24" clearance to service side of unit, 48" above unit, 6" on one side, 12" on remaining sides.
2. Maintain a distance of 24" between units or 18" if no overhang within 12'.
3. Minimum outdoor operating ambient in cooling mode is 55°F, max 125°F.
4. Center of Gravity

Dimensions (in.)														
A	B	C	D	E	F	G	K	L	M	N	P	Crated Dimensions H x W x D		
25-3/4	25	3-3/4	3/4	4-7/16	21-1/4	9-1/8	2-13/16	1/2	13-5/8	12-1/8	9-7/8	25-3/4 x 25-3/4	20-7/16 x 20-7/16	27-7/8 x 27-7/8 x 32-9/16

Electric Resistance Heat

Model Number	EHK07AKN
Nominal Heat Size	7 kW
Electric Heat Voltage	230 Volts

Weight

Weight	112 lb
Electric Heat Weight	55 lb
Total Weight	167 lb

Supply Air Performance

Total Supply Air	864 cfm
External Static Pressure	0.30 in wg.
Blower Type	Direct Drive
Tap 5 Blower Speed	
Motor Rated HP	0.50 hp

Blower Performance corrected for Altitude of 4000 feet

Electrical Data

Power Supply	230 Volts
	1 Phase
	60 Hertz
Minimum Circuit Ampacity	48.5 Amps
MOCP	50 Amps

Field Installed Accessories

EHK07AKN - 7 kW

Features

FAN COIL

- Aluminum Tube, Aluminum Fin Evaporator
- Factory installed Piston with Teflon ring metering device
- Low voltage circuit protective fuse (3 amp) inline on wire harness
- Time Delay Relay (TDR)
- Sweat refrigerant connections
- Multiple electric entry location
- High efficiency ECM, 5-speed motor
- Units tested and certified by manufacturer to achieve 2% or less leakage rate at 1.0 inch water column
- 1 inch thick Insulation with R value of 4.2
- HUD approved for manufactured housing.

Warranty

- 1 year No Hassle Replacement™ limited warranty.
- 5 year parts limited warranty
- With timely registration, an additional 5 year parts limited warranty
- Applies to original purchaser/homeowner, some limitations may apply. See warranty certificate for complete details.

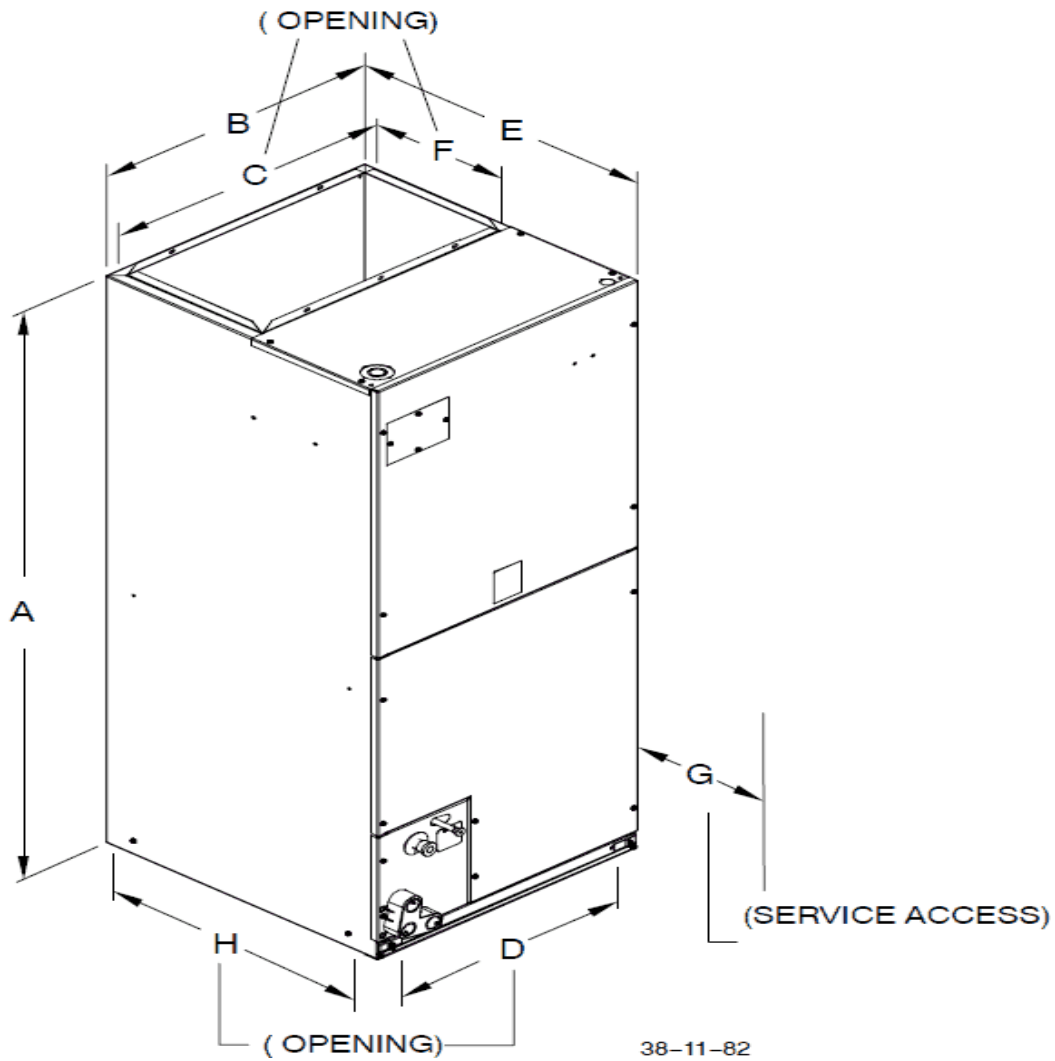

Dimensions (in.)							
A	B	C	D	E	F	G	H
42-11/16	14-5/16	12-7/16	12-5/16	22-1/16	11	21	19-13/16

International Comfort Products Limited Warranty Certificate

Covered Products: Split System Air Conditioner and Heat Pump Products Smaller than 65,000-Btuh Cooling Capacity (See Chart Below)

FOR WARRANTY SERVICE OR REPAIR:

Contact the installer or an International Comfort Products dealer. You may be able to find the installer's name on the equipment or in your Owner's Packet. You can also find an International Comfort Products dealer online at www.icpusa.com.

For help, contact: International Comfort Products, Consumer Relations, P.O. Box 4808, Syracuse, New York, 13221, Phone 1- 877- 591- 8908.

Product registration: You can register your product at: <https://productregistration.icpusa.com>.

Fill in the installation date, model and serial number of the unit in the space provided below and retain for your records.

Model No. _____ Serial No. _____

Date of Installation _____ Installed by _____

Name of Owner _____ Address of Installation _____

International Comfort Products ("ICP") warrants this product against failure due to defect in materials or workmanship under normal use and maintenance as follows. All warranty periods begin on the date of original installation and are for the duration, in years, listed below. If a part fails due to defect during the applicable warranty period ICP will provide a new or remanufactured part, at ICP's option, to replace the failed defective part at no charge for the part. Alternatively, and at its option, ICP will allow a credit in the amount of the then factory selling price for a new equivalent part toward the retail purchase price of a new ICP product. Except as otherwise stated herein, those are ICP's exclusive obligations under this warranty for a product failure. All warranties in this document are subject to all provisions, conditions, limitations and exclusions listed below and on the reverse of this document.

RESIDENTIAL APPLICATIONS

This warranty is to the original purchasing owner and subsequent owners only to the extent and as stated in the Warranty Conditions and below. The limited parts warranty period in years for residential applications, depending on the part and the claimant, is as shown in the table below.

No Hassle Replacement™ limited warranty – Available on qualifying models only, see chart below for list of covered models and duration of warranty. Available to original purchaser in owner-occupied single family residential applications only, and is not available to subsequent homeowners. If the compressor or condenser coil fails due to defect during the applicable No Hassle Replacement limited warranty time period, a one-time replacement with a comparable ICP unit will be provided. This unit replacement warranty is in addition to the standard parts warranty. Proof of purchase and installation date will be required. No Hassle Limited Warranty replacements are subject to review and verification by an ICP representative. The remaining balance of the original unit's standard warranty will be transferred to the replacement unit. This limited warranty is subject to all provisions, conditions, limitations and exclusions listed below and on the reverse of this document.

Product Family	Warranty Period in Years		
	No Hassle †	Parts (Including Compressor and Coil)	
	Original Owner	Original Owner	Subsequent Owners
CCA7, HCA7, TCA7, CCA9, HCA9, TCA9, CCH6, HCH6, TCH6, CCH9, HCH9, TCH9, CVH8, HVH8, TVH8, CVA9, HVA9, TVA9	10	5 or 10*	5
CSH5, HSH5, TSH5, CSH6, HSH6, TSH6, CSA6, HSA6, TSA6, CXA6, HXA6, TXA6, CXH5, HXH5, TXH5	5	5 or 10*	5
CSH4, HSH4, TSH4, CSA5, HSA5, TSA5	3	5 or 10*	5
C4A3, H4A3, T4A3, C4H3, H4H3, T4H3	1	5 or 10*	5
HC4A3, HC4H3, NH4A4, NH4H4	-	5 or 10*	5
N4A3, N4A4, N4A5, N4A6, N4A7, N4H3, N4H4, N4H6, NXA4, NXA6, NXH5, NXH6, R4A3, R4A4, R4A5, R4H3, R4H4	-	5 or 10*	5
Three- Phase Models	No Hassle	Compressor	Parts
H4A3, H4H3, N4A3, N4H3, HC4A3, HC4H3, N4H4	-	5	1

†See warranty Conditions on reverse.

*If properly registered within ninety (90) days after original installation, parts are warranted for a period of ten (10) years to the original purchaser. Otherwise, parts warranty is five (5) years (except in California and Quebec, and other jurisdictions that prohibit warranty benefits conditioned on registration).

OTHER APPLICATIONS

For all applications other than residential applications, the warranty period is five (5) years on the compressor and one (1) year on all other parts. The warranty is to the original owner only and is not available for subsequent owners.

LEGAL REMEDIES - The owner **must** notify the Company in writing, by certified or registered letter to ICP, Warranty Claims, P.O. Box 4808, Syracuse, New York 13221, of any defect or complaint with the product, stating the defect or complaint and a specific request for repair, replacement, or other correction of the product under warranty, mailed at least thirty (30) days before pursuing any legal rights or remedies.

International Comfort Products Limited Warranty Certificate

CONDITIONS:

The Limited Warranty only applies if the following conditions are met:

1. To obtain the longer warranty periods as shown in the table under original owner, the product must be properly registered at <https://productregistration.icpusa.com> within ninety (90) days of original installation. In jurisdictions where warranty benefits conditioned on registration are prohibited by law, registration is not required and the longer warranty period shown will apply.
2. If the original installation date cannot be verified, then the warranty period begins ninety (90) days from the date of product manufacture (as indicated by the model and serial number). Where a product is installed in a newly constructed home, the date of installation is the date the original homeowner purchased the home from the builder.
3. The limited parts warranty period as shown in the table under subsequent owner does not require registration.
4. Proof of purchase may be required at time of service.
5. The unit must be installed, and warranty work must be performed, by a licensed dealer or contractor.
6. The unit must be installed in accordance with ICP's installation instructions and in compliance with local codes. Improper installation may endanger the occupants of the dwelling or damage the product.
7. The unit must be operated in accordance with ICP's owner's manual provided with each unit. The product must not be misused.
8. The unit's rating plate must not be removed or defaced.
9. Proof must be supplied that the equipment has been properly maintained over the life of the warranty, i.e., a minimum of once-a-year maintenance.
10. The unit must be installed and located in the continental U.S.A., Alaska, Hawaii, or Canada.
11. Warranties apply only to products installed in their original installation location.
12. Defective parts must be returned to the distributor through a servicing dealer for credit.
13. The No Hassle Replacement limited warranty applies only if the following conditions are met:
 - a. Claimant is the original purchaser of the product.
 - b. An ICP outdoor unit must be installed in combination with a matching indoor coil, the combination must be certified and listed in the AHRI Unitary Directory of Certified Products (AHRI = Air- Conditioning, Heating, and Refrigeration Institute).
 - c. The matching indoor coil must use a TXV or Piston refrigerant metering device
 - d. The supplied filter-drier must be installed per the installation instructions.
14. All other accessories, including electric heaters used in commercial applications, will have a one (1) year limited warranty from date of installation.

LIMITATIONS OF WARRANTIES – All implied warranties (and implied conditions in Canada) including implied warranties or conditions of merchantability and fitness for a particular use or purpose are hereby limited in duration to the period for which the limited warranty is given and applies. Some states or provinces do not allow limitations on how long an implied warranty or condition lasts, so this limitation may not apply to you. The express warranties made in this warranty are exclusive and may not be altered, enlarged, or changed by any distributor, dealer, or other person, whatsoever.

THIS WARRANTY DOES NOT COVER:

1. Labor or other costs incurred for diagnosing, repairing, removing, installing, shipping, servicing, or handling of either failed parts, or replacement parts, or new units.
2. Any product not installed pursuant to any applicable governmental minimum efficiency standards.
3. Normal maintenance as outlined in the installation and servicing instructions or owner's manual including coil cleaning, filter cleaning and/or replacement, and lubrication.
4. Damage or repairs required as a consequence of improper shipping or handling, faulty installation, misapplication, abuse, improper servicing, unauthorized alteration, and/or improper operation.
5. Failure to start or damages due to voltage conditions, blown fuses, open circuit breakers, or the inadequacy, unavailability, or interruption of electrical, Internet service provider, or mobile device carrier service or your home network.
6. Failure or damage as a result of floods, winds, fires, lightning, accidents, corrosive environments (except for coastal rated units in coastal environments), rust and wear, or other conditions beyond the control of ICP.
7. Parts not supplied or designated by ICP, or damages resulting from their use.
8. Electricity or fuel costs or increases in electricity or fuel costs from any reason whatsoever including additional or unusual use of supplemental electric heat.
9. **Any special, indirect, or consequential property or commercial damage of any nature whatsoever.** Some states do not allow the exclusion of incidental or consequential damages, so the above limitation may not apply to you.
10. Refrigerant or any costs related thereto.
11. Any product purchased on the Internet.

This warranty gives you specific legal rights, and you may also have other rights which vary from state to state or province to province.

In the USA:
International Comfort Products
650 Heil- Quaker Avenue
P.O. Box 128
Lewisburg, Tennessee 37091
(931) 270-4100

In Canada:
International Comfort Products
Division of UTC Canada Corporation
6060 Burnside Court, Unit 1
Mississauga, Ontario L5T 2T5
(905) 795-8113

Copyright 2017 International Comfort Products
Manufacturers of Airquest®, Arcoaire®, Climette®, Comfortmaker®, Day & Night®, Heil®, ICP Commercial®, Keeprite®, Maratherm®, Tempstar® and other quality brand name private label products.

401 06 4300 18 August 2017

PFXC1180 Series

Two Handle Kitchen Faucet



Product Features

- Ceramic Cartridges
- Metal Lever Handles
- Max. flow rate: 1.5 GPM
- With side spray (PFXC1180CP)
- Meets ANSI: A112.18.1M
- NSF 61-9 compliant
- ADA Compliant



PFXC1180CP

Model Numbers

PFXC1180CP-with side spray

PFXC1180LSCP-less side spray

Polished chrome

Polished chrome

PFXC1180LSCP

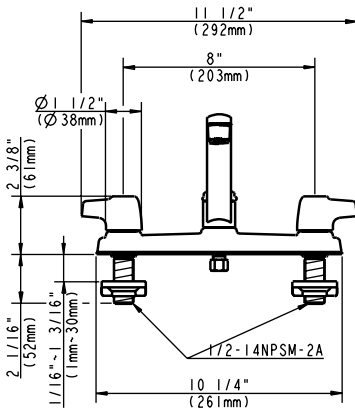

PFXC1180CP

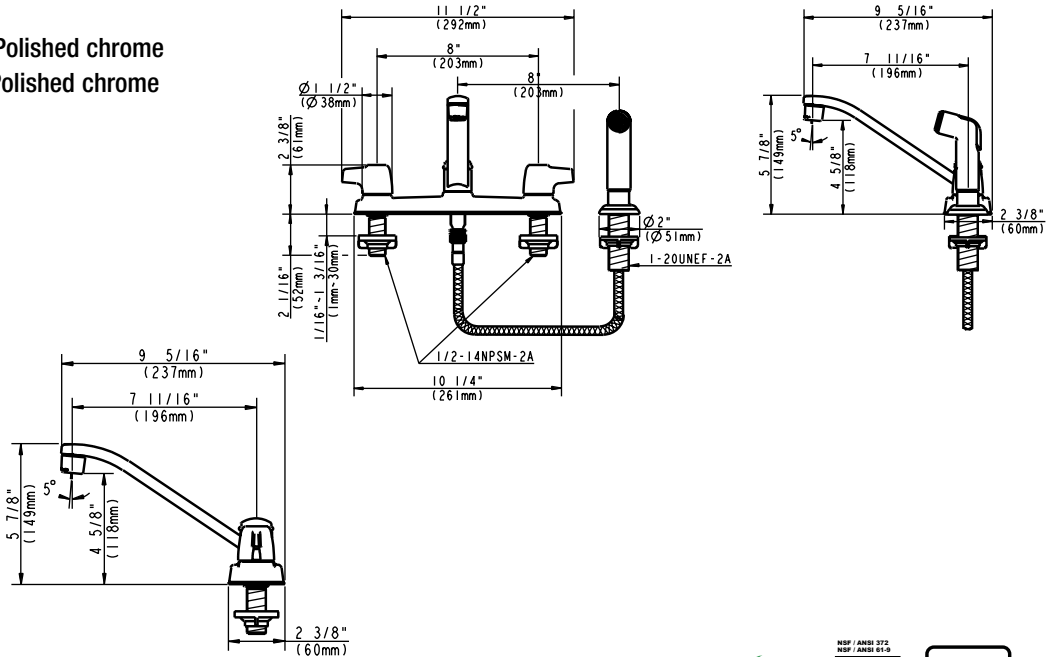

Warranty and Codes

This product comes complete with installation, operating, care and maintenance instructions. This PROFLO faucet carries a limited lifetime warranty when installed in residential applications.

The warranty is five years in commercial applications.

This product meets ANSI: A112.18.1M.

Compliant with lead content requirements of California AB 1953.

* All measurements are nominal. Please verify before actual installation.

Distributed Exclusively by Ferguson and Wolsley Canada

PFSR3322 Series

Stainless Steel Sinks



Product Features

- Stainless steel double bowl sink
- Self-rimming
- Sink clips included for counter tops up to 3/4" thick
- Available with 3 or 4 faucet holes
- 20 or 22 gauge
- Overall Size 33" x 22"
- Bowl Size 14" x 15-3/4"
- Bowl depth 6-1/8", 7-1/8" or 8-1/8"
- Drain diameter 3 1/2"
- Minimum cabinet size 36"
- Under spray coating and pads for sound deadening and insulation
- 6" bowls are ADA compliant when installed to ADA guidelines



PFSR332264

Model Numbers

- PFSR332263 33X22 3H 6.0 22 GA 2B SS SINK ADA compliant
- PFSR332264 33X22 4H 6.0 22 GA 2B SS SINK ADA compliant
- PFSR332273 33X22 3H 7.0 20 GA 2B SS SINK
- PFSR332274 33X22 4H 7.0 20 GA 2B SS SINK
- PFSR332283 33X22 3H 8.0 20 GA 2B SS SINK
- PFSR332284 33X22 4H 8.0 20 GA 2B SS SINK

MODEL	DEPTH "A"	
	IN	MM
PFSR33226	6-1/8"	154 mm
PFSR33227	7-1/8"	179 mm
PFSR33228	8-1/8"	205 mm

Product Specifications

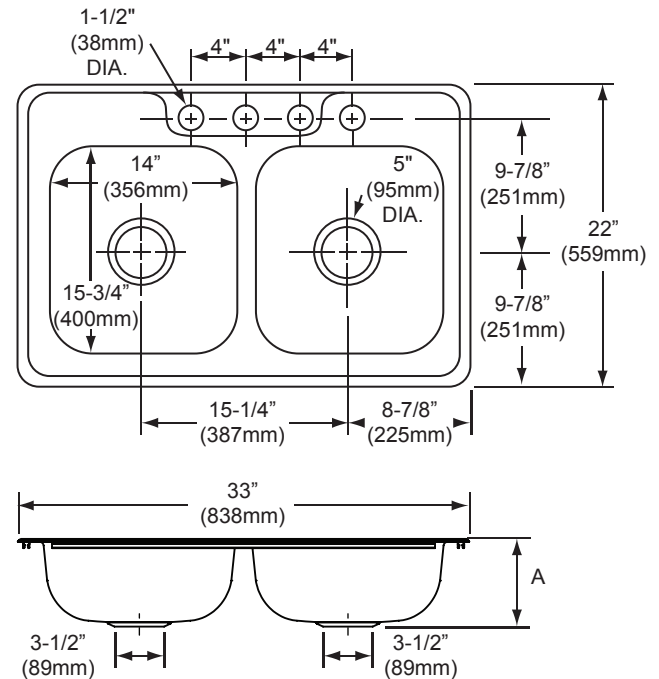

* All measurements are nominal. Please verify before actual installation.

Available Parts

- PFCLIP Box of 10 clips for self rimming sinks for counter tops up to 1-1/2" thick.
- PFG1112 Sink basin grid

Warranty and Codes

This PROFLO stainless steel sink carries a 2- year limited warranty. In an effort to continually improve our products, we will make design changes from time to time. We reserve the right to ship newly designed product to fill any order unless it is agreed in writing to do otherwise.

Sink complies with ASME A112.19.3-2008 CSA B45.4-08.



PFWSC3016 series

SINGLE HANDLE LAVATORY FAUCET



Product Features

- Ceramic disc cartridge
- Metal handle
- With 50/50 Pop-up
- 3-hole 4" on-center installation
- Flow rate: 1.2 GPM at 60 PSI (PFWSC3016)
- Flow rate: 0.5 GPM at 60 PSI (PFWSC30165)
- ADA compliant
- cUPC/IAPMO listed
- WaterSense certified



PFWSC3016CP

Model Numbers

- PFWSC3016CP chrome
- PFWSC3016BN brushed nickel
- PFWSC3016ORB oil rubbed bronze
- PFWSC30165CP chrome

Product Specifications

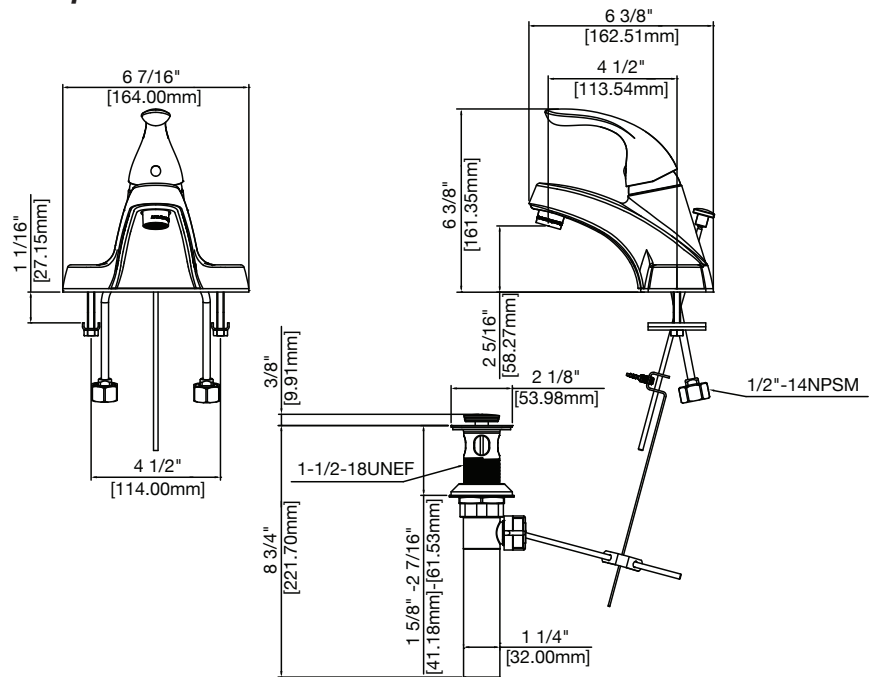

Available Parts

- PF3357061 Cartridge
- PFX14322 Aerator for PFWSC30165 (without aerator shell)
- LIN655641 Aerator for PFWSC30165 (aerator shell & aerator insert)

Warranty and Codes

This product comes complete with installation, operating, care and maintenance instructions. This PROFLO faucet carries a limited lifetime warranty when installed in residential applications. The warranty is five years in commercial applications. This product meets ASME: A112.18.1.

*Compliant with lead content requirements of California AB 1953.



Distributed Exclusively by Ferguson and Wolseley Canada

PF20171 / PF20174 / PF20178

Drop-in Lavatory Vitreous China - 20" x 17"



Product Features

- Vitreous china
- Self-rimming lavatory
- Concealed front overflow drain
- Available 4CC, 8CC or single faucet hole
- Can be mounted for ADA Installation

Codes and Standards

- ADA
- IAPMO/UPC
- ASME/ANSI A112.19.2M
- CSA B45



PF20174

Specified Model

Model	Model Description	Color Finishes
PF20171	Drop-in lav 17 1/2" x 20 1/2"- single faucet hole	○ White
PF20174	Drop-in lav 17 1/2" x 20 1/2"-- 4cc	○ White ○ Biscuit
PF20178	Drop-in lav 17 1/2" x 20 1/2"-- 8cc	○ White ○ Biscuit



PF20171 / PF20174 / PF20178

Drop-in Lavatory Vitreous China - 20" x 17"



Product Specification:

The self-rimming lavatory shall be 17 1/2" in length by 20 1/2" in width. Lavatory shall be made of vitreous china. Lavatory shall have 4" centers (PF20174), 8" centers (PF20178) or single faucet hole (PF20171).

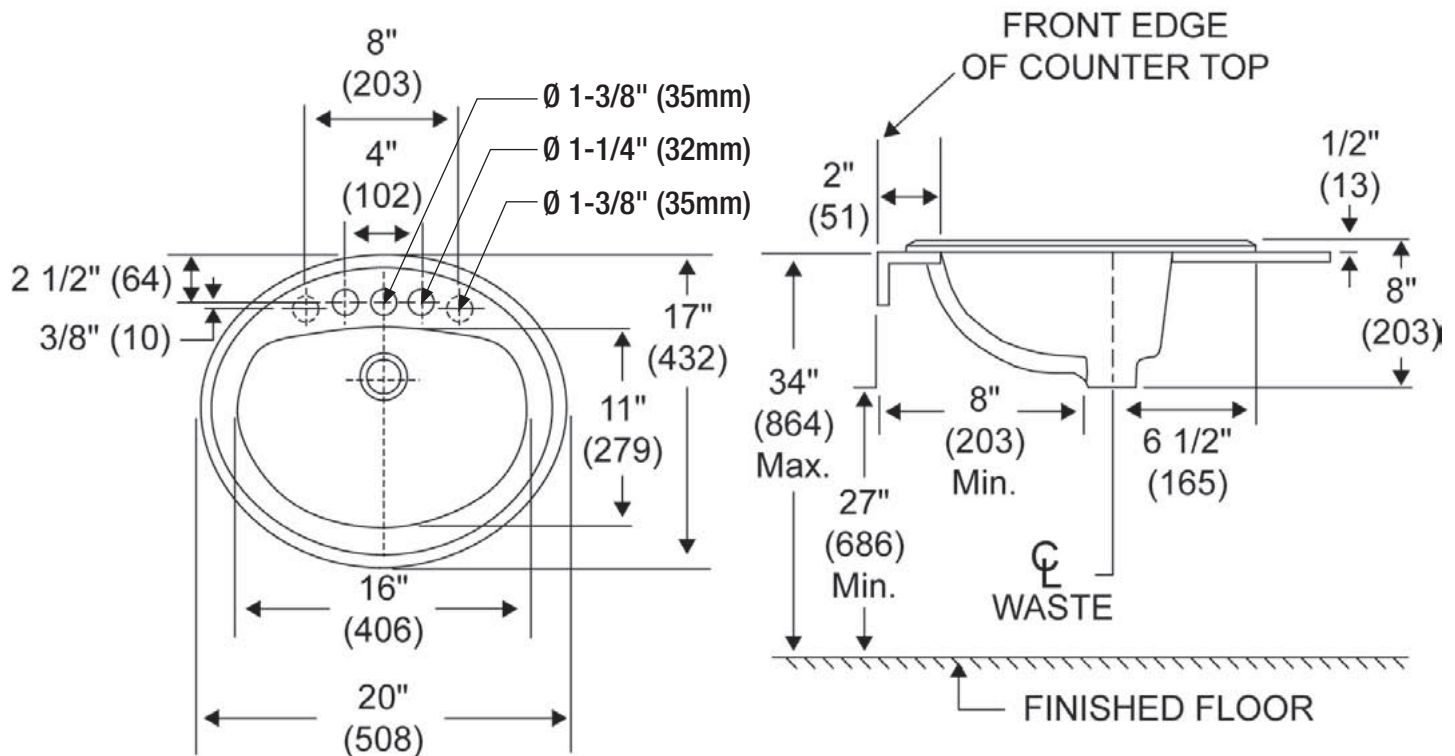

Warranty and Codes:

These products come complete with installation, operating, care and maintenance instructions. All PROFLO fixtures carry a 1-year limited warranty. These products meet or exceed ASME/ANSI A112.19.2M. In an effort to continually improve our products, we will make design changes from time to time. We reserve the right to ship newly designed product to fill any order unless we agree in writing to do otherwise.



Freestanding Ranges

FFEF3016T S/M/W/B

30" Electric



Product Dimensions

Height (Max.)	46-5/8"
Width	29-7/8"
Depth (Including Handle)	28-1/2"

More Easy-To-Use Features

Built with American Pride

Designed, engineered and assembled in the U.S.A.

Auto Shut-Off

As an extra safety measure, the oven will automatically shut off after 12 hours.

Color-Coordinated Oven Door with Extra-Large Window

Our extra-large oven window makes it easier to check on the status of your dish without having to open the oven door.

Electronic Kitchen Timer

Times up to 12 hours.

Available in:



Elements	Size	Watts
Right Front	6"	1,500
Right Rear	8"	2,600
Left Front	8"	2,600
Left Rear	6"	1,500

Signature Features

One-Touch Self Clean

Your oven cleans itself - so you don't have to. Self clean options available in 2- and 3-hour cycles.

Store-More™ Storage Drawer

With the Store-More™ Storage Drawer, you will have extra space to store your cookware.

Delay Clean

Set the oven to begin cleaning on your schedule.

Large Capacity

Our large capacity oven gives you room to cook more dishes at once.

Features	
Oven Control/Timing System	Ready-Select® Controls
Surface Type	Black Porcelain (S/M), Color-Coordinated Porcelain (W/B)
Window	Extra-Large
Exterior Door Finish	Stain. Steel (S), Silver Mist (M), Color-Coord. (W/B)
Handle Design	Black (S/M), Color-Coordinated (W/B)
Exterior Finish (Side Panels)	Black (S/M), Color-Coordinated (W/B)
Convection System	
Oven Cleaning System	Self Clean
Drawer Functionality	Storage
Oven Controls	
Bake	Yes
Broil	Low and High
Add-a-Minute	
Delay Bake	
Self-Clean	Yes
Quick Clean Option	Yes
Delay Clean	2, 3 Hour
Kitchen Timer	Yes
Timed Cook Option	
Auto Oven Shut-Off	12 Hours
Oven Lock-Out	
Cooktop Features	
Right Front Element (Watts)	6" - 1,500
Right Rear Element (Watts)	8" - 2,600
Left Front Element (Watts)	8" - 2,600
Left Rear Element (Watts)	6" - 1,500
Center Element (Watts)	
Element "On" Indicator Light	Yes
Coil Cooktop/Drip Bowls	Yes/Chrome
Oven Features	
Capacity (Cu.Ft.)	5.3
Oven Light	1
Hidden Bake Element	
Rack Configuration	2 Standard
Baking System	Even Baking Technology
Broiling System	Vari-Broil™ Hi/Lo
Bake Element/Broil Element (Watts)	2,600/3,000
Specifications	
Oven Interior (H x W x D)	19-3/4" x 24-3/8" x 19-1/8"
Power Supply Connection Location	Middle Bottom Rear
Voltage Rating	240V/208V/60Hz
Connected Load (kW Rating) @ 240/208 Volts	11.5/8.5
Minimum Circuit Required (Amps)	40
Shipping Weight (Approx.)	160 Lbs.

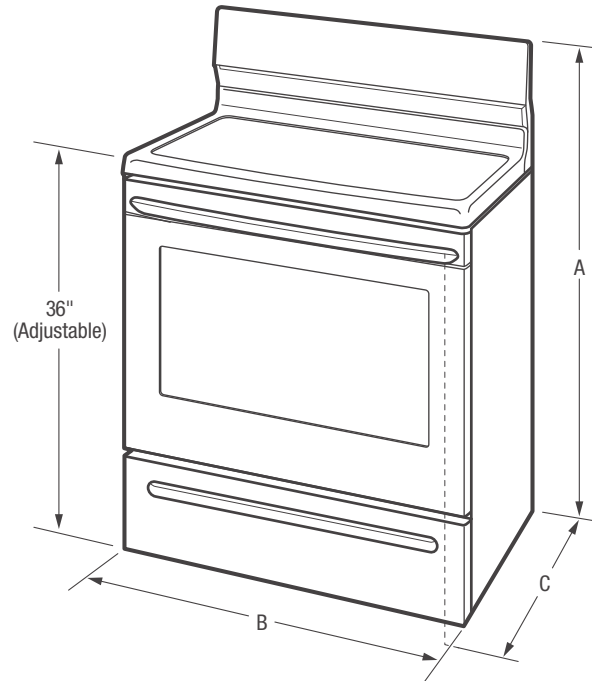

NOTE: For planning purposes only. Always consult local and national electric codes. Refer to Product Installation Guide for detailed installation instructions on the web at frigidaire.com.



Product Dimensions	
A - Height (Max.)	46-5/8"
B - Width	29-7/8"
C - Depth (Including Handle)	28-1/2"
Depth with Door Open 90°	48-3/8"

Cutout Dimensions	
Height (Standard)	36"
Width (Min.)	30"
Depth (Min.)	24"

Accessories information available on the web at frigidaire.com

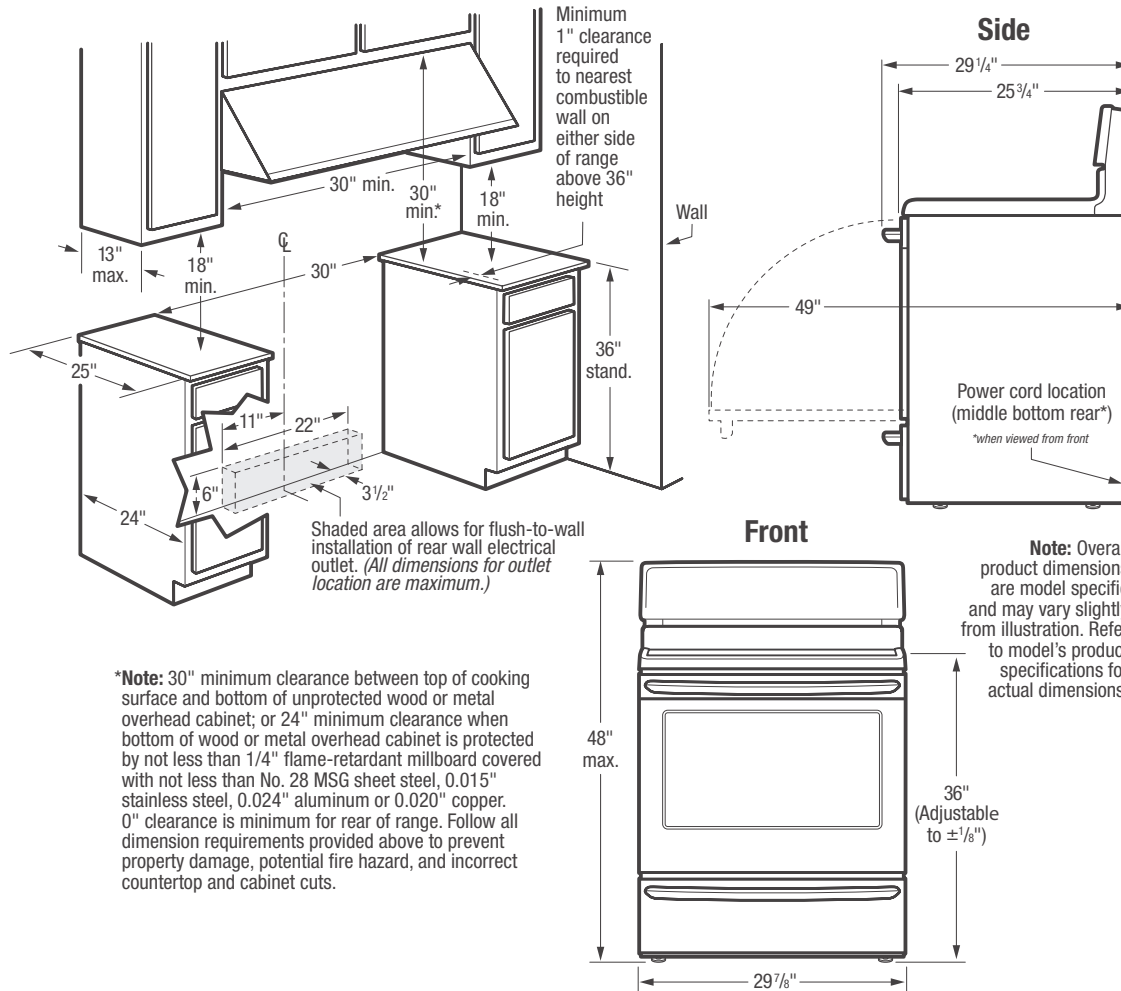

Freestanding Range Specifications

- Product Shipping Weight (approx.) - 160 Lbs.
- Single phase 3- or 4-wire cable, 120/240 or 120/208 Volt, 60 Hertz, fused on both sides of line with ground.
- Connected Load (kW Rating) @ 240/208 Volts = 11.5/8.5kW
- Recommended Circuit Breaker - 40 Amps
- Always consult local and national electric codes.
- Make sure wall coverings around range can withstand heat generated by range.
- Floor beneath range MUST be solid and level.
- Overhead cabinetry should not exceed a 13" maximum depth.
- Absolute minimum horizontal distance between overhead cabinets installed to either side of appliance must be no less than maximum width of appliance.
- Range can be installed flush to wall with 0" minimum rear clearance.
- Minimum 1" clearance required from edge of rangetop to nearest combustible wall on either side of range above 36" height.

- Allow 30" minimum clearance between top of cooking surface and bottom of unprotected wood or metal overhead cabinet; or 24" minimum clearance when bottom of wood or metal overhead cabinet is protected by not less than 1/4" flame retardant millboard covered with not less than No. 28 MSG sheet steel, 0.015" stainless steel, 0.024" aluminum or 0.020" copper.
- To reduce risk of fire when using overhead cabinetry, install range hood that projects horizontally a recommended minimum of 5" beyond bottom of cabinets.
- Follow all dimension requirements provided to prevent property damage, potential fire hazard, and incorrect countertop and cabinet cuts.

Note: For planning purposes only. Refer to Product Installation Guide on the web at frigidaire.com for detailed instructions.





offerings



Product Shown: Seville Passage Lever in Satin Nickel (619)



about us

Schlage has built a legacy of providing the highest level of security to homes and businesses. Install a Schlage, and you install nearly a century of total dedication to security, quality and innovation.



SECURITY

- ANSI Grade 1 F-Series grip handlesets
- ANSI Grade 2 knobs & levers
- One-piece knob designs

CONVENIENCE

- Field reversible levers
- Universal backset latches
- Available triple option latch faceplates
- Self-aligning screw posts for quick installation
- Adjustable throughbolt post on all grip handlesets – slides up to 1-1/2" to easily fit existing door preps

QUALITY

- Lifetime Mechanical Warranty
- Lifetime Finish Warranty – all finishes excluding Oil Rubbed Bronze
- Available UL option
- Finish on strikes, faceplates, and screws match finish on lock



SECURITY

- ANSI Grade 3 knobs, levers, grip handlesets & deadbolts
- 3" strike frame reinforcing screws on deadbolts
- One-piece knob designs

CONVENIENCE

- Field reversible levers
- Universal backset latches
- Available triple option latch faceplates
- Keyable to all C-keyway Schlage products

QUALITY

- Lifetime Mechanical Warranty
- 5-Year Finish Warranty
- Available UL option
- Finish on strikes, faceplates, and screws match finish on lock

For more information about Schlage or Dexter, please visit www.schlage.com

DESIGN

- Established design company providing high-quality architectural hardware products
- Expansive range of styles and finishes
- Styles support a broad spectrum of design concepts
- Combines high end materials with old world manufacturing processes



CONVENIENCE

- Reversible Latch Bolts for simple handing
- Matching Strikes, Latchface and Screws
- All interior locks "Auto-Adjust" Door Thickness of 1-1/4" to 2" – specified to 3"
- Both Decorative and Production Rose Screws included as Standard

QUALITY

- Limited Lifetime Warranty on Finish & Mechanical
- Matching or Coordinating Cylinder Plug Finish
- ANSI Grade 2 Latch Performance

For more information, please visit www.fusionhardware.com

EXTERIOR



description: KNOB - ENTRY
series/style: STRATUS
product: J54 STR
color: SATIN NICKEL (619)

INTERIOR



description: KNOB - PASSAGE
series/style: K11
product: J10BB K11
color: SATIN STAINLESS STEEL (630)

Privacy knob available
(not pictured)



description: DEADBOLT
series/style: SINGLE CYLINDER
product: JD60 619
color: SATIN NICKEL (619)

PF7610G series

Single Handle Shower Only Trim Kit



Product Features

- Metal lever handle
- Metal shower arm and stainless steel flange
- Single function showerhead with easy-clean rubber nozzles
- 100% factory pressure tested
- 1.75 gpm flow showerhead
- cUPC/IAPMO Listed
- ADA Compliant
- WaterSense Certified
- Use with ACCUFIT PF3001 series valve



PF7610GCP

Model Numbers

PF7610GCP	Chrome
PF7610GBN	Brushed nickel

Product Specifications

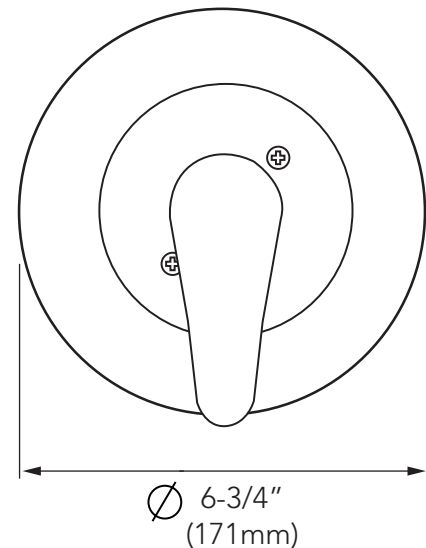
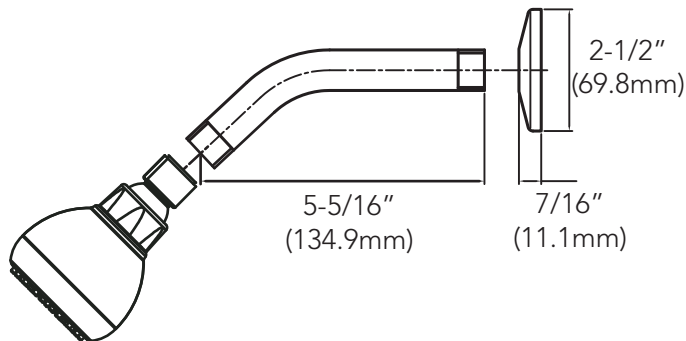

Warranty and Codes

This product comes complete with installation, operating, care and maintenance instructions. This PROFLO faucet carries a limited lifetime warranty when installed in residential applications. The warranty is five years in commercial applications. This product meets ASME: A112.18.1.



PFTSHEC1000 / PFTSHEC2000



Heavy Duty Plastic Toilet Seats with Easy Clean

Product Features

- Durable, high quality solid plastic construction
- Closed front with cover
- Top mount concealed hinge with slip resistant pads
- Easy installation
- Large, color matched bumpers
- Metal fasteners and hinge pins for added durability
- Withstands cleaners, strong chemicals
- New slide-off hinge for easy cleaning

Product Specifications

- Ring Thickness: 18 mm / .75"
- Ring Thickness including the bumper is: 26 mm / 1"
- Height of seat with cover is: 55mm / 2.25"



PFTSHEC1000



PFTSHEC2000

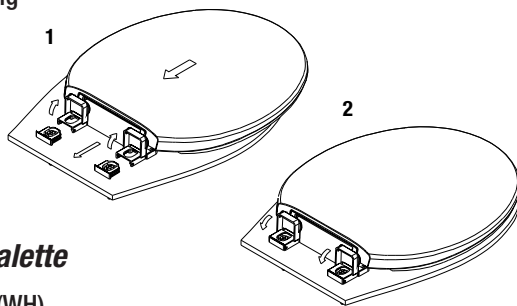

Color Palette

- White (WH)
- Biscuit (BS)

Model Numbers

- PFTSHEC1000** Round front plastic toilet seat with easy clean
- PFTSHEC2000** Elongated plastic toilet seat with easy clean

Model Numbers	A	B	C	E	F
PFTSHEC1000 Round front	5 1/2"	16 7/8"	14 5/16"	10 3/16"	8 5/16"
PFTSHEC2000 Elongated front	5 1/2"	18 7/8"	14 3/16"	11 7/8"	8 3/16"

Product Specifications

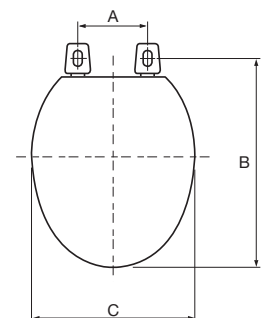
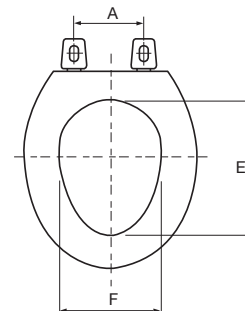
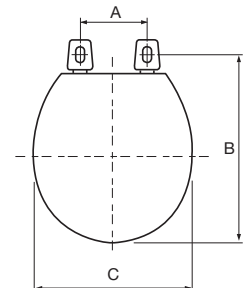
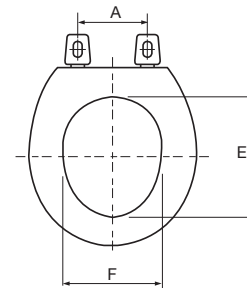

Warranty and Codes

PROFLO toilet seats carry a 1-year limited warranty. In an effort to continually improve our products, We will make design changes from time to time. We reserve the right to ship newly designed product to fill any order unless we agree in writing to do otherwise.

PF1400T Series

High-Efficiency Two Piece Toilet



Product Features

- Gravity fed 1.28gpf HET, High Efficiency Toilet
- Two piece vitreous china
- 2" fully glazed trapway
- 8" x 9" water surface
- Anti-siphon fill valve
- Jetted box rim
- Close coupled tank with cover
- Quick connect, 2 bolt tank to bowl installation
- Comes standard with a color matching trip lever
- 2" Flush valve
- Sanitary bar on all bowls
- Seat and supply not included
- Available in 10", 12", 14" RI
- Available with RH trip level
- Available with insulated tank
- Available round front, elongated, and ADA
- Uses 20% less water than standard low consumption toilets
- EPA WaterSense Certified



PF1403TWH/PF5112HEWH

Codes and Standards

- ADA PF1403T
- IAPMO/UPC
- ASME A112.19.2
- CSA B45.0
- CSA B45.1

Model	Description	Color Finishes	
PF1400T	1.1-1.6 12 RI RF UNIV BOWL	○ White	○ Biscuit
PF1401T	1.1-1.6 12 RI EL UNIV BOWL	○ White	○ Biscuit
PF1403T	1.1-1.6 12 RI ADA UNIV BOWL	○ White	○ Biscuit
PF5112HE	HET Tank only 12" RI for 1400 series	○ White	○ Biscuit
PF5110HE	HET Tank only 10" RI for 1400 series	○ White	○ Biscuit
PF5114HEWH	HET Tank only 14" RI for 1400 series	○ White	
PF5112RHEWH	HET RH Tank only 12" RI for 1400 series	○ White	
PF5112UHEWH	HET Lined Tank only 12" RI for 1400 series	○ White	

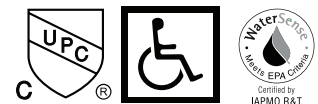

PF1400T Series

High-Efficiency Two Piece Toilet



Product Features

The combination toilet shall be made of vitreous china. Toilet shall be 1.28 gpf (4.8 lpf). Toilet shall have 2" (5.1cm) fully glazed trapway. Toilet shall include color match trip lever. Toilet shall be less seat and supply. Toilet shall be ADA compliant (PF1403T) with 17" high bowl.

	PF5114HE /1400T	PF5114HE /1401T	PF5114HE /1403T
A	30-1/2"	32-1/8"	32-1/8"
E	9-3/4"	9-3/4"	9-3/4"
F	14"	14"	14"
G	15-3/4"	15-3/4"	15-3/4"

	PF5110HE /1400T	PF5110HE /1401T	PF5110HE /1403T
A	26-1/2"	28-1/8"	28-1/8"
E	6-1/4"	6-1/4"	6-1/4"
F	10"	10"	10"
G	17-1/2"	17-1/2"	17-1/2"

	PF5112HE /1400T	PF5112HE /1401T	PF5112HE /1403T
A	28-1/2"	30-1/8"	31-1/8"
B	16-1/2"	18-1/2"	18-1/2"
C	15"	15"	17"
D	29-3/4"	29-3/4"	31-3/4"
E	8-1/2"	8-1/2"	8-1/2"
F	12"	12"	12"
G	15-3/4"	15-3/4"	15-3/4"

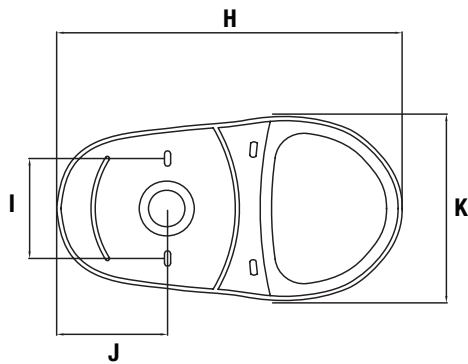

Footprint

	RF	EL	ADA
	PF1400T	PF1401T	PF1403T
H	18-1/2"	18-1/2"	18-1/2"
I	6"	6"	6"
J	6-1/8"	6-1/2"	6-1/2"
K	9"	9"	9"

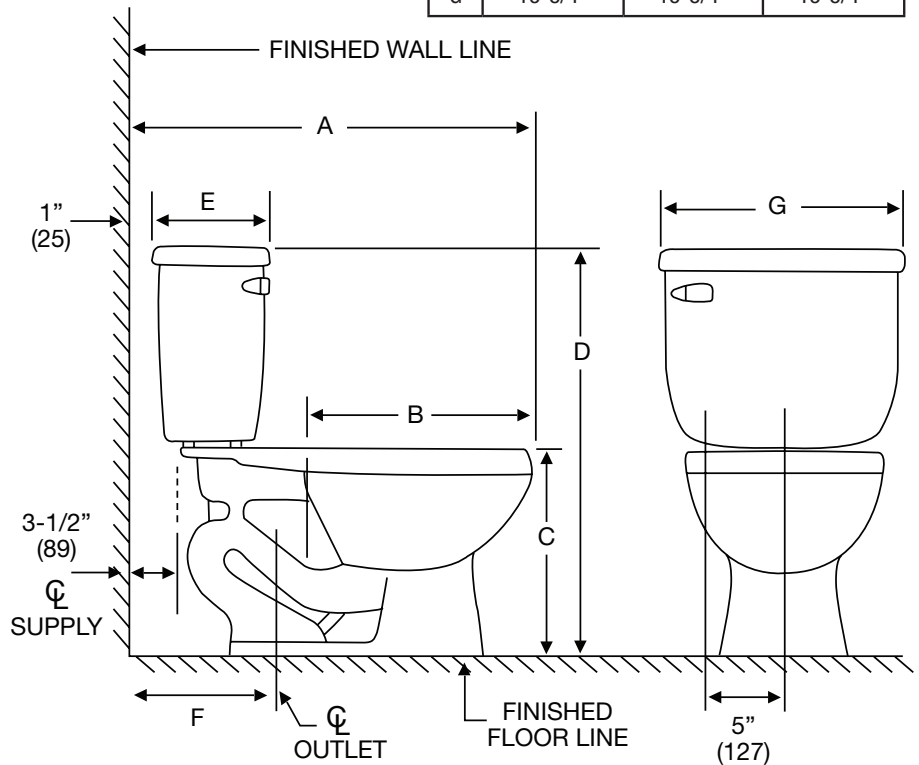

Warranty and Codes:

This product comes complete with installation, operating, care and maintenance instructions. All PROFLO fixtures carry a 1- year limited warranty. This product meets or exceeds ASME/ANSI A112.19.2M. In an effort to continually improve our products, we will make design changes from time to time. We reserve the right to ship newly designed product to fill any order unless we agree in writing to do otherwise.

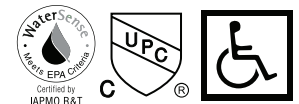

Distributed Exclusively by Ferguson and Wolseley Canada

PF7611S series

Single Handle Tub and Shower Trim Kit



Product Features

- Metal lever handle
- Brass shower arm and stainless steel flange
- Single function showerhead with easy-clean rubber nozzles
- Slip-fit spout for 1/2" copper pipe
- 100% factory pressure tested
- 1.75 gpm flow showerhead
- cUPC/IAPMO Listed
- ADA Compliant
- WaterSense Certified
- Use with ACCUFIT PF3001 series valve



PF7611SCP

Model Numbers

PF7611SCP	Polished chrome
PF7611SBN	Brushed nickel
PF7611SORB	Oil rubbed bronze

Available Parts

PFS40	6" shower arm CP
PFS42	Shower arm flange CP
PF1096	Slip fit tub spout CP

Product Specifications

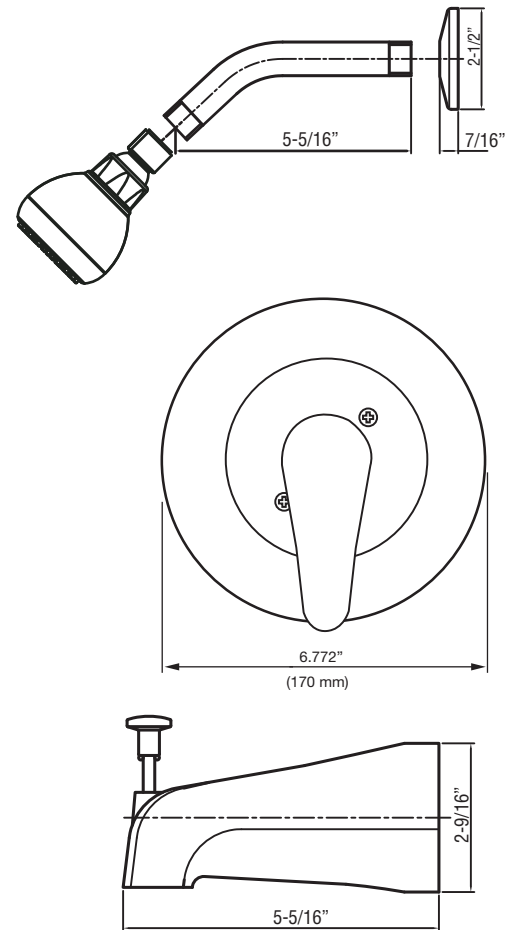

Warranty and Codes

This product comes complete with installation, operating, care and maintenance instructions. This PROFLO faucet carries a limited lifetime warranty when installed in residential applications. The warranty is five years in commercial applications. This product meets ASME: A112.18.1.



Distributed Exclusively by Ferguson and Wolseley Canada

PF3001



ACCUFIT Pressure Balance Tub and Shower Valve with Stops

Product Features

- Pressure balance valve with integral stops
- One-piece cartridge design for ease of maintenance
- Ceramic disc valve cartridge
- Back-to-back capability
- Cast bronze valve body
- Optional air test cap available
- Adjustable temperature limit stop
- 6.3 GPM flow rate at 60 psi
- IAPMO Approved
- Quick remove plaster guard
- Easy mounting brackets
- Meets or exceeds ASSE 1016-P standards (anti-scald)



PF3001

Model Numbers

- PF3001** Ceramic disc tub & shower valve with stops 1/2" MIP & SWT
- PF3001C** Ceramic disc tub & shower valve with stops CPVC connection
- PF3001F** Ceramic disc tub & shower valve with stops FIP
- PF3001P** Ceramic disc tub & shower valve with stops PEX crimp connector

Product Specifications

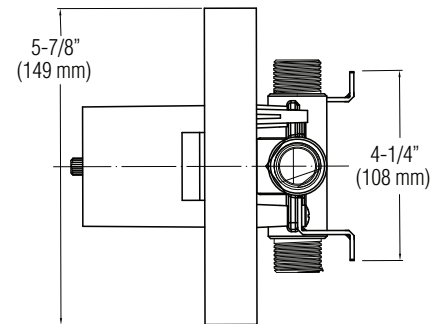
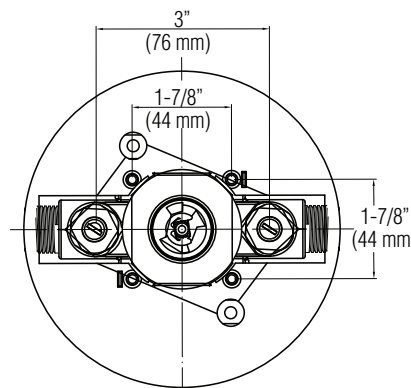

Parts Available

- ACF3001CRT** Replacement cartridge assembly
- ACF3001AIR** Air test cap
- ACF3001GRD** Plaster guard
- ACF3001EXTCP** Deep rough extension kit CP
- ACF3001EXTBN** Deep rough extension kit BN
- ACF3001EXTORB** Deep rough extension kit ORB

	A (in)	A (mm)
PF3001	5-1/2	139
PF3001C	8-1/8	206
PF3001F	5-1/8	130
PF3001P	5-1/4	134

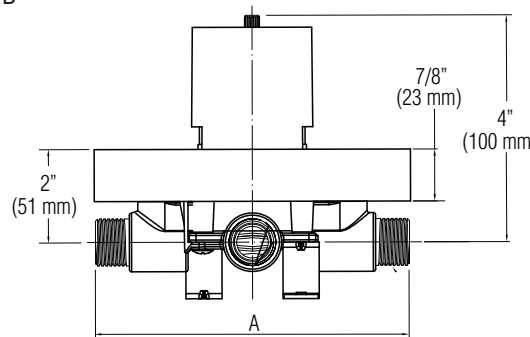

Rough-in depth
2" min.-3" max

Warranty and Codes

This product comes complete with installation, operating, care and maintenance instructions. This PROFLO faucet carries a limited lifetime warranty when installed in residential applications. The warranty is five years in commercial applications. This product meets ANSI: A112.18.1M and ASSE 1016-P





Features

- Durable swirl gloss finish.
- Backrest molded into bath.
- 15" (381 mm) bath depth (floor to top of threshold).
- 60" (1524 mm) x 30" (762 mm) x 15" (381 mm) finished dimensions.

Material

- Compression molded from our exclusive solid Vikrell® material.

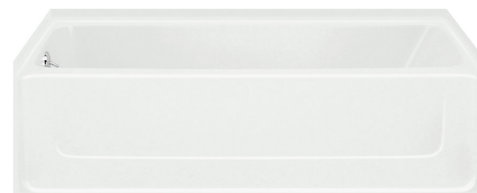

ADA

Codes/Standards

- CSA B45.5/IAPMO Z124
- ASTM E162
- ASTM E662
- Greenguard UL 2818 - Gold
- ADA
- ICC/ANSI A117.1
- HUD, UM Bulletin 73

Warranty – Bathing Fixtures (and) Kitchen and Utility Sinks Made of Solid Vikrell® Material

See website for detailed warranty information.

Available Color/Finishes

Color tiles intended for reference only.

Color	Code	Description
	0	White
	96	KOHLER Biscuit

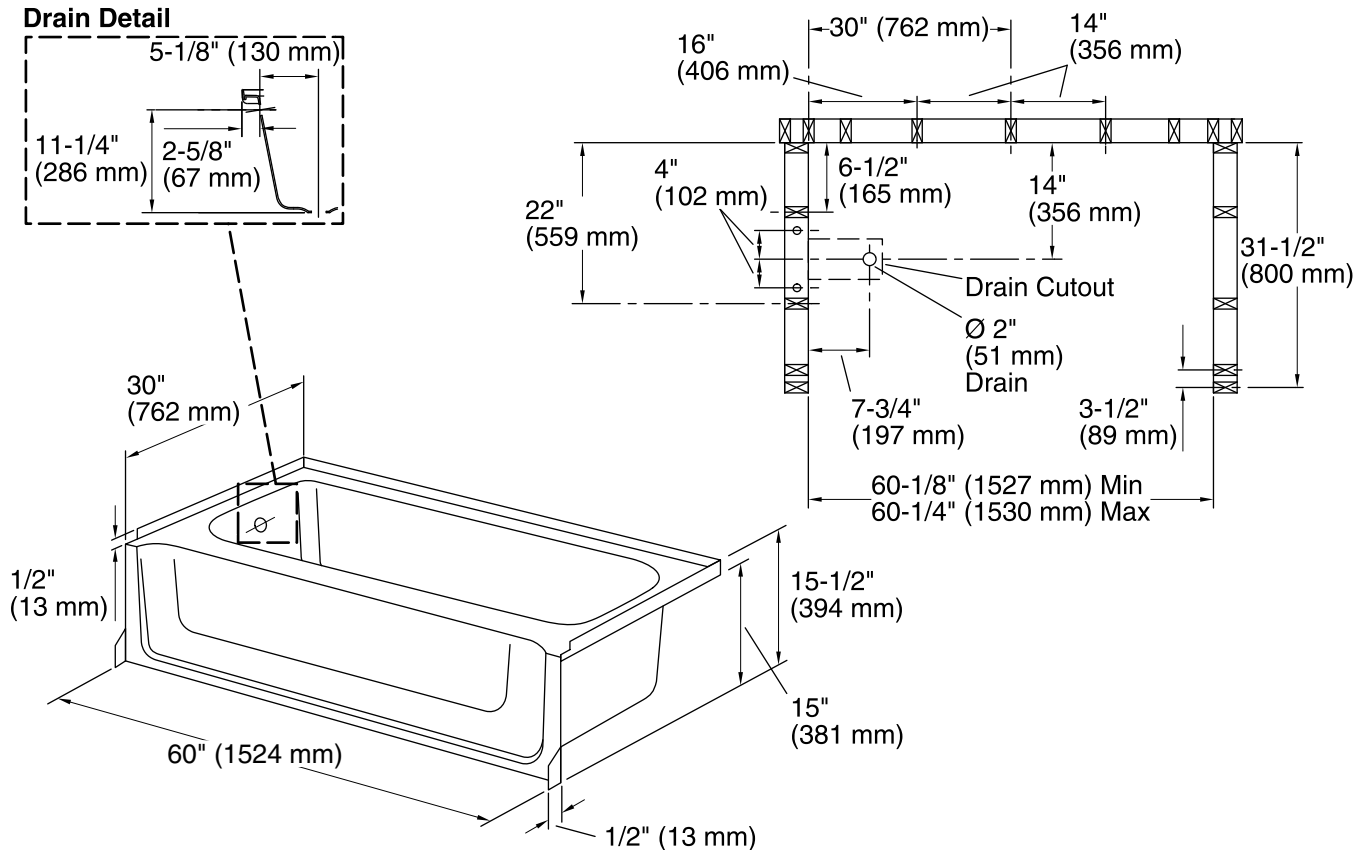

Technical Information

All product dimensions are nominal.

Installation:	3-Wall Alcove
Drain location:	Left
Basin area, bottom:	48" x 21" (1219 mm x 533 mm)
Basin area, top:	55" x 23" (1397 mm x 584 mm)
Weight:	51.835 lbs (23.5 kg)
Water depth:	9-3/8" (238 mm)
Water capacity:	44 gal (166.6 L)
Minimum flat for door:	2-1/4" (57 mm)
Maximum door height:	57" (1448 mm)
Maximum door width:	57-1/2" (1461 mm)

Notes

Install this product according to the installation instructions.

Studs should be positioned roughly as shown.

Double studding is recommended for pivot shower door installations.

ADA compliant when installed to the specific requirements of these regulations.



COMMERCIAL-GRADE

RESIDENTIAL ELECTRIC WATER HEATERS

PROLINE® COMMERCIAL-GRADE RESIDENTIAL

ENHANCED HEATING ELEMENTS

- Dual 4500 watt elements for faster recovery and reliable operation.*
- Incoly stainless steel lower element lasts longer than a standard copper element.

SELF-CLEANING DIP TUBE

- Helps reduce lime and sediment buildup, maximizes hot water output. Made from long-lasting PEX cross-linked polymer (self-cleaning design is not used on lowboy models).

HIGH ENERGY FACTORS

- Eco-friendly non-CFC foam insulation, heat traps and other features combine to yield a higher Energy Factor that maximizes savings on operating costs.

COREGARD™ ANODE ROD

- Our anode rods have a stainless steel core that extends the life of the anode rod allowing superior tank protection far longer than standard anode rods.

BLUE DIAMOND® GLASS COATING

- Provides superior corrosion resistance compared to industry-standard glass lining.

ENHANCED-FLOW BRASS DRAIN VALVE

- Our residential water heaters have a solid brass, tamper resistant, enhanced-flow, ball type, drain valve.
- Uses a standard female hose fitting that allows for fast and easy draining during maintenance.
- Designed for easy operation, this valve includes an integral screwdriver slot that features a ¼ turn (open/close) radius, which not only permits full straight-through water flow but also a quick and positive shut off.

*Model EN6 20 SOLS has a single element.

CODE COMPLIANCE

- Meets UBC and ICC National Codes and listed with CEC.
- Complies with the Federal Energy Conservation Standards effective April 16, 2015, in accordance with the Energy Policy and Conservation Act (EPCA), as amended.

APPROVED FOR MANUFACTURED HOUSING

- All residential electric water heaters are compliant with HUD Standards for mobile homes/manufactured housing.

CERTIFIED TO UL 174 FOR HOUSEHOLD ELECTRIC WATER HEATERS

CSA CERTIFIED AND ASME RATED T&P RELIEF VALVE

DESIGN-LISTED BY UNDERWRITERS LABORATORIES

- Certified at 300 psi test pressure and 150 psi working pressure.
- Listed according to UL 174 standards governing storage tank-type electric water heaters.

6-YEAR LIMITED TANK AND PARTS WARRANTY

- For complete information, consult written warranty or go to statewaterheaters.com.



SOLID. STATE.



COMMERCIAL-GRADE

RESIDENTIAL ELECTRIC WATER HEATERS

Model Number	Gallon Capacity	First Hour Rating Gallon	Energy Factor	Recovery @ 90°F Rise Gallon Per Hour	Element Wattage 240V		Dimensions in Inches			Approx. Shipping Weight (lbs)
					Standard	Maximum	A	B	C	
Tall Models										
†ENG 30 DORT	30	47	0.95	21	4500	6000	46-1/2	39-1/2	19	95
†ENG 40 DORT	40	50	0.95	21	4500	6000	61-1/4	53-1/4	18	118
†ENG 50 DORT	50	73	0.95	21	4500	6000	60-1/2	51-1/4	20-1/2	125
†ENG 55 DORT	55	76	0.94	21	4500	6000	56-1/2	48-1/2	24	145
Short Models										
ENG 30 DOBS*	30	48	0.95	21	4500	6000	39	30-1/2	20	95
†ENG 30 DORS	30	49	0.95	21	4500	6000	39-3/4	30-1/2	22	94
†ENG 40 DORS	40	55	0.95	21	4500	6000	49-3/4	40-3/4	20-1/2	109
†ENG 50 DORS	50	62	0.95	21	4500	6000	49-1/4	40-3/8	23	161
Lowboy Top Connect Models										
ENG 20 SOLS	19.5	N/A	N/A	21	4500	6000	30	21-1/4	20	65
†ENG 30 DOLBS*	28	40	0.95	21	4500	6000	30	21-3/4	20	90
†ENG 30 DOLS	28	42	0.95	21	4500	6000	30	21-3/4	22	115
†ENG 36 DOLS	36	46	0.95	21	4500	6000	32	24	24	118
†ENG 40 DOLBS*	38	44	0.95	21	4500	6000	32	24	23	118
†ENG 50 DOLBS*	48	57	0.95	21	4500	6000	34	25	26-1/2	172
†ENG 50 DOLS	51	51	0.94	21	4500	6000	36	25	26-1/2	172

Male 3/4" water connections on 8" center.

*Models ship with supplied insulation blanket.

†For 10-year tank and 6-year parts limited warranty, change "N6" to "SX" in select models and "R" to "N" in tall and short model number (example: ESX 40 DONT).

ENG 20 SOLS is a single element configuration only

Optional top T&P location #2 is used on ENG 50 DORT, ENG 55 DORT, ENG 40 DORS and ENG 50 DORS.

Optional top T&P location #3 is used on ENG 50 DOLBS, ENG 30 DOLBS, ENG 30 DOLS, ENG 40 DOLBS, ENG 50 DOLS, and ENG 36 DOLS.

Top T&P is not available on the 10 year lowboy models.

Dimensions and specifications subject to change without notice in accordance with our policy of continuous product improvement.

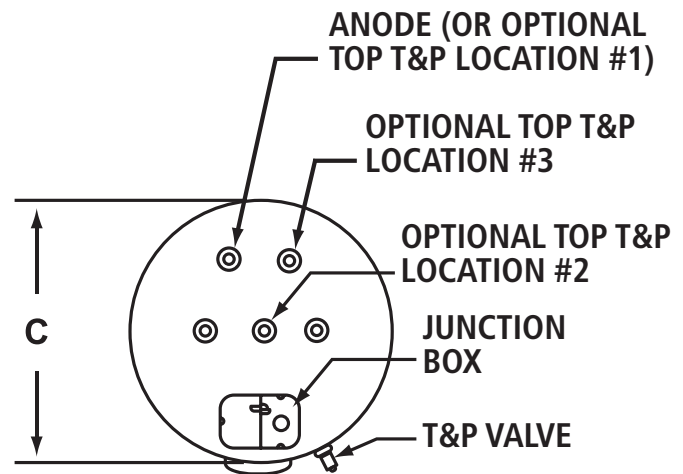
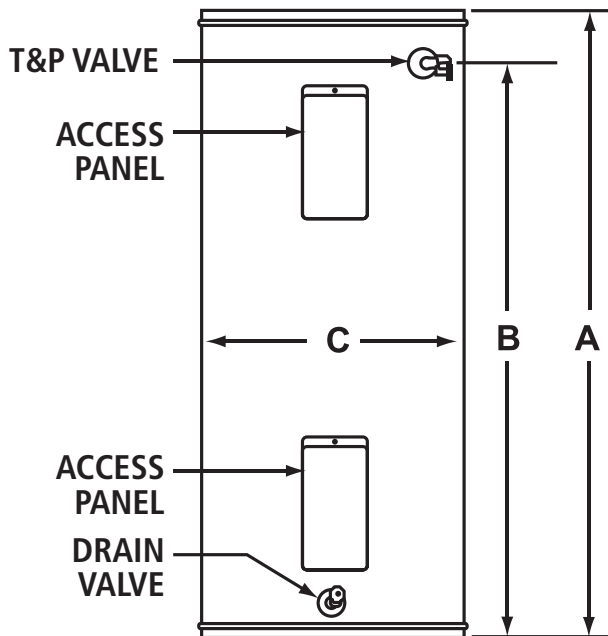

FOR MORE INFORMATION CONTACT: STATE WATER HEATERS 500 TENNESSEE WALTZ PARKWAY, ASHLAND CITY, TN 37015 • 800-365-0024 TOLL-FREE USA • STATEWATERHEATERS.COM