



SPECIFICATIONS FOR:

BAKER HEIGHTS REDEVELOPMENT

SEATTLE, WASHINGTON

HUD SUBMITTAL

GGLO PROJECT NO. 2017033.00

© 2020 GGLO

VOLUME 1 – DIVISIONS 00-14

22 JUNE 2020

DOCUMENT 000103
PROJECT DIRECTORY

PROJECT

Baker Heights Redevelopment
BUILDING A - 2710 14th St. BUILDING B - 2715 15th St.
BUILDING C - 2815 15th St. BUILDING D - 2810 14th St.
Everett, WA

OWNER

Everett Housing Legacy LLLP
3107 Colby Avenue
Everett, WA 98201
Telephone: 425.258.9222
Contact: Steve Yago
Email: stevey@evha.org

ARCHITECT

GGLO
1301 First Avenue, Suite 301
Seattle, WA 98101
Telephone: 206.467.5828
Contact: Scott Schreffler
Direct: 206 920.5560
Mobile: 425.870.2656
Email: sschreffler@gglo.com

CIVIL ENGINEER

KPFF
1601 5th Ave Suite 1600
Seattle, WA 98101
Telephone: 206.622.5822
Project Manager: Alberto G. Cisneros, PE
Direct: 206.926.0519
Email: alberto.cisneros@kpff.com

INTERIOR DESIGN

GGLO
1301 First Avenue, Suite 301
Seattle, WA 98101
Telephone: 206.467.5828
Contact: George Valdez
Direct: 206 902.5612
Mobile: 206.519.8655
Email: gvaldez@gglo.com

STRUCTURAL ENGINEER

Michael Nouwens Structural Consultants
P.O. Box 921
Edmonds, WA 98020
Telephone: 206.546.8446
Facsimile: 206.546.6335
Contact: Michael Nouwens, PE
Email: michael@nouwens-structural.com

MEP ENGINEERS

Glumac.
1601 Fifth Avenue, Suite 2210
Seattle, WA 98101
Telephone: 206.262.1010
Project Manager: DeNayne Glenn, PE
Email: DGlenn@glumac.com

LANDSCAPE ARCHITECT

GGLO
1301 First Avenue, Suite 301
Seattle, WA 98101
Telephone: 206.467.5828
Project Manager: Marieke Lacasse
Direct: 206 920.5614
Mobile: 206.523.2375
Email: mlacasse@gglo.com

HARDWARE CONSULTANT

dormakaba USA Inc.
8741 Salvada Avenue
Las Vegas, NV 89148
Telephone: (702) 941-7766
Mobile: (949) 444-4322
Contact: Patricia Smith, AHC, CDT, CSI
Email: patricia.smith@dormakaba.com

END OF DOCUMENT 000103

DOCUMENT 000110

TABLE OF CONTENTS – VOLUME. 1

000000 COVER PAGE

DIVISION 00 – PROCUREMENT AND CONTRACTING REQUIREMENTS

INTRODUCTORY INFORMATION

000103 PROJECT DIRECTORY

000110 TABLE OF CONTENTS

PROCUREMENT REQUIREMENTS

003132 GEOTECHNICAL DATA

CONTRACTING REQUIREMENTS

005433 DIGITAL DATA LICENSING AGREEMENT

006313 REQUEST FOR INTERPRETATION FORM

006325 REQUEST FOR SUBSTITUTION FORM

007313 SUPPLEMENTARY CONDITIONS FORMS

HUD 92554 SUPPLEMENTARY CONDITIONS.

HUD SPECIAL CONDITIONS.

DAVIS-BACON ACT WD # WA20200094 3.6.2020.

HUD 92442M CONTRACT FORM.

HUD 92452 PERFORMANCE BOND.

HUD 2328 COST BREAKDOWN FORM.

HUD 92437 REQUEST FOR CHANGES.

HUD 92448 CONTRACTOR PAYMENT REQUEST.

HUD 92441M BUILDING LOAN AGREEMENT.

DIVISION 01 – GENERAL REQUIREMENTS

011100 SUMMARY OF WORK

012500 SUBSTITUTION PROCEDURES

012600 CONTRACT MODIFICATION PROCEDURES

012900 PAYMENT PROCEDURES

013100 PROJECT MANAGEMENT AND COORDINATION

013200 CONSTRUCTION PROGRESS DOCUMENTATION

013233 PHOTOGRAPHIC DOCUMENTATION

013300 SUBMITTAL PROCEDURES

013573 DELEGATED DESIGN PROCEDURES

014000 QUALITY REQUIREMENTS

014200 REFERENCES

014339 MOCKUPS

015000 TEMPORARY FACILITIES AND CONTROLS

016000 PRODUCT REQUIREMENTS

017300 EXECUTION

017419 CONSTRUCTION WASTE MANAGEMENT AND DISPOSAL

017700 CLOSEOUT PROCEDURES

017823 OPERATION AND MAINTENANCE DATA

017839	PROJECT RECORD DOCUMENTS
017900	DEMONSTRATION AND TRAINING
018113	EVERGREEN SUSTAINABLE DEVELOPMENT STANDARD (ESDS) EVERGREEN SUSTAINABLE DEVELOPMENT STANDARD V3.0 CHECKLIST
018316	EXTERIOR ENCLOSURE PERFORMANCE REQUIREMENTS
019113	GENERAL COMMISSIONING REQUIREMENTS

DIVISION 02 – EXISTING CONDITIONS

024100	DEMOLITION
--------	------------

DIVISION 03 – CONCRETE

033000	CAST-IN-PLACE CONCRETE
034500	PRECAST ARCHITECTURAL CONCRETE
035413	GYPSUM CEMENT UNDERLAYMENT

DIVISION 04 – MASONRY

042200	UNIT MASONRY
--------	--------------

DIVISION 05 – METALS

051200	STRUCTURAL STEEL FRAMING
055000	METAL FABRICATIONS
055213	PIPE AND TUBE RAILINGS
055313	BAR GRATINGS

DIVISION 06 – WOOD, PLASTICS, AND COMPOSITES

061000	ROUGH CARPENTRY
061600	SHEATHING
061753	SHOP FABRICATED WOOD TRUSSES
061800	GLUED-LAMINATED CONSTRUCTION
062023	INTERIOR FINISH CARPENTRY
064023	INTERIOR ARCHITECTURAL WOODWORK
064100	ARCHITECTURAL WOOD CASEWORK

DIVISION 07 – THERMAL AND MOISTURE PROTECTION

071700	BENTONITE WATERPROOFING
072100	THERMAL INSULATION
072119	FOAMED-IN-PLACE INSULATION
072500	WEATHER BARRIERS
073013	ROOFING UNDERLAYMENTS
073113	ASPHALT SHINGLES
074113.16	STANDING-SEAM METAL ROOF PANELS
074646	FIBER-CEMENT SIDING
075423	THERMOPLASTIC-POLYOLEFIN (TPO) ROOFING
076200	SHEET METAL FLASHING AND TRIM
076500	FLEXIBLE FLASHING
078400	FIRESTOPPING

079200 JOINT SEALANTS
079219 ACOUSTICAL JOINT SEALANTS

DIVISION 08 – OPENINGS

081113 HOLLOW METAL DOORS AND FRAMES
081416 FLUSH WOOD DOORS
083113 ACCESS DOORS AND FRAMES
084113 ALUMINUM-FRAMED ENTRANCES AND STOREFRONTS
085313 VINYL WINDOWS
087100 DOOR HARDWARE
088000 GLAZING
088300 MIRRORS
089119 FIXED LOUVERS

DIVISION 09 – FINISHES

092116 GYPSUM BOARD SHAFT WALL ASSEMBLIES
092900 GYPSUM BOARD
093013 CERAMIC TILING
096513 RESILIENT BASE AND ACCESSORIES
096519 RESILIENT TILE FLOORING
096813 TILE CARPETING
099000 PAINTING AND COATING
099600 HIGH PERFORMANCE COATINGS
099623 GRAFFITI-RESISTANT COATINGS

DIVISION 10 – SPECIALTIES

101423 PANEL SIGNAGE
101423.16 ROOM-IDENTIFICATION PANEL SIGNAGE
102239 FOLDING PANEL PARTITIONS
102813 TOILET AND BATH ACCESSORIES
104413 FIRE PROTECTION CABINETS
104416 FIRE EXTINGUISHERS
105500 USPS-DELIVERY POSTAL SPECIALTIES
105700 WARDROBE AND CLOSET SPECIALTIES

DIVISION 11 – EQUIPMENT

113100 RESIDENTIAL APPLIANCES
116800 PLAY FIELD EQUIPMENT AND STRUCTURES

DIVISION 12 – FURNISHINGS

120513 FABRICS
122116 VERTICAL LOUVER BLINDS
123530 RESIDENTIAL CASEWORK
123623.13 PLASTIC-LAMINATE-CLAD COUNTERTOPS
123661.19 QUARTZ AGGLOMERATE COUNTERTOPS

DIVISION 13 – SPECIAL CONSTRUCTION

134816 MANUFACTURED SOUND CONTROL COMPONENTS

DIVISION 14 – CONVEYING EQUIPMENT

142400 HYDRAULIC ELEVATORS

APPENDICES

APPENDIX A LIGHT FIXTURE PRODUCT DATA

APPENDIX B OWNER HAZARDOUS MATERIAL INFORMATION

DOCUMENT 000110

TABLE OF CONTENTS – VOLUME. 2

DIVISION 21 – FIRE SUPPRESSION

210500	BASIC FIRE PROTECTION MATERIALS AND METHODS
211000	FIRE PROTECTION

DIVISION 22 – PLUMBING

220500	BASIC PLUMBING MATERIALS AND METHODS
220548	VIBRATION ISOLATION FOR PLUMBING EQUIPMENT
220549	SEISMIC RESTRAINT FOR PLUMBING PIPING AND EQUIPMENT
220593	PLUMBING TESTING, ADJUSTING AND BALANCING
220700	PLUMBING INSULATION
221000	PLUMBING PIPING, VALVES AND SPECIALTIES
221117	DOMESTIC PEX WATER PIPING
221123	PUMPS AND SPECIALTIES
223400	DOMESTIC HOT WATER HEATING EQUIPMENT
224000	PLUMBING FIXTURES

DIVISION 23 – HEATING VENTILATING AND COOLING

230500	BASIC HVAC MATERIALS AND METHODS
230530	DUCT AND COIL CLEANING
230548	VIBRATION ISOLATION FOR PIPING DUCTWORK AND EQUIPMENT
230593	TESTING ADJUSTING AND BALANCING
230716	EQUIPMENT INSULATION
230719	HVAC PIPING INSULATION
230900	BUILDING AUTOMATION SYSTEM (BAS) CONTROLS
232300	REFRIGERANT PIPING SYSTEMS
233113	AIR DISTRIBUTION
233415	UNIT VENTILATOR
233416	INLINE FANS
238158	VRF-VRV SYSTEMS
238219	FAN COIL UNITS
238230	HEATING UNITS

DIVISION 25 – INTEGRATED AUTOMATION (NOT USED)

DIVISION 26 – ELECTRICAL

260500	BASIC ELECTRICAL REQUIREMENTS
260519	LOW-VOLTAGE ELECTRICAL POWER CONDUCTORS AND CABLES
260526	GROUNDING AND BONDING FOR ELECTRICAL SYSTEMS
260529	HANGERS AND SUPPORTS FOR ELECTRICAL SYSTEMS
260533	RACEWAYS AND BOXES FOR ELECTRICAL SYSTEMS
260543	UNDERGROUND DUCTS AND RACEWAYS FOR ELECTRICAL SYSTEMS
260544	SLEEVES AND SLEEVE SEALS FOR ELECTRICAL RACEWAYS AND CABLING
260548	SEISMIC CONTROLS FOR ELECTRICAL SYSTEMS
260553	IDENTIFICATION FOR ELECTRICAL SYSTEMS

260572	SHORT-CIRCUIT STUDIES
260573	COORDINATION STUDIES
260574	ARC-FLASH HAZARD ANALYSIS
260913	ELECTRICAL POWER MONITORING AND CONTROL
260923	LIGHTING CONTROL DEVICES
260936	MODULAR DIMMING CONTROLS
262413	SWITCHBOARDS
262416	PANELBOARDS
262713	ELECTRICITY METERING
262726	WIRING DEVICES
262813	FUSES
262816	ENCLOSED SWITCHES AND CIRCUIT BREAKERS
263100	PHOTOVOLTAIC COLLECTORS
264313	SURGE PROTECTION FOR LOW-VOLTAGE ELECTRICAL POWER CIRCUITS
265119	LED INTERIOR LIGHTING
265213	EMERGENCY AND EXIT LIGHTING
265613	LIGHTING POLES AND STANDARDS
265619	LED EXTERIOR LIGHTING

DIVISION 27 – COMMUNICATIONS

270000	GENERAL PROVISIONS FOR COMM SYSTEMS
270526	GROUNDING AND BONDING FOR COMMUNICATION SYSTEMS
271323	COMMUNICATIONS OPTICAL FIBER BACKBONE CABLING
271513	COMMUNICATIONS COPPER HORIZONTAL CABLING

DIVISION 28 – ELECTRICAL SAFETY AND SECURITY

DIVISION 31 – EARTHWORK

310000	EARTHWORK
311100	CLEARING AND GRUBBING

DIVISION 32 – EXTERIOR IMPROVEMENTS

321216	ASPHALT CONCRETE PAVEMENT
321316	DECORATIVE CONCRETE PAVING
321373	CONCRETE PAVING JOINT SEALANTS
321400	UNIT PAVING
321613	CEMENT CONCRETE PAVING
321723	PAVEMENT MARKINGS AND SIGNAGE
321816.13	PLAYGROUND PROTECTIVE SURFACING
323300	SITE FURNISHINGS
323313	SITE BICYCLE RACKS AND LOCKERS
328400	PLANTING IRRIGATION
329113	SOIL PREPARATION
329200	TURF AND GRASSES
329300	PLANTS
329313	MANUFACTURED METAL BOLLARDS

DIVISION 33 – UTILITIES

331100	WATER DISTRIBUTION
333000	SANITARY SEWERS
334000	STORM DRAINAGE
334616	SUBDRAIN SYSTEM

END OF DOCUMENT 000110

DOCUMENT 003132
GEOTECHNICAL DATA

1.1 DOCUMENT INCLUDES

- A. Information made available to Bidders is for reference only.
 - 1. Geotechnical data.
 - 2. Addendum letter.
 - 3. Stormwater site plan.

1.2 USE OF INFORMATION

- A. Bidders are encouraged to review available Project geotechnical data prior to submitting a Bid, and to obtain additional information if Bidder desires.
- B. Existing **[soil-boring data] [and] [geotechnical investigation report]** are available for viewing at the offices of Architect and Owner.
- C. This Document, with its referenced attachments, is part of Procurement and Contracting Requirements for Project. They provide Owner's information for Bidders' convenience and are intended to supplement rather than serve in lieu of Bidders' own investigations. They are made available for Bidders' convenience and information. This Document and its attachments are not part of Contract Documents.
- D. Because subsurface conditions indicated by the soil borings are a sampling in relation to the entire construction area, and for other reasons, the Owner, the Architect, the Architect's consultants, and the firm reporting the subsurface conditions do not warranty the conditions below the depths of the borings or that the strata logged from the borings are necessarily typical of the entire site. Any party using the information described in the soil borings and geotechnical report shall accept full responsibility for its use.
- E. Extra Payment Limitations: No consideration for extra payment will be given for conditions occurring that could have been anticipated from soil information. If conditions occur resulting in extra Work that could not have been anticipated or reasonably inferred from this information, Conditions of the Contract for changes in Work will apply.

1.3 GEOTECHNICAL DATA

- A. Geotechnical investigation report prepared for this Project, referenced as follows:
 - 1. Testing agency's project number: File No. 21288-002-00
 - 2. Date of Survey: October 30, 2019
 - 3. Soil boring data prepared by:
 - GeoEngineers
 - 17425 NE Union Hill Road, Suite 250
 - Redmond, WA 98052
 - Telephone: 425.861.6000
- B. Geotechnical Report Addendum Letter, referenced as follows:
 - 1. Addendum Letter No. 1
 - 2. Testing agency's project number: File No. 21288-002-00
 - 3. Date of Addendum Letter: April 22, 2020
 - GeoEngineers
 - 17425 NE Union Hill Road, Suite 250
 - Redmond, WA 98052
 - Telephone: 425.861.6000

1.4 STORMWATER DATA

- A. Stormwater Site Plan, referenced as follows:
 - 1. Engineer's project number: 1700658
 - 2. Date of Site Plan: June 2020

KPF Consulting Engineers
1601 Fifth Avenue, Suite 1600
Seattle, WA 98101
Telephone: 206.622.5822
- B. The opinions expressed in this report are those of a geotechnical engineer and represent interpretations of subsoil conditions, tests, and results of analyses conducted by a geotechnical engineer. Owner is not responsible for interpretations or conclusions drawn from the data.
- C. Any party using information described in the geotechnical report shall make additional test borings and conduct other exploratory operations that may be required to determine the character of subsurface materials that may be encountered.

END OF DOCUMENT 003132

DOCUMENT 005433

DIGITAL DATA LICENSING AGREEMENT

Agreement made as of the _____ day of _____ in the year _____
(In words, indicate day, month, and year.)

Between the Party transmitting Digital Data ("Transmitting Party"):

GGLO
1301 First Avenue, Suite 301
Seattle, WA 98101

Attention: Scott Schreffler
Telephone: 206.902.5560
Email: SSchreffler@GGLO.com

And the Party receiving Digital Data ("Receiving Party"):

Company: _____
Address: _____
City, State, Zip: _____
Contact: _____
Telephone: _____
Email: _____

For the following Project:

Project: Baker Heights Redevelopment Project No.: 2017033.00
Address: 2800 and 2850 14th Street
2825 and 2875 15th Street
Everett, WA 98201

TERMS

The purpose of this Agreement is to grant a license from Transmitting Party to Receiving Party for Receiving Party's use of Digital Data on Project, and to set forth license terms.

This Agreement is the entire and integrated agreement between the Parties. Except as specifically set forth herein, this Agreement does not create any other contractual relationship between the Parties.

For purposes of this Agreement, the term Digital Data is defined to include only those items identified in "DIGITAL DATA" Article below.

Confidential Digital Data is defined as Digital Data containing confidential or business proprietary information that Transmitting Party designates and clearly marks as "confidential."

TRANSMISSION OF DIGITAL DATA

Transmitting Party grants to Receiving Party a nonexclusive limited license to use Digital Data identified in "DIGITAL DATA" Article below solely and exclusively to perform services for, or construction of, the Project in accordance with the terms and conditions set forth in this Agreement.

Transmission of Digital Data constitutes a warranty by Transmitting Party to Receiving Party that Transmitting Party is copyright owner of Digital Data, or otherwise has permission to transmit Digital Data to Receiving Party for its use on the Project in accordance with the terms and conditions of this Agreement.

If Transmitting Party transmits Confidential Digital Data, transmission of such Confidential Digital Data constitutes a warranty to Receiving Party that Transmitting Party is authorized to transmit Confidential Digital Data. If Receiving Party receives Confidential Digital Data, Receiving Party shall keep Confidential Digital Data strictly confidential and shall not disclose it to any other person or entity except as set forth herein.

Receiving Party may disclose Confidential Digital Data as required by law or court order, including a subpoena or other form of compulsory legal process issued by a court or governmental entity. Receiving Party may also disclose Confidential Digital Data to its employees, consultants, or contractors in order to perform services or work solely and exclusively for Project, provided those employees, consultants, and contractors are subject to restrictions on disclosure and use of Confidential Digital Data as set forth in this Agreement.

Transmitting Party retains its rights in Digital Data. By transmitting Digital Data, Transmitting Party does not grant to Receiving Party an assignment of those rights; nor does Transmitting Party convey to Receiving Party any right in software used to generate the Digital Data.

To the fullest extent permitted by law, Receiving Party shall indemnify, hold harmless, and defend Transmitting Party, its employees, its consultants, and Owner of Project indicated above, from and against claims arising from or related to Receiving Party's modification to, or unlicensed use of, Digital Data.

LICENSING CONDITIONS

The Parties agree to the following conditions on limited license granted in "TRANSMISSION OF DIGITAL DATA" Article above.

1. The documents included in Digital Data files are Transmitting Party's instruments of service. Transmitting Party does not waive any common law or statutory rights, including copyright.
2. Information in Digital Data files does not supplement, modify, or replace Contract Documents (as defined by Contract for Construction). There may be discrepancies between information in Digital Data files and Contract Documents. Rely only on Contract Documents as representing Contract requirements.
3. Digital Data files are provided in an "as is" condition. No warranties of any kind, including implied warranty of merchantability or fitness for a particular purpose, are granted.
4. Transmitting these Digital Data files does not create any duty to any person or entity.
5. Digital Data files shall not be used for any purpose related to any project other than Project identified above.
6. It is Receiving Party's responsibility to coordinate differences between Digital Data files and Contract Documents.

DIGITAL DATA

Digital Data was prepared using the following software: Revit (rvt) _____ Ver.: _____

Transmitting Party will provide the following Digital Data files, dated as of the particular transmission, to Receiving Party for information or other specified purposes only:

Floor plans _____

Reflected ceiling plans _____

Deliver Digital Data via Architect's Project Information Management System as specified in Section 013100 – Project Management and Coordination.

AUTHORIZED ACCEPTANCE

Transmitting Party (Signature)

Receiving Party (Signature)

(Print Name and Title)

(Print Name and Title)

END OF DOCUMENT 005433

DOCUMENT 006313
REQUEST FOR INTERPRETATION FORM

Project: Baker Heights Redevelopment
Project No.: 2017033.00

Date: _____
Spec Section No.: _____

To:

GGLO
1301 First Avenue, Suite 301
Seattle, WA 98101

Attention: Scott Schreffler
Telephone: 206.902.5560
Email: SSchreffler@GGLO.com

Contractor: _____
Requested by: _____
Phone: _____
Email: _____

Related Section and Paragraph No.: _____
Related Sheet and Detail No.: _____

Contractor's Inquiry: _____

Contractor's Recommended Solution: _____

Attachments: _____
Architect's Response Requested By: _____

Architect's Response: _____

Signed: _____ Date: _____
Attachments: _____

END OF DOCUMENT 006313

DOCUMENT 006325
REQUEST FOR SUBSTITUTION FORM

Project: Baker Heights Redevelopment
Project No.: 2017033.00

Date: _____
Spec Section No.: _____

To:

GGLO
1301 First Avenue, Suite 301
Seattle, WA 98101

Attention: Scott Schreffler
Telephone: 206.902.5560
Email: SSchreffler@GGLO.com

Contractor: _____
Requested by: _____
Phone: _____
Email: _____

Reason for not providing specified item: _____

Savings to Owner for accepting Substitution: _____

Specified Product/Fabrication Method

(List name/description; model no., manufacturer): _____

Required Information for **Specified** Product: Attached:

- | | |
|--|--|
| <input type="checkbox"/> Point by Point Comparative Product Data (<i>Required</i>) | <input type="checkbox"/> Fabrication Drawings |
| <input type="checkbox"/> Tests | <input type="checkbox"/> Samples (<i>Where Applicable</i>) |
| <input type="checkbox"/> Reports | |

Proposed Product/Fabrication Method

(List name/description; model no., manufacturer): _____

Required Information for **Proposed** Product: Attached:

- | | |
|--|--|
| <input type="checkbox"/> Point by Point Comparative Product Data (<i>Required</i>) | <input type="checkbox"/> Fabrication Drawings |
| <input type="checkbox"/> Tests | <input type="checkbox"/> Samples (<i>Where Applicable</i>) |
| <input type="checkbox"/> Reports | |

List of Related Changes/Modifications: _____

Differences between proposed substitution
and specified product: _____

Do proposed product/fabrication methods
affect other parts of Work? No Yes: Explain _____

Undersigned certifies:

- Proposed substitution has been fully investigated and determined to be equivalent or superior in all respects to specified product as utilized for this Project, except as noted herein.
- Qualifications of manufacturer, Installer, and other specified parties meet specified qualifications.
- Same special warranty will be furnished for proposed substitution as for specified product.
- Same maintenance service and source for replacement parts, as applicable, is available as that specified.
- Proposed substitution does not affect dimensions and functional clearances, except as noted herein.

Contractor:

Submitted by: _____

Signed: _____

Firm: _____

Telephone: _____ Email: _____

Architect:

Submitted by: _____

Signed: _____

Telephone: 206-340.9500 Email: _____

Accepted Accepted as Noted Not Accepted Received too Late

END OF DOCUMENT 006325

SECTION 007313
SUPPLEMENTARY CONDITIONS FORMS

1.1 SUPPLEMENTAL FORMS TO THE CONTRACT

- A. The following forms are required as part of the General Conditions for Project. Comply with requirements indicated within these forms, and submit them in compliance with HUD requirements.
1. HUD 92554 Supplementary Conditions.
 2. HUD Special Conditions.
 3. Davis-Bacon Act WD # WA20200094 3.6.2020.
 4. HUD 92442M Contract Form.
 5. HUD 92452 Performance Bond .
 6. HUD 2328 Cost Breakdown Form.
 7. HUD 92437 Request for Changes.
 8. HUD 92448 Contractor Payment Request.
 9. HUD 92441M Building Loan Agreement.

END OF DOCUMENT 007313

**SUPPLEMENTARY CONDITIONS
TO THE CONSTRUCTION
CONTRACT**

U.S. Department of Housing
and Urban Development
Office of Housing

OMB Approval No. 2502-0598
(Exp. 9/30/2021)

Public Reporting Burden for this collection of information is estimated to average 0.2 hours per response, including the time for reviewing instructions, searching existing data sources, gathering and maintaining the data needed, and completing and reviewing the collection of information. Response to this request for information is required in order to receive the benefits to be derived. This agency may not collect this information, and you are not required to complete this form unless it displays a currently valid OMB control number. While no assurance of confidentiality is pledged to respondents, HUD generally discloses this data only in response to a Freedom of Information Act request.

Warning: Federal law provides that anyone who knowingly or willfully submits (or causes to submit) a document containing any false, fictitious, misleading, or fraudulent statement/certification or entry may be criminally prosecuted and may incur civil administrative liability. Penalties upon conviction can include a fine and imprisonment, as provided pursuant to applicable law, which includes, but is not limited to, 18 U.S.C. 1001, 1010, 1012; 31 U.S.C. 3729, 3802, 24 C.F.R. Parts 25, 28 and 30, and 2 C.F.R. Parts 180 and 2424.

Article 1: Labor Standards

A. Applicability. The Project or program to which the construction work covered by this Contract pertains is being assisted or insured by the United States of America, and the following Federal Labor Standards Provisions are included in this Contract or related instrument pursuant to the provisions applicable to such Federal assistance or insurance. Any statute or regulation contained herein shall also include any subsequent amendment or successor statute or regulation. The terms of this Supplementary Conditions to the Construction Contract (HUD-92554M) takes precedence over all provisions of the "General Conditions of the Contract for Construction" (AIA Document A201) inconsistent with said Supplementary Conditions.

B. Minimum Wages. Pursuant to Section 212 of the National Housing Act, as amended, 12 U.S.C. 1715c, the minimum wage provisions contained in this paragraph B do not apply to those projects with Security Instruments insured under Section 221(h)(1) designed for less than 9 families and they do not apply to those projects with Security Instruments insured under either Section 220 or 233 designed for less than 12 families.

1. (i) All laborers and mechanics employed or working upon the site of the work (or under the United States Housing Act of 1937 or under the Housing Act of 1949 in the construction or development of the Project) shall be paid unconditionally and not less often than once a week, and without subsequent deduction or rebate on any account (except such payroll deductions as are permitted by regulations issued by the Secretary of Labor under the Copeland Act (29 CFR Part 3)), the full amount of wages and bona fide fringe benefits (or cash equivalents thereof) due at time of payment computed at rates not less than those contained in the wage determination of the Secretary of Labor which is attached hereto and made a part hereof, regardless of any contractual relationship which may be alleged to exist between the Contractor and such laborers and mechanics. Contributions made or costs reasonably anticipated for bona fide fringe benefits under Section 1 (b)(2) of the Davis-Bacon Act (40 U.S.C. 3141(2)(B)(ii)) on behalf of laborers or mechanics are considered wages paid to such laborers or

mechanics, subject to the provisions of 29 CFR 5.5(a)(1)(iv); also, regular contributions made or costs incurred for more than a weekly period (but not less often than quarterly) under plans, funds, or programs, which cover the particular weekly period, are deemed to be constructively made or incurred during such weekly period. Such laborers and mechanics shall be paid the appropriate wage rate and fringe benefits on the wage determination for the classification of work actually performed, without regard to skill, except as provided in 29 CFR 5.5(a)(4). Laborers or mechanics performing work in more than one classification may be compensated at the rate specified for each classification for the time actually worked therein: *Provided*, that the employer's payroll records accurately set forth the time spent in each classification in which work is performed. The wage determination (including any additional classification and wage rates conformed under 29 CFR 5.5(a)(1)(ii)) and the Davis-Bacon poster (WH-1321) shall be posted at all times by the Contractor and its subcontractors at the site of the work in a prominent and accessible place where it can be easily seen by the workers.

(ii) (a) Any class of laborers or mechanics that is not listed in the wage determination and that is to be employed under this Contract shall be classified in conformance with the wage determination. HUD shall approve an additional classification and wage rate and fringe benefits only when the following criteria have been met:

- (1) The work to be performed by the classification requested is not performed by a classification in the wage determination; and
- (2) The classification is utilized in the area by the construction industry; and
- (3) The proposed wage rate, including any bona fide fringe benefits, bears a reasonable relationship to the wage rates contained in the wage determination.

(b) If the Contractor and the laborers and mechanics to be employed in the classification (if known), or their representatives, and HUD or its designee agree on the classification and wage rate (including the amount designated for fringe benefits where appropriate), a report of the action taken shall be sent by HUD or its designee to the Administrator of the Wage and Hour Division, U.S. Department of Labor, Washington, D.C. 20210 (“**Administrator**”). The Administrator, or an authorized representative, shall approve, modify, or disapprove every additional classification action within thirty (30) days of receipt and so advise HUD or its designee or shall notify HUD or its designee within the thirty (30) day period that additional time is necessary.

(c) In the event the Contractor, the laborers or mechanics to be employed in the classification or their representatives and HUD or its designee do not agree on the proposed classification and wage rate (including the amount designated for fringe benefits, where appropriate), HUD or its designee shall refer the questions, including the views of all interested parties and the recommendation of HUD or its designee, to the Administrator for determination. The Administrator, or an authorized representative, shall issue a determination within thirty (30) days of receipt and so advise HUD or its

designee or shall notify HUD or its designee within the thirty (30) day period that additional time is necessary.

(d) The wage rate (including fringe benefits where appropriate) determined pursuant to subparagraphs B.1.(ii)(b) or (c) of this Article, shall be paid to all workers performing work in the classification under this Contract from the first day on which work is performed in the classification.

(iii) Whenever the minimum wage rate prescribed in the Contract for a class of laborers or mechanics includes a fringe benefit that is not expressed as an hourly rate, the Contractor shall either pay the benefit as stated in the wage determination or shall pay another bona fide fringe benefit or an hourly cash equivalent thereof.

(iv) If the Contractor does not make payments to a trustee or other third person, the Contractor may consider as part of the wages of any laborer or mechanic the amount of any costs reasonably anticipated in providing bona fide fringe benefits under a plan or program, *Provided*, That the Secretary of Labor has found, upon the written request of the Contractor, that the applicable standards of the Davis-Bacon Act have been met. The Secretary of Labor may require the Contractor to set aside in a separate account assets for the meeting of obligations under the plan or program.

2. Withholding. HUD or its designee shall upon its own action or upon written request of an authorized representative of the Department of Labor withhold or cause to be withheld from the Contractor under this Contract or any other Federal contract with the same prime contractor, or any other Federally-assisted contract subject to Davis-Bacon prevailing wage requirements, which is held by the same prime contractor, so much of the accrued payments or advances as may be considered necessary to pay laborers and mechanics, including apprentices, trainees and helpers, employed by the Contractor or any subcontractor the full amount of wages required by the Contract. In the event of failure to pay any laborer or mechanic, including any apprentice, trainee or helper, employed or working on the site of the work (or under the United States Housing Act of 1937 or under the Housing Act of 1949 in the construction or development of the Project), all or part of the wages required by the Contract, HUD or its designee may, after written notice to the Contractor, sponsor, applicant, or Owner, take such action as may be necessary to cause the suspension of any further payment, advance, or guarantee of funds until such violations have ceased. HUD or its designee may, after written notice to the Contractor, disburse such amounts withheld for and on account of the Contractor or subcontractor to the respective employees to whom they are due.

3. Payrolls, records, and certifications.

(i) Payrolls and basic records relating thereto shall be maintained by the Contractor during the course of the work and preserved for a period of three years thereafter for all laborers and mechanics working at the site of the work (or under the United States Housing Act of 1937, or under the Housing Act of 1949, in the construction or development of the Project). Such records shall contain the name, address, and social security number of each such worker, his or her correct

classification, hourly rates of wages paid (including rates of contributions or costs anticipated for bona fide fringe benefits or cash equivalents thereof of the types described in Section 1 (b)(2)(B) of the Davis-Bacon Act (40 U.S.C. 3141(2)(B)(ii))), daily and weekly number of hours worked, deductions made and actual wages paid. Whenever the Secretary of Labor has found under 29 CFR 5.5(a)(1)(iv) that the wages of any laborer or mechanic include the amount of any costs reasonably anticipated in providing benefits under a plan or program described in Section 1 (b)(2)(B) of the Davis-Bacon Act (40 U.S.C. 3141(2)(B)(ii)), the Contractor shall maintain records which show that the commitment to provide such benefits is enforceable, that the plan or program is financially responsible, and that the plan or program has been communicated in writing to the laborers or mechanics affected, and records which show the costs anticipated or the actual cost incurred in providing such benefits. Contractors employing apprentices or trainees under approved programs shall maintain written evidence of the registration of apprenticeship programs and certification of trainee programs, the registration of the apprentices and trainees, and the ratios and wage rates prescribed in the applicable programs.

(ii)(a) The Contractor shall submit weekly for each week in which any contract work is performed a copy of all payrolls to HUD or its designee if the agency is a party to the Contract, but if the agency is not such a party, the Contractor shall submit the payrolls to the applicant, sponsor, or Owner, as the case may be, for transmission to HUD or its designee. The payrolls submitted shall set out accurately and completely all of the information required to be maintained under 29 CFR 5.5(a)(3)(i), except that full social security numbers and home addresses shall not be included on weekly transmittals. Instead the payrolls shall only need to include an individually identifying number for each employee (e.g., the last four digits of the employee's social security number). The required weekly payroll information may be submitted in any form desired, whether paper (Optional Form WH-347 is available for this purpose from the Wage and Hour Division Web site at <http://www.dol.gov/whd/forms/wh347.pdf> or its successor site), or electronically pursuant to Program Obligations. The prime contractor is responsible for the submission of copies of payrolls by all subcontractors. Contractors and subcontractors shall maintain the full social security number and current address of each covered worker, and shall provide them upon request to HUD or its designee if the agency is a party to the Contract, but if the agency is not such a party, the Contractor will submit the payrolls to the applicant sponsor, or Owner, as the case may be, for transmission to HUD or its designee, the Contractor, or the Wage and Hour Division of the Department of Labor for purposes of an investigation or audit of compliance with prevailing wage requirements. It is not a violation of this subparagraph for a prime contractor to require a subcontractor to provide addresses and social security numbers to the prime contractor for its own records, without weekly submission to HUD or its designee.

(b) Each payroll submitted shall be accompanied by a "Statement of Compliance," signed by the Contractor or subcontractor or his or her agent who pays or

supervises the payment of the persons employed under the Contract and shall certify the following:

(1) That the payroll for the payroll period contains the information required to be provided under 29 CFR 5.5(a)(3)(ii), the appropriate information is being maintained under 29 CFR 5.5(a)(3)(i), and that such information is correct and complete.

(2) That each laborer or mechanic (including each helper, apprentice, and trainee) employed on the Contract during the payroll period has been paid the full weekly wages earned, without rebate, either directly or indirectly, and that no deductions have been made either directly or indirectly from the full wages earned, other than permissible deductions as set forth in 29 CFR Part 3;

(3) That each laborer or mechanic has been paid not less than the applicable wage rates and fringe benefits or cash equivalents for the classification of work performed, as specified in the applicable wage determination incorporated into the Contract.

(c) The weekly submission of a properly executed certification set forth on the reverse side of Optional Form WH-347 shall satisfy the requirement for submission of the "Statement of Compliance" required by subparagraph B.3.(ii)(b) of this Article.

(d) The falsification of any of the above certifications may subject the Contractor or subcontractor to civil or criminal prosecution under Section 1001 of Title 18 and Sections 3801 et seq of Title 31 of the United States Code.

(iii) The Contractor or subcontractor shall make the records required under subparagraph B.3.(i) of this Article available for inspection, copying, or transcription by authorized representatives of HUD or its designee or the Department of Labor, and shall permit such representatives to interview employees during working hours on the job. If the Contractor or subcontractor fails to submit the required records or to make them available, HUD or its designee may, after written notice to the Contractor, sponsor, applicant, or Owner, take such action as may be necessary to cause the suspension of any further payment, advance, or guarantee of funds. Furthermore, failure to submit the required records upon request or to make such records available may be grounds for debarment action pursuant to 29 CFR 5.12.

4. Apprentices and Trainees.

(i) **Apprentices.** Apprentices shall be permitted to work at less than the predetermined rate for the work they performed when they are employed pursuant to and individually registered in a bona fide apprenticeship program registered with the U.S. Department of Labor, Employment and Training Administration, Office of Apprenticeship, or with a State Apprenticeship Agency recognized by such Office, or if a person is employed in his or her first ninety (90) days of probationary employment as an apprentice in such an apprenticeship program, who is not individually registered in the

program, but who has been certified by the Office of Apprenticeship, or a State Apprenticeship Agency (where appropriate) to be eligible for probationary employment as an apprentice. The allowable ratio of apprentices to journeymen on the job site in any craft classification shall not be greater than the ratio permitted to the Contractor as to the entire work force under the registered program. Any worker listed on a payroll at an apprentice wage rate, who is not registered or otherwise employed as stated above, shall be paid not less than the applicable wage rate on the wage determination for the classification of work actually performed. In addition, any apprentice performing work on the job site in excess of the ratio permitted under the registered program shall be paid not less than the applicable wage rate on the wage determination for the work actually performed. Where the Contractor is performing construction on a project in a locality other than that in which its program is registered, the ratios and wage rates (expressed in percentages of the journeyman's hourly rate) specified in the Contractor's or subcontractor's registered program shall be observed. Every apprentice must be paid at not less than the rate specified in the registered program for the apprentice's level of progress, expressed as a percentage of the journeymen hourly rate specified in the applicable wage determination. Apprentices shall be paid fringe benefits in accordance with the provisions of the apprenticeship program. If the apprenticeship program does not specify fringe benefits, apprentices must be paid the full amount of fringe benefits listed on the wage determination for the applicable classification. If the Administrator determines that a different practice prevails for the applicable apprentice classification, fringes shall be paid in accordance with that determination. In the event the Office of Apprenticeship, or a State Apprenticeship Agency recognized by such Office, withdraws approval of an apprenticeship program, the Contractor shall no longer be permitted to utilize apprentices at less than the applicable predetermined rate for the work performed until an acceptable program is approved.

(ii) **Trainees.** Except as provided in 29 CFR 5.16, trainees shall not be permitted to work at less than the predetermined rate for the work performed unless they are employed pursuant to and individually registered in a program which has received prior approval, evidenced by formal certification by the U.S. Department of Labor, Employment and Training Administration. The ratio of trainees to journeymen on the job site shall not be greater than permitted under the plan approved by the Employment and Training Administration. Every trainee must be paid at not less than the rate specified in the approved program for the trainee's level of progress, expressed as a percentage of the journeyman's hourly rate specified in the applicable wage determination. Trainees shall be paid fringe benefits in accordance with the provisions of the trainee program. If the trainee program does not mention fringe benefits, trainees shall be paid the full amount of fringe benefits listed on the wage determination unless the Administrator of the Wage and Hour Division determines that there is an apprenticeship program associated with the corresponding journeyman wage rate on the wage determination which provides for less than full fringe benefits for apprentices. Any employee listed on the payroll at a trainee rate who is not registered and participating in a training plan approved by the Employment and Training Administration shall be paid not less than the applicable wage rate on the wage determination for the classification of work actually performed. In addition, any trainee performing work on

the job site in excess of the ratio permitted under the registered program shall be paid not less than the applicable wage rate on the wage determination for the work actually performed. In the event the Employment and Training Administration withdraws approval of a training program, the Contractor shall no longer be permitted to utilize trainees at less than the applicable predetermined rate for the work performed until an acceptable program is approved.

(iii) **Equal employment opportunity.** The utilization of apprentices, trainees and journeymen under 29 CFR Part 5 shall be in conformity with the equal employment opportunity requirements of Executive Order 11246, as amended, and 29 CFR Part 30.

5. Compliance with Copeland Act Requirements. The Contractor shall comply with the requirements of 29 CFR Part 3, which are incorporated by reference in this Contract.

6. Subcontracts. The Contractor or subcontractor shall insert in any subcontracts the clauses set forth in subparagraphs 1 through 10 of this paragraph B and such other clauses as HUD or its designee may by appropriate instructions require, and a copy of the applicable prevailing wage determination, and also a clause requiring the subcontractors to include these clauses in any lower tier subcontracts. The prime contractor shall be responsible for the compliance by any subcontractor or lower tier subcontractor with all Contract clauses referenced in this subparagraph.

7. Contract termination and debarment. A breach of the Contract clauses in 29 CFR 5.5 may be grounds for termination of the Contract, and for debarment as a contractor or a subcontractor as provided in 29 CFR 5.12.

8. Compliance with Davis-Bacon and Related Act Requirements. All rulings and interpretations of the Davis-Bacon and Related Acts contained in 29 CFR Parts 1, 3, and 5 are herein incorporated by reference in this Contract.

9. Disputes concerning labor standards. Disputes arising out of the labor standards provisions of this Contract shall not be subject to the general disputes clause of this Contract. Such disputes shall be resolved in accordance with the procedures of the Department of Labor set forth in 29 CFR Parts 5, 6, and 7. Disputes within the meaning of this clause include disputes between the Contractor (or any of its subcontractors) and HUD or its designee, the U.S. Department of Labor, or the employees or their representatives.

10. Certification of Eligibility.

(i) By entering into this Contract, the Contractor certifies that neither it (nor he or she) nor any person or firm who has an interest in the Contractor's firm is a person or firm ineligible to be awarded Government contracts by virtue of Section 3(a) of the Davis-Bacon Act (40 U.S.C. 3144(b)(2)) or 29 CFR 5.12(a)(1) or to be awarded HUD contracts or participate in HUD programs pursuant to 24 CFR Part 24.

(ii) No part of this Contract shall be subcontracted to any person or firm ineligible for award of a Government contract by virtue of Section 3(a) of the Davis-Bacon Act (40 U.S.C. 3144(b)(2)) or 29 CFR 5.12(a)(1) or to be awarded HUD contracts or participate in HUD programs pursuant to 24 CFR Part 24.

(iii) The penalty for making false statements is prescribed in the U.S. Criminal Code, 18 U.S.C. 1001. Additionally, U.S. Criminal Code, Section 1010, Title 18, U.S.C., "Federal Housing Administration transactions", provides in part: "Whoever, for the purpose of . . . influencing in any way the action of such Department . . . makes, passes, utters or publishes any statement, knowing the same to be false . . . shall be fined under this title or imprisoned not more than two years, or both."

C. Contract Work Hours and Safety Standards Act.

1. Applicability and Definitions. This paragraph C of Article 1 is applicable only if a direct form of federal assistance is involved, such as Section 8, Section 202/811 Capital Advance, grants etc., and is applicable only where the prime contract is in an amount greater than \$100,000. As used in this paragraph C, the terms "laborers" and "mechanics" include watchmen and guards.

2. Overtime requirements. No contractor or subcontractor contracting for any part of the Contract work that may require or involve the employment of laborers or mechanics shall require or permit any such laborer or mechanic in any workweek in which he or she is employed on such work to work in excess of forty (40) hours in such workweek unless such laborer or mechanic receives compensation at a rate not less than one and one-half times the basic rate of pay for all hours worked in excess of forty (40) hours in such workweek.

3. Violation; liability for unpaid wages; liquidated damages. In the event of any violation of the immediately preceding subparagraph C.2, the Contractor and any subcontractor responsible therefore shall be liable for the unpaid wages. In addition, the Contractor and subcontractor shall be liable to the United States (in the case of work done under contract for the District of Columbia or a territory, to such District or to such territory) for liquidated damages. Such liquidated damages shall be computed with respect to each individual laborer or mechanic, including watchmen and guards, employed in violation of such subparagraph, in the sum of \$10 for each calendar day on which such individual was required or permitted to work in excess of the standard workweek of forty (40) hours without payment of the overtime wages required by the clause set forth in such subparagraph.

4. Withholding for unpaid wages and liquidated damages. HUD or its designee shall, upon its own action or upon written request of an authorized representative of the Department of Labor, withhold or cause to be withheld from any moneys payable on account of work performed by the Contractor or subcontractor under any such contract, or under any other Federal contract with the same prime contractor, or under any other Federally-assisted contract subject to the Contract Work

Hours and Safety Standards Act which is held by the same prime contractor such sums as may be determined to be necessary to satisfy any liabilities of such Contractor or subcontractor for unpaid wages and liquidated damages as provided in the clause set forth in subparagraph 3 of this paragraph C.

5. Subcontracts. The Contractor or subcontractor shall insert in any subcontracts the clauses set forth in subparagraphs 1 through 5 of this paragraph C and also a clause requiring the subcontractors to include these clauses in any lower tier subcontracts. The prime contractor shall be responsible for compliance by any subcontractor or lower tier subcontractor with the clauses set forth in such subparagraphs 1 through 5.

D. Certification.

For projects with Security Instruments insured under the National Housing Act, as amended, that are subject to paragraph B of this Article 1, the Contractor is required to execute the Contractor's Prevailing Wage Certificate within HUD-92448 as a condition precedent to insurance by HUD of the Loan, or an advance thereof, made or to be made by the Lender in connection with the construction of the Project.

Article 2: Equal Employment Opportunity

A. Applicability. This Article 2 applies to any contract for construction work, or modification thereof, as defined in the regulations of the Secretary of Labor at 41 CFR Chapter 60, which is paid for in whole or in part with funds obtained from the Federal Government or borrowed on the credit of the Federal Government pursuant to a grant, contract, loan insurance, or guarantee, or undertaken pursuant to any Federal program involving such grant, contract, loan, insurance, or guarantee.

B. The Contractor shall not discriminate against any employee or applicant for employment because of race, color, religion, sex, sexual orientation, gender identity, disability, or national origin. The Contractor shall take affirmative action to ensure that applicants are employed, and that employees are treated during employment without regard to their race, color, religion, sex, sexual orientation, gender identity, disability or national origin. Such action shall include, but not be limited to the following: employment, upgrading, demotion, or transfer; recruitment or recruitment advertising; layoff or termination; rates of pay or other forms of compensation; and selection for training including apprenticeship. The Contractor agrees to post in conspicuous places available to employees and applicants for employment notices to be provided setting forth the provisions of this nondiscrimination clause.

C. The Contractor shall, in all solicitations or advertisements for employees placed by or on behalf of the Contractor state that all qualified applicants shall receive consideration for employment without regard to race, color, religion, sex, sexual orientation, gender identity, disability, or national origin.

D. The Contractor shall send to each labor union or representative of workers with which it has a collective bargaining agreement or other contract or understanding a

notice to be provided advising the said labor union or workers representatives of the Contractor's commitments hereunder, and shall post copies of the notice in conspicuous places available to employees and applicants for employment.

E. The Contractor shall comply with all provisions of Executive Order 11246 of September 24, 1965 and of the rules, regulations, and relevant orders of the Secretary of Labor.

F. The Contractor shall furnish all information and reports required by Executive Order 11246 of September 24, 1965, and by rules, regulations, and orders of the Secretary of Labor, or pursuant thereto, and shall permit access to its books, records, and accounts by the Secretary of Labor for purposes of investigation to ascertain compliance with such rules, regulations, and orders.

G. In the event of the Contractor's noncompliance with the nondiscrimination clauses of this Contract or with any of the said rules, regulations, or orders, this Contract may be canceled, terminated, or suspended in whole or in part and Contractor may be declared ineligible for further government contracts or federally assisted construction contracts in accordance with procedures authorized in Executive Order 11246 of September 24, 1965, and such other sanctions may be imposed and remedies invoked as provided in Executive Order 11246 of September 24, 1965, or by rule, regulations or order of the Secretary of Labor, or as otherwise provided by law.

H. The Contractor shall include the provisions of paragraphs A through H of this Article 2 in every subcontract or purchase order unless exempted by rules, regulations, or orders of the Secretary of Labor issued pursuant to Section 204 of Executive Order 11246 of September 24, 1965, so that such provisions shall be binding upon each subcontractor or vendor. The Contractor shall take such action with respect to any subcontract or purchase order as HUD or the Secretary of Labor may direct as a means of enforcing such provisions, including sanctions for noncompliance. *Provided, however,* that in the event the Contractor becomes involved in, or is threatened with, litigation with a subcontractor or vendor as a result of such direction by HUD or the Secretary of Labor, the Contractor may request the United States to enter into such litigation to protect the interests of the United States.

Article 3: Equal Opportunity for Businesses and Lower Income Persons Located Within the Project Area

A. This Article 3 is applicable to projects covered by Section 3, as defined in 24 CFR Part 135.

B. The work to be performed under this Contract is on a project assisted under a program providing Federal financial assistance from HUD and is subject to the requirements of Section 3 of the Housing and Urban Development Act of 1968, as amended, 12 U.S.C. 1701u. Section 3 requires that to the greatest extent feasible opportunities for training and employment be given to low and very-low income residents of the unit of local government or the metropolitan area (or non-metropolitan county) as determined by HUD in which the Project is located and contracts for work in connection with the Project be awarded to business concerns which are located in, or owned in substantial part by persons residing in the same metropolitan area (or non-metropolitan county) as the Project.

Article 4: Health and Safety

A. This Article 4 is applicable only where the prime contract is in an amount greater than \$100,000.

B. No laborer or mechanic shall be required to work in surroundings or under working conditions which are unsanitary, hazardous, or dangerous to his or her health and safety as determined under construction safety and health standards promulgated by the Secretary of Labor by regulation.

C. The Contractor shall comply with all regulations issued by the Secretary of Labor pursuant to 29 CFR Part 1926, and failure to comply may result in imposition of sanctions pursuant to the Contract Work Hours and Safety Standards Act, 40 USC 3701 et seq.

D. The Contractor shall include the provisions of this Article 4 in every subcontract so that such provisions shall be binding on each subcontractor. The Contractor shall take such action with respect to any subcontract as HUD or the Secretary of Labor shall direct as a means of enforcing such provisions.

The HUD Multifamily Accelerated Processing (MAP) Guide (MAP 5.4.B.1.b) requires the design architect to produce drawings and specifications that comply with HUD standards and criteria.

The following HUD Special Conditions add to or modify the AIA A201-2007, *General Conditions of the Contract for Construction*. They must be included in the “Boiler Plate” of the Project Manual/Specification, without the footnote references, which are indicated like this: ~~(Footnote.)~~

“HUD SPECIAL CONDITIONS”
NOTES FOR MULTIFAMILY INSURED PROGRAMS
(Revised May 2011)

1. Article 2, 2.2.5, state the number of sets of plans and specs to be provided to the contractor at no cost (Typically 20 sets for a 20 to 40 unit project). ~~(NOTE-Also add to AIA B108, Article 12 as Basic Services, the number of sets to be provided at no cost.)~~
- ~~2. Article 3, 3.7.1, permits, fees, and testing shall be paid by contractor. Soils testing during construction shall be provided and paid by contractor. (See footnote a.)~~
3. Article 3, 3.10.1, contractor shall prepare and submit form HUD-5372, *Construction Progress Schedule* (prepared according to instructions on reverse of form) to HUD for acceptance a minimum of 30 days prior to HUD's Pre-Construction Conference. ~~(See footnote b.)~~
4. Article 3, 3.11.1, the contractor will be provided with a set of plans and specifications marked "HUD As-Built Set" at the HUD Pre-Construction Conference. The set marked "HUD As-Built Set" shall be maintained and used by the contractor to record all construction changes, modifications, materials, selections, etc. Upon completion of the project construction and prior to release of 10% retainage, the contractor shall return the "HUD As-Built Set" of plans and specs to the HUD Representative as part of "final completion" requirements. The "HUD As-Built Set" is in addition to any other as-built or record documents required by the owner, architect, or others. ~~(See footnotes c & t.)~~
5. Article 3, 3.11.1, the contractor is required to provide a topographic land survey map and form HUD-91073M, *Surveyor's Report*, completed by a licensed land surveyor as part of final completion and project close-out. ~~The survey map and Report shall be completed in accordance with the instructions on form HUD-92457, MAP Appendix 5I.C, and construction~~

~~contract(s) form HUD-92442M, Article 5.C. The contractor shall provide progress survey maps from time to time which show the project to be entirely within the property and will not encroach upon any easement or right-of-way, or the land of others and is wholly within building restriction lines (set-backs) as part of applications for payment. The contractor shall provide updated final property survey maps and Reports for HUD's final endorsement (minimum 5 copies) dated less than 90 days for the Map and 30 days for the Report of final endorsement. Survey maps and Reports shall be acceptable to HUD. (See footnotes d & t.)~~

6. Article 3, 3.16.1, the contractor shall provide HUD with access to the work. (See footnote e.)
7. Article 4, 4.2.5, requests for payment shall be prepared and submitted using form HUD-92448, *Contractor's Requisition - Project Mortgages*. (See footnote g.)
8. Article 4, 4.2.8, on-site change orders shall be prepared utilizing form HUD-92437, *Request for Construction Changes on Project Mortgages*. Off-site changes shall be requested by letter or other form acceptable to HUD, but not form HUD-92437. Requests for payment of change orders shall be submitted utilizing form HUD-92464, *Request for Approval of Advance of Escrow Funds*. (See footnote h.)
9. Article 4, 4.2.9., the date of final completion shall be the date the HUD Representative signs the final HUD Representative's form HUD-5379, *Trip Report*, provided that the Report is subsequently endorsed by HUD. Final completion includes all contract requirements including but not limited to: completion of all punch list items, executed form FHA 2485, *Permission to Occupy - Property Mortgages*, As-Built Survey and Surveyor's Report, As-Built Plans and Specifications, warranties, and change orders. (See footnotes i & t.)
10. Article 5, 5.2.1, also submit copies to HUD. (See footnote j.)
11. Article 7, 7.1.1, proposed changes shall be first discussed among the architect, contractor, owner, and HUD Representative. The HUD Representative makes a preliminary determination of technical acceptability prior to approval by owner and HUD. Changes may be effected only with the prior written approval of HUD under such conditions as HUD may establish. (See footnote k.)
12. Article 7, 7.3.1, all change orders must be analyzed and the findings reviewed and accepted by HUD prior to the requested construction change being adopted, included or incorporated into the construction,

- including architects' field orders. HUD has the right to interpret the contract documents and determine compliance therewith. [\(See footnote l.\)](#)
13. Article 7, 7.4.1, minor changes in work will be issued in the form prescribed by HUD after analysis and review. [\(See footnotes h, k, and l.\)](#)
 14. Article 8, 8.1.2, the contractor shall provide written notification to HUD stating the actual date of construction start. [\(See footnote m.\)](#)
 15. Article 8, 8.3.1, any contract time extension must be analyzed and the findings reviewed and accepted by HUD, see 8 (4.2.8.), 11 (7.1.1), 12 (7.3.1) and 26 (15.1.5) above. [\(See footnotes h, k, and l.\)](#)
 16. Article 9, 9.2.1, the schedule of values shall be prepared on form HUD-2328, *Contractor's and/or Mortgagor's Cost Breakdown - Schedule of Values*. [\(See footnote n.\)](#)
 17. Article 9, 9.3.1, applications for payment shall be prepared on form HUD-92448, *Contractor's Requisition - Project Mortgages*. [\(See footnote o.\)](#)
 18. Article 9, 9.3.1.1, applications for Payment of changes shall be submitted on form HUD-92464, see 8 (4.2.8) above. [\(See footnote h.\)](#)
 19. Article 9, 9.3.2, payment for materials and equipment stored off-site shall be made in compliance with applicable HUD requirements. [\(See footnote p.\)](#)
 20. Article 9, 9.4.1, certificates for payment shall be as prescribed by HUD, utilizing HUD forms. Form HUD-92448, shall be prepared by the contractor and signed by the contractor, architect and HUD Representative. The HUD-92448 shall be submitted to HUD in quadruplicate by the owner/sponsor as prescribed by HUD. All requests for payment must be analyzed and the findings reviewed and accepted by HUD prior to payment, see 7 (4.2.5) above. [\(See footnote q.\)](#)
 21. Article 9, 9.5.1, payment will be withheld for any change from the contract documents which has not been accepted by HUD, see 8 (4.2.8), 11 (7.1.1), 12 (7.3.1) and 13 (7.4.1) above. An additional amount will be withheld to cover the cost of any repair or replacement necessary to bring the work into compliance with the contract documents. [\(See footnotes h, k, l.\)](#)
 22. Article 9, 9.7.1, requests for payment shall be acceptable to HUD prior to owner's payment to the contractor, see 7 (4.2.5), 17 (9.3.1) and 20 (9.4.1) above.

23. Article 9, 9.8.1, form FHA-2485, *Permission to Occupy - Project Mortgages*, shall be prepared (original and four copies) and submitted to HUD with copies of the local authorities certificates of occupancy attached. The architect and HUD Representative will make an inspection to determine whether the units listed on form FHA-2485 or portions thereof are acceptable for occupancy and the form FHA-2485 is subsequently endorsed by HUD. [\(See footnote r.\)](#)
24. Article 9, 9.8.2, upon receipt of the contractor's punchlist, the architect and HUD Representative will jointly make an inspection. The date of final completion will be established as noted in 9 (4.2.9) above.
25. Article 9, 9.10.1, final completion and final payment must be analyzed and the findings reviewed and accepted by HUD. [\(See footnote s.\)](#)
26. Article 15, 15.1.5, Claims for additional time shall be submitted as a single separate item on form HUD-92437, not included as part of or along with other types of requests, and requests for payment of changes shall be in the form required by HUD and acceptable to HUD, see 8 (4.2.8) above. [\(See footnote h.\)](#)

FOOTNOTES: These footnotes provide cross references and location of requirements for the design representative and project architect's use in preparing specs. They are not to be typed in as part of the HUD Special Conditions.

- a. Reference: Construction Contract(s), HUD-92442M (5/11) Article 7, note: the architect must write specs which include all the soils engineer's recommendations.
- b. Reference: MAP 5.7.B.
- c. Reference: MAP 5.7.E.
- d. Reference: Construction Contract(s), HUD-92442M Article 7, MAP Appendix 5E.C.
- e. Reference: Construction Contract(s), HUD-92442M Article 10.
- f. NOT USED.
- g. Reference: Construction Contract(s) HUD-92442M Article 5.A., MAP Appendix 12B.A.
- h. Reference: MAP 12.8.B, Construction Contract HUD-92442M Article 2.D.
- i. Reference: MAP 13.6.A, MAP 13.6.B, Construction Contract(s) HUD-92442M Article 3.B.
- j. Reference: HUD Amendment To AIA B108 (HUD-92408M).
- k. Reference: MAP 12.8.B, Construction Contract(s) HUD-92442M Article 2.D.
- l. Reference: MAP 12.8.B, Construction Contract(s) HUD-92442M Article 2.D. and 7. B, the HUD Amendment To AIA B108 (HUD-92408M).
- m. Reference: Construction Contract(s) HUD-92442M Article 3, MAP 12.3.D.4.
- n. Reference: MAP 12.3.C.1.d, MAP Appendix 12B.A.1.e, Construction Contract(s) HUD-92442M Article 5.A.
- o. Reference: MAP Appendix 12B.A, Construction Contract(s) HUD-92442M Article 5.A.
- p. Reference: MAP Appendix 12B.B.5, MAP Appendix 12C.

- q. MAP Appendix 12B.A, Handbook 4480.1, 2448-1 through 2448-6, Construction Contract(s) HUD-92442M Article 5.A.
- r. Reference: MAP 12.3.D.10, MAP 12.6.A, Construction Contract(s) HUD-92442M Article 7.A.
- s. Reference: Construction Contract(s) HUD-92442M Article 5,6,7,8 and 13.

"General Decision Number: WA20200094 03/06/2020

Superseded General Decision Number: WA20190094

State: Washington

Construction Type: Residential

County: Snohomish County in Washington.

RESIDENTIAL CONSTRUCTION PROJECTS (consisting of single family homes and apartments up to and including 4 stories).

Note: Under Executive Order (EO) 13658, an hourly minimum wage of \$10.80 for calendar year 2020 applies to all contracts subject to the Davis-Bacon Act for which the contract is awarded (and any solicitation was issued) on or after January 1, 2015. If this contract is covered by the EO, the contractor must pay all workers in any classification listed on this wage determination at least \$10.80 per hour (or the applicable wage rate listed on this wage determination, if it is higher) for all hours spent performing on the contract in calendar year 2020. If this contract is covered by the EO and a classification considered necessary for performance of work on the contract does not appear on this wage determination, the contractor must pay workers in that classification at least the wage rate determined through the conformance process set forth in 29 CFR 5.5(a)(1)(ii) (or the EO minimum wage rate, if it is higher than the conformed wage rate). The EO minimum wage rate will be adjusted annually. Please note that this EO applies to the above-mentioned types of contracts entered into by the federal government that are subject to the Davis-Bacon Act itself, but it does not apply to contracts subject only to the Davis-Bacon Related Acts, including those set forth at 29 CFR 5.1(a)(2)-(60). Additional information on contractor requirements and worker protections under the EO is available at www.dol.gov/whd/govcontracts.

Modification Number	Publication Date
0	01/03/2020
1	03/06/2020

BRWA0001-018 06/01/2017

	Rates	Fringes
BRICK POINTER/CAULKER/CLEANER....	\$ 39.46	16.15
BRICKLAYER.....	\$ 39.46	16.15

* ELEV0019-001 01/01/2020

Rates	Fringes
-------	---------

ELEVATOR MECHANIC.....\$ 55.86 34.765+a+b

FOOTNOTE:

- a. PAID VACATION: Employer contributes 8% of regular hourly rate as vacation pay credit for employees with more than 5 years of service, and 6% for 6 months to 5 years of service.
- b. PAID HOLIDAYS: New Years Day, Memorial Day, Independence Day, Labor Day, Veterans Day, Thanksgiving Day, Friday after Thanksgiving, and Christmas Day.

LABO0238-001 06/01/2019

Rates Fringes

LABORER (Mason Tender -
Cement/Concrete).....\$ 28.21 13.00

LABO0242-001 06/01/2019

Rates Fringes

LABORER (Mason Tender - Brick)...\$ 40.36 11.94

PAIN0188-006 07/01/2018

Rates Fringes

GLAZIER.....\$ 29.28 12.66

PLAS0528-003 06/01/2019

Rates Fringes

CEMENT MASON/CONCRETE FINISHER...\$ 44.43 18.04

SFWA0699-001 09/01/2017

Rates Fringes

SPRINKLER FITTER.....\$ 34.41 16.07

SHEE0066-044 06/01/2019

Rates Fringes

SHEET METAL WORKER (Including
HVAC Duct Installation).....\$ 56.09 28.02

TEAM0690-010 01/01/2019

Rates Fringes

TRUCK DRIVER

GROUP 3.....	\$ 28.16	17.40
GROUP 4.....	\$ 28.49	17.40
GROUP 5.....	\$ 28.60	17.40
GROUP 6.....	\$ 28.76	17.40
GROUP 7.....	\$ 29.30	17.40
GROUP 8.....	\$ 29.62	17.40

TRUCK DRIVERS CLASSIFICATIONS

GROUP 3: Trucks, side, end, bottom and articulated end dump (3 yards to and including 6 yds.)

GROUP 4: Trucks, side, end, bottom and articulated end dump (over 6 yds. to & including 12 yds.)

GROUP 5: Trucks, side, end, bottom and articulated end dump (over 12 yds. to & including 20 yds.)

GROUP 6: Trucks, side, end, bottom and articulated end dump (over 20 yds. to & including 40 yds.)

GROUP 7: Truck, side, end, bottom and articulated end dump (over 40 yds. to & including 100 yds.)

GROUP 8: Trucks, side, end, bottom and articulated end dump (over 100 yds.)

FOOTNOTE A - Anyone working on a HAZMAT job, where HAZMAT certification is required, shall be compensated as a premium, in addition to the classification working in as follows:

LEVEL C-D: - \$.50 PER HOUR - This level may use an air purifying respirator or additional protective clothing.

LEVEL A-B: - \$1.00 PER HOUR - Uses supplied air in conjunction with a chemical splash suit or fully encapsulated suit with a self-contained breathing apparatus.

Employees shall be paid Hazmat pay in increments of four(4) and eight(8) hours.

SUWA2011-014 06/27/2014

	Rates	Fringes
CARPENTER.....	\$ 24.45	4.71
DRYWALL HANGER AND METAL STUD INSTALLER.....	\$ 24.59	0.00
ELECTRICIAN.....	\$ 33.54	11.71
LABORER: Common or General.....	\$ 19.07	3.27
OPERATOR: Backhoe/Excavator/Trackhoe.....	\$ 32.74	15.15

OPERATOR: Bobcat/Skid Steer/Skid Loader.....	\$ 17.53	0.00
OPERATOR: Bulldozer.....	\$ 29.63	0.00
OPERATOR: Concrete Pump.....	\$ 33.57	15.15
PAINTER (Brush, Roller, and Spray).....	\$ 23.24	7.20
PAINTER: Drywall Finishing/Taping Only.....	\$ 34.36	14.34
PLUMBER.....	\$ 30.53	7.84
ROOFER.....	\$ 23.12	2.90

WELDERS - Receive rate prescribed for craft performing operation to which welding is incidental.

=====

Note: Executive Order (EO) 13706, Establishing Paid Sick Leave for Federal Contractors applies to all contracts subject to the Davis-Bacon Act for which the contract is awarded (and any solicitation was issued) on or after January 1, 2017. If this contract is covered by the EO, the contractor must provide employees with 1 hour of paid sick leave for every 30 hours they work, up to 56 hours of paid sick leave each year. Employees must be permitted to use paid sick leave for their own illness, injury or other health-related needs, including preventive care; to assist a family member (or person who is like family to the employee) who is ill, injured, or has other health-related needs, including preventive care; or for reasons resulting from, or to assist a family member (or person who is like family to the employee) who is a victim of, domestic violence, sexual assault, or stalking. Additional information on contractor requirements and worker protections under the EO is available at www.dol.gov/whd/govcontracts.

Unlisted classifications needed for work not included within the scope of the classifications listed may be added after award only as provided in the labor standards contract clauses (29CFR 5.5 (a) (1) (ii)).

The body of each wage determination lists the classification and wage rates that have been found to be prevailing for the cited type(s) of construction in the area covered by the wage determination. The classifications are listed in alphabetical

order of ""identifiers"" that indicate whether the particular rate is a union rate (current union negotiated rate for local), a survey rate (weighted average rate) or a union average rate (weighted union average rate).

Union Rate Identifiers

A four letter classification abbreviation identifier enclosed in dotted lines beginning with characters other than ""SU"" or ""UAVG"" denotes that the union classification and rate were prevailing for that classification in the survey. Example: PLUM0198-005 07/01/2014. PLUM is an abbreviation identifier of the union which prevailed in the survey for this classification, which in this example would be Plumbers. 0198 indicates the local union number or district council number where applicable, i.e., Plumbers Local 0198. The next number, 005 in the example, is an internal number used in processing the wage determination. 07/01/2014 is the effective date of the most current negotiated rate, which in this example is July 1, 2014.

Union prevailing wage rates are updated to reflect all rate changes in the collective bargaining agreement (CBA) governing this classification and rate.

Survey Rate Identifiers

Classifications listed under the ""SU"" identifier indicate that no one rate prevailed for this classification in the survey and the published rate is derived by computing a weighted average rate based on all the rates reported in the survey for that classification. As this weighted average rate includes all rates reported in the survey, it may include both union and non-union rates. Example: SULA2012-007 5/13/2014. SU indicates the rates are survey rates based on a weighted average calculation of rates and are not majority rates. LA indicates the State of Louisiana. 2012 is the year of survey on which these classifications and rates are based. The next number, 007 in the example, is an internal number used in producing the wage determination. 5/13/2014 indicates the survey completion date for the classifications and rates under that identifier.

Survey wage rates are not updated and remain in effect until a new survey is conducted.

Union Average Rate Identifiers

Classification(s) listed under the UAVG identifier indicate that no single majority rate prevailed for those classifications; however, 100% of the data reported for the classifications was union data. EXAMPLE: UAVG-OH-0010 08/29/2014. UAVG indicates that the rate is a weighted union average rate. OH indicates the state. The next number, 0010 in the example, is an internal number used in producing the wage

determination. 08/29/2014 indicates the survey completion date for the classifications and rates under that identifier.

A UAVG rate will be updated once a year, usually in January of each year, to reflect a weighted average of the current negotiated/CBA rate of the union locals from which the rate is based.

WAGE DETERMINATION APPEALS PROCESS

1.) Has there been an initial decision in the matter? This can be:

- * an existing published wage determination
- * a survey underlying a wage determination
- * a Wage and Hour Division letter setting forth a position on a wage determination matter
- * a conformance (additional classification and rate) ruling

On survey related matters, initial contact, including requests for summaries of surveys, should be with the Wage and Hour Regional Office for the area in which the survey was conducted because those Regional Offices have responsibility for the Davis-Bacon survey program. If the response from this initial contact is not satisfactory, then the process described in 2.) and 3.) should be followed.

With regard to any other matter not yet ripe for the formal process described here, initial contact should be with the Branch of Construction Wage Determinations. Write to:

Branch of Construction Wage Determinations
Wage and Hour Division
U.S. Department of Labor
200 Constitution Avenue, N.W.
Washington, DC 20210

2.) If the answer to the question in 1.) is yes, then an interested party (those affected by the action) can request review and reconsideration from the Wage and Hour Administrator (See 29 CFR Part 1.8 and 29 CFR Part 7). Write to:

Wage and Hour Administrator
U.S. Department of Labor
200 Constitution Avenue, N.W.
Washington, DC 20210

The request should be accompanied by a full statement of the interested party's position and by any information (wage payment data, project description, area practice material,

etc.) that the requestor considers relevant to the issue.

3.) If the decision of the Administrator is not favorable, an interested party may appeal directly to the Administrative Review Board (formerly the Wage Appeals Board). Write to:

Administrative Review Board
U.S. Department of Labor
200 Constitution Avenue, N.W.
Washington, DC 20210

4.) All decisions by the Administrative Review Board are final.

=====

END OF GENERAL DECISION"

CONSTRUCTION CONTRACT

**U.S. Department of Housing and
Urban Development**
Office of Housing

OMB Approval No. 2502-0598
(Exp. 9/30/2021)

Public Reporting Burden for this collection of information is estimated to average 1 hour per response, including the time for reviewing instructions, searching existing data sources, gathering and maintaining the data needed, and completing and reviewing the collection of information. Response to this request for information is required in order to receive the benefits to be derived. This agency may not collect this information, and you are not required to complete this form unless it displays a currently valid OMB control number. While no assurance of confidentiality is pledged to respondents, HUD generally discloses this data only in response to a Freedom of Information Act request.

Warning: Federal law provides that anyone who knowingly or willfully submits (or causes to submit) a document containing any false, fictitious, misleading, or fraudulent statement/certification or entry may be criminally prosecuted and may incur civil administrative liability. Penalties upon conviction can include a fine and imprisonment, as provided pursuant to applicable law, which includes, but is not limited to, 18 U.S.C. 1001, 1010, 1012; 31 U.S.C. 3729, 3802, 24 C.F.R. Parts 25, 28 and 30, and 2 C.F.R. Parts 180 and 2424.

HUD Project No.: _____
Project Name: _____

Cost Plus Contract _____
Lump Sum Contract _____

THIS CONSTRUCTION CONTRACT (“Contract”) is made this _____ day of _____, 20____, between _____ (“**Contractor**”) and _____ (“**Owner**”) (“**Parties**”).

The definition of any capitalized term or word used herein can be found in this Contract and the General Conditions, except the term “**Project**” shall have the same definition as in the Regulatory Agreement between Borrower (Owner) and HUD, except that the term “**Program Obligations**” means (1) all applicable statutes and any regulations issued by the Secretary pursuant thereto that apply to the Project, including all amendments to such statutes and regulations, as they become effective, except that changes subject to notice and comment rulemaking shall become effective only upon completion of the rulemaking process, and (2) all current requirements in HUD handbooks and guides, notices, and mortgagee letters that apply to the Project, and all future updates, changes and amendments thereto, as they become effective, except that changes subject to notice and comment rulemaking shall become effective only upon completion of the rulemaking process, and provided that such future updates, changes and amendments shall be applicable to the Project only to the extent that they interpret, clarify and implement terms in this Contract rather than add or delete provisions from such document. Handbooks, guides, notices, and mortgagee letters are available on “HUDCLIPS,” at www.hud.gov. Any HUD form referenced herein shall be the current version of that form, and shall include any successor form adopted by HUD.

The Contractor and the Owner agree as follows:

Article 1: Scope of Contract

A. The Contract between the Parties is set forth in the “**Contract Documents**,” which consist of this Contract and the other documents identified in Article 2 below. Together, these form the entire Contract between Owner and Contractor, and by this reference these Contract Documents are fully incorporated herein. Any previously

existing contract or understanding concerning the Work contemplated by the Contract Documents is hereby revoked. Any side agreements between Owner and Contractor shall be disclosed to HUD.

B. Except to the extent specifically indicated in the Contract Documents to be the responsibility of others, Contractor shall furnish all of the materials and perform all of the Work shown on, and in accordance with, the Drawings and Specifications.

C. The Contract shall not be amended without the prior written approval of Lender and HUD in accordance with Program Obligations. Failure to receive such prior HUD and Lender approval shall render any such amendment void.

Article 2: Identification of Contract Documents

A. The Contract Documents are identified as follows:

(1) This Construction Contract (HUD-92442M) (“Contract”).

(2) The General Conditions of the Contract for Construction, AIA Document A201 – _____ {Insert year of current edition} (“General Conditions”, attached hereto as Exhibit __), expressly excepting those provisions mandating binding arbitration. If any of the provisions of this Contract conflict with the terms contained in the General Conditions, the provisions in this Contract shall control.

(3) The Supplementary Conditions to the Construction Contract (HUD-92554M), attached hereto as Exhibit __.

(4) The Drawings, an index of which is attached hereto as Exhibit__.

Number_____Title_____Pages_____

(5) The Specifications, an index of which is attached hereto as Exhibit__

Number_____Title_____Pages_____

(6) The Contractor's and/or Mortgagor's Cost Breakdown (HUD-2328), approved by HUD on the date of _____, 20____, attached hereto as Exhibit__.

(7) **[Applicable for Cost Plus Contracts when an Incentive Payment Addendum is agreed to by the Parties]** If this is designated a Cost Plus Contract, the Construction Contract Incentive Payment (HUD-

92443) form is attached hereto as Exhibit___ (Incentive Payment Addendum).

OR

[Applicable for Lump Sum Contracts when an Incentive Payment Addendum is agreed to by the Parties] If this is designated a Lump Sum Contract and there is no Identity of Interest between Contractor and Owner, the Construction Contract Incentive Payment (HUD-92443) form is attached hereto as Exhibit___ (Incentive Payment Addendum).

(8) The Prevailing Wage Determination _____ Modification Number_____, last published/modified on (date) _____, 20____, and attached hereto as Exhibit_____.

(9) Completed and fully-executed document identifying Identities of Interest among Owner, Contractor, Subcontractors, and Architect (see Appendix 8 of Handbook 4430.1 and the MAP Guide Appendices), attached hereto as Exhibit _____.

(10) Any change orders approved by HUD after the execution of this Contract.

(11) If applicable, the Retainage Reduction Rider attached hereto as Exhibit_____.

B. The Drawings and Specifications were prepared by _____ (“**Design Architect**”). The architect administering the Construction Contract is _____ (“**Architect**”).

C. A master set of the Drawings and Specifications, identified by the signatures of Owner, Contractor, Design Architect, Architect, Lender , and Contractor’s surety or guarantor (if applicable), have been placed on file with HUD, and shall govern in all matters that arise with respect to the Contract Documents.

D. Changes in the Drawings and Specifications, or any terms of the Contract Documents, including orders for extra work, changes by altering or adding to the Work, orders that shall change the design concept, or orders extending the Project Substantial Completion Deadline (identified in Article 3) may be effected only with the prior written approval of Owner’s Lender (as defined in Article 11) and HUD, and under such conditions as either Lender or HUD may establish.

Article 3: Time

A. Contractor shall commence the Work to be performed under this Contract within fourteen (14) days of this Contract and shall bring the Work to Project Substantial Completion by _____, 20____ [this date shall be dependent on when the Work

is commenced] (“**Project Substantial Completion Deadline**”).

B. “**Project Substantial Completion**” shall be the date that the HUD Representative signs the final FHA Inspection Report contained in form HUD-92485 (Permission to Occupy Project Mortgages) for the Project required by the Contract Documents and Program Obligations, provided the Permission to Occupy in the same HUD-92485 is subsequently signed by the Authorized Agent of FHA. For purposes of determining any Liquidated Damages in Article 3.E below, “**Substantial Completion**” shall be the stage in the progress of the Work when a designated portion of the Work is sufficiently complete in accordance with the Contract Documents and Program Obligations so that the Owner can occupy or utilize that designated portion of the Work for its intended use, the HUD Representative signs the FHA Inspection Report in form HUD-92485, and the Permission to Occupy in the same HUD-92485 is subsequently signed by the Authorized Agent of FHA. Notwithstanding any other provision in the Contract Documents, Contractor remains liable to complete items of incomplete construction as approved in HUD’s sole discretion.

C. The Project Substantial Completion Deadline may be extended in accordance with the terms of the General Conditions only with the prior written approval of HUD through a HUD-approved change order.

D. Contractor shall correct any defects due to faulty materials or workmanship which appear within twelve (12) months from Project Substantial Completion. Warranty for Work first performed after Project Substantial Completion or portions of the Work not specifically included in a Certificate of Substantial Completion (defined as any executed Permission to Occupy in HUD-92485) shall extend twelve (12) months from the Date of Final Completion. The “**Date of Final Completion**” shall be the date the HUD representative signs the final HUD Representative’s Trip Report (form HUD-95379) provided that the trip report is subsequently endorsed by the Construction Manager. Warranty for all Work performed after the Date of Final Completion shall extend twelve (12) months from the date all such Work is completed.

E. If Contractor does not meet the Project Substantial Completion Deadline or such date to which the Project Substantial Completion Deadline may be mutually extended by approved change order, in accordance with the Drawings and Specifications, including any authorized changes, the maximum sum stated in Article 4 (either Option 1 or Option 2) below shall be reduced by \$_____ per unit for each day of delay until Project Substantial Completion (“**Liquidated Damages**”). Liquidated Damages, however, shall not be assessed against any of the Work that has reached Substantial Completion (if applicable) in accordance with Program Obligations. When Owner submits to HUD its Cost Certification, Actual Damages shall be calculated. The term “**Actual Damages**” is defined as the actual cost of interest, taxes, insurance and mortgage insurance premiums, less the Project’s net operating income, for the period from the Project Substantial Completion Deadline through Project Substantial Completion, the calculation of which shall be approved by HUD. The lesser of the Liquidated Damages or Actual Damages shall be applied.

F. [**Applicable when an Incentive Payment Addendum is agreed to by the Parties**] The Parties have completed the appropriate blank spaces in Article 4 (Option 1 or Option 2) below with respect to “**Incentive Payment**,” providing for the payment of an additional sum to Contractor as an incentive for completing the Project earlier than

the Project Substantial Completion Deadline, or by such date to which the Project Substantial Completion Deadline may be extended by approved change order. If the Work is brought to Project Substantial Completion before the Project Substantial Completion Deadline, the contract sum stated in Article 4 (Option 1 or Option 2) below shall be increased, as indicated, by an Incentive Payment calculated in accordance with the Incentive Payment Addendum, consistent with Program Obligations. In cases requiring cost certification by Contractor, Contractor shall not be entitled to any Incentive Payment resulting from early completion if HUD determines that Contractor's cost certification is fraudulent or materially misrepresents Contractor's Actual Cost of Construction, as defined herein.

[Option 1] Article 4: Contract Sum -- Cost Plus Contract

A. Subject to the provisions hereinafter set out, Owner shall pay to Contractor for the performance of this Contract the following items in cash:

- (1) The Actual Cost of Construction as defined in Article 13 below; plus
- (2) Builder's Profit of \$ _____.

In no event, however, shall the total cash payable pursuant to this paragraph A exceed \$ _____.

B. In addition to any cash fee provided for in paragraph A, Owner shall pay to Contractor, by means other than cash, the following:

- (1) A promissory note in the form prescribed by HUD in the amount of \$ _____.
- (2) \$ _____ in the form of _____.

C. If Contractor shall have received cash payments in excess of (a) the Actual Cost of Construction plus (b) the Builder's Profit, plus any additional amount to be paid under the provisions of paragraph B, all such excess shall be refunded to Owner.

D. **[Applicable when an Incentive Payment Addendum is agreed to by the Parties]** Incentive Payment, where there is no Identity of Interest between Owner and Contractor:

- (1) If the Work is completed prior to the Project Substantial Completion Deadline, Owner shall make an incentive payment to Contractor. The amount of the payment shall be determined according to Exhibit ____, attached hereto, and consisting of page 2 of HUD-92443, entitled Incentive Payment Computation. Steps 1(a) and 3(b) thereof contain blanks that are to be filled in at the time this Contract is executed. *(Insert that portion of the sum of interest, taxes, insurance, and Mortgage Insurance Premium that appears in Section G of HUD-92264 attributable to the construction period. If there has been a change in the interest rate charged for the construction period (see footnote designated "***" on page 1 of HUD-92443), the dollar amount included in Section G of HUD-92264 must be adjusted. The adjusted amount must be reflected in the savings computation.)* Furthermore, the procedures set forth in footnote designated "***" on page 1 of HUD-92443 must be followed.

(2) If Contractor shall have received cash payments in excess of (a) the Actual Cost of Construction plus (b) the Builder's Profit, plus any additional amount to be paid under the provisions of paragraph B, plus the incentive payment under the provisions of paragraph D(1) above, all such excess shall be refunded to Owner.

(3) No incentive payment shall be allowed on savings in costs disallowed by HUD or if Contractor's cost certification is found by HUD to be either fraudulent or to materially misrepresent the Actual Cost of Construction.

E. [Applicable when an Incentive Payment Addendum is agreed to by the Parties] Incentive Payment, where there is an Identity of Interest between Owner and Contractor:

(1) The cash upset figure set forth at the end of paragraph A, immediately above is hereby increased by the amount by which \$_____ (the estimated sum of interest on the Loan, taxes, and property insurance and mortgage insurance premiums applicable to the construction period for this Project (See footnote designated "***" on page 1 of HUD-92443)) exceeds the Borrower's certified actual cost for these items through Project Substantial Completion, as approved by HUD, provided that construction is completed prior to the Project Substantial Completion Deadline, as amended by approved change order, and, further, that in no event shall the total cash payable exceed the Actual Cost of Construction as approved by HUD.

(2) If the aggregate interest rate during the construction period is determined at the time of cost certification to be less than that upon which the Note was endorsed, the estimated amount for interest, line 53 of HUD-92264, shall be adjusted accordingly and the dollar amount set forth in paragraph E(1) shall be reduced.

[Option 2] Article 4: Contract Sum -- Lump Sum Contract

A. Owner shall pay Contractor for the performance of this Contract, hereinafter provided, the sum of \$_____ (_____ and _____/100 dollars).

B. [Applicable when an Incentive Payment Addendum is agreed to by the Parties] Incentive Payment: If the Work is completed prior to the Project Substantial Completion Deadline, Owner shall pay to Contractor, in addition to the contract sum stated in paragraph A, an amount equal to ____% (not to exceed 50%) of the amount by which the sum of Owner's certified cost of interest, real estate taxes, insurance premiums and mortgage insurance premium during construction, as approved by HUD through Project Substantial Completion, is exceeded by HUD's estimates of these same items, which estimate is \$_____. *(Insert that portion of the sum of interest, taxes, insurance, and mortgage insurance premium that appears in Section G of HUD-*

92264 attributable to the construction period. If there has been a change in the interest rate charged for the construction period (See footnote designated “**” on page 1 of HUD-92443), the dollar amount included in Section G of HUD-92264 must be adjusted. The adjusted amount must be reflected in the savings computation.) No incentive payment shall be allowed on savings in costs disallowed by HUD or if Contractor’s cost certification is found by HUD to be either fraudulent or to materially misrepresent the Actual Cost of Construction.

Article 5: Requisition and Payment Procedures

A. Each month after the commencement of Work hereunder, Contractor shall make a monthly request on HUD-92448 for payment by Owner for Work done during the preceding month. Each request for payment shall be filed at least 15 days before the date payment is desired. Subject to the approval of Lender and HUD, Contractor shall be entitled to payment thereon in an amount equal to (1) the total value of classes of the Work acceptably completed; plus (2) the value of materials and equipment not incorporated in the Work, but delivered to and suitably stored at the site; plus (3) the value of components stored off-site in compliance with Program Obligations; less (4) ten (10) percent holdback [as this percentage may be reduced in accordance with the provisions of the Retainage Reduction Rider attached hereto, if applicable](or as reduced by HUD in writing) and less (5) prior payments. The “values” of (1), (2) and (3) shall be computed in accordance with the amounts assigned to classes of Work in HUD-92328.

B. With its final application for payment by Owner, Contractor shall disclose, on a form prescribed by HUD, all unpaid obligations contracted in connection with the Work performed under this Contract. Contractor agrees that within 15 days following receipt of final payment, it shall pay such obligations in cash and furnish satisfactory evidence of such payment to Owner.

C. The balance due to Contractor hereunder shall be payable upon the expiration of thirty (30) days after the Work hereunder is fully completed, provided the following have occurred: (1) all Work hereunder requiring inspection by Governmental Authorities having jurisdiction has been inspected and approved by such authorities and by the rating or inspection organization, bureau, association or office having jurisdiction; (2) all certificates of occupancy, or other approvals, with respect to the Project have been issued by Governmental Authorities; (3) Permission(s) to Occupy (HUD-92485) for all units of the Project have been issued by HUD; (4) where applicable, HUD shall have approved Contractor’s Certificate of Actual Cost; (5) as-built Drawings and Specifications, the as-built survey and all warranties shall have been delivered to Owner; and (6) all executed final advance documents required by HUD have been submitted.

Article 6: Receipts, Releases of Liens & Payments for Materials & Equipment

A. Contractor agrees that within fifteen (15) days following receipt of each monthly payment, it shall pay in full and in cash all obligations for Work done and

materials, equipment and fixtures furnished through the date covered by such monthly payment. Contractor may withhold retainage from the payment due each subcontractor, corresponding to, but not exceeding, the ten (10) percent holdback specified in item (4) of Article 5, paragraph A.

B. Owner may require Contractor to attach to each request for payment its acknowledgment of payment and all subcontractors' and material suppliers' acknowledgments of payment for Work done and materials, equipment and fixtures furnished through the date covered by the previous payment.

C. Contractor agrees that no materials or equipment required by the Specifications shall be purchased under a conditional sale contract or with the use of any security agreement or other vendor's title or lien retention instrument.

D. Concurrently with the final payment, Contractor shall execute a waiver or release of lien for all the Work performed and materials furnished hereunder, and Owner shall require Contractor to obtain similar waivers or releases from all subcontractors and material suppliers, if permitted by state law.

Article 7: Obligations of Contractor

A. Contractor shall furnish, at its own expense (or Owner's expense, if applicable), all building and other permits, licenses, tools, equipment and temporary structures necessary for the construction of the Project. Contractor shall give all required notices and shall comply with all applicable codes, laws, ordinances, rules and regulations, and protective covenants, wherever applicable. Contractor shall comply with the provisions of the Occupational Safety and Health Act of 1970. Contractor shall immediately notify Owner, Lender and HUD of the delivery of all permits, licenses, certificates of inspection, certificates of occupancy, and any other such certificates and instruments required by law, regardless of to whom issued, and shall cause them to be displayed to Owner, Lender and HUD upon request.

B. If Contractor observes that the Drawings and Specifications are at variance with any applicable codes, laws, ordinances, rules or regulations, or protective covenants, it shall promptly notify Architect in writing, and any necessary changes shall be made as provided in this Contract for changes in the Drawings and Specifications. If Contractor performs any Work knowing it to be contrary to such codes, laws, ordinances, rules or regulations, or protective covenants, without giving such notice to Architect, it shall bear all costs arising therefrom.

C. Upon completion of construction, Contractor shall furnish to Owner a land survey map prepared in accordance with Program Obligations, ALTA-NSPS standards and the HUD Surveyor's Report showing the location on the site of all improvements constructed thereon, and showing the location of all water, sewer, gas and electric lines and mains, and of all existing utility easements. Such survey map shall be prepared by a licensed surveyor who shall certify that the Work is installed and erected entirely upon the land covered by the Security Instrument and within any building restriction lines on said land, and does not overhang or otherwise encroach upon any easement or right-of-way of others. To the extent such data shows that the Contractor has deviated from the Plans and Specifications, Contractor shall be responsible, at its own expense (or Owner's expense, if applicable), for correcting any such deviations. In addition,

Contractor shall furnish additional surveys when Owner so requires, for any improvements, including structures and utilities not theretofore located on a survey.

D. Contractor shall assume full responsibility for the maintenance of all landscaping that may be required by the Drawings and Specifications until such time as both Parties to this Contract shall receive written notice from HUD that such landscaping has been finally completed. Owner hereby agrees to make available to the Contractor, for such purpose, without cost to the latter, such facilities as water, hose and sprinkler.

E. There shall be withheld from the final payment an amount satisfactory to Lender and HUD for any Work items that are incomplete at the time of such final payment.

Article 8: Assurance of Completion

Contractor shall furnish to Owner assurance of completion of the Work in the form of (specify) _____
_____. Such assurance of completion shall run to Owner and Lender as obligees and shall contain a provision whereby the surety agrees that any claim or right of action that either Owner or Lender might have thereunder may be assigned to HUD.

Article 9: Waiver of Lien or Claim

A. In jurisdictions where permitted by law, Contractor shall not file a mechanic's or materialman's lien or maintain any claim against Owner's Land or Improvements for or on account of any Work done, labor performed or materials furnished under this Contract, and shall include in each subcontract a clause which shall impose this requirement on the subcontractor.

B. In jurisdictions where permitted by law, Owner may require Contractor to execute a waiver of liens that shall be recorded prior to the commencement of construction. Contractor for itself, subcontractors, suppliers, materialmen, and all persons acting through or under it, agrees not to file or maintain mechanics' liens or claims against the property described herein, on account of Work done, labor performed or materials provided by them.

Article 10: Right of Entry

A. At all times during construction, HUD, Lender, and their agents or assigns shall have the right of entry and free access to the Project and the right to inspect all Work done and materials, equipment and fixtures furnished, installed or stored in and about the Project. For such purpose, Contractor shall furnish such enclosed working space as Lender or HUD may require and find acceptable as to location, size, accommodations and furnishings.

Article 11: Assignments, Subcontracts and Termination

A. This Contract shall not be assigned by either party without the prior written consent of the other party, Lender and HUD, except that Owner may assign this Contract, or any rights hereunder, to Lender or HUD.

B. Contractor shall not subcontract all of the Work to be performed hereunder without the prior written consent of Owner, Lender and HUD.

C. Upon request by Owner, Lender or HUD, Contractor shall disclose the names of all persons with whom it has contracted or will contract with respect to Work to be done and materials and equipment to be furnished hereunder.

D. Contractor understands that the Work under this Contract is to be financed by a building loan to be secured by a Security Instrument and insured by HUD, and that the terms of said Loan are set forth in a Building Loan Agreement between Owner as Borrower and _____ as Lender.

E. Contractor further understands that said Building Loan Agreement provides that, in the event of the failure of Owner to perform its obligations to Lender thereunder, Lender may, as attorney-in-fact for Owner, undertake the completion of the Project in accordance with this Contract. In the event Lender elects not to undertake such completion, this Contract shall terminate pursuant to AIA Document A201 § 14.2 in the case of termination for cause, or AIA Document A201 § 14.4 in the case of termination for convenience.

Article 12: Roles of HUD and Lender

HUD is the insurer of Lender's Loan made to finance the construction identified herein, pursuant to the Building Loan Agreement. Nothing provided herein, no action or inaction of the Parties to this Contract, or actions or inaction by any third parties, shall impute to HUD or Lender status as a party to this Contract; HUD and Lender have no liability to Contractor or Owner under the Contract Documents.

[Option 1] Article 13: Certification of Actual Cost -- Cost Plus Contract

A. The "**Actual Cost of Construction**" shall include all items of cost and expense incurred by Contractor in the performance of this Contract. Allowable items of cost and expense incurred by Contractor in the performance of this Contract shall include costs and expenses of labor, materials for construction, equipment and fixtures, field engineering, sales taxes, workmen's compensation insurance, social security, public liability insurance, general requirements and all other expenses directly connected with construction. The value of any kickbacks, rebates or discounts received or receivable in connection with the construction of the Project shall be subtracted from all items of cost and expense. Any cost or expense attributable to maintaining Contractor's working capital is not to be included within the Actual Cost of Construction.

B. Contractor shall keep accurate records of account of the Actual Cost of Construction, and shall, upon demand, make such records and invoices, receipts, subcontracts and other information pertaining to the construction of the Project available for inspection by Owner, Lender and HUD.

C. With its final application for payment, Contractor shall furnish to Owner a completed "**Contractor's Certificate of Actual Cost**" that shall be accompanied and

supported by an independent public accountant’s or independent certified public accountant’s certificate as to actual cost in form acceptable to HUD.

D. Contractor shall include in all subcontracts, equipment leases and purchase orders a provision requiring the subcontractor, equipment lessor or supplier to certify its costs incurred in connection with the Project, in the event HUD determines there is an Identity of Interest between either Owner or Contractor and any such subcontractor, equipment lessor or supplier.

[Option 2] Article 13: Cost Certification -- Lump Sum Contract

In the event HUD determines that there is an Identity of Interest between Contractor and Owner, Contractor shall certify, on a form prescribed by HUD, its cost incurred in the performance of the Work under this Contract.

Article 14: Designation of Representatives

A. Owner hereby designates _____ as its representative for all communications involving Work performed pursuant to this Contract.

B. Contractor hereby designates _____ as its representative for all communications involving Work to be performed pursuant to this Contract.

Article 15: Mediation and Non-binding Arbitration

Any mediated settlement agreement or non-binding arbitration agreement made pursuant to the General Conditions must be approved by HUD in writing before it will be effective.

Article 16: Headings and Titles

Any heading, section title, paragraph or part of this Contract is intended for convenience only, and is not intended, and shall not be construed, to enlarge, restrict, limit or affect in any way the construction, meaning, or application of the provisions thereunder, or under any other heading or title.

Article 17: Severability

The invalidity of any provision of this Contract shall not affect the validity of any other provision, and all other provisions shall remain in full force and effect.

IN WITNESS WHEREOF, the Parties to these presents have executed this Contract in counterparts, each of which shall be deemed an original.

CONTRACTOR _____
By (authorized agent): _____
Printed Name, Title: _____

Name of Entity: _____

OWNER _____

By (authorized agent): _____

Printed Name, Title: _____

Name of Entity: _____

Exhibit General Conditions

Exhibit HUD-92554M

Exhibit Drawings Index

Exhibit Specifications Index

Exhibit HUD-2328

Exhibit HUD-92443

Exhibit Prevailing Wage Determination

Exhibit Identities of Interest

Exhibit Retainage Reduction Rider

Public reporting burden for this collection of information is estimated to average 2 hours per response, including the time for reviewing instructions, searching existing data sources, gathering and maintaining the data needed, and completing and reviewing the collection of information. HUD may not collect this information, and you are not required to complete this form, unless it displays a currently valid OMB control number.

This information collection is necessary to ensure that viable projects are developed. It is important to obtain information from applicants to assist HUD in determining if nonprofit organizations initially funded continue to have the financial and administrative capacity needed to develop a project and that the project design meets the needs of the residents. The Department will use this information to determine if the project meets statutory requirements with respect to the development and operation of the project, as well as ensuring the continued marketability of the projects. This information is required in order to obtain benefits. This information is considered non-sensitive and no assurance of confidentiality is provided.

Privacy Act Notice: The United States Department of Housing and Urban Development, Federal Housing Administration, is authorized to solicit the information requested in the form by virtue of Title 12, United States Code, Section 1701 et seq., and regulations promulgated thereunder at Title 12, Code of Federal Regulations. While no assurance of confidentiality is pledged to respondents, HUD generally discloses this data only in response to a Freedom of Information Act request.

Know All Men By These Presents, That We,

of

as Principal, (hereinafter called the Principal) and _____, a

as Surety, (herinafter called the Surety) are held and firmly bound unto _____

Owner, (hereinafter called the "Owner-Obligee") and unto _____,

its successors and assigns, of _____ (hereinafter called the "Lender")

as their respective interests may appear, as OBLIGEES, in the sum of _____

Dollars (\$ _____), lawful money of the United States of America, for the payment of which Principal and Surety bind themselves, their heirs, executors, administrators, successors and assigns, jointly and severally, firmly by these presents.

WHEREAS, Principal has entered into a Construction Contract dated _____
with

Owner-Obligee for the construction of a Housing Project designated as _____

a copy of which Construction Contract is by reference made a part hereof; and

WHEREAS, Lender has agreed to lend to Owner-Obligee a sum of money to be secured by a mortgage on said project and to be used in making payments under said Contract, and desires protection as its interests may appear, in event of default by Principal under said Contract, said protection to be subject to the performance by the Obligees, or either of them, of the obligations to Principal in connection with said Contract.

NOW, THEREFORE, the condition of this obligation is such that, if Principal shall well and truly perform all the undertakings, covenants, terms, conditions and agreements of said Contract on its part, and fully indemnify and save harmless Obligees from all cost and damage which they may suffer by reason of failure so to do, and fully reimburse and repay Obligees all outlay and expense which Obligees may incur in making good any such default, then this obligation shall be null and void; otherwise it shall remain in full force and effect.

The foregoing, however, is subject to the following further provisions:

1. The Surety shall not be liable under this Bond to the Obligees, or either of them, unless the said Obligees, or either of them, shall make payments to the Principal strictly in accordance with the terms of said Contract as to payments, and shall perform all the other obligations to be performed under said Contract at the time and in the manner therein set forth.

2. Surety agrees that any right of action that either of Obligees herein might have under this bond may be assigned to the Secretary of Housing and Urban Development, acting by and through the Federal Housing Commissioner, and that such assignment will in no manner invalidate or qualify this instrument.

3. No suit, action, or proceeding by reason of any default whatever shall be brought on this bond after two years from the day on which the final payment under the Contract falls due.

4. The prior written approval of Surety shall be required with regard to any changes or alterations in said Contract where the cost thereof, added to prior changes or alterations, causes the aggregate cost of all changes and alterations to exceed 10 percent of the original Contract price; but, except as to the foregoing, any alterations which may be made in the terms of the Contract, or in the work to be done under it, or the giving by the Obligees of any extension of time for the performance of the Contract, or any other forbearance on the part of either the Obligees or Principal to the other, shall not in any way release Surety or Principal of the obligations of this instrument, notice to Surety of any such alteration, extension, or forbearance being hereby waived.

5. The aggregate liability of Surety hereunder to the Obligees or their assigns is limited to the penal sum above stated, and Surety, upon making any payment hereunder, shall be subrogated to, and shall be entitled to an assignment of, all rights of the payee, either against Principal or against any other party liable to the payee in connection with the loss which is the subject of the payment.

SIGNED and SEALED this _____ day of _____ 20____

Witness as to Principal _____ (Principal) (SEAL)

_____ By _____

_____ (Surety)

By _____

\$ _____

(Surety)

PERFORMANCE BOND-DUAL OBLIGEE

No. _____

On Behalf of

Date _____, 20_____

Expires _____, 20_____

If collecting SSN or EIN:

Privacy Act Statement: The Department of Housing and Urban Development is authorized to collect this information by the National Housing Act, Section 235(b), P.L. 479, 48 Stat. 12 U.S.C. 1701 et seq. HUD is authorized to collect the Social Security Number (SSN) by Section 165(a) of the Housing and Community Development Act of 1987, P.L. 100-242, and by Section 904 of the Stewart B. McKinney Homeless Assistance Amendments Act of 1988, P.L. 100-628. The information is being collected to determine the amount of assistance (if any) the applicant is entitled. The information is also used as a tool for managing the program(s) related to this form, and for protecting the Government's financial interests. **The information may be used to conduct computer-matching programs to check for underreported or unreported income.** The SSN is used as a unique identifier. The information may be released to appropriate Federal, State, and local agencies, and when relevant, to civil, criminal, or regulatory investigators and/or prosecutors. This information will not be otherwise disclosed or released outside of HUD except as permitted or required by law. It is mandatory that you provide all of the requested information, including all SSN(s), for you and all other household members age six years and older. Failure to provide SSN(s) and required documents will result in a delay or loss of assistance payments.

If not collecting SSN or EIN:

Privacy Act Notice: The United States Department of Housing and Urban Development, Federal Housing Administration, is authorized to solicit the information requested in the form by virtue of Title 12, United States Code, Section 1701 et seq., and regulations promulgated thereunder at Title 12, Code of Federal Regulations. While no assurance of confidentiality is pledged to respondents, HUD generally discloses this data only in response to a Freedom of Information Act request.

Contractor's and/or Mortgagor's Cost Breakdown Schedules of Values

**U.S. Department of Housing and
Urban Development**
Office of Housing
Federal Housing Commissioner

OMB No. 2502-0044 (exp.12/31/2018)

Public reporting burden for this collection of information is estimated to average 4 hours per response, including the time for reviewing instructions, searching existing data sources, gathering and maintaining the data needed, and completing and reviewing the collection of information. This information is required to obtain benefits. HUD may not collect this information, and you are not required to complete this form, unless it displays a currently valid OMB Control Number.

Section 207 of the National Housing Act (Section 126 of the Housing Act of 1954, Public Law 560, 12 U.S.C., 1715r), authorizes the collection of this information. The information is required for a general contractor when an identity of interest exists between the general contractor and the mortgagor or when the mortgagor is a non-profit entity and a cost plus contract has been used. The information is used by HUD to facilitate the advances of mortgage proceeds and their monitoring.

Privacy Act Notice. The United States Department of Housing and Urban Development, Federal Housing Administration, is authorized to solicit the information requested in this form by virtue of Title 12, United States Code, Section 1701 et seq., and regulations promulgated thereunder at Title 12, Code of Federal Regulations. While no assurances of confidentiality is pledged to respondents, HUD generally discloses this data only in response to a Freedom of Information request.

Date	Sponsor
Project No.	Building Identification
Name of Project	Location

This form represents the Contractors and/or Mortgagors firm costs and services as a basis for disbursing dollar amounts when insured advances are requested. Detailed instructions for completing this form are included on the reverse side.

Line	Div.	Trade Item	Cost	Trade Description
1	3	Concrete		
2	4	Masonry		
3	5	Metals		
4	6	Rough Carpentry		
5	6	Finish Carpentry		
6	7	Waterproofing		
7	7	Insulation		
8	7	Roofing		
9	7	Sheet Metal		
10	8	Doors		
11	8	Windows		
12	8	Glass		
13	9	Lath and Plaster		
14	9	Drywall		
15	9	Tile Work		
16	9	Acoustical		
17	9	Wood Flooring		
18	9	Resilient Flooring		
19	9	Painting and Decorating		
20	10	Specialties		
21	11	Special Equipment		
22	11	Cabinets		
23	11	Appliances		
24	12	Blinds and Shades, Artwork		
25	12	Carpets		
26	13	Special Construction		
27	14	Elevators		
28	15	Plumbing and Hot Water		
29	15	Heat and Ventilation		
30	15	Air Conditioning		
31	16	Electrical		
32		Subtotal (Structures)		
33		Accessory Structures		
34		Total (Lines 32 and 33)		

Line	Div.	Trade Item	Cost	Trade Description			
35	2	Earth Work					
36	2	Site Utilities					
37	2	Roads and Walks					
38	2	Site Improvements					
39	2	Lawns and Planting					
40	2	Unusual Site Condition		Nonresidential and Special Exterior Land Improvement (costs included in trade item breakdown)		Offsite Costs (costs not included in trade item breakdown)	
41		Total Land Improvements					
42		Total Struct. & Land Imprvts.		Description	Est. Cost	Description	Est. Cost
43	1	General Requirements					
44		Subtotal (Lines 42 and 43)					
45		Builder's Overhead					
46		Builder's Profit		Total \$			
47		Subtotal (Lines 44 thru 46)		Other Fees		Total \$	
48						Demolition (costs not included in trade item breakdown)	
49		Other Fees					
50		Bond Premium				Description	Est. Cost
51		Total for All Improvements					
52		Builder's Profit Paid by Means Other Than Cash					
53		Total for All Improvements Less Line 52		Total \$		Total \$	

I hereby certify that all the information stated herein, as well as any information provided in the accompaniment herewith, is true and accurate.

Warning: HUD will prosecute false claims and statements. Conviction may result in criminal and/or civil penalties. (18 U.S.C. 1001, 1010, 1012; 31 U.S.C. 3729, 3802)

Mortgagor		By		Date
Contractor		By		Date
FHA (Processing Analyst)	Date	FHA (Chief, Cost Branch or Cost Analyst)	Date	
FHA (Chief Underwriter)			Date	

Instructions for Completing Form HUD-2328

This form is prepared by the contractor and/or mortgagor as a requirement for the issuance of a firm commitment. The firm replacement cost of the project also serves as a basis for the disbursement of dollar amounts when insured advances are requested. A detailed breakdown of trade items is provided along with spaces to enter dollar amounts and trade descriptions.

A separate form is prepared through line 32 for each **structure type**. A summation of these structure costs are entered on line 32 of a master form. Land improvements, General Requirements and Fees are completed through line 53 on the master 2328 **only**.

Date—Date form was prepared.

Sponsor—Name of sponsor or sponsoring organization.

Project No.—Eight-digit assigned project number.

Building Identification—Number(s) or Letter(s) of each building as designated on plans.

Name of Project—Sponsors designated name of project.

Location—Street address, city and state.

Division—Division numbers and trade items have been developed from the cost accounting section of the uniform system.

Accessory Structures—This item reflects structures, such as: community, storage, maintenance, mechanical, laundry and project office buildings. Also included are garages and carports or other buildings.

When the amount shown on line 33 is \$20,000.00 or 2% of line 32 whichever is the lesser, a separate form HUD-2328 will be prepared through line 32 for Accessory Structures.

Unusual Site Conditions—This trade item reflects rock excavation, high water table, excessive cut and fill, retaining walls, erosion, poor drainage and other on-site conditions considered unusual.

Cost—Enter the cost being submitted by the Contractor or bids submitted by a qualified subcontractor for each trade item. These costs will include, as a minimum, prevailing wage rates as determined by the Secretary of Labor.

Trade Description—Enter a brief description of the work included in each trade item.

Other Fees—Includable are fees to be paid by the Contractor, such as sewer tap fees not included in the plumbing contract. Fees paid or to be paid by the Mortgagor are not to be included on this form.

Total For All Improvements—This is the sum of lines 1 through 50 and is to include the total builder's profit (line 46).

Line 52—When applicable, enter that portion of the builder's profit (line 46) to be paid by means other than cash and/or any part of the builder's profit to be waived during construction.

Non-Residential and Special Exterior Land Improvement Costs—Describe and enter the cost of each improvement, i.e. on-site parking facilities including individual garages and carports, commercial facilities, swimming pools with related facilities and on-site features provided to enhance the environment and livability of the project and the neighborhood. The Design Representative and Cost Analyst shall collaborate with the mortgagor or his representative in designating the items to be included.

Off-Site Costs—Enter description and dollar amount including fees and bond premium for off-site improvements.

Demolition—Enter description and dollar amount of demolition work necessary to condition site for building improvements including the removal of existing structures, foundations, utilities, etc.

Other Fees—Enter a brief description of item involved and cost estimate for each item.

Signatures—Enter the firm name, signature of authorized officer of the contractor and/or mortgagor and date the form was completed.

Request for Construction Changes on Project Mortgages

U.S. Department of Housing and Urban Development
Office of Housing
Federal Housing Commissioner

OMB Approval No. 2502-0011 (exp. 1/31/2020)

No changes in the drawings and specifications may be effected unless a completed request for construction changes has been filed and approved by HUD in accordance with the Construction Contract. **Read the instructions & Public Burden statement on the back of this form.**

Name and location of this project	Request No.(HUD use only)	Project Number
-----------------------------------	---------------------------	----------------

Name of Contractor	Name of Mortgagor	Name of Mortgagee
--------------------	-------------------	-------------------

To the Federal Housing Commissioner: You are requested to consider the following proposed changes in the project. The changes are satisfactory to the parties hereto, as indicated by the signatures below.

Description of Changes	Mortgagor Estimated Effect on Cost + or -	HUD Estimated Effect on Cost + or -	V = Acceptable O = Unacceptable	
			Arch.	Val.
a.				
b.				
c.				
d.				
e.				
f.				
g.				
h.				
i.				
j.				
k.				
l.				
m.				

Amount on deposit with mortgagee to cover increased cost of changes pursuant to conditions of Request No. _____ \$	Total \$	Initial & Date	Initial&Date	Initial&Date
--	----------	----------------	--------------	--------------

I certify that I have no financial interest in this project beyond the fee for my professional services, and that I have no interest with the mortgagor, contractor, or any subcontractor or supplier. The changes set forth in this request conform to the intent of the contract documents and I recommend that the changes be approved.

Contractor (signature)	Mortgagor (signature)	Mortgagee (signature)
------------------------	-----------------------	-----------------------

The following is required on requests involving cooperatives and non-profit mortgagors with respect to any increase or decrease in cost resulting from acceptable changes: (check appropriate box.)

- The abovesigned contractor agrees to assume any additional costs and agrees that he will not assert any claim against the Mortgagor in connection therewith.
- The abovesigned Mortgagor, acting pursuant to a resolution adopted at a meeting of its stockholders or members, and the abovesigned Contractor, agree to the above described construction changes and agree that the construction contract executed by them (date) _____ is amended by increasing the contract price of \$ _____ set forth in Article 3 thereof to \$ _____ all other provisions of the Construction Contract remain unchanged.
- The abovesigned Mortgagor and the above signed Contractor agree to the construction changes described above and agree that the construction contract executed by them (date) _____ is amended by decreasing the contract price of \$ _____ set forth in Article 3 thereof to \$ _____ ; all other provisions of the construction contract remain unchanged.

Federal Housing Commissioner Findings:			1. Mortgagor's Estimate				2. Net effect on Construction Costs			
a. Effect on cost of previously accepted changes \$	b. Effect on cost to date of all changes \$	c. Percent %	a. Present changes \$	b. Previous changes \$	c. Total \$	d. Percent %				
			<input type="checkbox"/> Increase <input type="checkbox"/> Decrease		<input type="checkbox"/> Increase <input type="checkbox"/> Decrease		<input type="checkbox"/> Increase <input type="checkbox"/> Decrease			

3. Changes _____ are acceptable and the drawings and specifications amended, provided:
- a. That a total sum of \$ _____ is on deposit with the mortgage to cover net increase in cost resulting from present and previous construction changes. This supersedes any previous requirements. The money will not be released without written consent of HUD prior to final completion and acceptance of the project construction. No further advances of the mortgage proceeds under the Building Loan Agreement will be approved unless the total sum is on deposit with you.
 - b. That in order to reflect the net decrease in cost or reduction in mortgage based on net income or number of family units, resulting from acceptable present and previous construction changes, the amount of \$ _____ shall be deducted from the amount entered on the line entitled "Sum of Cost Breakdown Items Plus Inventories of Materials", form HUD-92448. This amount may be modified by later changes.
 - c. Consent of surety to these changes is obtained in writing and a signed copy sent to this office prior to effecting the change.
 - d. There is compliance with the conditions stated on the back of this form.

4. <input type="checkbox"/> Changes _____ are not acceptable. See "Reasons for Unacceptability" on the back of this form.	Mortgage Credit Initial & Date
--	--------------------------------

HUD analysis and findings reviewed and approved: Director, Housing Development Division (signature)	Date	Federal Housing Commissioner Signature of authorized agent
--	------	---

Public Reporting Burden for this collection is estimated to average 2 hours per response, including the time for reviewing, searching existing data sources, gathering and maintaining the data needed, and compiling and reviewing the collection of information. Send comments regarding this burden estimate or any other aspect of this collection of information, including suggestions for reducing this burden to the Reports Management Officer, Paperwork Reduction Project (2502-0011), U.S. Department of Housing and Urban Development, 451 7th Street SW, Washington, DC 20410-3600.

The Department of Housing and Urban Development (HUD) is authorized to collect this information by provisions set forth in Section 5 of the United States Housing Act of 1937, as amended. It is provided by contractors, mortgagors and mortgagees to obtain the FHA Commissioner's approval of changes in contract drawings and specifications, and this information is used to ensure that viable projects are developed. This information is used by HUD to ensure that viable projects are being developed. Furnishing of this information is mandatory, and failure to provide it may result in your not receiving your benefits.

Privacy Act Notice. The United States Department of Housing and Urban Development, Federal Housing Administration, is authorized to solicit the information requested in this form by virtue of Title 12, United States Code, Section 1701 et seq., and regulations promulgated thereunder at Title 12, Code of Federal Regulations. While no assurances of confidentiality is pledged to respondents, HUD generally discloses this data only in response to a Freedom of Information request. This agency may not conduct or sponsor, and a person is not required to respond to, a collection of information unless that collection displays a valid OMB control number.

Instructions

Send the original and six copies to HUD through the mortgagee.

Under "Description of Changes" describe each proposed change and enter the amount by which the construction cost will be increased or decreased as the net result of each proposed change. Attach documentation including (1) reason for each change, (2) general scope, (3) full detailed description of work to be omitted and/or added and the cost for each trade affected, and (4) reference any attachments showing proposed revisions.

Estimate the cost of each change on the basis of the current cost of items omitted, substituted or added. Estimates include job overhead and builder's fee, or job overhead and general overhead, as applied in the HUD estimate of the project. No allowance for "Builder's and Sponsor's Profit and Risk" is included. No architect's or engineer's fee is included.

This form is not used for off-site changes. Such changes must be submitted in writing, using this form as a guide.

To be acceptable to HUD a proposed change must be due to necessity, or be an appropriate betterment, or qualify as an equivalent. In accepting any changes, it is assumed that they will be executed. If an accepted change is not executed, it must be nullified by substituting a Request for Construction Changes amending the drawings and specifications so as to restore the drawings and specifications to prior status or to a status acceptable to HUD.

Send requests for a time extension on a separate form.

Conditions of Acceptance or Reasons for Unacceptability

When the HUD estimated cost of all accepted changes results in a net decrease in the total construction cost, the insurable mortgage will be similarly decreased; but if the net effect is an increase, the additional costs will be defrayed by the mortgagor. The acceptance of any change or changes involving a net increase does not increase the mortgage amount.

Contractor's Requisition Project Mortgages

U.S. Department of Housing and Urban Development OMB Approval No. 2502-0028 (Exp. 09/30/2022)
Office of Housing
Federal Housing Commissioner

To be submitted to mortgagee in quadruplicate

This information is used to verify program benefits consisting of distribution of insured mortgage proceeds when construction costs are involved. The information regarding completed work items is used by HUD to ensure that payments from mortgage proceeds are made for work actually completed in a satisfactory manner. This information is a requirement under Section 207(b) of the National Housing Act (Public Law 479, 48 Stat. 1246, 12 U.S.C. 1701 et. seq) authorizing the Secretary of HUD to insure mortgages. The information collection does not contain information of a sensitive nature.

Public reporting burden for this collection of information is estimated to average 6 hours per response, including the time for reviewing instructions, searching existing data sources, gathering and maintaining the data needed, and completing and reviewing the collection of information. This agency may not collect this information, and you are not required to complete this form, unless it displays a currently valid OMB control number.

To (owner)		Requisition Number	
Project	Project Number	Location	

In accordance with the provision of the Construction Contract dated _____ and Contractor's and/or Mortgagor's Cost Breakdown (Schedule of Values) attached thereto, this requisition is submitted for the amount of \$ _____ due for work performed up to the _____ day of _____ and as itemized below by the trades listed in the Schedule of Values.

DIV	Trade Item	Cost as per Cost Breakdown (A)	Enter Amounts to Nearest Even Dollar	
			Amounts Complete (B)	For HUD-FHA Use
				(C)
3	Concrete	\$	\$	\$
4	Masonry			
5	Metals			
6	Rough Carpentry			
6	Finish Carpentry			
7	Waterproofing			
7	Insulation			
7	Roofing			
7	Sheet Metal			
8	Doors			
8	Windows			
8	Glass			
9	Lath and Plaster			
9	Drywall			
9	Tile Work			
9	Acoustical			
9	Wood Flooring			
9	Resilient Flooring			
9	Painting and Decorating			
10	Specialties			
11	Special Equipment			
11	Cabinets			
11	Appliances			
12	Blinds and Shades, Artwork			
12	Carpets			
13	Special Construction			
14	Elevators			
15	Plumbing and Hot Water			
15	Heat and Ventilation			
15	Air Conditioning			
16	Electrical			
	Accessory Buildings			
2	Earth Work			
2	Site Utilities			
2	Roads and Walks			
2	Site Improvement			
2	Lawns and Planting			
2	Unusual Site Conditions			
1	General Requirements			
1	Bond Premium (\$ _____)			

DIV	Trade Item	Cost as per Cost Breakdown (A)	Enter Amounts to Nearest Even Dollar							
			Amounts Complete (B)			For HUD-FHA Use (C)				
1	Other Fees (\$)									
(1)	Subtotal of Breakdown Items	\$ 0	*	%	\$ 0	**	%	\$		
(2)	Builder's Overhead	\$		%	\$		%	\$		
(3)	Builder's Profit	\$		%	\$		%	\$		
(4)	Total of Cost Breakdown Items	\$			\$			\$		
(5)	Inventory of Materials Stored On-site (See Note Below)				\$			\$		
(6)	Inventory of Materials Stored Off-Site (See Note Below)				\$			\$		
(7)	Sum of Cost Breakdown Items Plus Inventories of Materials				\$			\$		
(8)	Less Net Decrease in Cost as a Result of Approved Changes				\$			\$		
(9)	Total After Adjusting for Net Decrease to Approved Changes				\$			\$		
(10)	Less Retained 10%				\$			\$		
(11)	Bal.: Total Amount Due to Date on Account of Construction Contract				\$			\$		
(12)	Less Previous Payments				\$			\$		
(13)	Net Amount of This Requisition				\$			\$		

I certify that the Work covered by this requisition has been completed in accordance with the Contract Documents, and that I have actually received \$_____ for Work performed and materials purchased up to the _____ day of _____ (date of previous requisition).

For Use of HUD-Federal Housing Commissioner

Date	Net Amount Approved for Payment	Column C Completed by (Mortgage Credit Examiner)
Reviewed and Approved by (Chief, Mortgage Credit)	Director, Housing Development	

Architect's Certificate I certify, based on my on-site observations (or those of my authorized representative) and the data comprising this requisition, that the Work has progressed to the point indicated; that to the best of my knowledge, information and belief the Work is in accordance with the Contract Documents; and that the Contractor is entitled to payment of the amount certified.

Date _____ Architect _____

Inspector's Certificate Amount Modified No Modification

I certify that I have visited the site on this date _____, observed the Work, and monitored the log and reports of the Architect (if an architect is administering the Construction Contract); that to the best of my knowledge, information and belief the amount certified represents acceptable Work; and that I have no personal interest, present or prospective, in the property, applicant or proceeds of the mortgage.

Date _____ Inspector _____

Contractor's Prevailing Wage Certificate (For use under all sections of the National Housing Act requiring certification as to payment of prevailing wages. To be completed with each request for insurance of advance of mortgage proceeds which includes a payment on account of construction cost, or at the time the mortgage is presented for insurance pursuant to a commitment to insure upon completion.)

Manager	Project Name
Field Office	Project Number

The undersigned, as principal contractor in connection with the construction of the above project, states that he/she is fully familiar with applicable wage determination decision of the Secretary of Labor and certifies that:

- A copy of the applicable wage determination decision is posted in a conspicuous place at the site of the work and he/she has required each subcontractor as a part of his/her contract, to agree to pay wages at rates not less than those contained in the decision.
- All laborers and mechanics employed in the construction of the project have been, to the date hereof, paid for such employment at wage rates not less than those contained in the applicable wage determination decision of the Secretary of Labor and no deductions or rebates have been made, either directly or indirectly, from the full weekly wages earned by any person, other than permissible deductions as defined in Regulations of the Secretary of Labor, Part 3 (29 CFR Part 3).
- He/She has fulfilled his/her obligations, to the date hereof, under The Labor Standards Provisions of the Supplementary Conditions of the Contract for Construction and has included said conditions in all subcontracts.

This certificate is executed by the undersigned for the purpose of inducing the Commissioner to approve for insurance that certain mortgage loan, or an advance thereof, made or to be made by the mortgagee in connection with the construction of the project, and with the intent that the Commissioner rely upon this certification to establish compliance with the provisions of Section 212 of the National Housing Act, which provides in part: The Commissioner shall not insure ... unless the principal contractor files a certificate ... certifying that the laborers and mechanics ... have not been paid not less than the wages prevailing ... as determined by the Secretary of Labor..."

I hereby certify that all the information stated herein, as well as any information provided in the accompaniment herewith, is true and accurate.

Warning: HUD will prosecute false claims and statements. Conviction may result in criminal and/or civil penalties (18 U.S.C. 1001, 1010, 1012; 31 U.S.C. 329, 3802).

Contractor _____ By _____ Date: _____

Building Loan Agreement

U.S. Department of Housing and
Urban Development
Office of Housing

OMB Approval No. 2502-0598
(Exp. 9/30/2021)

Public Reporting Burden for this collection of information is estimated to average 1 hour per response, including the time for reviewing instructions, searching existing data sources, gathering and maintaining the data needed, and completing and reviewing the collection of information. Response to this request for information is required in order to receive the benefits to be derived. This agency may not collect this information, and you are not required to complete this form unless it displays a currently valid OMB control number. While no assurance of confidentiality is pledged to respondents, HUD generally discloses this data only in response to a Freedom of Information Act request.

Warning: Federal law provides that anyone who knowingly or willfully submits (or causes to submit) a document containing any false, fictitious, misleading, or fraudulent statement/certification or entry may be criminally prosecuted and may incur civil administrative liability. Penalties upon conviction can include a fine and imprisonment, as provided pursuant to applicable law, which includes, but is not limited to, 18 U.S.C. 1001, 1010, 1012; 31 U.S.C. 3729, 3802, 24 C.F.R. Parts 25, 28 and 30, and 2 C.F.R. Parts 180 and 2424.

HUD Project Number:

Project Name:

THIS BUILDING LOAN AGREEMENT, made this _____ day of _____
20____, by and between _____, a
_____ organized and existing under the laws of
_____ with an office and place of business in
_____, County of _____, and State of
_____ ("**Borrower**"), and _____, a _____
organized and existing under the laws of _____, having an office and
place of business at _____ [City] [County] of
_____ and State of _____ ("**Lender**"). (The definition
of any capitalized term or word used herein can be found in this Building Loan
Agreement, the Regulatory Agreement between Borrower and HUD, the Note, and/or
the Security Instrument, except that the term "**Program Obligations**" means (1) all
applicable statutes and any regulations issued by the Secretary pursuant thereto that
apply to the Project, including all amendments to such statutes and regulations, as they
become effective, except that changes subject to notice and comment rulemaking shall
become effective only upon completion of the rulemaking process, and (2) all current
requirements in HUD handbooks and guides, notices, and mortgagee letters that apply
to the Project, and all future updates, changes and amendments thereto, as they
become effective, except that changes subject to notice and comment rulemaking shall
become effective only upon completion of the rulemaking process, and provided that
such future updates, changes and amendments shall be applicable to the Project only
to the extent that they interpret, clarify and implement terms in this Building Loan
Agreement rather than add or delete provisions from such document. Handbooks,
guides, notices, and mortgagee letters are available on "HUDCLIPS," at www.hud.gov

WHEREAS, Borrower, as the owner in fee simple of, or the owner of the leasehold estate in, the land (“**Land**”) described in Exhibit A attached to the **Security Instrument**, which Exhibit A is also attached hereto and incorporated herein by reference, has obtained a commitment from Lender for a Loan of

_____ Dollars (\$ _____) to aid Borrower in the construction or rehabilitation on said Land of a Project identified above in accordance with Drawings and Specifications hereinafter referred to, and

WHEREAS, Borrower understands that Lender has received a Firm Commitment from **HUD** for insurance of said Loan under the provisions of the National Housing Act, as amended, and intends upon execution of the hereinafter mentioned Note and Security Instrument to have the Note endorsed for insurance by HUD. (HUD is not making the Loan.)

NOW, THEREFORE, in consideration of the mutual promises hereinafter set out and of other valuable consideration, the receipt of which is hereby acknowledged, the undersigned agree as follows:

(1) Lender shall make and Borrower shall obtain a Loan in the principal sum of _____ Dollars (\$ _____), to be advanced as hereinafter provided, and to bear interest from the date of each advance at the rate of _____ percent (_____ %) per annum. The Loan shall be evidenced by a credit instrument (“**Note**”) dated _____ 20____. The Note shall be payable in monthly installments, and shall have a maturity date of _____, 20____. The Note shall be executed by Borrower and payable to Lender, or order, and shall be secured by a Security Instrument, of even date, on the Land described in the Security Instrument. The Security Instrument shall constitute a valid first lien on said Land and the Improvements to be erected thereon, and the only lien thereon except for liens for taxes and assessments not yet payable and other liens acceptable to Lender and HUD. Lender shall not advance any Loan funds until Borrower and Lender have submitted to HUD documents required by this Building Loan Agreement and the Firm Commitment to insure advances, and not until HUD has completed the initial endorsement of the Note.

(2) Borrower shall complete, on the Land, by _____ 20____, a Project in accordance with Drawings and Specifications filed with HUD dated _____, last revised _____. Such Drawings and Specifications, which include General Conditions of the Contract for Construction, AIA Document A201 – _____ {**Insert year of current edition**} (“**General Conditions**”) and the Supplementary Conditions of the Contract for Construction (HUD-92554M), have been initialed by Borrower, Design Architect, Architect administering the Construction Contract (“**Architect**”), the Contractor, the Lender (if applicable), and Contractor’s surety or guarantor (if applicable).

(3) Changes in the Drawings and Specifications, or changes by altering or adding to the work contemplated, or orders for extra work shall have the prior written approval of

the Architect. In addition, any such change or order may be effected only with the prior written approval of Lender and HUD and under such conditions as either Lender or HUD may establish.

(4) (a) Borrower shall make monthly applications on HUD-92403 for advances of Loan proceeds from Lender. Applications for advances with respect to construction items shall be for amounts equal to (i) the total value of classes of the work acceptably completed; plus (ii) the value of materials and equipment not incorporated in the work, but delivered to and suitably stored at the site, plus (iii) the value of components stored off-site in compliance with Program Obligations; less (iv) ten percent (10%) (“**Holdback**”) [as this percentage may be reduced in accordance with the provisions of the Retainage Reduction Rider attached hereto, if applicable] and (v) less prior advances. The values of (i), (ii) and (iii) shall be computed in accordance with the amounts assigned to classes of the work in the Contractor’s and/or Mortgagor’s Cost Breakdown (HUD-2328) attached to the Construction Contract and also attached hereto as Exhibit B. Each application shall be filed at least fifteen (15) days before the date the advance is desired, and Borrower shall be entitled thereon only to such amount as may be approved by Lender (and HUD, pursuant to Program Obligations).

(b) Upon completion of the Improvements, including all landscape requirements, off-site utilities and streets, and any incomplete construction work as described in the Escrow Agreement for Incomplete Construction, Borrower shall furnish to Lender and HUD satisfactory evidence that all work requiring inspection by the Property Jurisdiction has been duly inspected and approved by such authorities and by the rating or inspection organization, bureau, association or office having jurisdiction; and that all requisite certificates of occupancy and other approvals to own and operate the Project have been issued. The balance due Borrower hereunder shall be payable at such time after completion as HUD authorizes the release of the final advance. However, Lender may withhold final payment until after the expiration of any period that mechanics and materialmen may have for filing liens.

(c) Except as otherwise provided by Program Obligations, Borrower agrees to deposit with Lender cash in the amount of \$ _____, an amount that has been deemed by HUD to be sufficient, when added to the proceeds of the Loan, to assure completion of the Project and to pay the initial service charge, carrying charges, and legal and organizational expenses incident to the construction of the Project (“**Project Completion Funds**”). Borrower agrees that Project Completion Funds shall be advanced by Lender as set forth in the disbursement agreement dated _____, 20____, approved by Lender and HUD and attached hereto as Exhibit C. Borrower further agrees that Project Completion Funds shall be advanced prior to Loan Proceeds, except as otherwise permitted by Program Obligations and reflected in the disbursement agreement.

(d) Borrower covenants that it shall hold in trust each advance hereunder for application to the items for which such advance was requested and approved.

(e) Except as otherwise provided in Program Obligations, Borrower agrees that the Loan shall at all times remain in balance. Lender shall, in accordance with the provisions of this Building Loan Agreement, continue to advance to Borrower funds out of the proceeds of the Loan upon insurance thereof by HUD, as long as the Loan

remains in balance and Borrower is not in default hereunder or under the Note or Security Instrument.

(5) Lender shall advance to Borrower out of the funds referred to in (4)(c) above, or out of the proceeds of the Loan, amounts for application to the charges or items set forth in a rider to the disbursement agreement (Exhibit C), but only to the extent that such charges have accrued, or that Borrower is otherwise entitled to payment on account of such items. If there is no disbursement agreement, then the amounts for application to the charges or items shall be set forth in a schedule attached as Exhibit C.

TOTAL MAXIMUM ADVANCE (Line 45 of Financial Requirements for Closing (HUD-2283)) \$_____

(6) Borrower shall cause either this instrument, waiver of liens or the Construction Contract under which the Improvements are to be erected (or a memorandum thereof) to be filed in the public records, if the effect thereof shall be to relieve the Mortgaged Property from mechanics' and materialmen's liens. Before any advance hereunder, Lender may require Borrower to obtain from the Contractor and all subcontractors and materialmen dealing directly with the principal Contractor acknowledgments of payment and releases of lien down to the date covered by the last advance, and concurrently with the final payment for the entire Project. Such acknowledgments and releases shall be in the form required by local lien laws and shall cover all work done, labor performed and materials (including equipment and fixtures) furnished for the Project.

(7) Borrower shall, as a condition precedent to the first advance hereunder, furnish Lender with a signed, sealed and certified, current survey of the Mortgaged Property and a Lender's title insurance policy (or other evidence of title) in form, substance and amount satisfactory to Lender and HUD. Said policy (or other title evidence) shall be endorsed so as to cover each and every advance of said Loan at the time of payment thereof and shall show no mechanics' or materialmen's liens against the Mortgaged Property. Borrower shall furnish duplicate originals of said survey and title policy (or title evidence) to HUD.

(8) Borrower agrees that the Project shall be constructed strictly in accordance with all applicable ordinances and statutes, and in accordance with the requirements of all regulatory authorities, and any rating or inspection organization, bureau, association or office having jurisdiction. Borrower further agrees that the Project shall be constructed in accordance with the Drawings and Specifications (including any drawings and specifications for off-site improvements) and shall not encroach upon any easement or right-of-way, or the land of others; and that the buildings when erected shall be wholly within the building restriction lines however established, and shall not violate applicable use or other restrictions contained in prior conveyances, zoning ordinances or regulations. Borrower shall furnish from time to time such evidence with respect thereto as may be required by Lender or HUD and, upon completion of construction, shall furnish a survey, signed, sealed and certified by a registered surveyor that shows the

Project to be entirely on the Land, except for off-site improvements approved by Lender and HUD, and to be free from any such violations.

(9) The Borrower shall have defaulted under this Building Loan Agreement, if, at any time prior to the completion of construction: (a) Borrower ceases work on the Project for a period of more than twenty (20) days; (b) Borrower fails to complete the erection of the Project substantially in accordance with the Drawings and Specifications within the time period permitted hereunder, as such time period may be extended with the consent of Lender and HUD; (c) Borrower makes changes in the Drawings and Specifications without first securing the written approval required by paragraph 3 hereof; (d) Borrower otherwise fails to comply with the terms of this Building Loan Agreement without first obtaining the written approval of HUD; or (e) an Event of Default occurs under the Security Instrument. In the event of any such default under this Building Loan Agreement, Lender may, at its option, terminate this Building Loan Agreement or terminate its obligation to make further advances under this Building Loan Agreement; in either such event Lender may use and apply any funds deposited with it by Borrower, regardless of the purpose for which such funds were deposited, in such manner and for such purposes as HUD may prescribe. Regardless of whether Lender elects to terminate this Building Loan Agreement or its obligation to make further advances as a result of default under this Building Loan Agreement, it may enter into possession of the premises and perform any and all work and labor necessary to complete the Improvements substantially according to the Drawings and Specifications (with such changes as may be approved in writing by HUD), and employ watchmen to protect the premises from injury. All sums so expended by Lender shall be deemed to have been paid to Borrower and secured by the Security Instrument. For this purpose, Borrower hereby constitutes and appoints Lender its true and lawful attorney-in-fact, with full power of substitution in the premises, to complete the Project in the name of Borrower. Borrower hereby empowers said attorney as follows: (a) to use any funds of Borrower, including any balance that may be held in escrow and any funds that may remain unadvanced hereunder for the purpose of completing the Project in the manner called for by the Drawings and Specifications (with such changes as may be approved in writing by HUD); (b) to make such additions, changes and corrections in the Drawings and Specifications (with written HUD approval) as shall be necessary or desirable to complete the Project in substantially the manner contemplated by the Drawings and Specifications; (c) to employ such contractors, subcontractors, agents, architects and inspectors as shall be required for said purposes; (d) to pay, settle or compromise all existing bills and claims that may be liens against the Mortgaged Property, or as may be necessary or desirable for the completion of the Project, or for clearance of title; (e) to execute all applications and certificates in the name of Borrower that may be required by any of the contract documents; (f) to prosecute and defend all actions or proceedings in connection with the Mortgaged Property or the construction of the Project and to take such action and require such performance as it deems necessary under the accepted guaranty of completion; and (g) to do any and every act that Borrower might do in its own behalf. It is further understood and agreed that this power of attorney, which shall be deemed to be a power coupled with an interest, cannot be revoked. Borrower hereby assigns and quitclaims to Lender all sums unadvanced under the Security

Instrument and all sums held by Lender in escrow conditioned upon the use of said sums for the completion of the Project, such assignment to become effective only in case of a default by Borrower.

(10) Borrower shall provide or cause to be provided workers compensation insurance and public liability and other insurance required by applicable law, by the general conditions included in the Drawings and Specifications or by the Security Instrument. Borrower further agrees to purchase and maintain fire insurance and extended coverage on the Mortgaged Property. All such policies shall be issued by companies approved by Lender and shall be in form and amounts satisfactory to Lender and HUD. Such policies shall be endorsed with standard Lender clauses making loss payable to Lender, its successors and assigns; and may be endorsed to make loss during construction payable to the Contractor, as its interest appears. Lender shall have the right to hold the original policies or duplicate original policies.

(11) Lender and its agents and HUD and its agents shall, at all times during construction, have the right of entry and free access to the Project and the right to inspect all work done, and materials, equipment, building components and fixtures furnished, installed or stored either on or off the Land, and to inspect all books, subcontracts and records of Borrower. Lender and HUD have no obligation to make any such inspections. Any and all such inspections by the Lender or its agents shall solely be for the benefit of Lender and HUD. Any and all inspections by HUD or its agents shall solely be for the benefit of HUD. Neither Borrower nor any third party shall have any claims against the Lender, HUD or their respective agents as a result of such inspections. Neither HUD, nor the Lender, nor any of their respective agents assumes any obligation of the Borrower or any other person or entity with respect to the quality of construction of the Project, compliance of said construction with the Drawings and Specifications or any defects in said construction.

(12) Borrower shall execute and deliver to Lender a security agreement and financing statements, or other similar instrument, covering the UCC Collateral.

(13) Borrower shall furnish to Lender assurance of completion of the Project in the form specified by HUD. Such assurance of completion shall run to Lender as obligee and shall contain a provision granting to Lender the authority to assign all rights thereunder to HUD.

(14) (a) Borrower understands that the wages to be paid laborers and mechanics employed in the construction of the Project are required by the provisions of Section 212(a) of the National Housing Act, as amended, to be not less than the wages prevailing in the locality in which the work shall be performed for corresponding classes of laborers and mechanics employed on construction of a similar character, as determined by the Secretary of Labor pursuant to the Davis-Bacon Act and as published in the applicable prevailing wage determination. Borrower hereby states that it has read the determination by the Secretary of Labor and is fully familiar with the same.

(b) Borrower shall, as a condition precedent to any advance hereunder, submit to Lender (i) with each application for advance prior to the final application, certifications, in form approved by HUD, that all laborers and mechanics employed in the construction of the Project whose work is covered by that or any previous application and who have been paid in whole or in part on account of said employment, have been paid at rates not less those contained in the applicable prevailing wage determination; and (ii) with the final application for advance, certifications in form satisfactory to HUD, that the Project has been fully constructed in accordance with the provisions of this Building Loan Agreement and that all laborers and mechanics employed in the construction of the Project have been paid not less than the said prevailing wage rates. The applicable prevailing wage determination shall be construed to include every amendment to or modification of the determination that may be published prior to the beginning of construction or day the Note is initially endorsed for insurance, whichever occurs first; provided, that if construction has not begun within ninety (90) days after initial endorsement of the Note, the applicable prevailing wage determination shall include any modification of the determination that may be published prior to the beginning of construction.

(c) Borrower agrees that should any advances hereunder be ineligible for insurance under the National Housing Act, as amended, by reason of (i) the nonpayment of the said prevailing wage rates, or (ii) violation of any of the applicable labor standards provisions of the regulations of the Secretary of Labor ("Labor Standards"), Lender may withhold from Borrower all payments or advances payable to Borrower hereunder until Borrower establishes to the satisfaction of HUD that all laborers and mechanics or other persons employed in the construction of the Project have been paid said prevailing wage rates and that such violation of the Labor Standards provisions no longer exists. The written statement of any authorized agent of HUD declining to insure any advance of funds hereunder by reason of such nonpayment or violation shall be deemed conclusive proof that such advances are ineligible for mortgage insurance.

(d) In accordance with Article 1 of the Supplementary Conditions of the Contract for Construction, Borrower shall insert the labor standards provisions thereof in any contract made for the construction of the Project, or any part thereof, and shall require the Contractor to insert similar provisions in each subcontract relating to the construction of the Project.

(15) Lender and Borrower agree that the Loan shall be reduced by any amount required by the Agreement and Certification (HUD-93305M) between the parties hereto and HUD, which Agreement and Certification is incorporated herein by reference to the same extent as if set forth herein at length.

(16) Borrower shall furnish such records, papers and documents relating to the Project as Lender or HUD may reasonably require from time to time.

(17) Borrower shall not transfer, assign or pledge any right or interest in, or title to, any funds deposited by Borrower with Lender, or reserved by Lender for Borrower, without the prior written approval of Lender and HUD.

(18) As used in this instrument, the term “**Lender**” means the entity identified as “Lender” in the first paragraph of the Security Instrument, or any subsequent holder of the Note, and whenever the term “Lender” is used herein, the same shall be deemed to include the Obligee, or the Trustee(s) and the Beneficiary of the Security Instrument and shall also be deemed to be the mortgagee as defined by Program Obligations. This Building Loan Agreement shall be binding upon the parties hereto and their respective successors and assigns.

(19) HUD is not a party to this Building Loan Agreement and has no obligation to Borrower or Lender pursuant to this Building Loan Agreement. HUD, pursuant to the Contract of Insurance, has reserved the right to approve or disapprove certain actions in this Building Loan Agreement to protect the mortgage insurance fund.

(20) To the extent not inconsistent with applicable State law, Borrower’s liability under the Building Loan Agreement shall be limited to the same extent as set forth in the Note.

(21) No waiver by the Lender of any default under this Building Loan Agreement will be effective unless such waiver is in writing and signed by the Lender and HUD. No waiver by the Lender of any default under this Building Loan Agreement will operate as a waiver of any other default or of the same default on a future occasion. The Lender may delay in exercising or omit to exercise any right or remedy available under this Building Loan Agreement or any other loan document or by law or equity provided without waiving that or any past, present or future remedy. All rights and remedies of the Lender in this Building Loan Agreement and the other loan documents are cumulative, and none of these rights or remedies are exclusive of any other right or remedy allowed at law or in equity or in any other loan document, and all of these rights and remedies may be exercised and enforced concurrently.

(22) This Building Loan Agreement and the other loan documents represent the entire agreement between the Lender and the Borrower with respect to the subject matter of this Building Loan Agreement and supersede all previous agreements, negotiations, and understandings with respect to the subject matter of this Building Loan Agreement. Neither this Building Loan Agreement nor any of the other loan documents may be amended, altered or changed other than in writing signed by the Lender and the Borrower.

(23) Upon assignment by Lender of its interest under this Building Loan Agreement, Lender shall automatically be released from any and all obligations under this Building Loan Agreement that arise after the date of assignment and Borrower shall look solely to the assignee of this Building Loan Agreement for the enforcement of any of Borrower’s rights hereunder.

(24) BORROWER AND LENDER EACH (a) AGREE NOT TO ELECT A TRIAL BY JURY WITH RESPECT TO ANY ISSUE ARISING OUT OF THIS BUILDING LOAN

AGREEMENT OR THE RELATIONSHIP BETWEEN THE PARTIES AS LENDER AND BORROWER THAT IS TRIABLE OF RIGHT BY A JURY AND (b) WAIVES ANY RIGHT TO TRIAL BY JURY WITH RESPECT TO SUCH ISSUE TO THE EXTENT THAT ANY SUCH RIGHT EXISTS NOW OR IN THE FUTURE. THIS WAIVER OF RIGHT TO TRIAL BY JURY IS SEPARATELY GIVEN BY EACH PARTY, KNOWINGLY AND VOLUNTARILY WITH THE BENEFIT OF COMPETENT LEGAL COUNSEL.

Each signatory below hereby certifies that each of their statements and representations contained in this Building Loan Agreement and all their supporting documentation thereto are true, accurate, and complete. This Building Loan Agreement has been made, presented, and delivered for the purpose of influencing an official action of HUD in insuring the Loan, and may be relied upon by HUD as a true statement of the facts contained therein.

BORROWER**LENDER**

By:

By:

Print name and title

Print name and title

Attachments: Exhibit A
Exhibit B
Exhibit C

SECTION 011100
SUMMARY OF WORK

PART 1 - GENERAL

1.1 SUMMARY

- A. Section Includes:
1. Project information.
 2. Work covered by Contract Documents.
 3. Phased construction.
 4. Work performed by Owner.
 5. Owner-furnished/Contractor-installed (OFCI) products.
 6. Owner-furnished/Owner-installed (OFOI) products.
 7. Contractor-furnished/Owner-installed (CFOI) products.
 8. Contractor's use of site and premises.
 9. Coordination with occupants.
 10. Work restrictions.
 11. Specification and Drawing conventions.

1.2 PROJECT INFORMATION

- A. Project:
1. Baker Heights Redevelopment
 2. 1401 Poplar Street
 3. Everett, WA 98201
- B. Owner:
1. Everett Housing Legacy LLLP
 2. 3107 Colby Avenue
 3. Everett, WA 98201
- C. Architect:
1. GGLO
 2. 1301 First Avenue, Suite 301
 3. Seattle, WA 98101
- D. Architect's Consultants: Architect has retained design professionals who have prepared designated portions of Contract Documents. Refer to Document 000103 – Project Directory for contact information.
- E. Owner Consultants: Owner has retained the following design professionals who have prepared designated portions of Contract Documents:
1. Surveyor:
 - a. Pace Engineers, 11255 Kirkland Way, Kirkland, WA 98033.
 2. Geotechnical Engineer:
 - a. GeoEngineers, 17425 NE Union Hill Road, Suite 250, Redmond, WA 98052.
- F. Contractor: CDK Construction Services Inc has been engaged as Contractor for this Project.
- G. General Contractor/Construction Manager (GC/CM): Howard W. Treat, (425) 788-8441, HTreat@CDKConstructionServices.com.
1. General Contractor/Construction Manager (GC/CM) for this Project is Project's constructor. The terms "Construction Manager" and "Contractor" are synonymous.

- H. Digital Information Management System (DIMS): Project web-based digital information management software administered by Architect will be used for purposes of managing communication and documents during the construction stage.
 - 1. See Section 013100 – Project Management and Coordination for requirements for using Digital Information Management Software.

1.3 WORK COVERED BY CONTRACT DOCUMENTS

- A. Work of Project is defined by Contract Documents and consists of the following:
 - 1. Project includes the on-site and off-site work associated with construction of 105 units in four buildings. Building A is four story with elevators of Type VA with R-2, E and B uses. Buildings B, C and D are two- and three-stories, Type VB construction and R-2 use, plus other Work indicated in Contract Documents.
- B. Type of Contract:
 - 1. Project will be constructed under a single prime contract.

1.4 SUSTAINABLE PROJECT REQUIREMENTS

- A. Project is designed to meet Evergreen Sustainable Development Standard (ESDS) version 3.01 as indicated in the documents.

1.5 PHASED CONSTRUCTION

- A. Work shall be conducted in **<Insert number>** phases, with each phase substantially complete as indicated.
 - 1. Phase 1: Work of this phase consists of demolition of existing structures and site Work to prepare for subsequent phases. Phase 1 shall commence within **<Insert number of days>** after Notice to Proceed.
 - a. Substantial Completion: **insert date**.
 - 2. Phase 2: Work of this phase consists of construction of the work. Phase 2 shall commence within **<Insert number of days>** after Notice to Proceed and be ready for occupancy by Substantial Completion date indicated.
 - a. Substantial Completion: **insert date**.
- B. Before commencing Work of each phase, submit an updated copy of Contractor's construction schedule showing sequence, commencement, and completion dates[, **and move-out and -in dates of Owner's personnel**] for all phases of Work.

1.6 WORK PERFORMED BY OWNER

- A. General: Cooperate fully with Owner so work may be carried out smoothly, without interfering with or delaying Work under this Contract or work by Owner. Coordinate Work of this Contract with work performed by Owner.
- B. Preceding Work: Owner will perform the following construction operations at Project site. Those operations are scheduled to be substantially complete before Work under this Contract begins.
 - 1. Hazardous material abatement.
- C. Concurrent Work: Owner will perform the following construction operations at Project site. Those operations will be conducted simultaneously with Work under this Contract.
- D. Subsequent Work: Owner will perform the following additional work at site after Substantial Completion. Completion of that work will depend on successful completion of preparatory Work under this Contract.

1.7 WORK PERFORMED BY OWNER

- A. General: Cooperate fully with Owner so Owner's work may be carried out smoothly, without interfering with or delaying Work under this Contract or work by Owner. Coordinate with Owner to meet the following scheduling requirements:
1. Preceding Work: Work by Owner scheduled to be substantially complete before Work under this Contract begins.
 2. Concurrent Work: Work by Owner conducted simultaneously with Work under this Contract.
 3. Subsequent Work: Work by Owner will begin after Substantial Completion of Work under this Contract.

1.8 WORK UNDER OWNER'S SEPARATE CONTRACTS

- A. General: Cooperate fully with separate contractors so work on those contracts may be carried out smoothly, without interfering with or delaying Work under this Contract or other contracts. Coordinate Work of this Contract with work performed under separate contracts.
- B. Preceding Work: Owner **[has awarded]** **[will award]** separate contract(s) for the following construction operations at Project site. Those operations are scheduled to be substantially complete before Work under this Contract begins.
1. **<Insert name of Contract>**: To **<Insert name of separate Contractor>** **[to]** **[for]** **<Insert a brief description of work performed under separate contract>**.
- C. Concurrent Work: Owner **[has awarded]** **[will award]** **[and will assign to Contractor]** separate contract(s) for the following construction operations at Project site. Those operations will be conducted simultaneously with Work under this Contract.
1. **<Insert name of Contract>**: To **<Insert name of separate Contractor>** **[to]** **[for]** **<Insert a brief description of work performed under separate contract>**.
- D. Subsequent Work: Owner **[has awarded]** **[will award]** separate contract(s) for the following additional work to be performed at site following Substantial Completion. Completion of that work will depend on successful completion of preparatory Work under this Contract.
1. **<Insert name of Contract>**: To **<Insert name of separate Contractor>** **[to]** **[for]** **<Insert a brief description of work performed under separate contract>**.
- E. Future Work Not Part of this Contract: The Contract Documents include requirements that will allow Owner to carry out future work following completion of this Project; provide for the following future work:
1. **<Insert description of future work requiring consideration during construction of the Work of this Contract>**.

1.9 OWNER-FURNISHED, CONTRACTOR-INSTALLED (OFCI) PRODUCTS

- A. Owner will furnish products indicated. Work includes receiving, unloading, handling, storing, protecting, and installing Owner-furnished products **[and making building services connections]**.
- B. Owner's Responsibilities: Owner will furnish products indicated and perform the following, as applicable:
1. Provide to Contractor Owner-reviewed Product Data, Shop Drawings, and Samples.
 2. Provide for delivery of Owner-furnished products to Project site.
 3. Upon delivery, inspect, with Contractor present, delivered items.
 - a. If Owner-furnished products are damaged, defective, or missing, arrange for replacement.
 4. Obtain manufacturer's inspections, service, and warranties.
 5. Inform Contractor of earliest available delivery date for Owner-furnished products.

- C. Contractor's Responsibilities: The Work includes the following, as applicable:
 - 1. Designate delivery dates of Owner-furnished products in Contractor's construction schedule, utilizing Owner-furnished earliest available delivery dates.
 - 2. Review Owner-reviewed Product Data, Shop Drawings, and Samples, noting discrepancies and other issues in providing for Owner-furnished products in the Work.
 - 3. Receive, unload, handle, store, protect, and install Owner-furnished products.
 - 4. Make building services connections for Owner-furnished products.
 - 5. Protect Owner-furnished products from damage during storage, handling, and installation and prior to Substantial Completion.
 - 6. Repair or replace Owner-furnished products damaged following receipt.
 - D. Owner-Furnished/Contractor-Installed (OFCI) Products:
 - 1. **<Insert description, in separate subparagraphs, for each Owner-furnished product>.**
- 1.10 OWNER-FURNISHED/OWNER-INSTALLED (OFOI) PRODUCTS
- A. The Owner will furnish and install products indicated.
 - B. Owner-Furnished/Owner-Installed (OFOI) Products:
 - 1. **<Insert description, in separate subparagraphs, for each Owner-furnished/Owner-installed product>.**
- 1.11 CONTRACTOR-FURNISHED, OWNER-INSTALLED PRODUCTS (CFOI)
- A. Contractor shall furnish products indicated. Work includes unloading, handling, storing, and protecting Contractor-furnished products as directed and turning them over to Owner at Project closeout.
 - B. Contractor-Furnished, Owner-Installed Products:
 - 1. **<Insert description, in separate subparagraphs, for each Contractor-furnished, Owner-installed product>.**
- 1.12 CONTRACTOR'S USE OF SITE AND PREMISES
- A. Unrestricted Use of Site: Contractor shall have full use of Project site for construction operations during construction period. Contractor's use of Project site is limited only by Owner's right to perform work or to retain other contractors on portions of Project.
 - B. Restricted Use of Site: Contractor shall have limited use of Project site for construction operations as indicated on Drawings by Contract limits and as indicated by requirements of this Section.
 - C. Limits on Use of Site: Limit use of Project site to areas within Contract limits indicated. Do not disturb portions of Project site beyond areas in which Work is indicated.
 - 1. Limits on Use of Site: Confine construction operations to **<Insert description of areas where Work is permitted>.**
 - 2. Driveways, Walkways and Entrances: Keep driveways, loading areas, and entrances serving premises clear and available to Owner, Owner's employees, and emergency vehicles at all times. Do not use these areas for parking or for storage of materials.
 - a. Schedule deliveries to minimize use of driveways and entrances by construction operations.
 - b. Schedule deliveries to minimize space and time requirements for storage of materials and equipment on-site.
 - D. Condition of Existing Grounds: Maintain portions of existing grounds, landscaping, and hardscaping affected by construction operations throughout construction period. Repair damage caused by construction operations.

1.13 WORK RESTRICTIONS

- A. Comply with restrictions on construction operations.
 - 1. Comply with limitations on use of public streets and with other requirements of authorities having jurisdiction.
- B. On-Site Work Hours: Limit exterior Work to normal business working hours of 7:00 a.m. to 7:00 p.m., Monday through Saturday, unless otherwise indicated.
 - 1. Weekend Hours: No Work on Sunday.
 - 2. Interior Work: No time restrictions.
- C. On-Site Work Hours: Limit Work in existing building to normal business working hours of **<Insert time>** a.m. to **<Insert time>** p.m., Monday through Friday, unless otherwise indicated.
 - 1. Weekend Hours: **<Insert restrictions on times permitted for weekend work>**.
 - 2. Early Morning Hours: **<Insert restrictions or references to regulations by authorities having jurisdiction for restrictions on noisy work>**.
 - 3. Hours for Utility Shutdowns: **<Insert Owner's restrictions>**.
 - 4. Hours for **[Core Drilling]** **<Insert noisy activity>**: **<Insert Owner's restrictions>**.
- D. **[Existing Utility Interruptions: Do not interrupt utilities serving facilities occupied by Owner or others unless permitted under the following conditions and then only after providing temporary utility services according to requirements indicated:]**
 - 1. **[Notify Architect and Owner not less than 2 days in advance of proposed utility interruptions.]**
 - 2. **[Obtain Architect's and Owner's written permission before proceeding with utility interruptions.]**
- E. Noise, Vibration, and Odors: Coordinate operations that may result in high levels of noise and vibration, odors, or other disruption to Owner occupancy with Owner.
 - 1. Notify Architect and Owner not less than 2 days in advance of proposed disruptive operations.
 - 2. Obtain Architect's and Owner's written permission before proceeding with disruptive operations.
- F. Nonsmoking Building: Smoking is not permitted within building or within 25 feet of entrances, operable windows, or outdoor-air intakes.
- G. Smoking and Controlled Substance Restrictions: Use of tobacco products, alcoholic beverages, and other controlled substances on Project site is not permitted.
- H. Employee Identification: Provide identification tags for Contractor personnel working on Project site. Require personnel to use identification tags at all times.
- I. Employee Screening: Comply with Owner's requirements for drug and background screening of Contractor personnel working on Project site.
 - 1. Maintain list of approved screened personnel with Owner's representative.

1.14 SPECIFICATION AND DRAWING CONVENTIONS

- A. Specification Content: Specifications use certain conventions for style of language and intended meaning of certain terms, words, and phrases when used in particular situations. These conventions are as follows:
 - 1. Imperative mood and streamlined language are generally used in Specifications. The words "shall," "shall be," or "shall comply with," depending on context, are implied where a colon (:) is used within a sentence or phrase.
 - 2. Contractor shall perform Specification requirements unless specifically stated otherwise.
- B. Division 01 General Requirements: Requirements of Sections in Division 01 apply to Work of all Sections in Specifications.

- C. Drawing Coordination: Requirements for materials and products identified on Drawings are described in detail in Specifications. One or more of the following are used on Drawings to identify materials and products:
1. Terminology: Materials and products are identified by typical generic terms used in individual Specifications Sections.
 2. Abbreviations: Materials and products are identified by abbreviations scheduled on Drawings.
 3. Keynoting: Materials and products are identified by reference keynotes referencing Specification Section numbers found in this Project Manual.

PART 2 - PRODUCTS (NOT USED)

PART 3 - EXECUTION (NOT USED)

END OF SECTION 011100

SECTION 012500
SUBSTITUTION PROCEDURES

PART 1 - GENERAL

1.1 SUMMARY

- A. Section Includes
1. Administrative and procedural requirements for substitutions.

1.2 DEFINITIONS

- A. Substitutions: Changes in products, materials, equipment, and methods of construction from those required by Contract Documents and proposed by Contractor.
1. Substitutions for Cause: Changes proposed by Contractor that are required due to changed Project conditions, such as unavailability of product, regulatory changes, or unavailability of required warranty terms.
 2. Substitutions for Convenience: Changes proposed by Contractor or Owner that are not required in order to meet other Project requirements but may offer advantage to Contractor or Owner.

1.3 ACTION SUBMITTALS

- A. Proposed Products List: Submit list of proposed products, including name of manufacturer, trade name, model number, and reference standards if necessary, for each product, to Architect within 15 days after execution of Agreement.
- B. Substitution Requests: Electronically submit 1 PDF copy of each request for consideration in compliance with Section 013100 – Project Management and Coordination. Identify product or fabrication or installation method to be replaced. Include Specification Section Number and Title and Drawing numbers and titles.
- C. Substitution Requests: Comply with Digital Information Management System requirements. Submit documentation identifying product or fabrication or installation method to be replaced. Include Specification Section number and title and Drawing numbers and titles.
1. Substitution Request Form: Use any of the following forms:
 - a. Form that is part of web-based
 - b. Document 006325 – Request for Substitution Form, included in these Specifications.
 - c. CSI Form 13.1A.
 - d. Form acceptable to Owner and Architect.
 2. Documentation: Show compliance with requirements for substitutions and the following, as applicable:
 - a. Statement indicating why specified product or fabrication or installation method cannot be provided, if applicable.
 - b. Coordination of information, including a list of changes or revisions needed to other parts of Work and to construction performed by Owner and separate contractors that will be necessary to accommodate proposed substitution.
 - c. Detailed comparison of significant qualities of proposed substitution with those of specified Work. Include annotated copy of applicable Specification Section. Significant qualities may include attributes such as performance, weight, size, durability, visual effect, **[sustainable design characteristics,]** warranties, and specific features and requirements indicated. Indicate deviations, if any, from specified Work.
 - d. Product Data, including drawings and descriptions of products and fabrication and installation procedures.

- e. Samples, where applicable or requested.
 - f. Certificates and qualification data, where applicable or requested.
 - g. List of similar installations for completed projects, with project names and addresses as well as names and addresses of architects and owners.
 - h. Material test reports from a qualified testing agency, indicating and interpreting test results for compliance with requirements indicated.
 - i. Research reports evidencing compliance with building code in effect for Project from ICC-ES.
 - j. Detailed comparison of Contractor's construction schedule using proposed substitution with products specified for Work, including effect on overall Contract Time. If specified product or method of construction cannot be provided within Contract Time, include letter from manufacturer, on manufacturer's letterhead, stating date of receipt of purchase order, lack of availability, or delays in delivery.
 - k. Cost information, including a proposal of change, if any, in Contract Sum.
 - l. Contractor's certification that proposed substitution complies with requirements in Contract Documents except as indicated in substitution request, is compatible with related materials, and is appropriate for applications indicated.
 - m. Contractor's waiver of rights to additional payment or time that may subsequently become necessary because of failure of proposed substitution to produce indicated results.
3. Architect's Action: If necessary, Architect will request additional information or documentation for evaluation within 7 days of receipt of a comparable product request. Architect will notify Contractor of approval or rejection of proposed comparable product request within 15 days of receipt of request, or 7 days of receipt of additional information or documentation, whichever is later.
- a. Form of Architect's Approval of Submittal: As specified in Section 013300 – Submittal Procedures.
4. Architect's Actions:
- a. General: Forms of Acceptance include Change Order, Construction Change Directive, and Architect's Supplemental Instructions for minor changes in Work.
 - b. Prior to Bid: If, in Architect's opinion, proposed product is acceptable, Architect will include approved substitutions in a written addendum that will be issued to bidders. Proposed products not included by addendum are not acceptable. Acceptance of a Substitution Request does not relieve requestor from meeting requirements, procedures, and warranties indicated in Contract Documents
 - c. After Contract Award: If necessary, Architect will request additional information or documentation for evaluation within 7 days of receipt of a request for substitution. Architect will notify Contractor of acceptance or rejection of proposed substitution within 15 days of receipt of request, or 7 days of receipt of additional information or documentation, whichever is later.
 - d. Use product specified if Architect does not issue a decision on use of a proposed substitution within time allocated.
- 1.4 QUALITY ASSURANCE
- A. Compatibility of Substitutions: Investigate and document compatibility of proposed substitution with related products and materials. Engage a qualified testing agency to perform compatibility tests recommended by manufacturers.
- 1.5 PROCEDURES
- A. Coordination: Revise or adjust affected Work as necessary to integrate Work of approved substitutions.

1.6 SUBSTITUTIONS

- A. Prebid Substitutions (Prior Approval):
1. Instructions to Bidders (AIA Document A701) specifies time restrictions for submitting requests for substitutions during bidding period to requirements specified in this Section.
 2. Submittal Time Limit: To be received by Architect not less than 7 days before Bid opening.
 3. Consideration: Substitution will only be considered if submitted by Bidders and each request includes information listed under "Conditions" paragraphs specified below.
- B. Substitutions for Cause: Submit requests for substitution immediately on discovery of need for change, but not later than **15 days** prior to time required for preparation and review of related submittals.
1. Conditions: Architect will consider Contractor's request for substitution when the following conditions are satisfied. If the following conditions are not satisfied, Architect will return requests without action, except to record noncompliance with these requirements:
 - a. Requested substitution is consistent with Contract Documents and will produce indicated results.
 - b. Requested substitution provides sustainable design characteristics that specified product provided for compliance with ESDS requirements.
 - c. Substitution request is fully documented and properly submitted.
 - d. Requested substitution will not adversely affect Contractor's construction schedule.
 - e. Requested substitution has received necessary approvals of authorities having jurisdiction.
 - f. Requested substitution is compatible with other portions of Work.
 - g. Requested substitution has been coordinated with other portions of Work.
 - h. Requested substitution provides specified warranty.
 - i. If requested substitution involves more than 1 contractor, requested substitution has been coordinated with other portions of Work, is uniform and consistent, is compatible with other products, and is acceptable to all contractors involved.
- C. Substitutions for Convenience: Not allowed unless otherwise indicated.
- D. Substitutions for Convenience: Architect will consider requests for substitution if received within **60 days after Notice to Proceed**. Requests received after that time may be considered or rejected at discretion of Architect.
1. Conditions: Architect will consider Contractor's request for substitution when the following conditions are satisfied. If the following conditions are not satisfied, Architect will return requests without action, except to record noncompliance with these requirements:
 - a. Requested substitution offers Owner a substantial advantage in cost, time, energy conservation, or other considerations, after deducting additional responsibilities Owner must assume. Owner's additional responsibilities may include compensation to Architect for redesign and evaluation services, increased cost of other construction by Owner, and similar considerations.
 - b. Requested substitution does not require extensive revisions to Contract Documents.
 - c. Requested substitution is consistent with Contract Documents and will produce indicated results.
 - d. Requested substitution provides sustainable design characteristics that specified product provided for compliance with ESDS requirements.
 - e. Substitution request is fully documented and properly submitted.
 - f. Requested substitution will not adversely affect Contractor's construction schedule.
 - g. Requested substitution has received necessary approvals of authorities having jurisdiction.
 - h. Requested substitution is compatible with other portions of Work.
 - i. Requested substitution has been coordinated with other portions of Work.
 - j. Requested substitution provides specified warranty.

- k. If requested substitution involves more than 1 contractor, requested substitution has been coordinated with other portions of 1 Work, is uniform and consistent, is compatible with other products, and is acceptable to all contractors involved.
- l. When so directed by Architect, provide testing of equipment, material, or products being considered for substitution to assure compliance with Specifications, at no additional cost to Owner. If testing confirms equipment, material, or products meet requirements of specified equipment, material, or products, submit Samples to Architect for approval.
- 2. The following reasons are grounds for rejection of substitution requests. Equipment, material, and products installed or used without prior written approval from Architect shall be at risk of subsequent rejection.
 - a. Failure to complete required substitution request form or to submit requested information in acceptable format.
 - b. Where "No Substitutions" is noted or implied within individual Sections.
 - c. When substitutions are indicated or implied on Shop Drawings or Product Data submittals, without prior written approval from Architect.

PART 2 - PRODUCTS (NOT USED)

PART 3 - EXECUTION (NOT USED)

END OF SECTION 012500

SECTION 012600
CONTRACT MODIFICATION PROCEDURES

PART 1 - GENERAL

1.1 SUMMARY

A. Section Includes:

1. Administrative and procedural requirements for handling and processing Contract modifications.

1.2 MINOR CHANGES IN THE WORK

- A. Architect will issue supplemental instructions authorizing minor changes in Work, not involving adjustment to Contract Sum or Contract Time, on AIA Document G710 or similar form, or through web-based Project management software.

1.3 PROPOSAL REQUESTS

- A. Owner-Initiated Proposal Requests: Architect will issue a detailed description of proposed changes in Work that may require adjustment to Contract Sum or Contract Time. If necessary, the description will include supplemental or revised Drawings and Specifications.

1. Work Change Proposal Requests issued by Architect are not instructions either to stop Work in progress or to execute the proposed change.
2. Within time specified in Proposal Request or 20 days, when not otherwise specified, after receipt of Proposal Request, submit a quotation estimating cost adjustments to Contract Sum and Contract Time necessary to execute the change.
 - a. Include a list of quantities of products required or eliminated and unit costs, with total amount of purchases and credits to be made. If requested, furnish survey data to substantiate quantities.
 - b. Indicate applicable taxes, delivery charges, equipment rental, and amounts of trade discounts.
 - c. Include costs of labor and supervision directly attributable to the change.
 - d. Include an updated Contractor's construction schedule that indicates effect of change, including changes in activity duration, start and finish times, and activity relationship. Use available total float before requesting an extension of Contract Time.
 - e. Quotation Form: Use forms acceptable to Architect and Owner.

- B. Contractor-Initiated Proposals: If latent or changed conditions require modifications to Contract, Contractor may initiate a claim by submitting a request for a change to Architect.

1. Include a statement outlining reasons for change and effect of change on Work. Provide a complete description of proposed change. Indicate effect of proposed change on Contract Sum and Contract Time.
2. Include a list of quantities of products required or eliminated and unit costs, with total amount of purchases and credits to be made. If requested, furnish survey data to substantiate quantities.
3. Indicate applicable taxes, delivery charges, equipment rental, and amounts of trade discounts.
4. Include costs of labor and supervision directly attributable to change.
5. Include an updated Contractor's construction schedule that indicates effect of change, including changes in activity duration, start and finish times, and activity relationship. Use available total float before requesting an extension of Contract Time.
6. Comply with requirements in Section 012500 – Substitution Procedures if proposed change requires substitution of one product or system for product or system specified.
7. Proposal Request Form: Use form acceptable to Architect and Owner.

1.4 [ADMINISTRATIVE CHANGE ORDERS]

- A. **[Allowance Adjustment: See Section 012100 – Allowances for administrative procedures for preparation of Change Order Proposal for adjusting Contract Sum to reflect actual costs of allowances.]**
- B. **[Unit-Price Adjustment: See Section 012200 – Unit Prices for administrative procedures for preparation of Change Order Proposal for adjusting Contract Sum to reflect measured scope of unit-price Work.]**

1.5 CHANGE ORDER PROCEDURES

- A. On Owner's approval of a Work Change Proposal Request, Architect will issue a Change Order for signatures of Owner and Contractor on AIA Document G701 or similar form, or through web-based Project management software.

1.6 CONSTRUCTION CHANGE DIRECTIVE

- A. Construction Change Directive: Architect may issue a Construction Change Directive on AIA Document G714. Construction Change Directive instructs Contractor to proceed with a change in Work, for subsequent inclusion in a Change Order.
 - 1. Construction Change Directive contains a complete description of change in Work. It also designates method to be followed to determine change in Contract Sum or Contract Time.
- B. Documentation: Maintain detailed records on a time and material basis of Work required by Construction Change Directive.
 - 1. After completion of change, submit an itemized account and supporting data necessary to substantiate cost and time adjustments to Contract.

PART 2 - PRODUCTS (NOT USED)

PART 3 - EXECUTION (NOT USED)

END OF SECTION 012600

SECTION 012900
PAYMENT PROCEDURES

PART 1 - GENERAL

1.1 SUMMARY

A. Section Includes:

1. Administrative and procedural requirements necessary to prepare and process Applications for Payment.

1.2 DEFINITIONS

- A. Schedule of Values: A statement furnished by Contractor allocating portions of Contract Sum to various portions of Work and used as the basis for reviewing Contractor's Applications for Payment.

1.3 SCHEDULE OF VALUES

A. Coordination: Coordinate preparation of schedule of values with preparation of Contractor's construction schedule.

1. Coordinate line items in schedule of values with items required to be indicated as separate activities in Contractor's construction schedule.
2. Submit schedule of values to Architect and Owner at earliest possible date, but no later than 14 days after Notice to Proceed and prior to date scheduled for submittal of initial Applications for Payment.
3. **[Subschedules for Phased Work: Where Work is separated into phases requiring separately phased payments, provide subschedules showing values coordinated with each phase of payment.**
4.]Subschedules for Separate Elements of Work: Where Contractor's construction schedule defines separate elements of Work, provide subschedules showing values coordinated with each element.

B. Format and Content: Use Project Manual table of contents as a guide to establish line items for schedule of values. Provide at least one line item for each Specification Section.

1. Identification: Include the following Project identification on schedule of values:
 - a. Project name and location.
 - b. Owner's name.
 - c. Owner's Project number.
 - d. Name of Architect.
 - e. Architect's Project number.
 - f. Contractor's name and address.
 - g. Date of submittal.
2. Arrange schedule of values consistent with format of AIA Document G703.
3. Provide a breakdown of Contract Sum in enough detail to facilitate continued evaluation of Applications for Payment and progress reports. Provide multiple line items for principal subcontract amounts in excess of 1 percent of Contract Sum.
4. Provide a separate line item in schedule of values for each part of Work where Applications for Payment may include materials or equipment purchased or fabricated and stored, but not yet installed.
 - a. Differentiate between items stored on-site and items stored off-site.
5. Overhead Costs: Include total cost and proportionate share of general overhead and profit for each line item.
6. Temporary Facilities: Show cost of temporary facilities and other major cost items that are not direct cost of actual Work-in-place as separate line items.

7. Closeout Costs. Include separate line items under Contractor and principal subcontracts for Project closeout requirements in an amount totaling 5 percent of Contract Sum and subcontract amount.
8. Schedule of Values Revisions: Revise schedule of values when Change Orders or Construction Change Directives result in a change in Contract Sum. Include at least 1 separate line item for each Change Order and Construction Change Directive.

1.4 APPLICATIONS FOR PAYMENT

- A. Each Application for Payment following initial Application for Payment shall be consistent with previous applications and payments as certified by Architect and paid for by Owner.
- B. Payment Application Times: Submit Application for Payment to Architect by the 25th of the month unless indicated otherwise in Agreement between Owner and Contractor. The period covered by each Application for Payment is one month, ending on the last day of the month.
 1. Submit draft copy of Application for Payment 7 days prior to due date for review by Architect.
- C. Application for Payment Forms: Use AIA Document G702 and AIA Document G703 as form for Applications for Payment.
 1. Other Application for Payment forms proposed by Contractor shall be acceptable to Architect and Owner. Submit forms for approval with initial submittal of schedule of values.
- D. Application Preparation: Complete every entry on form. Notarize and execute by a person authorized to sign legal documents on behalf of Contractor. Architect will return incomplete applications without action.
 1. Entries shall match data on schedule of values and Contractor's construction schedule. Use updated schedules if revisions were made.
 2. Include amounts for Work completed following previous Application for Payment, whether or not payment has been received. Include only amounts for Work completed at time of Application for Payment.
 3. Include amounts of Change Orders and Construction Change Directives issued before last day of construction period covered by application.
 4. Indicate separate amounts for Work being carried out under Owner-requested Project acceleration.
- E. Stored Materials: Include in Application for Payment amounts applied for materials or equipment purchased or fabricated and stored, but not yet installed. Differentiate between items stored on-site and items stored off-site.
 1. Provide certificate of insurance, evidence of transfer of title to Owner, and consent of surety to payment for stored materials.
 2. Provide supporting documentation that verifies amount requested, such as paid invoices. Match amount requested with amounts indicated on documentation; do not include overhead and profit on stored materials.
 3. Provide summary documentation for stored materials indicating the following:
 - a. Value of materials previously stored and remaining stored as of date of previous Applications for Payment.
 - b. Value of previously stored materials put in place after date of previous Application for Payment and on or before date of current Application for Payment.
 - c. Value of materials stored since date of previous Application for Payment and remaining stored as of date of current Application for Payment.
- F. Transmittal: Submit signed and notarized original copy of each Application for Payment to Architect digital information management system as specified in Section 013100, ensuring receipt within 24 hours. Include waivers of lien and similar attachments if required.

- G. Waivers of Mechanic's Lien: With each Application for Payment, submit waivers of mechanic's lien from entities lawfully entitled to file a mechanic's lien arising out of Contract and related to Work covered by payment.
1. Submit partial waivers on each item for amount requested in previous application, after deduction for retainage, on each item.
 2. When an application shows completion of an item, submit conditional final or full waivers.
 3. Owner reserves the right to designate which entities involved in Work must submit waivers.
 4. Submit final Application for Payment with or preceded by conditional final waivers from every entity involved with performance of Work covered by application who is lawfully entitled to a lien.
 5. Waiver Forms: Submit executed waivers of lien on forms acceptable to Owner.
- H. Initial Application for Payment: Administrative actions and submittals that must precede or coincide with submittal of first Application for Payment include the following:
1. List of Subcontractors.
 2. Schedule of values.
 3. Contractor's construction schedule (preliminary if not final).
 4. Products list (preliminary if not final).
 5. **[Sustainable design action plans, including preliminary Project materials cost data.**
 6. **][Schedule of unit prices.**
 7.]Submittal schedule (preliminary if not final).
 8. List of Contractor's staff assignments.
 9. List of Contractor's principal consultants.
 10. Copies of building permits.
 11. Copies of authorizations and licenses from authorities having jurisdiction for performance of Work.
 12. Initial progress report.
 13. Report of preconstruction conference.
- I. Application for Payment at Substantial Completion: After Architect issues Certificate of Substantial Completion, submit an Application for Payment showing 100 percent completion for portions of Work claimed as substantially complete.
1. Include documentation supporting claim that Work is substantially complete and a statement showing an accounting of changes to Contract Sum.
 - a. Complete administrative actions, submittals, and Work preceding this application, as described in Section 017700 – Closeout Procedures.
 2. Indicate in application Certificate(s) of Substantial Completion issued previously for Owner occupancy of designated portions of Work.
- J. Final Payment Application: After completing Project closeout requirements, submit final Application for Payment with releases and supporting documentation not previously submitted and accepted, including the following:
1. Evidence of completion of Project closeout requirements.
 2. Certification of completion of final punch list items.
 3. Insurance certificates for products and completed operations where required and proof that taxes, fees, and similar obligations were paid.
 4. Updated final statement, accounting for final changes to Contract Sum.
 5. AIA Document G706.
 6. AIA Document G706A.
 7. AIA Document G707.
 8. Evidence that claims have been settled.
 9. Final meter readings for utilities, a measured record of stored fuel, and similar data as of date of Substantial Completion or when Owner took possession of and assumed responsibility for corresponding elements of Work.
 10. **[Final liquidated damages settlement statement.**
 11.]Proof that taxes, fees, and similar obligations are paid.

12. Waivers and releases.

PART 2 - PRODUCTS (NOT USED)

PART 3 - EXECUTION (NOT USED)

END OF SECTION 012900

SECTION 013100
PROJECT MANAGEMENT AND COORDINATION

PART 1 - GENERAL

1.1 SUMMARY

A. Section Includes:

1. Administrative provisions for coordinating construction operations on Project including the following:
 - a. Informational submittals.
 - b. General coordination procedures.
 - c. Request for Interpretation (RFI).
 - d. Digital Project management procedures.
 - e. Architect's Digital Data Files.
 - f. Project meetings.

1.2 DEFINITIONS

- A. BIM: Building Information Modeling.
- B. RFI: Request for Interpretation. Request from Owner, Architect, or Contractor seeking information required by or clarifications of Contract Documents.
- C. Digital Information Management System (DIMS): Architect's web-based digital information management software implemented for purposes of facilitating communications and managing documentation until Final Completion of Project.

1.3 INFORMATIONAL SUBMITTALS

- A. Subcontract List: Prepare a written summary identifying individuals or firms proposed for each portion of Work, including those who are to furnish products or equipment fabricated to a special design. Include the following information in tabular form:
 1. Name, address, telephone number, and email address of entity performing subcontract or supplying products.
 2. Number and title of related Specification Sections covered by subcontract.
 3. Drawing number and detail references, as appropriate, covered by subcontract.
- B. Key Personnel Names: Within 15 days of starting construction operations, submit a list of key personnel assignments, including superintendent and other personnel in attendance at Project site. Identify individuals and their duties and responsibilities; list addresses, cellular telephone numbers, and e-mail addresses. Provide names, addresses, and telephone numbers of individuals assigned as alternates in the absence of individuals assigned to Project.
 1. Post copies of list in project meeting room, in temporary field office, in web-based Digital Information Management System directory, and in prominent location inbuilt facility. Keep list current at all times.

1.4 GENERAL COORDINATION PROCEDURES

- A. Coordination: Coordinate construction operations included in different Specification Sections to ensure efficient and orderly installation of each part of Work. Coordinate construction operations included in different Sections that depend on each other for proper installation, connection, and operation.

1. Schedule construction operations in sequence required to obtain best results where installation of one part of Work depends on installation of other components, before or after its own installation.
 2. Coordinate installation of different components to ensure maximum performance and accessibility for required maintenance, service, and repair.
 3. Make adequate provisions to accommodate items scheduled for later installation.
- B. Prepare memoranda for distribution to each party involved, outlining special procedures required for coordination. Include such items as required notices, reports, and list of attendees at meetings.
1. Prepare similar memoranda for Owner and separate contractors if coordination of their Work is required.
- C. Administrative Procedures: Coordinate scheduling and timing of required administrative procedures with other construction activities to avoid conflicts and to ensure orderly progress of Work. Such administrative activities include the following:
1. Preparation of Contractor's construction schedule.
 2. Preparation of schedule of values.
 3. Installation and removal of temporary facilities and controls.
 4. Delivery and processing of submittals.
 5. Progress meetings.
 6. Preinstallation meetings.
 7. Project closeout activities.
 8. Startup and adjustment of systems.

1.5 COORDINATION DRAWINGS

- A. Coordination Digital Data Files: Prepare coordination digital data files according to the following requirements:
1. File Preparation Format: Same digital data software program, version, and operating system as original Drawings.
 2. File Submittal Format: Submit or post coordination drawing files using PDF format
 3. Architect will furnish Contractor 1 set of digital data files of Drawings for use in preparing coordination digital data files.
 - a. Architect makes no representations as to the accuracy or completeness of digital data files as they relate to Drawings.

1.6 REQUEST FOR INTERPRETATION (RFI)

- A. General: Immediately on discovery of need for additional information, clarification, or interpretation of Contract Documents, prepare and submit an RFI in Document 006313 – Request for Interpretation Form.
1. Architect will return without response those RFIs submitted to Architect by other entities controlled by Contractor.
 2. Coordinate and submit RFIs in a prompt manner to avoid delays in Contractor's Work or Work of Subcontractors.
 3. Whenever possible, request clarifications at next appropriate Project progress meeting, with response entered into meeting minutes to avoid issuing a formal RFI.
- B. Content of RFI: Include detailed, legible description of item needing information or interpretation and the following:
1. Project name.
 2. Project number.
 3. Date.
 4. Name of Owner.
 5. Name of Contractor.
 6. Name of Architect.

7. RFI number, numbered sequentially.
 8. RFI subject.
 9. Specification Section number and title and related paragraphs, as appropriate.
 10. Drawing number and detail references, as appropriate.
 11. Field dimensions and conditions, as appropriate.
 12. Contractor's suggested resolution. If suggested resolution impacts Contract Time or Contract Sum, state impact in RFI.
 13. Contractor's signature.
 14. Attachments: Include sketches, descriptions, measurements, photos, Product Data, Shop Drawings, and other information necessary to fully describe items needing interpretation.
 - a. Include dimensions, thicknesses, structural grid references, and details of affected materials, assemblies, and attachments on attached sketches.
- C. Architect's Action: Architect will review each RFI, determine action required, and respond. Allow 7 working days for Architect's response for each RFI. RFIs received by Architect after 1:00 p.m. will be considered as received the following working day.
1. The following Contractor-generated RFIs will be returned without action:
 - a. Requests for approval of submittals.
 - b. Requests for approval of substitutions.
 - c. Requests for approval of Contractor's means and methods.
 - d. Requests for coordination information already indicated in Contract Documents.
 - e. Requests for adjustments in Contract Time or Contract Sum.
 - f. Requests for interpretation of Architect's actions on submittals.
 - g. Incomplete RFIs or inaccurately prepared RFIs.
 2. Architect's action may include a request for additional information, in which case Architect's time for response will date from time of receipt by Architect of additional information.
 3. Architect's action on RFIs that may result in a change to Contract Time or Contract Sum may be eligible for Contractor to submit Change Proposal according to Section 012600 – Contract Modification Procedures.
 - a. If Contractor believes RFI response warrants change in Contract Time or Contract Sum, notify Architect in writing within 10 days of receipt of RFI response.
- D. RFI Log: Prepare, maintain, and submit a tabular log of RFIs organized by RFI number. Submit log weekly. Software log with not less than the following:
1. Project name.
 2. Name and address of Owner.
 3. Name and address of Contractor.
 4. Name and address of Architect.
 5. RFI number including RFIs that were returned without action or withdrawn.
 6. RFI description.
 7. Date the RFI was submitted.
 8. Date Architect's response was received.
 9. Identification of related Minor Change in Work, Construction Change Directive, and Proposal Request, as appropriate.
- E. On receipt of Architect's action, update RFI log and immediately distribute RFI response to affected parties. Review response and notify Architect within 7 days if Contractor disagrees with response.
- 1.7 DIGITAL PROJECT MANAGEMENT PROCEDURES
- A. Web-Based Digital Information Management System, General: Architect uses a web-based Digital Information Management System for purposes of hosting and managing Project communication and documentation until Final Completion. Use of this System for transmitting Project documentation is mandatory unless another option is approved by Architect.
1. Digital Information Management System performs the following minimum functions:
 - a. Receives, logs, and stores Project Documents.

- b. Provides electronic stamping and signatures.
 - c. Notifies addressees via email.
 2. Web-Based Digital Information Management Service: Newforma Project Cloud.
 3. Digital Information Management System shall include the following:
 - a. Project directory.
 - b. Project correspondence.
 - c. Drawing and Specification document hosting, viewing, and updating.
 - d. Meeting minutes.
 - e. Contract modification forms and logs.
 - f. RFI forms and logs.
 - g. Submittal forms and logs.
 - h. Architect's Supplementary Instruction forms and logs.
 - i. Proposal request forms and logs.
 - j. Change Order forms and logs.
 - k. Reminder and tracking functions.
 - l. Task and issue management.
 - m. Photo documentation.
 - n. Schedule and calendar management.
 - o. Payment application forms.
 - p. Online document collaboration.
 - q. Archiving function.
 - B. Conditions for Use of Digital Information Management System:
 1. Use Digital Information Management System for Project communications and submittals containing electronic files.
 2. File Format: PDF unless indicated otherwise. Exceptions include digital data drawings and physical product Samples.
 3. Access: Valid email address, internet service, and PDF software are required of each entity.
 - a. PDF Software: Use PDF software with ability to review, markup, and apply electronic stamps.
 4. Contractor's failure to submit and retrieve through Digital Information Management System will not be considered in delay claims associated with lost or missing information.
 5. Architect assumes no responsibility for information lost or not received by Contractor's failure to submit through Digital Information Management System.
 - C. PDF Document Preparation: Prepare PDFs required to be submitted to Architect as follows:
 1. Assemble complete submittal package into a single indexed file incorporating submittal requirements of a single Specification Section and transmittal form with links enabling navigation to each item.
 2. Name file with submittal number or other unique identifier, including revision identifier.
 3. Certifications: Where digitally submitted certificates and certifications are required, provide a digital signature with digital certificate on where indicated.
 - D. Training: Arrange for and conduct 1 hour web-based training session for Architect or Architect's representative, Contractor, and other necessary entities in use of Digital Information Management System software.
- 1.8 ARCHITECT'S DIGITAL DATA FILES
 - A. General: Architect will furnish Contractor with 1 set of Architect's BIM model and CAD drawings indicated below for use in preparing Shop Drawings, Project record drawings, and other required digital drawings, in compliance with the following conditions:
 1. Digital Data Licensing Agreement has been executed.
 2. Digital data drawings are not considered Contract Documents as defined by General Conditions for the Contract for Construction.

3. Architect makes no representations as to accuracy or completeness of digital data drawing files as they relate to Contract Drawings.
 4. Verify with Digital Data Licensing Agreement for software version and list of digital data files available from Architect.
 5. Do not transfer or reuse Instruments of Service in electronic or machine-readable form without prior written consent of Architect.
 6. Architect will furnish following digital data files for each appropriate discipline:
 - a. Floor plans.
 - b. Reflected ceiling plans.
 - c. Civil plans.
- B. Agreement: Architect will grant Contractor, Contractor's key personnel, Subcontractors, and other entities as necessary, access to Architect's digital data files at initial preconstruction meeting.
1. Prior to being granted access by Architect, each entity shall execute Document 005433 – Digital Data Licensing Agreement, included in Project Manual, or AIA Document C106 Digital Data Licensing Agreement.

1.9 PROJECT MEETINGS

- A. General: Schedule and conduct [**Contractor will schedule and conduct**] [**Owner will schedule and conduct**] meetings at Project site unless otherwise indicated.
1. Attendees: Inform participants and others involved, and individuals whose presence is required, of date and time of each meeting. Notify Owner and Architect of scheduled meeting dates and times a minimum of 10 working days prior to meeting.
 2. Agenda: Prepare meeting agenda. Distribute agenda to invited attendees.
 3. Minutes: Entity responsible for conducting meeting shall record significant discussions and agreements achieved. Distribute meeting minutes to everyone concerned, including Owner and Architect, within 3 days of meeting.
- B. Preconstruction Meeting: Schedule and conduct [**Contractor will schedule and conduct**] [**Owner will schedule and conduct**] a preconstruction meeting before starting construction at a time convenient to Owner and Architect, but no later than 14 days after Notice of Award.
1. Attendees: Authorized representatives of Owner, Owner's Commissioning Authority, Architect, and their consultants; Contractor and its superintendent; major Subcontractors; suppliers; and other concerned parties. Participants at meeting shall be familiar with Project and authorized to conclude matters relating to Work.
 2. Agenda: Discuss items of significance that could affect progress, including the following:
 - a. Responsibilities and personnel assignments.
 - b. Tentative construction schedule.
 - c. **[Phasing.**
 - d.]Critical Work sequencing and long lead items.
 - e. Designation of key personnel and their duties.
 - f. Lines of communications.
 - g. Use of web-based Digital Information Management software.
 - h. Procedures for processing field decisions and Change Orders.
 - i. Procedures for RFIs.
 - j. Procedures for testing and inspecting.
 - k. Procedures for processing Applications for Payment.
 - l. Distribution of Contract Documents.
 - m. Submittal procedures.
 - n. **[Sustainable design requirements.**
 - o.]Preparation of Record Documents.
 - p. Use of the premises[
 - q. Work restrictions.
 - r. Working hours.

- s. Owner's occupancy requirements.
 - t. Responsibility for temporary facilities and controls.
 - u. Procedures for moisture and mold control.
 - v. Procedures for disruptions and shutdowns.
 - w. Construction waste management and recycling.
 - x. Parking availability.
 - y. Office, Work, and storage areas.
 - z. Equipment deliveries and priorities.
 - aa. First aid.
 - bb. Security.
 - cc. Progress cleaning.
3. Minutes: Entity responsible for conducting meeting shall record and distribute meeting minutes within 2 days after meeting. Distribute minutes to Owner, Architect, each party present, and to other entities affected decisions made at meeting.
- C. **[Sustainable Design Requirements]** Coordination Meeting: Owner will schedule and conduct a sustainable design coordination meeting before starting construction, at a time convenient to Owner Architect, and Contractor.
- 1. Attendees: Authorized representatives of Owner, Owner's Commissioning Authority, Architect, and their consultants; Contractor and its Superintendent **[and sustainable design coordinator;]** major Subcontractors; suppliers; and other concerned parties. Participants at meeting shall be familiar with Project and authorized to conclude matters relating to Work.
 - 2. Agenda: Discuss items of significance that could affect meeting sustainable design requirements, including the following:
 - a. Sustainable design Project checklist.
 - b. General requirements for sustainable design-related procurement and documentation.
 - c. Project closeout requirements and sustainable design certification procedures.
 - d. **[Role of sustainable design coordinator.**
 - e.]Construction waste management.
 - f. Construction operations and sustainable design requirements and restrictions.
 - 3. Minutes: Entity responsible for conducting meeting shall record and distribute meeting minutes within 2 days after meeting. Distribute minutes to Owner, Architect, each party present, and to other entities affected decisions made at meeting.
- D. Preinstallation Meetings: Schedule and conduct **[Contractor will schedule and conduct]** preinstallation meetings at Project site before each construction activity when required by other Sections and when required for coordination with other construction.
- 1. Attendees: Installer and representatives of manufacturers and fabricators involved in or affected by installation and its coordination or integration with other materials and installations that have preceded or will follow. Advise Architect, and Owner's Commissioning Authority of scheduled meeting dates.
 - 2. Agenda: Review progress of other construction activities and preparations for particular activity under consideration, including requirements for the following:
 - a. Contract Documents.
 - b. Options.
 - c. Related RFIs.
 - d. Related Change Orders.
 - e. Purchases.
 - f. Deliveries.
 - g. Submittals.
 - h. **[Sustainable design requirements.**
 - i.]Review of mockups.
 - j. Possible conflicts.
 - k. Compatibility requirements.
 - l. Time schedules.

- m. Weather limitations.
 - n. Manufacturer's written instructions.
 - o. Warranty requirements.
 - p. Compatibility of materials.
 - q. Acceptability of substrates.
 - r. Temporary facilities and controls.
 - s. Space and access limitations.
 - t. Regulations of authorities having jurisdiction.
 - u. Testing and inspecting requirements.
 - v. Installation procedures.
 - w. Coordination with other Work.
 - x. Required performance results.
 - y. Protection of adjacent Work.
 - z. Protection of construction and personnel.
- 3. Record significant meeting discussions, agreements, and disagreements, including required corrective measures and actions.
 - 4. Reporting: Distribute minutes of meeting to each party present and to other parties requiring information.
 - 5. Do not proceed with installation if meeting cannot be successfully concluded. Initiate whatever actions are necessary to resolve impediments to performance of Work and reconvene meeting at earliest feasible date.
- E. Project Closeout Meeting: Schedule and conduct [**Contractor will schedule and conduct**] Project closeout meeting at a time convenient to Owner and Architect, but no later than **90 days** prior to scheduled date of Substantial Completion.
- 1. Conduct meeting to review requirements and responsibilities related to Project closeout.
 - 2. Attendees: Authorized representatives of Owner, Owner's Commissioning Authority, Architect, and their consultants; Contractor and its Superintendent; major Subcontractors; suppliers; and other concerned parties. Participants at meeting shall be familiar with Project and authorized to conclude matters relating to Work.
 - 3. Agenda: Discuss items of significance that could affect or delay Project closeout, including:
 - a. Preparation of Record Documents.
 - b. Procedures required prior to inspection for Substantial Completion and for final inspection for acceptance.
 - c. Procedures for completing and archiving web-based Project software site data files.
 - d. Submittal of written warranties.
 - e. **[Requirements for completing sustainable design documentation.**
 - f.]Requirements for preparing operations and maintenance data.
 - g. Requirements for delivery of material samples, attic stock, and spare parts.
 - h. Requirements for demonstration and training.
 - i. Preparation of Contractor's punch list.
 - j. Procedures for processing Applications for Payment at Substantial Completion and for final payment.
 - k. Submittal procedures.
 - l. Owner's partial occupancy requirements.
 - m. Installation of Owner's furniture, fixtures, and equipment.
 - n. Responsibility for removing temporary facilities and controls.
 - 4. Minutes: Entity conducting meeting shall record and distribute meeting minutes.
- F. Progress Meetings: Schedule and conduct [**Contractor will schedule and conduct**] progress meetings at a maximum of weekly intervals.
- 1. Coordinate dates of meetings with preparation of payment requests.
 - 2. Attendees: Owner, Owner's Commissioning Authority, Architect, Contractor, superintendent, Subcontractors, suppliers, Installers, relevant consultants, and other entities concerned with current progress or involved in planning, coordination, or performance of future activities.

- Participants at meeting shall be familiar with Project and authorized to conclude matters relating to Work.
3. Agenda: Review and correct or approve minutes of previous progress meeting. Review other items of significance that could affect progress. Include topics for discussion as appropriate to status of Project.
 - a. Contractor's Construction Schedule: Review progress since last meeting. Determine whether each activity is on time, ahead of schedule, or behind schedule, in relation to Contractor's construction schedule. Determine how construction behind schedule will be expedited; secure commitments from parties involved to do so. Discuss whether schedule revisions are required to ensure that current and subsequent activities will be completed within Contract Time.
 - 1) Review schedule for next period.
 - b. Review present and future needs of each entity present, including the following:
 - 1) Interface requirements.
 - 2) Sequence of operations.
 - 3)]Status of submittals.
 - 4) [Status of sustainable design documentation.**
 - 5)]Deliveries.
 - 6) Off-site fabrication.
 - 7) Access.
 - 8) Site use.
 - 9) Temporary facilities and controls.
 - 10) Progress cleaning.
 - 11) Quality and Work standards.
 - 12) Status of correction of deficient items.
 - 13) Field observations.
 - 14) Status of RFIs.
 - 15) Status of Proposal Requests.
 - 16) Pending changes.
 - 17) Status of Change Orders.
 - 18) Pending claims and disputes.
 - 19) Documentation of information for payment requests.
 4. Minutes: Entity responsible for conducting meeting shall record and distribute meeting minutes to each party present and to parties requiring information.
 - a. Schedule Updating: Revise Contractor's construction schedule after each progress meeting where revisions to schedule have been made or recognized. Issue revised schedule concurrently with report of each meeting.

PART 2 - PRODUCTS (NOT USED)

PART 3 - EXECUTION (NOT USED)

END OF SECTION 013100

SECTION 013200
CONSTRUCTION PROGRESS DOCUMENTATION

PART 1 - GENERAL

1.1 SUMMARY

A. Section Includes:

1. Administrative and procedural requirements for documenting progress of construction during performance of Work, including the following:
 - a. Startup construction schedule.
 - b. Contractor's Construction Schedule.
 - c. Construction schedule updating reports.
 - d. Daily construction reports.
 - e. Material location reports.
 - f. Site condition reports.
 - g. Unusual event reports.

1.2 DEFINITIONS

- A. Activity: A discrete part of a project that can be identified for planning, scheduling, monitoring, and controlling the construction Project. Activities included in a construction schedule consume time and resources.
1. Critical Activity: An activity on the critical path that must start and finish on planned early start and finish times.
 2. Predecessor Activity: An activity that precedes another activity in network.
 3. Successor Activity: An activity that follows another activity in network.
- B. Cost Loading: Allocation of schedule of values for completing an activity as scheduled. The sum of costs for activities shall equal total Contract Sum.
- C. CPM: Critical path method, which is a method of planning and scheduling a construction project where activities are arranged based on activity relationships. Network calculations determine when activities can be performed and the critical path of Project.
- D. Critical Path: Longest connected chain of interdependent activities through the network schedule that establishes the minimum overall Project duration and contains no float.
- E. Event: Starting or ending point of an activity.
- F. Float: Measure of leeway in starting and completing an activity.
1. Float time is not for the exclusive use or benefit of either Owner or Contractor, but is a jointly owned, expiring Project resource available to both parties as needed to meet schedule milestones and Contract completion date.
 2. Free float is the amount of time an activity can be delayed without adversely affecting the early start of the successor activity.
 3. Total float is the measure of leeway in starting or completing an activity without adversely affecting the planned Project completion date.
- G. Resource Loading: Allocation of manpower and equipment necessary for completing an activity as scheduled.

1.3 INFORMATIONAL SUBMITTALS

- A. Format for Submittals: Submit required submittals in compliance with Section 013100 – Project Management and Coordination for Digital Information Management Systems.
 - 1. Working electronic copy of schedule file, where indicated.
- B. Startup Construction Schedule.
 - 1. schedule of values for cost-loaded activities.
- C. Startup Network Diagram: Of size required to display entire network for entire construction period. Show how logic ties for activities.
- D. Contractor's Construction Schedule: Initial schedule, of size required to display entire schedule for entire construction period.
 - 1. Submit a working digital copy of schedule, using software indicated, and labeled to comply with requirements for submittals.
- E. CPM Reports: Concurrent with CPM schedule, submit each of the following reports. Format for each activity in reports shall contain activity number, activity description, cost and resource loading, original duration, remaining duration, early start date, early finish date, late start date, late finish date, and total float in calendar days.
 - 1. Activity Report: List of activities sorted by activity number and then early start date, or actual start date if known.
 - 2. Logic Report: List of preceding and succeeding activities for each activity, sorted in ascending order by activity number and then by early start date, or actual start date if known.
 - 3. Total Float Report: List of activities sorted in ascending order of total float.
- F. Construction Schedule Updating Reports: Submit with Applications for Payment.
- G. Daily Construction Reports: Submit at weekly [**monthly**] intervals.
- H. Material Location Reports: Submit at weekly [**monthly**] intervals.
- I. Site Condition Reports: Submit at time of discovery of differing conditions.
- J. Unusual Event Reports: Submit at time of unusual event.

1.4 QUALITY ASSURANCE

- A. Prescheduling Meeting: Conduct meeting at Project site after Notice of Award to comply with requirements in Section 013100 – Project Management and Coordination. Review methods and procedures related to preliminary construction schedule and Contractor's Construction Schedule, including the following:
 - 1. Review software limitations and content and format for reports.
 - 2. Verify availability of qualified personnel needed to develop and update schedule.
 - 3. Review delivery dates for Owner-furnished products.
 - 4. Review schedule for work of Owner's separate contracts.
 - 5. Review submittal requirements and procedures.
 - 6. Review time required for review of submittals and resubmittals.
 - 7. Review requirements for tests and inspections by independent testing and inspecting agencies.
 - 8. Review time required for Project closeout and Owner startup procedures[, **including commissioning activities**].
 - 9. Review and finalize list of construction activities to be included in schedule.
 - 10. Review procedures for updating schedule.

1.5 CONTRACTOR'S CONSTRUCTION SCHEDULE, GENERAL

- A. Computer Scheduling Software: Prepare schedules using current version of a program that has been developed specifically to manage construction schedules.
 - 1. Use Scheduling component of Project website software specified in Section 013100 – Project Management and Coordination, for current Windows operating system.
- B. Scheduling Consultant: Contractor may engage a consultant to provide planning, evaluation, and reporting using CPM scheduling.
 - 1. In-House Option: Owner may waive requirement to retain a consultant if Contractor employs skilled personnel with experience in CPM scheduling and reporting techniques. Submit qualifications.
 - 2. Meetings: Scheduling consultant shall attend meetings related to Project progress, alleged delays, and time impact.
- C. Time Frame: Extend schedule from date established for Notice of Award to date of Substantial Completion.
 - 1. Contract completion date shall not be changed by submission of a schedule that shows an early completion date, unless specifically authorized by Change Order.
- D. Activities: Treat each floor or separate area as a separate numbered activity for each main element of Work. Comply with the following:
 - 1. Activity Duration: Define activities so no activity is longer than 15 days, unless specifically allowed by Architect.
 - 2. Procurement Activities: Include procurement process activities for the following long lead items and major items, requiring a cycle of more than 60 days, as separate activities in schedule. Procurement cycle activities include submittals, approvals, purchasing, fabrication, and delivery.
 - a. **<Insert list of major items or pieces of equipment>**.
 - 3. Submittal Review Time: Include review and resubmittal times indicated in Section 013300 – Submittal Procedures in schedule. Coordinate submittal review times in Contractor's Construction Schedule with submittal schedule.
 - 4. Startup and Testing Time: Include no fewer than 15 days for startup and testing.
 - 5. Commissioning Time: Include no fewer than 15 days for commissioning.
 - 6. Substantial Completion: Indicate completion in advance of date established for Substantial Completion, and allow time for Architect's administrative procedures necessary for certification of Substantial Completion.
 - 7. Punch List and Final Completion: Include not more than 30 days for completion of punch list items and final completion.
- E. Constraints: Include constraints and Work restrictions indicated in Contract Documents and as follows in schedule, and show how sequence of Work is affected.
 - 1. **[Phasing: Arrange list of activities on schedule by phase.**
 - 2. **][Work by Owner: Include a separate activity for each portion of work performed by Owner.**
 - 3.]Include delivery dates for Owner-furnished products and products ordered in advance. Delivery dates indicated stipulate earliest possible delivery dates.
 - 4. Products Ordered in Advance: Include a separate activity for each product.
 - 5. Owner-Furnished Products: Include a separate activity for each product.
 - 6. Work Restrictions: Show the effect of the following items on schedule:
 - a. **][Limitations of continued occupancies.**
 - b. **][Uninterruptible services.**
 - c.]Partial occupancy before Substantial Completion.
 - d. Use-of-premises restrictions.
 - e. Provisions for future construction.
 - f. Seasonal variations.

- g. Environmental control.
 - 7. Work Stages: Indicate important stages of construction for each major portion of Work, including the following:
 - a. Subcontract awards.
 - b. Submittals.
 - c. Purchases.
 - d. Mockups.
 - e. Fabrication.
 - f. Sample testing.
 - g. Deliveries.
 - h. Installation.
 - i. Tests and inspections.
 - j. Adjusting.
 - k. Curing.
 - l.]Startup and placement into final use and operation.
 - m. Commissioning.
- F. Milestones: Include milestones indicated in Contract Documents in schedule, including Notice to Proceed, Substantial Completion, and final completion, and the following interim milestones:
 - 1. Temporary enclosure and space conditioning.
- G. Cost Correlation: Superimpose a cost correlation timeline, indicating planned and actual costs. On the line, show planned and actual dollar volume of Work performed as of planned and actual dates used for preparation of payment requests.
 - 1. See Section 012900 – Payment Procedures for cost reporting and payment procedures.
- H. Upcoming Work Summary: Prepare summary report indicating activities scheduled to occur or commence prior to submittal of next schedule update. Summarize the following issues:
 - 1. Unresolved issues.
 - 2. Unanswered Requests for Information.
 - 3. Rejected or unreturned submittals.
 - 4. Notations on returned submittals.
 - 5. Pending modifications affecting Work and Contract Time.
- I. Contractor's Construction Schedule Updating: At weekly intervals, update schedule to reflect actual construction progress and activities. Issue schedule 1 week before each regularly scheduled progress meeting.
 - 1. Revise schedule immediately after each meeting or other activity where revisions have been recognized or made. Issue updated schedule concurrently with report of each such meeting.
 - 2. Include a report with updated schedule that indicates every change, including changes in logic, durations, actual starts and finishes, and activity durations.
 - 3. As Work progresses, indicate final completion percentage for each activity.
- J. Recovery Schedule: When periodic update indicates Work is 14 or more calendar days behind current approved schedule, submit a separate recovery schedule indicating means by which Contractor intends to regain compliance with schedule. Indicate changes to working hours, working days, crew sizes, equipment required to achieve compliance, and date by which recovery will be accomplished.
- K. Distribution: Distribute copies of approved schedule to Architect Owner, separate contractors, testing and inspecting agencies, and other parties identified by Contractor with a need-to-know schedule responsibility.
 - 1. Post copies in Project meeting rooms and temporary field offices.
 - 2. When revisions are made, distribute updated schedules to same parties and post in same locations. Delete parties from distribution when they have completed their assigned portion of Work and are no longer involved in performance of construction activities.

1.6 CPM SCHEDULE REQUIREMENTS

- A. General: Prepare network diagrams using AON (activity-on-node) format.
- B. Startup Network Diagram: Submit diagram within 14 days of date established for Notice of Award. Outline significant construction activities for the first 90 days of construction. Include skeleton diagram for remainder of Work and a cash requirement prediction based on indicated activities.
- C. CPM Schedule: Prepare Contractor's Construction Schedule using a time-scaled CPM network analysis diagram for Work.
 - 1. Develop network diagram in sufficient time to submit CPM schedule so it can be accepted for use no later than 60 days after date established for Notice to Proceed.
 - a. Failure to include any Work item required for performance of this Contract shall not excuse Contractor from completing Work within applicable completion dates.
 - 2. Conduct educational workshops to train and inform key Project personnel, including Subcontractors' personnel, in proper methods of providing data and using CPM schedule information.
 - 3. Establish procedures for monitoring and updating CPM schedule and for reporting progress. Coordinate procedures with progress meeting and payment request dates.
 - 4. Use "one workday" as unit of time for individual activities. Indicate nonworking days and holidays incorporated into schedule to coordinate with Contract Time.
- D. CPM Schedule Preparation: Prepare a list of activities required to complete Work. Using startup network diagram, prepare a skeleton network to identify probable critical paths.
 - 1. Activities: Indicate estimated time duration, sequence requirements, and relationship of each activity in relation to other activities. Include estimated time frames for the following activities:
 - a. Preparation and processing of submittals.
 - b. Mobilization and demobilization.
 - c. Purchase of materials.
 - d. Delivery.
 - e. Fabrication.
 - f. Utility interruptions.
 - g. Installation.
 - h. Work by Owner that may affect or be affected by Contractor's activities.
 - i. Testing and inspection.
 - j. Commissioning.
 - k. Punch list and final completion.
 - l. Activities occurring following final completion.
 - 2. Critical Path Activities: Identify critical path activities, including those for interim completion dates. Scheduled start and completion dates shall be consistent with Contract milestone dates.
 - 3. Processing: Process data to produce output data on a computer-drawn, time-scaled network. Revise data, reorganize activity sequences, and reproduce as often as necessary to produce CPM schedule within limitations of Contract Time.
 - 4. Format: Mark critical path. Locate critical path near center of network; locate paths with most float near edges.
 - a. Subnetworks on separate sheets are permissible for activities clearly off critical path.
 - 5. Cost- and Resource-Loading of CPM Schedule: Assign cost to construction activities on CPM schedule. Do not assign costs to submittal activities. Obtain Architect's approval prior to assigning costs to fabrication and delivery activities. Assign costs under main subcontracts for testing and commissioning activities, operation and maintenance manuals, punch list activities, Project record documents, **[sustainable design documentation]**, and demonstration and training (if applicable), in amount of 5 percent of Contract Sum.
 - a. Each activity cost shall reflect an appropriate value subject to approval by Architect.
 - b. Total cost assigned to activities shall equal total Contract Sum.

- E. Contract Modifications: For each proposed Contract modification and concurrent with its submission, prepare a time-impact analysis using a network fragment to demonstrate the effect of proposed change on overall Project schedule.
- F. Initial Issue of Schedule: Prepare initial network diagram from a sorted activity list indicating straight "early start-total float." Identify critical activities. Prepare tabulated reports showing the following:
 - 1. Contractor or Subcontractor and Work or activity.
 - 2. Description of activity.
 - 3. Main events of activity.
 - 4. Immediately preceding and succeeding activities.
 - 5. Early and late start dates.
 - 6. Early and late finish dates.
 - 7. Activity duration in workdays.
 - 8. Total float or slack time.
 - 9. Average size of workforce.
 - 10. Dollar value of activity (coordinated with schedule of values).
- G. Schedule Updating: Concurrent with making revisions to schedule, prepare tabulated reports showing the following:
 - 1. Identification of activities that have changed.
 - 2. Changes in early and late start dates.
 - 3. Changes in early and late finish dates.
 - 4. Changes in activity durations in workdays.
 - 5. Changes in critical path.
 - 6. Changes in total float or slack time.
 - 7. Changes in Contract Time.
- H. Value Summaries: Prepare 2 cumulative value lists, sorted by finish dates.
 - 1. In first list, tabulate activity number, early finish date, dollar value, and cumulative dollar value.
 - 2. In second list, tabulate activity number, late finish date, dollar value, and cumulative dollar value.
 - 3. In subsequent issues of both lists, substitute actual finish dates for activities completed as of list date.
 - 4. Prepare list for ease of comparison with payment requests; coordinate timing with progress meetings.
 - a. In both value summary lists, tabulate "actual percent complete" and "cumulative value completed" with total at bottom.
 - b. Submit value summary printouts 1 week before each regularly scheduled progress meeting.

1.7 REPORTS

- A. Daily Construction Reports: Prepare a daily construction report recording the following information concerning events at Project site:
 - 1. List of Subcontractors at Project site.
 - 2. Approximate count of personnel at Project site.
 - 3. Equipment at Project site.
 - 4. Material deliveries.
 - 5. High and low temperatures and general weather conditions, including presence of rain or snow.
 - 6. Testing and inspection.
 - 7. Accidents.
 - 8. Meetings and significant decisions.
 - 9. Unusual events.
 - 10. Stoppages, delays, shortages, and losses.
 - 11. Meter readings and similar recordings.

12. Emergency procedures.
 13. Orders and requests of authorities having jurisdiction.
 14. Change Orders received and implemented.
 15. Construction Change Directives received and implemented.
 16. Services connected and disconnected.
 17. Equipment or system tests and startups.
 18. Partial completions and occupancies.
 19. Substantial Completions authorized.
- B. Material Location Reports: At weekly intervals, prepare and submit a comprehensive list of materials delivered to and stored at Project site . List shall be cumulative, showing materials previously reported plus items recently delivered. Include with list a statement of progress on and delivery dates for materials or items of equipment fabricated or stored away from Project site. Indicate the following categories for stored materials:
1. Material stored prior to previous report and remaining in storage.
 2. Material stored prior to previous report and since removed from storage and installed.
 3. Material stored following previous report and remaining in storage.
- C. Site Condition Reports: Immediately on discovery of a difference between site conditions and Contract Documents, prepare and submit a detailed report. Submit with a Request for Information. Include a detailed description of differing conditions, together with recommendations for changing Contract Documents.
- D. Unusual Event Reports: When an event of an unusual and significant nature occurs at Project site, whether or not related directly to Work, prepare and submit a special report. List chain of events, persons participating, responses by Contractor's personnel, evaluation of results or effects, and similar pertinent information. Advise Owner in advance when these events are known or predictable.
1. Submit unusual event reports directly to Owner within 1 days of an occurrence. Distribute copies of report to parties affected by occurrence.

PART 2 - PRODUCTS (NOT USED)

PART 3 - EXECUTION (NOT USED)

END OF SECTION 013200

SECTION 013233
PHOTOGRAPHIC DOCUMENTATION

PART 1 - GENERAL

1.1 SUMMARY

- A. Section includes:
 - 1. Administrative and procedural requirements for the following:
 - a. Preconstruction photographs.
 - b. Concealed Work photographs.
 - c. Periodic construction photographs.
 - d. Final completion construction photographs.

1.2 INFORMATIONAL SUBMITTALS

- A. Key Plan: Submit key plan of Project site and building with notation of vantage points marked for location and direction of each photograph. Indicate elevation or story of construction. Include same information as corresponding photographic documentation.
- B. Digital Photographs: Submit image files within 3 days of taking photographs.
 - 1. Submit photos by uploading to web-based project software site. Include copy of key plan indicating each photograph's location and direction.
 - 2. Identification: Provide the following information with each image in web-based project software site:
 - a. Name of Project.
 - b. Name and contact information for photographer.
 - c. Name of Architect.
 - d. Name of Contractor.
 - e. Date photograph was taken.
 - f. Description of location, vantage point, and direction.
 - g. Unique sequential identifier keyed to accompanying key plan.

1.3 QUALITY ASSURANCE

- A. Photographer Qualifications: An individual who has been regularly engaged as a professional photographer of construction projects for not less than 3 years.

1.4 FORMATS AND MEDIA

- A. Digital Photographs: Provide color images in JPG format, produced by a digital camera with minimum sensor size of 12 megapixels, and at an image resolution of not less than 3200 by 2400 pixels, and with vibration-reduction technology. Use flash in low light levels or backlit conditions.
- B. Digital Images: Submit digital media as originally recorded in digital camera, without alteration, manipulation, editing, or modifications using image-editing software.
- C. Metadata: Record accurate date and time and GPS location data from camera.
- D. File Names: Name media files with date, Project area, and sequential numbering suffix.

1.5 CONSTRUCTION PHOTOGRAPHS

- A. Photographer: Engage a qualified photographer to take construction photographs.

- B. General: Take photographs with maximum depth of field and in focus.
 - 1. Maintain key plan with each set of construction photographs that identifies each photographic location.
- C. Preconstruction Photographs: Before commencement of Work, take photographs of Project site and surrounding properties, including existing items to remain during construction, from different vantage points, as directed by Architect.
 - 1. Flag construction limits before taking construction photographs.
 - 2. Take 20 photographs to show existing conditions adjacent to property before starting Work.
 - 3. Take 20 photographs of existing buildings either on or adjoining property to accurately record physical conditions at start of construction.
 - 4. Take additional photographs as required to record settlement or cracking of adjacent structures, pavements, and improvements.
- D. Concealed Work Photographs: Before proceeding with installing Work that will conceal other Work, take photographs sufficient in number, with annotated descriptions, to record nature and location of concealed Work, including the following:
 - 1. Underground utilities.
 - 2. Underslab services.
 - 3. Piping.
 - 4. Electrical conduit.
 - 5. Waterproofing and weather-resistant barriers.
- E. Periodic Construction Photographs: Take 20 photographs weekly coinciding with cutoff date associated with each Application for Payment. Select vantage points to show status of construction and progress since last photographs were taken.
- F. Final Completion Construction Photographs: Take 20 photographs after date of Substantial Completion for submission as Project Record Documents. Architect will inform photographer of desired vantage points.
- G. Additional Photographs: Architect may request photographs in addition to periodic photographs specified. Additional photographs will be paid for by Change Order and are not included in Contract Sum.
 - 1. 3 days' notice will be given, where feasible.
 - 2. In emergency situations, take additional photographs within 24 hours of request.
 - 3. Circumstances that could require additional photographs include the following:
 - a. Special events planned at Project site.
 - b. Immediate follow-up when on-site events result in construction damage or losses.
 - c. Photographs to be taken at fabrication locations away from Project site. These photographs are not subject to unit prices or unit-cost allowances.
 - d. Substantial Completion of a major phase or component of Work.
 - e. Extra record photographs at time of final acceptance.
 - f. Owner's request for special publicity photographs.

PART 2 - PRODUCTS (NOT USED)

PART 3 - EXECUTION (NOT USED)

END OF SECTION 013233

SECTION 013300
SUBMITTAL PROCEDURES

PART 1 - GENERAL

1.1 SUMMARY

- A. Section Includes:
 - 1. Submittal schedule requirements.
 - 2. Administrative and procedural requirements for submittals.

1.2 DEFINITIONS

- A. Action Submittals: Written and graphic information and physical Samples that require Architect's responsive action. Action submittals are those submittals indicated in individual Specification Sections as "action submittals."
- B. Digital Information Management System (DIMS): Defined in Section 013100 – Project Management and Coordination.
- C. Informational Submittals: Written and graphic information and physical Samples that do not require Architect's responsive action. Submittals may be rejected for not complying with requirements. Informational submittals are those submittals indicated in individual Specification Sections as "informational submittals."
- D. Portable Document Format (PDF): An open standard file format licensed by Adobe Systems used for representing documents in a device-independent and display resolution-independent fixed-layout document format.

1.3 SUBMITTAL SCHEDULE

- A. Prepare and submit each type of submittal required by individual Specification Sections.
 - 1. Comply with requirements of Section 013100 – Project Management and Coordination for submittals using Digital Information Management System.
 - 2. Prepare submittals in PDF format and upload to Digital Information Management System. Enter required data in Digital Information Management System to fully identify submittal.
 - a. Paper document transmittals and emailed PDF documents will not be reviewed.
 - 3. Architect will return annotated file. Annotate and retain 1 copy of file as an electronic Project record document file.
 - 4. [Commissioning Authority, through Architect, will return annotated file.]
- B. Coordination: Coordinate preparation and processing of submittals with performance of construction activities.
 - 1. Coordinate each submittal with fabrication, purchasing, testing, delivery, other submittals, and related activities that require sequential activity.
 - 2. Submit submittal items required for each Specification Section concurrently unless partial submittals for portions of Work are indicated on approved submittal schedule.
 - 3. Submit action submittals and informational submittals required by same Specification Section as separate packages under separate transmittals.
 - 4. Coordinate transmittal of submittals for related parts of Work specified in different Sections so processing will not be delayed because of need to review submittals concurrently for coordination.
 - a. Architect reserves the right to withhold action on a submittal requiring coordination with other submittals until related submittals are received.

- C. Processing Time: Allow time for submittal review, including time for resubmittals, as follows. Time for review shall commence on Architect's receipt of submittal. No extension of Contract Time will be authorized because of failure to transmit submittals enough in advance of Work to permit processing, including resubmittals.
1. Initial Review: Allow **15 days** for initial review of each submittal. Allow additional time if coordination with subsequent submittals is required. Architect will advise Contractor when a submittal being processed must be delayed for coordination.
 2. Intermediate Review: If intermediate submittal is necessary, process it in same manner as initial submittal.
 3. Resubmittal Review: Allow **15 days** for review of each resubmittal.
 4. Sequential Review: Where sequential review of submittals by Architect's consultants, Owner, or other parties is indicated, allow **21 days** for initial review of each submittal.
 - a. **<Insert list of Specification Sections requiring sequential review>**.
 5. Concurrent Consultant Review: Where Contract Documents indicate that submittals may be transmitted simultaneously to Architect and to Architect's consultants, allow **15 days** for review of each submittal. Submittal will be returned to Architect before being returned to Contractor.
 - a. Submit 1 copy of submittal to concurrent reviewer in addition to specified number of copies to Architect.
- D. Resubmittals: Make resubmittals in same form and number of copies as initial submittal.
1. Note date and content of previous submittal.
 2. Note date and content of revision in label or title block and clearly indicate extent of revision.
 3. Resubmit submittals until they are marked with approval notation from Architect's action stamp.
- E. Distribution: Furnish copies of final submittals to manufacturers, Subcontractors, suppliers, fabricators, installers, authorities having jurisdiction, and others as necessary for performance of construction activities. Show distribution on transmittal forms.
- F. Use for Construction: Retain complete copies of submittals on Project site. Use only final action submittals that are marked with approval notation from Architect's action stamp.

1.4 ACTION SUBMITTALS

- A. Submittal Schedule: Submit, as an action submittal, a list of submittals, arranged in chronological order by dates required by construction schedule. Include time required for review, ordering, manufacturing, fabrication, and delivery when establishing dates. Include additional time required for making corrections or revisions to submittals noted by Architect and additional time for handling and reviewing submittals required by those corrections.
1. Coordinate submittal schedule with list of subcontracts, schedule of values, and Contractor's construction schedule.
 2. Initial Submittal: Submit concurrently with startup construction schedule. Include submittals required during first 60 days of construction. List those submittals required to maintain orderly progress of Work and those required early because of long lead time for manufacture or fabrication.
 3. Final Submittal: Submit concurrently with first complete submittal of Contractor's construction schedule.
 - a. Submit revised submittal schedule to reflect changes in current status and timing for submittals.
 4. Format: Arrange the following information in a tabular format:
 - a. Scheduled date for first submittal.
 - b. Specification Section number and title.
 - c. Submittal Category: Action; informational.
 - d. Name of Subcontractor.
 - e. Description of Work covered.
 - f. Scheduled date for Architect's final release or approval.

- g. Scheduled dates for purchasing.
- h. Scheduled date of fabrication.
- i. Scheduled dates for installation.
- j. Activity or event number.

1.5 SUBMITTAL FORMATS

- A. No paper submittals will be transported unless a physical sample is required. All such submittals shall be electronic format as described herein.
- B. Submittal Information: Include the following information in each submittal:
 - 1. Project name.
 - 2. Date.
 - 3. Name of Architect.
 - 4. Name of Contractor.
 - 5. Name of firm or entity that prepared submittal.
 - 6. Names of Subcontractor, manufacturer, and supplier.
 - 7. Unique submittal number, including revision identifier. Include Specification Section number with sequential alphanumeric identifier; and alphanumeric suffix for resubmittals.
 - 8. Category and type of submittal.
 - 9. Submittal purpose and description.
 - 10. Number and title of Specification Section, with paragraph number and generic name for each of multiple items.
 - 11. Drawing number and detail references, as appropriate.
 - 12. Indication of full or partial submittal.
 - 13. Location(s) where product is to be installed, as appropriate.
 - 14. Other necessary identification.
 - 15. Remarks.
 - 16. Signature of transmitter.
- C. Options: Identify options requiring selection by Architect.
- D. Deviations and Additional Information: On each submittal, clearly indicate deviations from requirements in Contract Documents, including minor variations and limitations; include relevant additional information and revisions, other than those requested by Architect on previous submittals. Indicate by highlighting on each submittal or noting on attached separate sheet.
- E. Submittals for Digital Information Management System: Prepare PDF submittals as indicated in Section 013100.

1.6 SUBMITTAL REQUIREMENTS

- A. Product Data: Collect information into a single submittal for each element of construction and type of product or equipment.
 - 1. If information must be specially prepared for submittal because standard published data are unsuitable for use, submit as Shop Drawings, not as Product Data.
 - 2. Mark each copy of each submittal to show which products and options are applicable.
 - 3. Include the following information, as applicable:
 - a. Manufacturer's catalog cuts.
 - b. Manufacturer's product specifications.
 - c. Manufacturer's written recommendations.
 - d. Manufacturer's installation instructions.
 - e. Standard color charts.
 - f. Statement of compliance with specified referenced standards.
 - g. Testing by recognized testing agency.
 - h. Application of testing agency labels and seals.

- i. Notation of coordination requirements.
 - j. Availability and delivery time information.
 4. For equipment, include the following in addition to the above, as applicable:
 - a. Wiring diagrams that show factory-installed wiring.
 - b. Printed performance curves.
 - c. Operational range diagrams.
 - d. Clearances required to other construction, if not indicated on accompanying Shop Drawings.
 5. Submit Product Data before Shop Drawings, and before or concurrent with Samples.
 - B. Shop Drawings: Prepare Project-specific information, drawn accurately to scale. Do not base Shop Drawings on reproductions of Contract Documents or standard printed data[**unless submittal based on Architect's digital data drawing files is otherwise permitted**].
 1. Preparation: Fully illustrate requirements in Contract Documents. Include the following information, as applicable:
 - a. Dimensions.
 - b. Identification of products.
 - c. Schedules.
 - d. Compliance with specified standards.
 - e. Notation of coordination requirements.
 - f. Notation of dimensions established by field measurement.
 - g. Relationship and attachment to adjoining construction clearly indicated.
 - h. Seal and signature of professional engineer if specified.
 2. BIM Incorporation: Develop and incorporate Shop Drawing files into BIM established for Project.
 - 1) Prepare Delegated-Design Drawings in digital data software program, version, and operating system indicated in Document 005433 – Digital Data Letter of Agreement.
 - C. Samples: Submit Samples for review of kind, color, pattern, and texture for a check of these characteristics with other materials.
 1. Transmit Samples that contain multiple, related components such as accessories together in one submittal package.
 2. Identification: Permanently attach label on unexposed side of Samples that includes the following:
 - a. Project name and submittal number.
 - b. Generic description of Sample.
 - c. Product name and name of manufacturer.
 - d. Sample source.
 - e. Number and title of applicable Specification Section.
 - f. Specification paragraph number and generic name of each item.
 - 1) Web-Based Digital Information Management Software: Prepare submittals in PDF form, and upload to web-based [Digital Information Management System](#). Enter required data in [Digital Information Management System](#) to fully identify submittal.
 3. Disposition: Maintain sets of approved Samples at Project site, available for quality-control comparisons throughout the course of construction activity. Sample sets may be used to determine final acceptance of construction associated with each set.
 - a. Samples that may be incorporated into Work are indicated in individual Specification Sections. Ensure Samples are in undamaged condition at time of use.
 - b. Samples not incorporated into Work, or otherwise designated as Owner's property, are property of Contractor.
 4. Samples for Initial Selection: Submit manufacturer's color charts consisting of units or sections of units showing the full range of colors, textures, and patterns available.

- a. Number of Samples: Submit 1 full set of available choices where color, pattern, texture, or similar characteristics are required to be selected from manufacturer's product line. Architect will return submittal with options selected.
5. Samples for Verification: Submit full-size units or Samples of size indicated, prepared from same material to be used for Work, cured and finished in manner specified, and physically identical with material or product proposed for use, and that show full range of color and texture variations expected. Samples include the following: partial sections of manufactured or fabricated components; small cuts or containers of materials; complete units of repetitively used materials; swatches showing color, texture, and pattern; color range sets; and components used for independent testing and inspection.
 - a. Number of Samples: Submit **3 sets** of Samples. Architect will retain **2 Sample sets**; remainder will be returned. [**Mark up and retain 1 returned Sample set as a Project record Sample.**]
 - 1) Submit a single Sample where assembly details, workmanship, fabrication techniques, connections, operation, and other similar characteristics are to be demonstrated.
 - 2) If variation in color, pattern, texture, or other characteristic is inherent in material or product represented by a Sample, submit at least **3 sets** of paired units that show approximate limits of variations.
- D. Product Schedule: As required in individual Specification Sections, prepare a written summary indicating types of products required for Work and their intended location. Include the following information in tabular form:
 1. Type of product. Include unique identifier for each product indicated in Contract Documents or assigned by Contractor if none is indicated.
 2. Manufacturer and product name, and model number if applicable.
 3. Number and name of room or space.
 4. Location within room or space.
- E. Qualification Data: Prepare written information that demonstrates capabilities and experience of firm or person. Include lists of completed projects with project names and addresses, contact information of architects and owners, and other information specified.
- F. Design Data: Prepare and submit written and graphic information indicating compliance with indicated performance and design criteria in individual Specification Sections. Include list of assumptions and summary of loads. Include load diagrams if applicable. Provide name and version of software, if any, used for calculations. Number each page of submittal.
- G. Certificates:
 1. Certificates and Certifications Submittals: Submit a statement that includes signature of entity responsible for preparing certification. Certificates and certifications shall be signed by an officer or other individual authorized to sign documents on behalf of that entity. Provide a notarized signature where indicated.
 2. **[Governmental Certificates: Submit signed copy of Buy American Act compliance certification; Document 004546 – Governmental Certifications.**
 3. [Installer Certificates: Submit written statements on manufacturer's letterhead certifying that Installer complies with requirements in Contract Documents and, where required, is authorized by manufacturer for this specific Project.
 4. Manufacturer Certificates: Submit written statements on manufacturer's letterhead certifying that manufacturer complies with requirements in Contract Documents. Include evidence of manufacturing experience where required.
 5. Material Certificates: Submit written statements on manufacturer's letterhead certifying that material complies with requirements in Contract Documents.
 6. Product Certificates: Submit written statements on manufacturer's letterhead certifying that product complies with requirements in Contract Documents.

7. Welding Certificates: Prepare written certification that welding procedures and personnel comply with requirements in Contract Documents. Submit record of Welding Procedure Specification and Procedure Qualification Record on AWS forms. Include names of firms and personnel certified.
- H. Test and Research Reports:
1. Compatibility Test Reports: Submit reports written by a qualified testing agency, on testing agency's standard form, indicating and interpreting results of compatibility tests performed before installation of product. Include written recommendations for primers and substrate preparation needed for adhesion.
 2. Field Test Reports: Submit written reports indicating and interpreting results of field tests performed either during installation of product or after product is installed in its final location, for compliance with requirements in Contract Documents.
 3. Material Test Reports: Submit reports written by a qualified testing agency, on testing agency's standard form, indicating and interpreting test results of material for compliance with requirements in Contract Documents.
 4. Preconstruction Test Reports: Submit reports written by a qualified testing agency, on testing agency's standard form, indicating and interpreting results of tests performed before installation of product, for compliance with performance requirements in Contract Documents.
 5. Product Test Reports: Submit written reports indicating that current product produced by manufacturer complies with requirements in Contract Documents. Base reports on evaluation of tests performed by manufacturer and witnessed by a qualified testing agency, or on comprehensive tests performed by a qualified testing agency.
 6. Research Reports: Submit written evidence, from a model code organization acceptable to authorities having jurisdiction, that product complies with building code in effect for Project. Include the following information:
 - a. Name of evaluation organization.
 - b. Date of evaluation.
 - c. Time period when report is in effect.
 - d. Product and manufacturers' names.
 - e. Description of product.
 - f. Test procedures and results.
 - g. Limitations of use.
- I. Material Safety Data Sheets (MSDSs): Submit information directly to Owner.
1. Do not submit MSDSs to Architect. If MSDSs are submitted to Architect, Architect will not review submittals that include MSDSs and will return entire submittal.

1.7 DELEGATED-DESIGN SERVICES

- A. Performance and Design Criteria: Where professional design services or certifications by a design professional are specifically required of Contractor by Contract Documents, provide products and systems complying with specific performance and design criteria indicated.
1. If criteria indicated are insufficient to perform services or certification required, submit a written request for additional information to Architect.
- B. Delegated-Design Services Certification:
1. Submit copies of certificate, digitally signed and sealed by Contractor's Delegated-Design Engineer, for each component and system specifically assigned to Contractor as Delegated-Design.
 2. Indicate that components and systems comply with performance and design criteria in Contract Documents.
 3. Include list of codes, loads, and other factors used in performing these services.
 4. Contractor's Delegated-Design Engineer shall comply with the following requirements:
 - a. Performs periodic field review as construction progresses on site.
 - b. Submit report of periodic field review within 3 days of field review.

- c. Submit final letter certifying general conformance with signed and sealed Shop Drawings.
 - C. BIM Incorporation: Incorporate Delegated-Design Drawing and data files into BIM established for Project.
 - 1. Prepare Delegated-Design Drawings in digital data software program, version, and operating system indicated in Document 005433 – Digital Data Letter of Agreement.
- 1.8 CONTRACTOR'S REVIEW
 - A. Action Submittals and Informational Submittals: Review each submittal and check for coordination with other Work of Contract and for compliance with Contract Documents. Note corrections and field dimensions. Mark with approval stamp before submitting to Architect.
 - B. Contractor's Approval: Indicate Contractor's approval for each submittal with a uniform approval stamp. Include name of reviewer, date of Contractor's approval, and statement certifying that submittal has been reviewed, checked, and approved for compliance with Contract Documents.
 - 1. Architect will not review submittals received from Contractor that do not have Contractor's review and approval.
- 1.9 ARCHITECT'S REVIEW
 - A. Action Submittals: Architect will review each submittal, indicate corrections or revisions required, and return it to Contractor as follows:
 - 1. PDF Submittals: Architect will indicate, via markup stamped on each submittal, appropriate action, as follows:
 - a. Reviewed.
 - b. Revise and Resubmit.
 - c. Furnish as Corrected.
 - d. Rejected.
 - 2. Web-Based Project Management Software Submittals: Architect will indicate, on Project management software website, appropriate action based on web-based action options.
 - B. Informational Submittals: Architect will review each submittal and will not return it, or will return it if it does not comply with requirements. Architect will forward each submittal to appropriate party.
 - C. Partial submittals prepared for a portion of Work will be reviewed when use of partial submittals has received prior approval from Architect.
 - D. Incomplete submittals are unacceptable, will be considered nonresponsive, and will be returned for resubmittal without review.
 - E. Architect will return without review or discard submittals received from sources other than Contractor.
 - F. Submittals not required by Contract Documents will be returned by Architect without action.

PART 2 - PRODUCTS (NOT USED)

PART 3 - EXECUTION (NOT USED)

END OF SECTION 013300

SECTION 013573
DELEGATED-DESIGN PROCEDURES

PART 1 - GENERAL

1.1 SUMMARY

- A. Section Includes:
1. Procedures for performing Delegated-Design portions of Work.

1.2 DEFINITIONS

- A. AHJ: Authority Having Jurisdiction.
- B. Applicant: Person applying for building permit and person coordinating Delegated-Design engineered systems with basic building and with each other. Includes coordination of required submittals.
- C. Approval Stamp: Certification that AHJ has reviewed submittal and finds it acceptable with respect to applicable code compliance.
- D. Delegated-Design: Certain components of Work for which Contractor coordinates and assumes or assigns responsibility for design, engineering, calculations, permitting, submittals, fabrication, transportation, and installation.
- E. Delegated-Design Components: Specified products, materials, systems, and other identified items, provided for their intended use.
1. Delegated-Design Components are those subject to gravity, lateral, vertical, wind, and seismic loads not designed by Architect.
 2. Refer to descriptions of Components in individual Specification Sections.
 3. Delegated-Design Components shown in Contract Documents are shown for design intent.
- F. Review Stamp: Certification that Architect has reviewed Drawings, Specifications, computations, and calculations bearing seal of Delegated-Design Engineer, verifying conformance with information given and design concept set forth in Drawings and Specifications.
- G. Seal: Delegated-Design Engineer's certification stamp and signature that Delegated-Design Components were designed and prepared under direct supervision of Delegated-Design Engineer responsible for preparation of Delegated-Design Components.

1.3 ADMINISTRATIVE REQUIREMENTS

- A. Coordination:
1. Coordinate Delegated-Design Components with adjacent products, components, systems, and equipment, whether or not these products, components, systems, and equipment were designed by Architect or are Delegated-Design Components.
- B. Sequencing:
1. Before Work is allowed to proceed, ensure the following:
 - a. Complete, legible documents have been submitted to Building Department.
 - b. Documents have been examined and approved by Building Department.
 2. Documents not completed prior to issuance of building permit shall be completed and submitted for approval prior to fabrication.

1.4 ACTION SUBMITTALS

- A. Delegated-Design Component Submittals: Include the following with submittals:
 - 1. Complete criteria.
 - 2. Design assumptions.
 - 3. Details.
 - 4. Calculations.
 - 5. Structural elements certified by Delegated-Design Engineer.
 - 6. Instructions for fabrication, assembly, installation, and interface with other trades.
- B. Proposed Delegated-Design Engineers: Submit list of engineers proposed for performing Delegated-Design engineering a maximum of 15 days after executing Notice to Proceed.
 - 1. Submit Delegated-Design Summary Sheet to AHJ, if required, listing Delegated-Design Engineers' names, addresses, and telephone numbers prior to issuance of components approval.
- C. Building Department Submittals:
 - 1. 3 sets of design drawings and specifications clearly and legibly showing members, dimensions, connections, and materials, and indicating how component is attached to main structure.
 - a. Design and prepare drawings and specifications stamped by Delegate Design Engineer.
 - b. Drawings and specifications require signature indicating General Design Conformance by Architect.
 - c. Shop Drawings or erection drawing not acceptable for above requirements.
 - 2. Submit 1 set of calculations, including criteria, design assumptions, substantiating computations, and additional data, sufficient to show correctness of drawings and compliance with structural revisions of Structural Specialty Code for the State in which the Project is located .
 - a. Prepare calculations stamped by Delegated-Designed Engineer who prepared drawings.
 - b. Calculations require signing by Architect indicating acceptance of design concepts, loading criteria and compatibility of designs.

1.5 QUALITY ASSURANCE

- A. Delegated-Design Engineer's Qualifications: Professional engineer, registered in the State in which Project is located, engaged by Contractor to provide drawings, specifications, computations, and calculations required by AHJ for Delegated-Design Components and systems.
- B. Specification Sections with Delegated Design Components.
 - 1. Refer to individual Specification Sections for minimum acceptable quality standards for Delegated Design Components.
 - 2. Where quality standards for Delegated Design are not specified in individual Specification Sections, printed industry standards for standard quality practices shall govern.
- C. Owner Responsibilities: Owner will not pay for the following:
 - 1. Progress delays, additional products, additional hours of Work, restocking, or reworking required by Contractor failure to coordinate Delegated Design Work with Project Work.
 - 2. Failure of Contractor to coordinate Delegated-Design Work with Subcontractors, suppliers, fabricators, and other relevant parties.
 - 3. Contractor delays in providing components to meet Project Schedule.
 - 4. Modifying Delegated-Design Documents to incorporate changes required by AHJ.
- D. Architect's Responsibilities:

1. Review Delegated-Design submittals prior to submittal to AHJ for initial and final reviews for limited purpose of checking for general conformance for design intent with information given and design concept expressed in Contract Documents.
 2. Approve or take other appropriate action on submittals consistent with this limited purpose.
 3. Architect not responsible for coordination of Delegated-Design Components with Contract Documents or review of materials submitted as result of Delegated-Design Components.
 4. Architect's review of Delegated-Design submittals does not lessen nor shift burden of Contractor's Delegated-Design responsibilities.
- E. Contractor's Responsibilities:
1. Perform responsibilities for Delegated-Design Work in a timely manner to avoid delays to Project Schedule.
 2. Coordinate and assume or assign to Subcontractors, suppliers, fabricators, and other relevant parties complete responsibility for design, documentation, engineering, calculations, submittals, permits, fabrication, transportation, and installation of this Work.
 3. Submit Delegated-Design Documents to Architect for initial review prior to submitting Documents to AHJ.
 4. Submit Delegated-Design documents to AHJ for initial and final reviews.
 5. Make corrections to Delegated-Design Documents required by AHJ.
 6. Submit Delegated-Design Documents to Architect for final review prior to submitting Documents to AHJ.
 7. Allow sufficient, specified time for Architect's and AHJ's reviews to avoid delays in Project Schedule.
 8. Complete and submit Delegated-Design Summary in format acceptable to Owner and Architect.
- F. Delegated-Design Engineers' Responsibilities:
1. Preparation of Delegated-Design submittals.
 2. Design, coordination, and installation of Delegated-Design Components.
 3. Design anticipated loads and load reactions of Delegated-Design Components attached to, supplemental to, and interfacing with structural frame as indicated on structural Drawings or as required by building code.
 4. Include drawings, specifications, computations, and calculations related to each Delegated-Design Component.
 5. Site Observations: Perform periodic site observations as appropriate to progress of Delegated-Design Work.
 - a. Review progress and quality of Delegated Design Work, including mockup installations that include Delegated-Design Components, to determine if Delegated Design is proceeding in general conformity with Contract Documents, including approved Shop Drawings and design calculations.
 - b. After each site observation, prepare and submit report to Architect and AHJ, if required, and in accordance with applicable building codes.
 - c. Include costs for site observations, including preparation and submitting of reports in Contract Sum.
 6. Completion of Delegated Design-related Work:
 - a. Prepare letter of general conformity for Delegated Design Components of Work certifying that Delegated Design Components have been provided in accordance with requirements of Contract Documents and AHJ.
 - 1) Submit report to Architect and AHJ, if required.
 7. Allow for a review of Delegated-Design by Architect relevant to discipline of Delegated-Design Component.

PART 2 - PRODUCTS (NOT USED)

PART 3 - EXECUTION (NOT USED)

END OF SECTION 013573

SECTION 014000
QUALITY REQUIREMENTS

PART 1 - GENERAL

1.1 SUMMARY

- A. Section Includes:
 - 1. Administrative and procedural requirements for quality assurance and quality control.
- B. Testing and inspection services are required to verify compliance with requirements specified or indicated. These services do not relieve Contractor of responsibility for compliance with Contract Document requirements.
 - 1. Specific quality-assurance and quality-control requirements for individual Work results are specified in their respective Specification Sections. Requirements in individual Sections may also cover production of standard products.
 - 2. Specified tests, inspections, and related actions do not limit Contractor's other quality-assurance and quality-control procedures that facilitate compliance with Contract Document requirements.
 - 3. Requirements for Contractor to provide quality-assurance and quality-control services required by Architect, Owner, Commissioning Authority, or authorities having jurisdiction are not limited by provisions of this Section.
 - 4. Specific test and inspection requirements are specified in other Sections.
- C. Related Requirements:
 - 1. Section 014335 – Mockups.

1.2 DEFINITIONS

- A. Experienced: When used with an entity or individual, "experienced" unless otherwise further described means having successfully completed a minimum of 10 previous projects similar in nature, size, and extent to this Project; being familiar with special requirements indicated; and having complied with requirements of authorities having jurisdiction.
- B. Field Quality-Control Tests: Tests and inspections that are performed on-site for installation of Work and for completed Work.
- C. Installer/Applicator/Erector: Contractor or another entity engaged by Contractor as an employee, subcontractor, or sub-subcontractor, to perform a particular construction operation, including installation, erection, application, assembly, and similar operations.
 - 1. Use of trade-specific terminology in referring to a Work result does not require that certain construction activities specified apply exclusively to specific trade(s).
- D. Preconstruction Testing: Tests and inspections performed specifically for Project before products and materials are incorporated into Work, to verify performance or compliance with specified criteria. Unless otherwise indicated, copies of reports of tests or inspections performed for other than Project do not meet this definition.
- E. Product Tests: Tests and inspections that are performed by a nationally recognized testing laboratory (NRTL) according to 29 CFR 1910.7, by a testing agency accredited according to NIST's National Voluntary Laboratory Accreditation Program (NVLAP), or by a testing agency qualified to conduct product testing and acceptable to authorities having jurisdiction, to establish product performance and compliance with specified requirements.

- F. Quality-Assurance Services: Activities, actions, and procedures performed before and during execution of Work to guard against defects and deficiencies and substantiate that proposed construction will comply with requirements.
- G. Quality-Control Services: Tests, inspections, procedures, and related actions during and after execution of Work to evaluate that actual products incorporated into Work and completed construction comply with requirements. Contractor's quality-control services do not include contract administration activities performed by Architect.
- H. Source Quality-Control Tests: Tests and inspections that are performed at source; for example, plant, mill, factory, or shop.
- I. Testing Agency: Independent entity engaged to perform specific inspections, tests, or both, either at Project site or elsewhere, or to report on and, if required, to interpret results of those inspections or tests.

1.3 DELEGATED-DESIGN SERVICES

- A. Performance and Design Criteria: Where professional design services or certifications by a design professional are specifically required of Contractor by Contract Documents, provide products and systems complying with specific performance and design criteria indicated.
 - 1. If criteria indicated are not sufficient to perform services or certification required, submit a written request for additional information to Architect.
- B. Delegated-Design Services: Submit a statement signed and sealed by responsible design professional, registered in the State in which Project is located, for each product and system specifically assigned to Contractor to be designed or certified by a design professional, indicating that products and systems comply with performance and design criteria indicated.
 - 1. Show ultimate factor of safety.
 - 2. Include list of calculations, codes, and other factors used in performing these services.
 - 3. Prepare calculations in accordance with more stringent of current design rules of Aluminum Association, AISC, AISI, ACI, or these Project Specifications.

1.4 CONFLICTING REQUIREMENTS

- A. Conflicting Standards and Other Requirements: If compliance with 2 or more standards or requirements are specified and standards or requirements establish different or conflicting requirements for minimum quantities or quality levels, comply with most stringent requirement. Refer conflicting requirements that are different, but apparently equal, to Architect for direction before proceeding.
- B. Minimum Quantity or Quality Levels: Quantity or quality level shown or specified shall be minimum provided or performed. Actual installation may comply exactly with minimum quantity or quality specified, or it may exceed minimum within reasonable limits. To comply with these requirements, indicated numeric values are minimum or maximum, as appropriate, for context of requirements. Refer uncertainties to Architect for a decision before proceeding.

1.5 ACTION SUBMITTALS

- A. Mockup Shop Drawings: Comply with requirements in Section 014335 – Mockups.
- B. Delegated-Design Services Submittal: In addition to Shop Drawings, Product Data, and other required submittals, submit a statement signed and sealed by responsible design professional, for each product and system specifically assigned to Contractor to be designed or certified by a design professional, indicating that products and systems comply with performance and design criteria indicated. Include list of codes, loads, and other factors used in performing these services.

1.6 INFORMATIONAL SUBMITTALS

- A. Contractor's Quality-Control Plan: For quality-assurance and quality-control activities and responsibilities.
- B. Qualification Data: For Contractor's quality-control personnel.
- C. Contractor's Statement of Responsibility: When required by authorities having jurisdiction, submit copy of written statement of responsibility submitted to authorities having jurisdiction before starting Work on the following systems:
 - 1. Seismic-force-resisting system, designated seismic system, or component listed in Statement of Special Inspections.
- D. Testing Agency Qualifications: For testing agencies specified in "Quality Assurance" Article to demonstrate their capabilities and experience. Include proof of qualifications in the form of a recent report on the inspection of the testing agency by a recognized authority.
- E. Schedule of Tests and Inspections: Prepare in tabular form and include the following:
 - 1. Specification Section number and title.
 - 2. Entity responsible for performing tests and inspections.
 - 3. Description of test and inspection.
 - 4. Identification of applicable standards.
 - 5. Identification of test and inspection methods.
 - 6. Number of tests and inspections required.
 - 7. Time schedule or time span for tests and inspections.
 - 8. Requirements for obtaining samples.
 - 9. Unique characteristics of each quality-control service.
- F. Reports: Prepare and submit certified written reports and documents as specified.
- G. Permits, Licenses, and Certificates: For Owner's record, submit copies of permits, licenses, certifications, inspection reports, releases, jurisdictional settlements, notices, receipts for fee payments, judgments, correspondence, records, and similar documents established for compliance with standards and regulations bearing on performance of Work.

1.7 CONTRACTOR'S QUALITY-CONTROL PLAN

- A. Testing and Inspection: Prepare a comprehensive schedule of Work requiring testing or inspection, including the following:
 - 1. Contractor-performed tests and inspections including Subcontractor-performed tests and inspections. Include required tests and inspections and Contractor-elected tests and inspections. Distinguish source quality-control tests and inspections from field quality-control tests and inspections.
 - 2. Special inspections required by authorities having jurisdiction and indicated on Statement of Special Inspections.
 - 3. Owner-performed tests and inspections indicated in Contract Documents, including tests and inspections indicated to be performed by Commissioning Authority.
- B. Continuous Inspection of Workmanship: Describe process for continuous inspection during construction to identify and correct deficiencies in workmanship in addition to testing and inspection specified. Indicate types of corrective actions to be required to bring Work into compliance with standards of workmanship established by Contract requirements and approved mockups.
- C. Monitoring and Documentation: Maintain testing and inspection reports including log of approved and rejected results. Include Work Architect has indicated as nonconforming or defective. Indicate corrective actions taken to bring nonconforming Work into compliance with requirements. Comply with requirements of authorities having jurisdiction.

1.8 REPORTS AND DOCUMENTS

- A. Test and Inspection Reports: Prepare and submit certified written reports specified in other Sections. Include the following:
1. Date of issue.
 2. Project title and number.
 3. Name, address, telephone number, and email address of testing agency.
 4. Dates and locations of samples and tests or inspections.
 5. Names of individuals making tests and inspections.
 6. Description of Work and test and inspection method.
 7. Identification of product and Specification Section.
 8. Complete test or inspection data.
 9. Test and inspection results and an interpretation of test results.
 10. Record of temperature and weather conditions at time of sample taking and testing and inspection.
 11. Comments or professional opinion on whether tested or inspected Work complies with Contract Document requirements.
 12. Name and signature of laboratory inspector.
 13. Recommendations on retesting and reinspecting.
- B. Manufacturer's Technical Representative's Field Reports: Prepare written information documenting manufacturer's technical representative's tests and inspections specified in other Sections. Include the following:
1. Name, address, telephone number, and email address of technical representative making report.
 2. Statement on condition of substrates and their acceptability for installation of product.
 3. Statement that products at Project site comply with requirements.
 4. Summary of installation procedures being followed, whether they comply with requirements and, if not, what corrective action was taken.
 5. Results of operational and other tests and a statement of whether observed performance complies with requirements.
 6. Statement whether conditions, products, and installation will affect warranty.
 7. Other required items indicated in individual Specification Sections.
- C. Factory-Authorized Service Representative's Reports: Prepare written information documenting manufacturer's factory-authorized service representative's tests and inspections specified in other Sections. Include the following:
1. Name, address, telephone number, and email address of factory-authorized service representative making report.
 2. Statement that equipment complies with requirements.
 3. Results of operational and other tests and a statement of whether observed performance complies with requirements.
 4. Statement whether conditions, products, and installation will affect warranty.
 5. Other required items indicated in individual Specification Sections.

1.9 QUALITY ASSURANCE

- A. General: Qualifications paragraphs in this Article establish minimum qualification levels required; individual Specification Sections specify additional requirements.
- B. Manufacturer Qualifications: A firm experienced in manufacturing products or systems similar to those indicated for this Project and with a record of successful in-service performance, as well as sufficient production capacity to produce required units. As applicable, procure products from manufacturers able to meet qualification requirements, warranty requirements, and technical or factory-authorized service representative requirements.

- C. Fabricator Qualifications: A firm experienced in producing products similar to those indicated for this Project and with a record of successful in-service performance, as well as sufficient production capacity to produce required units.
- D. Installer Qualifications: A firm or individual experienced in installing, erecting, applying, or assembling work similar in material, design, and extent to that indicated for this Project, whose work has resulted in construction with a record of successful in-service performance.
- E. Professional Engineer Qualifications: A professional engineer who is legally qualified to practice in jurisdiction where Project is located and who is experienced in providing engineering services of kind indicated. Engineering services are defined as those performed for installations of systems, assemblies, or products that are similar in material, design, and extent to those indicated for this Project.
- F. Specialists: Certain Specification Sections require that specific construction activities be performed by entities who are recognized experts in those operations. Specialists shall satisfy qualification requirements indicated and shall be engaged for activities indicated.
 - 1. Requirements of authorities having jurisdiction shall supersede requirements for specialists.
- G. Testing and Inspecting Agency Qualifications: An NRTL, an NVLAP, or an independent agency with experience and capability to conduct testing and inspection indicated, as documented according to ASTM E329; and with additional qualifications specified in individual Sections; and, where required by authorities having jurisdiction, that is acceptable to authorities.
- H. Manufacturer's Technical Representative Qualifications: An authorized representative of manufacturer who is trained and approved by manufacturer to observe and inspect installation of manufacturer's products that are similar in material, design, and extent to those indicated for this Project.
- I. Factory-Authorized Service Representative Qualifications: An authorized representative of manufacturer who is trained and approved by manufacturer to inspect installation of manufacturer's products that are similar in material, design, and extent to those indicated for this Project.
- J. Preconstruction Testing: Where testing agency is indicated to perform preconstruction testing for compliance with specified requirements for performance and test methods, comply with the following:
 - 1. Contractor Responsibilities:
 - a. Provide test specimens representative of proposed products and construction.
 - b. Submit specimens in a timely manner with sufficient time for testing and analyzing results to prevent delaying Work.
 - c. Provide sizes and configurations of test assemblies to adequately demonstrate capability of products to comply with performance requirements.
 - d. Build site-assembled test assemblies using installers who will perform same tasks for Project.
 - e. When testing is complete, remove test specimens and test assemblies. Do not reuse products on Project.
 - f. Build laboratory mockups at testing facility, using personnel, products, and methods of construction indicated for completed Work.
 - 2. Testing Agency Responsibilities:
 - a. Submit a certified written report of each test, inspection, and similar quality-assurance service to Architect and Commissioning Authority, with copy to Contractor.
 - b. Interpret tests and inspections and state in each report whether tested and inspected Work complies with or deviates from Contract Documents.
- K. Mockups: Comply with requirements in Section 014335 – Mockups.

1.10 QUALITY CONTROL

- A. Owner Responsibilities: Where quality-control services are indicated as Owner's responsibility, Owner will engage a qualified testing agency to perform these services.
1. Owner will furnish Contractor with names, addresses, and telephone numbers of testing agencies engaged and a description of types of testing and inspection they are engaged to perform.
 2. Payment for these services will be made **from testing and inspection allowances**, as authorized by Change Orders.
 3. **Costs for retesting and reinspecting construction that replaces or is necessitated by Work that failed to comply with Contract Documents will be charged to Contractor[, and Contract Sum will be adjusted by Change Order].**
- B. Contractor Responsibilities: Tests and inspections not explicitly assigned to Owner are Contractor's responsibility. Perform additional quality-control activities, whether specified or not, to verify and document that Work complies with requirements.
1. Unless otherwise indicated, provide quality-control services specified and those required by authorities having jurisdiction. Perform quality-control services required of Contractor by authorities having jurisdiction, whether specified or not.
 2. Engage a qualified testing agency to perform quality-control services.
 - a. Contractor shall not employ same entity engaged by Owner, unless agreed to in writing by Owner.
 3. Notify testing agencies at least 24 hours in advance of time when Work that requires testing or inspection will be performed.
 4. Where quality-control services are indicated as Contractor's responsibility, submit a certified written report, in duplicate, of each quality-control service.
 5. Testing and inspection requested by Contractor and not required by Contract Documents are Contractor's responsibility.
 6. Submit additional copies of each written report directly to authorities having jurisdiction, when they so direct.
- C. Retesting/Reinspecting: Regardless of whether original tests or inspections were Contractor's responsibility, provide quality-control services, including retesting and reinspecting, for construction that replaced Work that failed to comply with Contract Documents.
- D. Testing Agency Responsibilities: Cooperate with Architect, Commissioning Authority, and Contractor in performance of duties. Provide qualified personnel to perform required tests and inspections.
1. Notify Architect, Commissioning Authority, and Contractor promptly of irregularities or deficiencies observed in Work during performance of its services.
 2. Determine locations from which test samples will be taken and in which in-situ tests are conducted.
 3. Conduct and interpret tests and inspections and state in each report whether tested and inspected Work complies with or deviates from requirements.
 4. Submit a certified written report, in duplicate, of each test, inspection, and similar quality-control service through Contractor.
 5. Do not release, revoke, alter, or increase Contract Document requirements or approve or accept any portion of Work.
 6. Do not perform duties of Contractor.
- E. Manufacturer's Field Services: Where indicated, engage a factory-authorized service representative to inspect field-assembled components and equipment installation, including service connections. Report results in writing as specified in Section 013300 – Submittal Procedures.
- F. Manufacturer's Technical Services: Where indicated, engage a manufacturer's technical representative to observe and inspect Work. Manufacturer's technical representative's services include participation in preinstallation meetings, examination of substrates and conditions,

verification of materials, observation of Installer activities, inspection of completed portions of Work, and submittal of written reports.

- G. Contractor's Associated Requirements and Services: Cooperate with agencies and representatives performing required tests, inspections, and similar quality-control services, and provide reasonable auxiliary services as requested. Notify agency sufficiently in advance of operations to permit assignment of personnel. Provide the following:
1. Access to Work.
 2. Incidental labor and facilities necessary to facilitate tests and inspections.
 3. Adequate quantities of representative samples of materials that require testing and inspection. Assist agency in obtaining samples.
 4. Facilities for storage and field curing of test samples.
 5. Delivery of samples to testing agencies.
 6. Preliminary design mix proposed for use for material mixes that require control by testing agency.
 7. Security and protection for samples and for testing and inspection equipment at Project site.
- H. Coordination: Coordinate sequence of activities to accommodate required quality-assurance and quality-control services with a minimum of delay and to avoid necessity of removing and replacing construction to accommodate testing and inspection.
1. Schedule times for tests, inspections, obtaining samples, and similar activities.
- I. Schedule of Tests and Inspections: Prepare a schedule of tests, inspections, and similar quality-control services required by Contract Documents[**as a component of Contractor's quality-control plan**]. Coordinate and submit concurrently with Contractor's Construction Schedule. Update as Work progresses.
1. Distribution: Distribute schedule to Owner, Architect, Commissioning Authority, testing agencies, and each party involved in performance of portions of Work where tests and inspections are required.

1.11 SPECIAL TESTS AND INSPECTIONS

- A. Special Tests and Inspections: Owner will engage a qualified testing agency or special inspector to conduct special tests and inspections required by authorities having jurisdiction as the responsibility of Owner[, **as indicated in Statement of Special Inspections attached to this Section**], and as follows:
1. Verifying that manufacturer maintains detailed fabrication and quality-control procedures and reviewing completeness and adequacy of those procedures to perform Work.
 2. Notifying Architect, Commissioning Authority, and Contractor promptly of irregularities and deficiencies observed in Work during performance of its services.
 3. Submitting a certified written report of each test, inspection, and similar quality-control service to Architect and Commissioning Authority with copy to Contractor and to authorities having jurisdiction.
 4. Submitting a final report of special tests and inspections at Substantial Completion, which includes a list of unresolved deficiencies.
 5. Interpreting tests and inspections and stating in each report whether tested and inspected Work complies with or deviates from Contract Documents.
 6. Retesting and reinspecting corrected Work.
- B. Special Tests and Inspections: Conducted by a qualified testing agency or special inspector as required by authorities having jurisdiction, as indicated in individual Specification Sections[**and in the Statement of Special Inspections attached to this Section**], and as follows:
1. Verifying that manufacturer maintains detailed fabrication and quality-control procedures and reviewing completeness and adequacy of those procedures to perform Work.
 2. Notifying Architect, Commissioning Authority, and Contractor promptly of irregularities and deficiencies observed in the Work during performance of its services.

3. Submitting a certified written report of each test, inspection, and similar quality-control service to Architect and Commissioning Authority with copy to Contractor and to authorities having jurisdiction.
4. Submitting a final report of special tests and inspections at Substantial Completion, which includes a list of unresolved deficiencies.
5. Interpreting tests and inspections and stating in each report whether tested and inspected Work complies with or deviates from Contract Documents.
6. Retesting and reinspecting corrected Work.

PART 2 - PRODUCTS (NOT USED)

PART 3 - EXECUTION

3.1 TEST AND INSPECTION LOG

- A. Test and Inspection Log: Prepare a record of tests and inspections. Include the following:
 1. Date test or inspection was conducted.
 2. Description of Work tested or inspected.
 3. Date test or inspection results were transmitted to Architect.
 4. Identification of testing agency or special inspector conducting test or inspection.
- B. Maintain log at Project site. Post changes and revisions as they occur. Provide access to test and inspection log for Architect's, Commissioning Authority's, reference during normal working hours.
 1. Submit log at Project closeout as part of Project Record Documents.

3.2 REPAIR AND PROTECTION

- A. General: On completion of testing, inspection, sample taking, and similar services, repair damaged construction and restore substrates and finishes.
 1. Provide materials and comply with installation requirements specified in other Specification Sections or matching existing substrates and finishes. Restore patched areas and extend restoration into adjoining areas with durable seams that are as invisible as possible. Comply with Contract Document requirements for cutting and patching in Section 017300 – Execution.
- B. Protect construction exposed by or for quality-control service activities.
- C. Repair and protection are Contractor's responsibility, regardless of assignment of responsibility for quality-control services.

END OF SECTION 014000

SECTION 014200

REFERENCES

PART 1 - GENERAL

1.1 DEFINITIONS

- A. General: Basic Contract definitions are included in Conditions of the Contract. Other definitions are included in individual Specification Documents and Sections.
- B. Addenda: Written and/or graphic instruments issued by Architect prior to execution of Contract that modify or interpret Bidding Documents by additions, deletions, clarifications, or corrections. Addenda become part of Contract Documents when Construction Contract is executed.
- C. Approved: When used to convey Architect's action on Contractor's submittals, applications, and requests, "approved" is limited to Architect's duties and responsibilities as stated in the Conditions of the Contract.
- D. Authority Having Jurisdiction (AHJ): Agency or individual officially empowered to enforce the building, fire and life safety code requirements of the permitting jurisdiction in which the Project is located.
- E. By Owner (BO): Items that will be ordered, paid for, and shipped to Project by Owner. Contractor shall receive, unload, unpack or uncrate, protect, move into place, install, and connect these items as specified or indicated in Contract Documents.
- F. Directed: A command or instruction by Architect. Other terms including "requested," "authorized," "selected," "required," and "permitted" have the same meaning as "directed."
- G. Experienced: When used with an entity or individual, "experienced" unless otherwise further described means having successfully completed a minimum of 5 previous projects similar in nature, size, and extent to this Project; being familiar with special requirements indicated; and having complied with requirements of authorities having jurisdiction.
- H. Furnish: Supply and deliver to Project site, ready for unloading, unpacking, assembly, installation, and similar operations.
- I. Herein: Contents of a particular Specification Section, or contents within any or all of parts and sections of Conditions of the Contract (General and Supplementary Conditions) and Division 01 - General Requirements.
- J. Indicated: Requirements expressed by graphic representations or in written form on Drawings, in Specifications, and in other Contract Documents. Other terms including "shown," "noted," "scheduled," and "specified" have the same meaning as "indicated."
- K. Install: Unload, temporarily store, unpack, assemble, erect, place, anchor, apply, work to dimension, finish, cure, protect, clean, and similar operations at Project site.
- L. Installer/Erector/Applicator: Contractor or another entity engaged by Contractor, either as an employee, Subcontractor, or Sub-subcontractor, to perform a particular construction operation, including installation, erection, application, and similar operations.
 - 1. Installers shall be experienced in operations in which they are engaged to perform.
 - 2. Use of trade-specific terminology in referring to a trade or entity does not require that certain construction activities be performed by accredited or unionized individuals, or that requirements specified apply exclusively to specific trade(s).
- M. (NIC) Not in Contract. Products not in Contract, but which may require provisions in construction for future installation by others.

- N. OFOI: Owner furnished – Owner installed.
 - O. OFCI: Owner furnished – Contractor installed.
 - P. Product: Material, machinery, components, equipment, fixtures, and systems forming Work result. Not materials or equipment used for preparation, fabrication, conveying, or erection, and not incorporated into Work result. Products may be new, never before used, or re-used materials or equipment.
 - Q. Project Manual: A volume assembled for the Work that may include Bidding requirements, sample forms, Conditions of the Contract, and Specifications.
 - R. Project Site: Space available for performing construction activities. Extent of Project site is shown on Drawings and may or may not be identical with description of land on which Project is to be built.
 - S. Provide: Furnish and install, complete and ready for intended use.
 - T. Regulations: Laws, ordinances, statutes, and lawful orders issued by authorities having jurisdiction, and rules, conventions, and agreements within the construction industry that control performance of the Work.
 - U. Trades: Using terms such as carpentry is not intended to imply that accredited or unionized individuals of corresponding generic name, such as carpenter, must perform certain construction activities. It also does not imply that requirements specified apply exclusively to tradespeople of corresponding generic name.
- 1.2 HUD STANDARDS
- A. Contractor shall comply with HUD 221 (d) Requirements
 - B. Contractor shall comply with HUD Use of Materials Bulletins listed in applicable sections
- 1.3 INDUSTRY STANDARDS
- A. Applicability of Standards: Unless Contract Documents include more stringent requirements, applicable construction industry standards have same force and effect as if bound or copied directly into Contract Documents to extent referenced. Such standards are made a part of Contract Documents by reference.
 - B. Publication Dates: Comply with standards in effect as of date of Contract Documents unless otherwise indicated.
 - C. Copies of Standards: Each entity engaged in construction on Project should be familiar with industry standards applicable to its construction activity. Copies of applicable standards are not bound with Contract Documents.
 - 1. Where copies of standards are needed to perform a required construction activity, obtain copies directly from publication source.
- 1.4 ABBREVIATIONS AND ACRONYMS
- A. Industry Organizations: Where abbreviations and acronyms are used in Specifications or other Contract Documents, they shall mean the recognized name of entities indicated in Gale's "Encyclopedia of Associations: National Organizations of the U.S." or in Columbia Books' "National Trade & Professional Associations of the United States."
 - B. Industry Organizations: Where abbreviations and acronyms are used in Specifications or other Contract Documents, they shall mean the recognized name of entities in the following list. This information is subject to change and is believed to be accurate as of date of Contract Documents.
 - 1. AABC - Associated Air Balance Council; www.aabc.com.

2. AAMA - American Architectural Manufacturers Association; www.aamanet.org.
3. AASHTO - American Association of State Highway and Transportation Officials; www.transportation.org.
4. AATCC - American Association of Textile Chemists and Colorists; www.aatcc.org.
5. ABMA - American Bearing Manufacturers Association; www.americanbearings.org.
6. ABMA - American Boiler Manufacturers Association; www.abma.com.
7. ACI - American Concrete Institute; (Formerly: ACI International); www.concrete.org
8. ACPA - American Concrete Pipe Association; www.concrete-pipe.org.
9. AEIC - Association of Edison Illuminating Companies, Inc. (The); www.aeic.org.
10. AF&PA - American Forest & Paper Association; www.afandpa.org.
11. AGA - American Gas Association; www.aga.org.
12. AHAM - Association of Home Appliance Manufacturers; www.aham.org.
13. AHRI - Air-Conditioning, Heating, and Refrigeration Institute (The); www.ahrinet.org.
14. AI - Asphalt Institute; www.asphaltinstitute.org.
15. AIA - American Institute of Architects (The); www.aia.org.
16. AISC - American Institute of Steel Construction; www.aisc.org.
17. AISI - American Iron and Steel Institute; www.steel.org.
18. AITC - American Institute of Timber Construction; www.aitc-glulam.org.
19. AMCA - Air Movement and Control Association International, Inc.; www.amca.org.
20. ANSI - American National Standards Institute; www.ansi.org.
21. AOSA - Association of Official Seed Analysts, Inc.; www.aosaseed.com.
22. APA - The Engineered Wood Association; www.apawood.org.
23. APA - Architectural Precast Association; www.archprecast.org.
24. API - American Petroleum Institute; www.api.org.
25. ARI - Air-Conditioning & Refrigeration Institute; (See AHRI).
26. ARI - American Refrigeration Institute; (See AHRI).
27. ARMA - Asphalt Roofing Manufacturers Association; www.asphaltroofing.org.
28. ASCE - American Society of Civil Engineers; www.asce.org.
29. ASCE/SEI - American Society of Civil Engineers/Structural Engineering Institute; (See ASCE).
30. ASHRAE - American Society of Heating, Refrigerating and Air-Conditioning Engineers; www.ashrae.org.
31. ASME - ASME International; (American Society of Mechanical Engineers); www.asme.org.
32. ASSE - American Society of Safety Engineers (The); www.asse.org.
33. ASSE - American Society of Sanitary Engineering; www.asse-plumbing.org.
34. ASTM - ASTM International; www.astm.org.
35. ATIS - Alliance for Telecommunications Industry Solutions; www.atis.org.
36. AWI - Architectural Woodwork Institute; www.awinet.org.
37. JAWPA - American Wood Protection Association; www.awpa.com.
38. AWS - American Welding Society; www.aws.org.
39. AWWA - American Water Works Association; www.awwa.org.
40. BHMA - Builders Hardware Manufacturers Association; www.buildershardware.com.
41. BIA - Brick Industry Association (The); www.gobrick.com.
42. BIFMA - BIFMA International; (Business and Institutional Furniture Manufacturer's Association); www.bifma.org.
43. CDA - Copper Development Association; www.copper.org.
44. CEA - Consumer Electronics Association; www.ce.org.
45. CFFA - Chemical Fabrics and Film Association, Inc.; www.chemicalfabricsandfilm.com.
46. CFSEI - Cold-Formed Steel Engineers Institute; www.cfsei.org.
47. CGA - Compressed Gas Association; www.cganet.com.
48. CIMA - Cellulose Insulation Manufacturers Association; www.cellulose.org.
49. CISCA - Ceilings & Interior Systems Construction Association; www.cisca.org.
50. CISPI - Cast Iron Soil Pipe Institute; www.cispi.org.
51. CLFMI - Chain Link Fence Manufacturers Institute; www.chainlinkinfo.org.
52. CPA - Composite Panel Association; www.pbmdf.com.
53. CRI - Carpet and Rug Institute (The); www.carpet-rug.org.

54. CRRC - Cool Roof Rating Council; www.coolroofs.org.
55. CRSI - Concrete Reinforcing Steel Institute; www.crsi.org.
56. CSA - CSA Group; www.csa.ca.
57. CSA - CSA International; (Formerly: IAS - International Approval Services); www.csa-international.org.
58. CSI - Construction Specifications Institute (The); www.csinet.org.
59. JCTI - Cooling Technology Institute; (Formerly: Cooling Tower Institute); www.cti.org.
60. CWC - Composite Wood Council; (See CPA).
61. DASMA - Door and Access Systems Manufacturers Association; www.dasma.com.
62. DHI - Door and Hardware Institute; www.dhi.org.
63. ECA - Electronic Components Association; (See ECIA).
64. ECAMA - Electronic Components Assemblies & Materials Association; (See ECIA).
65. ECIA - Electronic Components Industry Association; www.eciaonline.org.
66. EIA - Electronic Industries Alliance; (See TIA).
67. EJMA - Expansion Joint Manufacturers Association, Inc.; www.ejma.org.
68. ESD - ESD Association; (Electrostatic Discharge Association); www.esda.org.
69. ESDS – Evergreen Sustainable Development Standard
70. ETL - Intertek (See Intertek); www.intertek.com.
71. EVO - Efficiency Valuation Organization; www.evo-world.org.
72. FCI - Fluid Controls Institute; www.fluidcontrolsintstitute.org.
73. FM Approvals - FM Approvals LLC; www.fmglobal.com.
74. FM Global - FM Global; (Formerly: FMG - FM Global); www.fmglobal.com.
75. FSA - Fluid Sealing Association; www.fluidsealing.com.
76. FSC - Forest Stewardship Council U.S.; www.fscus.org.
77. GA - Gypsum Association; www.gypsum.org.
78. GANA - Glass Association of North America; www.glasswebsite.com.
79. **[GS - Green Seal; www.greenseal.org.**
80. JHI - Hydraulic Institute; www.pumps.org.
81. HI/GAMA - Hydronics Institute/Gas Appliance Manufacturers Association; (See AHRI).
82. HMMA - Hollow Metal Manufacturers Association; (See NAAMM).
83. HPVA - Hardwood Plywood & Veneer Association; www.hpva.org.
84. HPW - H. P. White Laboratory, Inc.; www.hpwhite.com.
85. IAPSC - International Association of Professional Security Consultants; www.iapsc.org.
86. IAS - International Accreditation Service; www.iaonline.org.
87. IAS - International Approval Services; (See CSA).
88. ICBO - International Conference of Building Officials; (See ICC).
89. ICC - International Code Council; www.iccsafe.org.
90. ICEA - Insulated Cable Engineers Association, Inc.; www.icea.net.
91. ICPA - International Cast Polymer Alliance; www.icpa-hq.org.
92. ICRI - International Concrete Repair Institute, Inc.; www.icri.org.
93. IEC - International Electrotechnical Commission; www.iec.ch.
94. IEEE - Institute of Electrical and Electronics Engineers, Inc. (The); www.ieee.org.
95. IES - Illuminating Engineering Society; (Formerly: Illuminating Engineering Society of North America); www.ies.org.
96. IESNA - Illuminating Engineering Society of North America; (See IES).
97. IEST - Institute of Environmental Sciences and Technology; www.iest.org.
98. IGMA - Insulating Glass Manufacturers Alliance; www.igmaonline.org.
99. IGSHPA - International Ground Source Heat Pump Association; www.igshpa.okstate.edu.
100. JIntertek - Intertek Group; (Formerly: ETL SEMCO; Intertek Testing Service NA); www.intertek.com.
101. ISA - International Society of Automation (The); (Formerly: Instrumentation, Systems, and Automation Society); www.isa.org.
102. ISAS - Instrumentation, Systems, and Automation Society (The); (See ISA).
103. ISFA - International Surface Fabricators Association; (Formerly: International Solid Surface Fabricators Association); www.isfanow.org.

104. ISO - International Organization for Standardization; www.iso.org.
105. ISSFA - International Solid Surface Fabricators Association; (See ISFA).
106. ITU - International Telecommunication Union; www.itu.int/home.
107. JLMA - Laminating Materials Association; (See CPA).
108. LPI - Lightning Protection Institute; www.lightning.org.
109. JMCA - Metal Construction Association; www.metalconstruction.org.
110. JMFMA - Metal Framing Manufacturers Association, Inc.; www.metalframingmfg.org.
111. MHIA - Material Handling Industry of America; www.mhia.org.
112. MIA - Marble Institute of America; www.marble-institute.com.
113. MMPA - Moulding & Millwork Producers Association; www.wmmpa.com.
114. MPI - Master Painters Institute; www.paintinfo.com.
115. MSS - Manufacturers Standardization Society of The Valve and Fittings Industry Inc.; www.mss-hq.org.
116. NAAMM - National Association of Architectural Metal Manufacturers; www.naamm.org.
117. NAAWS - North American Architectural Woodwork Standards; <https://www.naaws-committee.com>.
118. NADCA - National Air Duct Cleaners Association; www.nadca.com.
119. NAIMA - North American Insulation Manufacturers Association; www.naima.org.
120. NBGQA - National Building Granite Quarries Association, Inc.; www.nbgqa.com.
121. NBI - New Buildings Institute; www.newbuildings.org.
122. JNCMA - National Concrete Masonry Association; www.ncma.org.
123. NEBB - National Environmental Balancing Bureau; www.nebb.org.
124. NECA - National Electrical Contractors Association; www.necanet.org.
125. JNEMA - National Electrical Manufacturers Association; www.nema.org.
126. NETA - InterNational Electrical Testing Association; www.netaworld.org.
127. JNFPA - National Fire Protection Association; www.nfpa.org.
128. NFPA - NFPA International; (See NFPA).
129. NFRC - National Fenestration Rating Council; www.nfrc.org.
130. NHLA - National Hardwood Lumber Association; www.nhla.com.
131. **JNLGA - National Lumber Grades Authority; www.nlga.org.**
132. JNOMMA - National Ornamental & Miscellaneous Metals Association; www.nomma.org.
133. NRCA - National Roofing Contractors Association; www.nrca.net.
134. NRMCA - National Ready Mixed Concrete Association; www.nrmca.org.
135. NSF - NSF International; www.nsf.org.
136. NSPE - National Society of Professional Engineers; www.nspe.org.
137. **JNSSGA - National Stone, Sand & Gravel Association; www.nssga.org.**
138. JPCI - Precast/Prestressed Concrete Institute; www.pci.org.
139. PDI - Plumbing & Drainage Institute; www.pdionline.org.
140. RCSC - Research Council on Structural Connections; www.boltcouncil.org.
141. RFCI - Resilient Floor Covering Institute; www.rfci.com.
142. JSAE - SAE International; www.sae.org.
143. SCTE - Society of Cable Telecommunications Engineers; www.scte.org.
144. SDI - Steel Deck Institute; www.sdi.org.
145. SDI - Steel Door Institute; www.steeldoor.org.
146. SEFA - Scientific Equipment and Furniture Association (The); www.sefalabs.com.
147. SEI/ASCE - Structural Engineering Institute/American Society of Civil Engineers; (See ASCE).
148. SIA - Security Industry Association; www.siaonline.org.
149. SJJ - Steel Joist Institute; www.steeljoist.org.
150. **JSMASMA - Screen Manufacturers Association; www.smainfo.org.**
151. JSMACNA - Sheet Metal and Air Conditioning Contractors' National Association; www.smacna.org.
152. SPFA - Spray Polyurethane Foam Alliance; www.sprayfoam.org.
153. **JSPIB - Southern Pine Inspection Bureau; www.spib.org.**
154. **SPRI - Single Ply Roofing Industry; www.spri.org.**
155. JSRCC - Solar Rating & Certification Corporation; www.solar-rating.org.

156. SSINA - Specialty Steel Industry of North America; www.ssina.com.
 157. SSPC - SSPC: The Society for Protective Coatings; www.sspc.org.
 158. STI - Steel Tank Institute; www.steeltank.com.
 159. JSWPA - Submersible Wastewater Pump Association; www.swpa.org.
 160. JTCNA - Tile Council of North America, Inc.; www.tileusa.com.
 161. TEMA - Tubular Exchanger Manufacturers Association, Inc.; www.tema.org.
 162. TIA - Telecommunications Industry Association (The); (Formerly: TIA/EIA - Telecommunications Industry Association/Electronic Industries Alliance); www.tiaonline.org.
 163. TMS - The Masonry Society; www.masonrysociety.org.
 164. **[TPI - Truss Plate Institute; www.tpinst.org.**
 165. **][TPI - Turfgrass Producers International; www.turfgrassod.org.**
 166. JUL - Underwriters Laboratories Inc.; <http://www.ul.com>.
 167. UNI - Uni-Bell PVC Pipe Association; www.uni-bell.org.
 168. JWA - Wallcoverings Association; www.wallcoverings.org
 169. WASTEC - Waste Equipment Technology Association; www.wastec.org.
 170. WCLIB - West Coast Lumber Inspection Bureau; www.wclib.org.
 171. WCMA - Window Covering Manufacturers Association; www.wcmanet.org.
 172. WDMA - Window & Door Manufacturers Association; www.wdma.com.
 173. **[WI - Woodwork Institute; www.wicnet.org.**
 174. JWWPA - Western Wood Products Association; www.wwpa.org.
- C. Code Agencies: Where abbreviations and acronyms are used in Specifications or other Contract Documents, they shall mean the recognized name of entities in the following list. This information is believed to be accurate as of the date of Contract Documents.
1. IAPMO - International Association of Plumbing and Mechanical Officials; www.iapmo.org.
 2. ICC - International Code Council; www.iccsafe.org.
 3. ICC-ES - ICC Evaluation Service, LLC; www.icc-es.org.
- D. Federal Government Agencies: Where abbreviations and acronyms are used in Specifications or other Contract Documents, they shall mean recognized name of entities in the following list. Information is subject to change and is up to date as of the date of Contract Documents.
1. CPSC; Consumer Product Safety Commission; www.cpsc.gov.
 2. DOC; Department of Commerce; National Institute of Standards and Technology; www.nist.gov.
 3. JDOE; Department of Energy; www.energy.gov.
 4. EPA; Environmental Protection Agency; www.epa.gov.
 5. JFG; Federal Government Publications; www.gpo.gov/fdsys.
 6. GSA; General Services Administration; www.gsa.gov.
 7. **[HUD; Department of Housing and Urban Development; www.hud.gov.**
 8. JLBL; Lawrence Berkeley National Laboratory; Environmental Energy Technologies Division; www.eetd.lbl.gov.
 9. OSHA; Occupational Safety & Health Administration; www.osha.gov.
 10. SD; Department of State; www.state.gov.
 11. TRB; Transportation Research Board; National Cooperative Highway Research Program; The National Academies; www.trb.org.
 12. USDA; Department of Agriculture; Agriculture Research Service; U.S. Salinity Laboratory; www.ars.usda.gov.
 13. **USPS; United States Postal Service; www.usps.com.]**
- E. Standards and Regulations: Where abbreviations and acronyms are used in Specifications or other Contract Documents, they shall mean the recognized name of standards and regulations in the following list. This information is subject to change and is believed to be accurate as of the date of Contract Documents.
1. CFR; Code of Federal Regulations; Available from Government Printing Office; www.gpo.gov/fdsys.
 2. FED-STD; Federal Standard; (See FS).

3. FS; Federal Specification; Available from DLA Document Services; www.quicksearch.dla.mil.
 4. Available from General Services Administration; www.gsa.gov.
 5. Available from National Institute of Building Sciences/Whole Building Design Guide; www.wbdg.org/ccb.
 6. USAB; United States Access Board; www.access-board.gov.
- F. State Government Agencies: Where abbreviations and acronyms are used in Specifications or other Contract Documents, they shall mean recognized name of entities in the following list. This information is subject to change and is believed to be accurate as of the date of Contract Documents.
1. CDHS; California Department of Health Services; (See CDPH).
 2. CDPH; California Department of Public Health; Indoor Air Quality Program; www.cal-iaq.org.
 3. SBC; Seattle Building Code; <http://www.seattle.gov/dpd>.
 4. SCAQMD; South Coast Air Quality Management District; www.aqmd.gov.
 5. WABO; Washington Association of Building Officials; <http://www.wabo.org>.

PART 2 - PRODUCTS (NOT USED)

PART 3 - EXECUTION (NOT USED)

END OF SECTION 014200

SECTION 014339

MOCKUPS

PART 1 - GENERAL

1.1 SUMMARY

A. Section Includes:

1. Administrative and procedural requirements for quality assurance and quality control of mockups.

B. Related Requirements:

1. Section 014000 – Quality Requirements, for the following related to mockups:
 - a. Testing and inspection services.
 - b. Delegated-Design Services.
 - c. Contractor's quality-control plan.
 - d. Schedule of tests and inspections.
 - e. Conflicting requirements.
 - f. Additional related definitions.

1.2 DEFINITIONS

- ###### A. Mockups: Full-size physical assemblies that are constructed on-site either as freestanding temporary built elements or as part of permanent construction. Mockups are constructed to verify selections made under Sample submittals; to demonstrate aesthetic effects and qualities of materials and execution; to review coordination, testing, or operation; to show interface between dissimilar materials; and to demonstrate compliance with specified installation tolerances to indicate workmanship. Mockups are not Samples. Unless otherwise indicated, approved mockups establish the standard by which Work will be judged.

1. Laboratory Mockups: Full-size physical assemblies constructed and tested at testing facility to verify performance characteristics.
2. Integrated Exterior Mockups: Mockups of the exterior envelope constructed on-site as **[freestanding temporary built elements] [as indicated in-place portions of permanent construction]**, consisting of multiple products, assemblies, and subassemblies, with cutaways enabling inspection of concealed portions of the Work.
 - a. Include each system, assembly, component, and part of exterior wall **[and roof]** to be constructed for Project. Colors of components shall be those selected by Architect for use in Project.
3. Room Mockups: Mockups of typical interior spaces complete with wall, floor, and ceiling finishes; doors; windows; millwork; casework; specialties; furnishings and equipment; and lighting.
4. Product Mockups: Mockups that may include multiple products, materials, or systems specified in a single Section.
5. In-Place Mockups: Mockups constructed on-site in their actual final location as part of permanent construction.

1.3 ADMINISTRATIVE REQUIREMENTS

A. Coordination:

1. Coordinate sequence of activities to accommodate required quality-assurance and quality-control services indicated in Section 014000 – Quality Requirements with a minimum of delay and to avoid necessity of removing and replacing construction to accommodate testing and inspection.
2. Schedule times for tests, inspections, and similar activities.

- B. Preinstallation Meetings: Conduct meetings at Project site.
 - 1. Timing: A minimum of 7 days prior to starting construction of mockups
 - 2. Attendees: Owner, Architect, Contractor, each specialist, supplier, Installer, testing agent, and other entities involved in construction of respective mockups. Participants shall be familiar with Project and authorized to conclude matters relating to mockup Work.
 - 3. Project Schedule. Verify availability of materials, Installer's personnel, equipment, and facilities needed for each mockup.
 - a. Include line item in Project schedule for integrated exterior mockups, showing submittals, construction, review, and approval periods.
 - 4. Review materials, methods, and procedures related to mockups.
 - 5. Required testing, inspecting, and certifying procedures.
- C. Scheduling:
 - 1. Allow sufficient time in Project schedule for construction of mockups as necessary to allow testing, modifications to failed mockups, and retesting, in addition to obtaining Architect's approval to avoid delays in Project schedule.
 - a. Update Construction Schedule to reflect required revisions to mockups.
 - 2. Do not proceed with ordering of materials or start building construction until mockups have been approved by Architect.

1.4 ACTION SUBMITTALS

- A. Shop Drawings: For integrated exterior mockups.
 - 1. Include plans, sections, and elevations, indicating materials and size of mockup construction.
 - 2. Indicate manufacturer and model number of individual components.
 - 3. Include the following in Shop Drawings:
 - a. Half size details of conditions for every member, joint, anchorage, weld size, glazing system, wall panel system, and provisions for expansion and contraction and sealant application.
 - b. Axonometric drawings for conditions difficult to illustrate in 2 dimensions.
 - c. Coordination details for related and adjoining Work. Insert templates and erection diagrams to completely describe and construct mockup.

1.5 REPORTS AND DOCUMENTS

- A. Test and Inspection Reports: Prepare and submit certified written reports indicated in Section 014000 and as specified in other Sections.

1.6 QUALITY ASSURANCE

- A. General: Qualifications paragraphs in this Article establish minimum qualification levels required; individual Specification Sections specify additional requirements.
 - 1. Comply with further requirements in Section 014000 – Quality Requirements.
- B. Preconstruction Testing: Where testing agency is indicated to perform preconstruction testing for compliance with specified requirements for performance and test methods, comply with the following:
 - 1. Contractor Responsibilities:
 - a. Provide test specimens representative of proposed products and construction.
 - b. Submit specimens in a timely manner with sufficient time for testing and analyzing results to prevent delaying Work.
 - c. Provide sizes and configurations of integrated exterior mockups to adequately demonstrate capability of products to comply with performance requirements.
 - d. Build site-assembled mockups using installers who will perform same tasks for Project.
 - e.]When testing is complete, remove test specimens and test assemblies, and mockups, unless indicated to remain as part of completed Work; do not reuse products on Project.

2. Testing Agency Responsibilities: Submit a certified written report of each test, inspection, and similar quality-assurance service to Architect and Commissioning Authority, with copy to Contractor. Interpret tests and inspections and state in each report whether tested and inspected Work complies with or deviates from Contract Documents.

1.7 MOCKUPS

- A. Before installing portions of the Work requiring mockups, build mockups for each form of construction and finish required to comply with the following requirements, using materials indicated for completed Work.
 1. Build types of mockups as indicated below
 2. Build mockups in location indicated or, if not indicated, as directed by Architect.
 3. Notify Architect **7 days** in advance of dates and times when mockups will be constructed.
 4. Employ supervisory personnel who will oversee mockup construction. Employ workers that will be employed to perform same tasks during construction at Project.
 5. Demonstrate proposed range of aesthetic effects and workmanship.
 6. Obtain Architect's approval of mockups before starting corresponding Work, fabrication, or construction.
 - a. Allow 7 days for initial review and each re-review of each mockup.
 7. Promptly correct unsatisfactory conditions noted by Architect's preliminary review, to satisfaction of Architect, before completion of final mockup.
 8. Perform testing on mockups according to requirements in Section 014000 – Quality Requirements.
 9. Approval of mockups does not constitute approval of deviations from Contract Documents contained in mockups unless Architect specifically approves such deviations in writing.
 10. Maintain mockups during construction in an undisturbed condition as a standard for judging completed Work.
 11. Subject to compliance with requirements, approved mockups may become part of completed Work if undisturbed at time of Substantial Completion unless indicated otherwise.
 12. Where mockups not indicated to remain on completed Work, demolish and remove mockups when directed.
- B. Integrated Exterior Mockups: Construct integrated exterior mockup according to approved Shop Drawings, as indicated in Specifications, or indicated on Drawings. Coordinate installation of exterior envelope materials and products for which mockups are required in individual Specification Sections, along with supporting materials. Comply with requirements in "Mockups" Paragraph.
 1. Coordinate construction of mockup to allow observation of air barrier installation, flashings, air barrier integration with fenestration systems, and other portions of building air/moisture barrier and drainage assemblies, prior to installation of veneer, cladding elements, and other components that will obscure Work.

1.8 QUALITY CONTROL

- A. Comply with requirements in Section 014000 – Quality Requirements for quality control services related to mockups.

1.9 SPECIAL TESTS AND INSPECTIONS

- A. Comply with requirements in Section 014000 – Quality Requirements for special tests and inspections related to mockups.

PART 2 - PRODUCTS

- A. Materials and Finishes, General: Incorporate products, materials, equipment, systems, and other items into mockups as indicated in individual Specification Sections.

1. Comply with requirements specified in Contract Documents, and match previously submitted and approved Shop Drawings and Samples.

PART 3 - EXECUTION

3.1 PREPARATION

- A. Ensure areas indicated for mockups are ready to receive this Work.
- B. Do not proceed with mockup Work until each product, material, and component of mockup is available and ready for installation.

3.2 INSTALLATION

- A. Build mockups incorporating products, materials, equipment, systems, and other items indicated in accordance with relevant Specification Sections.
- B. Duplicate conditions and methods proposed for final construction.
- C. Sequence installation to demonstrate that materials and systems forming exterior walls meet design intent.

3.3 FIELD QUALITY CONTROL

- A. Comply with Section 014000 – Quality Requirements and requirements of individual Specification Sections of products, materials, and components included in mockups for testing and inspections of mockup Work.

3.4 REPAIR

- A. On completion of testing, inspection, sample-taking, and similar services, repair damaged construction and restore substrates and finishes on mockups indicated to remain in completed Work.
 1. Provide materials and comply with installation requirements specified in other Specification Sections[**or matching existing substrates and finishes**]. Restore patched areas and extend restoration into adjoining areas with durable seams that are as invisible as possible.[**Comply with Contract Document requirements for cutting and patching in Section 017300 – Execution.**]
- B. Repair is Contractor's responsibility, regardless of assignment of responsibility for quality-control services.

3.5 CLEANING

- A. When authorized by Architect, demolish, remove, and legally dispose of mockup materials not indicated to remain in completed Work.

3.6 PROTECTION

- A. On completion of mockup Work, provide relevant protection of mockups indicated to remain in completed Work. Use protective materials properly suited for the various components.
- B. Repair and protection is Contractor's responsibility, regardless of assignment of responsibility for quality-control services.

END OF SECTION 014339

SECTION 015000
TEMPORARY FACILITIES AND CONTROLS

PART 1 - GENERAL

1.1 SUMMARY

A. Section Includes:

1. Requirements for temporary utilities, support facilities, and security and protection facilities.

1.2 USE CHARGES

- A. Include installation, removal, and use charges for temporary facilities in Contract Sum unless otherwise indicated. Allow other entities engaged in Project to use temporary services and facilities without cost, including [**Owner's construction forces,**] Architect, [**occupants of Project,**] testing agencies, and authorities having jurisdiction.
- B. Sewer Service: Pay sewer-service use charges for sewer usage by entities for construction operations.
- C. Water Service: Pay water-service use charges for water used by entities for construction operations.
- D. Electric Power Service: Pay electric-power-service use charges for electricity used by entities for construction operations.
- E. Water and Sewer Service from Existing System: Water from Owner's existing water system is available for use without metering and without payment of use charges.
1. Provide connections and extensions of services as required for construction operations.
- F. Electric Power Service from Existing System: Electric power from Owner's existing system is available for use without metering and without payment of use charges.
1. Provide connections and extensions of services as required for construction operations.

1.3 INFORMATIONAL SUBMITTALS

- A. Site Utilization Plan: Show temporary facilities, temporary utility lines and connections, staging areas, construction site entrances, vehicle circulation, and parking areas for construction personnel.
- B. Implementation and Termination Schedule: Within 15 days of date established for commencement of Work, submit schedule indicating implementation and termination dates of each temporary utility.
- C. Project Identification and Temporary Signs: Show fabrication and installation details, including plans, elevations, details, layouts, typestyles, graphic elements, and message content.
- D. Erosion- and Sedimentation-Control Plan: Show compliance with requirements of 2003 EPA Construction General Permit or authorities having jurisdiction, whichever is more stringent.
- E. Fire-Safety Program: Show compliance with requirements of NFPA 241 and authorities having jurisdiction. Indicate Contractor personnel responsible for management of fire-prevention program.
- F. Moisture and Mold Control Plan: Describe procedures and controls for protecting materials and construction from water absorption and damage and mold. Describe delivery, handling, storage, installation, and protection provisions for materials subject to water absorption or water damage.
1. Indicate procedures for discarding water-damaged materials, protocols for mitigating water intrusion into completed Work, and requirements for replacing water-damaged Work.

2. Indicate sequencing of work that requires water, such as sprayed fire-resistive materials[,] **[plastering]**, **[and] [terrazzo grinding]**, and describe plans for dealing with water from these operations. Show procedures for verifying that wet construction has dried sufficiently to permit installation of finish materials.
 3. Indicate methods to be used to avoid trapping water in finished Work.
- G. Dust- and HVAC-Control Plan: Submit coordination drawing and narrative that indicates dust- and HVAC-control measures proposed for use, proposed locations, and proposed time frame for their operation. Include the following:
1. Locations of dust-control partitions at each phase of Work.
 2. HVAC system isolation schematic drawing.
 3. Location of proposed air-filtration system discharge.
 4. Waste-handling procedures.
 5. Other dust-control measures.
- H. Noise and Vibration Control Plan: Identify construction activities that may impact the occupancy and use of existing spaces within the building or adjacent existing buildings, whether occupied by others, or occupied by the Owner. Include the following:
1. Methods used to meet goals and requirements of Owner.
 2. Concrete cutting method(s) to be used.
 3. Location of construction devices on site.
 4. Show compliance with use and maintenance of quieted construction devices for duration of Project.
 5. Indicate activities that may disturb building occupants and that are planned to be performed during non-standard working hours as coordinated with Owner.
 6. Indicate locations of sensitive areas or other areas requiring special attention as identified by Owner. Indicate means for complying with Owner's requirements.

1.4 QUALITY ASSURANCE

- A. Electric Service: Comply with NECA, NEMA, and UL standards and regulations for temporary electric service. Install service to comply with NFPA 70.
- B. Tests and Inspections: Arrange for authorities having jurisdiction to test and inspect each temporary utility before use. Obtain required certifications and permits.
- C. Accessible Temporary Egress: Comply with current edition of Washington State Building Code, U.S. Architectural & Transportation Barriers Compliance Board's ADA-ABA Accessibility Guidelines, and ICC A117.1.

1.5 PROJECT CONDITIONS

- A. Temporary Use of Permanent Facilities: Engage Installer of each permanent service to assume responsibility for operation, maintenance, and protection of each permanent service during its use as a construction facility before Owner's acceptance, regardless of previously assigned responsibilities.

PART 2 - PRODUCTS

2.1 MATERIALS

- A. General: Provide new materials unless undamaged, previously used materials in serviceable condition are approved by Architect. Provide materials suitable for intended use.

- B. Chain-Link Fencing: Minimum 2 inch, 0.148 inch thick, galvanized-steel, chain-link fabric fencing; minimum 8 feet high with galvanized-steel pipe posts; minimum 2-3/8 inch OD line posts and 2-7/8 inch OD corner and pull posts, with 1-5/8 inch OD top rails.
- C. Portable Chain-Link Fencing: Minimum 2 inch, 0.148 inch thick, galvanized-steel, chain-link fabric fencing; minimum 6 feet high with galvanized-steel pipe posts; minimum 2-3/8 inch OD line posts and 2-7/8 inch OD corner and pull posts, with 1-5/8 inch OD top and bottom rails. Provide concrete or galvanized -steel bases for supporting posts.
 - 1. Where appropriate, equip fencing with vehicular and pedestrian gates with locks.
- D. Fencing Windscreen Privacy Screen: Polyester fabric scrim with grommets for attachment to chain link fence, sized to height of fence, in color selected by Architect from manufacturer's standard colors.
- E. Wood Enclosure Fence: Plywood, 6 feet [8 feet] high, framed with four 2 by 4 inch rails, with preservative-treated wood posts spaced not more than 8 feet apart.
- F. Polyethylene Sheet: Reinforced, fire-resistive sheet, 10 mil minimum thickness, with flame-spread rating of 15 or less per ASTM E84 and passing NFPA 701 Test Method 2.
- G. Dust-Control Adhesive-Surface Walk-Off Mats: Provide mats minimum 36 by 60 inches.
- H. Insulation: Unfaced mineral-fiber blanket, manufactured from glass, slag wool, or rock wool, respectively.
 - 1. Surface Burning Characteristics, ASTM E84:
 - a. Flame Spread Index: 25.
 - b. Smoke Developed Index: 50.
- I. Disposable Supplies: Provide toilet tissue, paper towels, paper cups, and similar disposable materials for each facility, and maintain adequate supply.

2.2 TEMPORARY FACILITIES

- A. Field Offices, General: Prefabricated or mobile units with serviceable finishes, temperature controls, and foundations adequate for normal loading.
 - 1. Size: Minimum 12 by 60 foot or equivalent double wide unit with 12 by 24 foot meeting room.
 - 2. Locate field office a minimum distance of 30 feet from existing and new structures.
- B. Field Offices, General: Owner will provide conditioned interior space for field offices [for duration of Project] [upon completion of demolition and enclosure].
- C. Common-Use Field Office: Of sufficient size to accommodate needs of Owner, Architect, and construction personnel office activities and to accommodate Project meetings specified in other Division 01 Sections. Keep office clean and orderly. Furnish and equip offices as follows:
 - 1. Furniture required for Project-site documents including file cabinets, plan tables, plan racks, and bookcases.
 - 2. Conference room of sufficient size to accommodate meetings of 6 individuals. Provide electrical power service and 120-V ac duplex receptacles, with no fewer than 1 receptacle on each wall. Furnish room with conference table, chairs, drawing rack, drawing display table, and 4-foot-square tack and marker boards.
 - 3. Drinking water and private toilet.
 - 4. Coffee machine and supplies.
 - 5. Heating and cooling equipment necessary to maintain a uniform indoor temperature of 68 to 72 deg F.
 - 6. Lighting fixtures capable of maintaining average illumination of 20 fc at desk height.
- D. Power Distribution System Circuits: Where permitted, overhead and exposed, wiring circuits for surveillance, not exceeding 125-V ac, 20-A rating, and lighting circuits, may be nonmetallic sheathed cable.

1. Electrical Outlets: Properly configured, NEMA-polarized 120-V ac duplex receptacles to prevent insertion of 110- to 120-V plugs into higher-voltage outlets; equipped with ground-fault circuit interrupters, reset button, and pilot light.
 - a. Provide not less than 1 receptacle on each wall.
- E. Storage and Fabrication Sheds: Provide sheds sized, furnished, and equipped to accommodate materials and equipment for construction operations.
 1. Store combustible materials apart from building.

2.3 EQUIPMENT

- A. Fire Extinguishers: Portable, UL rated; with class and extinguishing agent as required by locations and classes of fire exposures.
- B. HVAC Equipment: Unless Owner authorizes use of permanent HVAC system, provide vented, self-contained, liquid-propane-gas or fuel-oil heaters with individual space thermostatic control.
 1. Use of gasoline-burning space heaters, open-flame heaters, or salamander-type heating units is prohibited.
 2. Heating Units: Listed and labeled for type of fuel being consumed, by a qualified testing agency acceptable to authorities having jurisdiction, and marked for intended location and application.
 3. Permanent HVAC System: If Owner authorizes use of permanent HVAC system for temporary use during construction, provide filter with MERV of 8 at each return-air grille in system and remove at end of construction and clean HVAC system as required in Section 017700 – Closeout Procedures.
- C. Air-Filtration Units: Primary and secondary HEPA-filter-equipped portable units with 4-stage filtration. Provide single switch for emergency shutoff. Configure to run continuously.

PART 3 - EXECUTION

3.1 TEMPORARY FACILITIES, GENERAL

- A. Conservation: Coordinate construction and use of temporary facilities with consideration given to conservation of energy, water, and materials. Coordinate use of temporary utilities to minimize waste.
 1. Salvage materials and equipment involved in performance of, but not actually incorporated into, Work. See other Sections for disposition of salvaged materials that are designated as Owner's property.

3.2 INSTALLATION, GENERAL

- A. Locate facilities where they will serve Project adequately and result in minimum interference with performance of Work. Relocate and modify facilities as required by progress of Work.
 1. Locate facilities to limit site disturbance as specified in Section 011100 – Summary of Work.
- B. Provide each facility ready for use when needed to avoid delay. Do not remove until facilities are no longer needed or are replaced by authorized use of completed permanent facilities.
- C. Isolation of Work Areas in Occupied Facilities: Prevent dust, fumes, and odors from entering occupied areas.
 1. Prior to commencing Work, isolate HVAC system in areas where Work is to be performed.
 - a. Disconnect supply and return ductwork in Work area from HVAC systems servicing occupied areas.
 - b. Maintain negative air pressure within Work area using HEPA-equipped air-filtration units, starting with commencement of temporary partition construction, and continuing until removal of temporary partitions is complete.

2. Maintain dust partitions during Work. Use vacuum collection attachments on dust-producing equipment. Isolate limited Work within occupied areas using portable dust-containment devices.
3. Perform daily construction cleanup and final cleanup using approved, HEPA-filter-equipped vacuum equipment.

3.3 TEMPORARY UTILITY INSTALLATION

- A. General: Install temporary service or connect to existing service.
 1. Arrange with utility company, Owner, and existing users for time when service can be interrupted, if necessary, to make connections for temporary services.
- B. Sewers and Drainage: Provide temporary utilities to lawfully remove effluent.
 1. Connect temporary sewers to **[municipal system]** **[private system indicated]** as directed by authorities having jurisdiction.
- C. Water Service: Install water service and distribution piping in sizes and pressures adequate for construction.
- D. **[Water Service: Connect to Owner's existing water service facilities. Clean and maintain water service facilities in a condition acceptable to Owner. At Substantial Completion, restore these facilities to condition existing before initial use.]**
 1. **[Use trigger-operated nozzles for water hoses to avoid waste of water.]**
- E. Sanitary Facilities: Provide temporary toilets, wash facilities, safety shower and eyewash facilities, and drinking water for use of construction personnel. Comply with requirements of authorities having jurisdiction for type, number, location, operation, and maintenance of fixtures and facilities.
 1. Use of Permanent Toilets: Use of Owner's **[existing and]** new toilet facilities **[is not permitted]** **[will be permitted, as long as facilities are cleaned and maintained in a condition acceptable to Owner. At Substantial Completion, restore these facilities to condition existing before initial use.]**
- F. Temporary Heating and Cooling: Provide temporary heating and cooling required by construction activities for curing or drying of completed installations or for protecting installed construction from adverse effects of low temperatures or high humidity. Select equipment that will not have a harmful effect on completed installations or elements being installed.
 1. Maintain a minimum temperature of 50 deg F in permanently enclosed portions of building for normal construction activities, and 65 deg F for finishing activities and areas where finished Work has been installed
 2. Provide temporary dehumidification systems when required to reduce ambient and substrate moisture levels to level required to allow installation or application of finishes and their proper curing or drying.
- G. Electric Power Service: Connect to Owner's existing electric power service. Maintain equipment in a condition acceptable to Owner.
- H. Electric Power Service: Provide weatherproof, grounded, electric power service and distribution system of sufficient size, capacity, and power characteristics required for construction operations.
 1. Include meters, transformers, overload-protected disconnecting means, automatic ground-fault interrupters, and main distribution switchgear.
 2. Install electric power service underground unless overhead service is required.
 - a. If overhead service is unavoidable, install power distribution wiring overhead and rise vertically where least exposed to damage.
- I. Lighting: Provide temporary lighting with local switching that provides adequate illumination for construction operations, observations, inspections, and traffic conditions.

1. Install and operate temporary lighting that fulfills security and protection requirements without operating entire system.
 - a. Minimum Temporary Lighting: Not less than one 200 watt incandescent lamp for each 900 sq. ft. of area (not less than 1 bulb per room) or as directed.
 2. Install exterior-yard site lighting that provides adequate illumination for construction operations, traffic conditions, and signage visibility when Work is being performed.
 3. Install lighting for Project identification sign.
- J. Telephone Service: Provide temporary telephone service in common-use facilities for use by all construction personnel. Install Wi-Fi cell phone access equipment and 1 land-based telephone lines for each field office.
- K. Cellular Telephone Service: Install Wi-Fi cell phone access equipment and 1 land-based telephone lines for each field office
1. At each telephone, post a list of important telephone numbers.
 - a. Police and fire departments.
 - b. Ambulance service.
 - c. Contractor's home office.
 - d. Contractor's emergency after-hours telephone number.
 - e. Architect's office.
 - f. Engineers' offices.
 - g. Owner's office.
 - h. Principal subcontractors' field and home offices.
- L. Electronic Communication Service: Provide secure WiFi wireless connection to internet with provisions for access by Architect and Owner.
- M. Electronic Communication Service: Provide wireless connectivity in primary field office adequate for use by Architect, Owner, and Project team's wireless devices to access Project electronic documents and maintain electronic communications.

3.4 SUPPORT FACILITIES INSTALLATION

- A. Comply with the following:
1. Provide construction for temporary offices, shops, and sheds located within construction area or within 30 feet of building lines that is noncombustible according to ASTM E136. Comply with NFPA 241.
 2. Maintain support facilities until Architect schedules Substantial Completion inspection. Remove prior to Substantial Completion. Personnel remaining after Substantial Completion will be permitted to use permanent facilities, under conditions acceptable to Owner.
 3. Protect streets connecting to Project from deposits of mud, sand, stone, litter, or debris of any form. Clean mud collected on vehicle wheels prior to leaving construction area. Immediately remove mud or debris collecting on streets from Project activities before becoming a traffic hazard or being carried into surrounding buildings.
 4. Promptly remove soil and debris from paved areas. Clean wheels of vehicles before leaving site to avoid tracking soil onto roads, walks, or other paved areas.
 5. Inspect construction site vehicle exit locations for evidence of off-site sediment tracking onto paved surfaces. Remove tracked sediment off-site paved surfaces within 24 hours of discovery.
- B. **Temporary Roads** and Paved Areas: Construct and maintain temporary roads and paved areas adequate for construction operations. Locate temporary roads and paved areas within construction limits indicated on Drawings.
1. Provide dust-control treatment that is nonpolluting and nontracking. Reapply treatment as required to minimize dust.

- C. **Temporary Use** of Planned Permanent Roads and Paved Areas: Locate temporary roads and paved areas in same location as permanent roads and paved areas. Construct and maintain temporary roads and paved areas adequate for construction operations. Extend temporary roads and paved areas, within construction limits indicated, as necessary for construction operations.
1. Coordinate elevations of temporary roads and paved areas with permanent roads and paved areas.
 2. Prepare subgrade and install subbase and base for temporary roads and paved areas according to **[Division 31 Section for Earth Moving]** Section 312000 – Earth Moving.
 3. Provide dust-control treatment that is nonpolluting and non-tracking. Reapply treatment as required to minimize dust.
 4. Recondition base after temporary use, including removing contaminated material, regrading, proof-rolling, compacting, and testing.
 5. Delay installation of final course of permanent hot-mix asphalt pavement until immediately before Substantial Completion. Repair hot-mix asphalt base-course pavement before installation of final course according to **[Division 31 Section for Asphalt Paving]** Section 321216 – Asphalt Paving.
- D. Traffic Controls: Comply with requirements of authorities having jurisdiction.
1. Protect existing site improvements to remain including curbs, pavement, and utilities.
 2. Maintain access for fire-fighting equipment and access to fire hydrants.
- E. Parking: **[Provide temporary offsite]** Use designated areas of Owner's existing parking areas for construction personnel.
- F. Dewatering Facilities and Drains: Comply with requirements of authorities having jurisdiction. Maintain Project site, excavations, and construction free of water.
1. Dispose of rainwater in a lawful manner that will not result in flooding Project or adjoining properties or endanger permanent Work or temporary facilities.
 2. Remove snow and ice as required to minimize accumulations.
- G. Project Signs: Provide Project signs as indicated. Unauthorized signs are not permitted.
1. Identification Signs: Provide Project identification signs as indicated on Drawings, or if not indicated, as approved by Owner.
 2. Temporary Signs: Provide other signs as indicated and as required to inform public and individuals seeking entrance to Project.
 - a. Provide temporary, directional signs for construction personnel and visitors.
 3. Maintain and touch up signs so they are legible at all times.
- H. Waste Disposal Facilities: Comply with requirements specified in Section 017419 – Construction Waste Management and Disposal.
- I. Waste Disposal Facilities: Provide waste-collection containers in sizes adequate to handle waste from construction operations. Comply with requirements of authorities having jurisdiction. Comply with progress cleaning requirements in Section 017300 – Execution.
- J. Lifts and Hoists: Provide facilities necessary for hoisting materials and personnel.
1. Truck cranes and similar devices used for hoisting materials are considered "tools and equipment" and not temporary facilities.
- K. Temporary Elevator Use: Temporary use of elevators is not permitted unless specifically approved in writing by Architect. If Architect approves temporary use of elevators, comply with Protection Article in **[Section 142400 – Hydraulic Elevators]**.
1. Do not load elevators beyond their rated weight capacity.
 2. Provide protective coverings, barriers, devices, signs, or other procedures to protect elevator car and entrance doors and frame. If, despite such protection, elevators become damaged, engage elevator Installer to restore damaged work so no evidence remains of correction Work.

Return items that cannot be refinished in field to the shop, make required repairs and refinish entire unit, or provide new units as required.

- L. Temporary Stairs: Until permanent stairs are available, provide temporary stairs where ladders are not adequate.
- M. Temporary Use of Permanent Stairs: Use of new stairs for construction traffic will be permitted, provided stairs are protected and finishes restored to new condition at time of Substantial Completion.

3.5 SECURITY AND PROTECTION FACILITIES INSTALLATION

- A. Protection of Existing Facilities: Protect existing vegetation, equipment, structures, utilities, and other improvements at Project site and on adjacent properties, except those indicated to be removed or altered. Repair damage to existing facilities.
 - 1. Where access to adjacent properties is required in order to affect protection of existing facilities, obtain written permission from adjacent property owner to access property for that purpose.
- B. Environmental Protection: Provide protection, operate temporary facilities, and conduct construction as required to comply with environmental regulations and that minimize possible air, waterway, and subsoil contamination or pollution or other undesirable effects.
 - 1. Comply with Work restrictions specified in Section 011100 – Summary of Work.
- C. Temporary Erosion and Sedimentation Control: Comply with requirements of EPA Construction General Permit or authorities having jurisdiction, whichever is more stringent and requirements specified in **[Division 31 Section for Site Clearing]** Section 311000 – Site Clearing.
- D. Temporary Erosion and Sedimentation Control: Provide measures to prevent soil erosion and discharge of soil-bearing water runoff and airborne dust to undisturbed areas and to adjacent properties and walkways, according to erosion- and sedimentation-control Drawings or requirements of EPA Construction General Permit or authorities having jurisdiction, whichever is more stringent.
 - 1. Verify that flows of water redirected from construction areas or generated by construction activity do not enter or cross tree- or plant-protection zones.
 - 2. Inspect, repair, and maintain erosion- and sedimentation-control measures during construction until permanent vegetation has been established.
 - 3. Clean, repair, and restore adjoining properties and roads affected by erosion and sedimentation from Project site during the course of Project.
 - 4. Remove erosion and sedimentation controls and restore and stabilize areas disturbed during removal.
- E. Stormwater Control: Comply with requirements of authorities having jurisdiction. Provide barriers in and around excavations and subgrade construction to prevent flooding by runoff of stormwater from heavy rains.
- F. Tree and Plant Protection: Comply with requirements specified in Section 015639 – Temporary Tree and Plant Protection.
- G. Pest Control: Engage pest-control service to recommend practices to minimize attraction and harboring of rodents, roaches, and other pests and to perform extermination and control procedures at **[regular]** **[weekly]** intervals so Project will be free of pests and their residues at Substantial Completion. Perform control operations lawfully, using materials approved by authorities having jurisdiction.
- H. Site Enclosure Fence: **[Before construction operations begin]** **[Prior to commencing earthwork]**, provide site enclosure fence in a manner that will prevent people from easily entering site except by entrance gates.

1. Extent of Fence: As required to enclose entire Project site or portion determined sufficient to accommodate construction operations or as indicated on Drawings.
 2. Provide lockable gates in sizes and at locations necessary to accommodate delivery vehicles and other construction operations. Lock entrances at end of each work day.
 3. Maintain security by limiting number of keys and restricting distribution to authorized personnel. **[Furnish 1 set of keys to Owner.]**
- I. Security Enclosure and Lockup: Install temporary enclosure around partially completed areas of construction. Provide lockable entrances to prevent unauthorized entrance, vandalism, theft, and similar violations of security. Lock entrances at end of each workday.
- J. Barricades, Warning Signs, and Lights: Comply with requirements of authorities having jurisdiction for erecting structurally adequate barricades, including warning signs and lighting.
- K. Covered Walkway: When necessary, erect protective, covered walkway for passage of individuals through or adjacent to Project site. Coordinate with entrance gates, other facilities, and obstructions. Comply with regulations of authorities having jurisdiction and requirements indicated on Drawings.
1. Provide overhead decking, protective enclosure walls, handrails, barricades, warning signs, exit signs, lights, safe and well-drained walkways, and similar provisions for protection and safe passage.
 2. Paint and maintain appearance of walkway for duration of Work.
- L. Temporary Enclosures: Provide temporary enclosures for protection of construction, in progress and completed, from exposure, foul weather, other construction operations, and similar activities. Provide temporary weathertight enclosure for building exterior.
1. Where heating or cooling is needed and permanent enclosure is incomplete, insulate temporary enclosures.
- M. Temporary Partitions: Provide floor-to-ceiling dustproof partitions to limit dust and dirt migration and to separate areas occupied by from fumes and noise.
1. Construct dustproof partitions with gypsum wallboard with joints taped on occupied side, and fire-retardant-treated plywood on construction operations side.
 2. Where fire-resistance-rated temporary partitions are indicated or are required by authorities having jurisdiction, construct partitions according to rated assemblies.
 3. Seal joints and perimeter. Equip partitions with gasketed dustproof doors and security locks where openings are required.
 4. Protect air-handling equipment.
 5. Provide walk-off mats at each entrance through temporary partition.
- N. Temporary Fire Protection: Install and maintain temporary fire-protection facilities of types needed to protect against reasonably predictable and controllable fire losses. Comply with NFPA 241; manage fire-prevention program.
1. Prohibit smoking in construction areas. Comply with additional limits on smoking specified in other Sections.
 2. Supervise welding operations, combustion-type temporary heating units, and similar sources of fire ignition according to requirements of authorities having jurisdiction.
 3. Develop and supervise an overall fire-prevention and -protection program for personnel at Project site. Review needs with local fire department and establish procedures to be followed. Instruct personnel in methods and procedures. Post warnings and information.
 4. Provide temporary standpipes and hoses for fire protection. Hang hoses with a warning sign stating that hoses are for fire-protection purposes only and are not to be removed. Match hose size with outlet size and equip with suitable nozzles.

3.6 MOISTURE AND MOLD CONTROL

- A. Comply with recommendations contained in Associated General Contractors (AGC) document "Managing the Risk of Mold in the Construction of Buildings." Prepare and submit moisture-protection plan for protecting materials from water damage as indicated below.
- B. Moisture and Mold Protection: Protect stored materials and installed Work in accordance with Moisture and Mold Protection Plan.
- C. Exposed Construction Period: Before installation of weather barriers, when materials are subject to wetting and exposure and to airborne mold spores, protect as follows:
 - 1. Protect porous materials from water damage.
 - 2. Protect stored and installed material from flowing or standing water.
 - 3. Keep porous and organic materials from coming into prolonged contact with concrete.
 - 4. Remove standing water from decks.
 - 5. Keep deck openings covered or dammed.
- D. Partially Enclosed Construction Period: After installation of weather barriers but before full enclosure and conditioning of building, when installed materials are still subject to infiltration of moisture and ambient mold spores, protect as follows:
 - 1. Do not load or install drywall or other porous materials or components, or items with high organic content, into partially enclosed building.
 - 2. Keep interior spaces reasonably clean and protected from water damage.
 - 3. Periodically collect and remove waste containing cellulose or other organic matter.
 - 4. Discard or replace water-damaged material.
 - 5. Do not install material that is wet.
 - 6. Discard and replace stored or installed material that begins to grow mold.
 - 7. Perform work in a sequence that allows wet materials adequate time to dry before enclosing the material in gypsum board or other interior finishes.
- E. Controlled Construction Period: After completing and sealing of building enclosure, but prior to full operation of permanent HVAC systems, maintain as follows:
 - 1. Control moisture and humidity inside building by maintaining effective dry-in conditions.
 - 2. Use temporary or permanent HVAC system to control humidity within ranges specified for installed and stored materials.
 - 3. Comply with manufacturer's written instructions for temperature, relative humidity, and exposure to water limits.
 - a. Hygroscopic materials that may support mold growth, including wood and gypsum-based products, that become wet during the course of construction and remain wet for 48 hours are considered defective and require replacing.
 - b. Measure moisture content of materials that have been exposed to moisture during construction operations or after installation. Record readings beginning at time of exposure and continuing daily for 48 hours. Identify materials containing moisture levels higher than allowed. Report findings in writing to Architect.
 - c. Remove materials that cannot be completely restored to their manufactured moisture level within 48 hours and replace with new materials.

3.7 OPERATION, TERMINATION, AND REMOVAL

- A. Supervision: Enforce strict discipline in use of temporary facilities. To minimize waste and abuse, limit availability of temporary facilities to essential and intended uses.
- B. Maintenance: Maintain facilities in good operating condition until removal.
 - 1. Maintain operation of temporary enclosures, heating, cooling, humidity control, ventilation, and similar facilities on a 24-hour basis where required to achieve indicated results and to avoid possibility of damage.

- C. Temporary Facility Changeover: Do not change over from using temporary security and protection facilities to permanent facilities until Substantial Completion.
- D. Termination and Removal: Remove each temporary facility when need for its service has ended, when it has been replaced by authorized use of a permanent facility, or no later than Substantial Completion. Complete or, if necessary, restore permanent construction that may have been delayed because of interference with temporary facility. Repair damaged Work, clean exposed surfaces, and replace construction that cannot be satisfactorily repaired.
 - 1. Materials and facilities that constitute temporary facilities are property of Contractor. Owner reserves right to take possession of Project identification signs.
 - 2. Remove temporary roads and paved areas not intended for or acceptable for integration into permanent construction. Where area is intended for landscape development, remove soil and aggregate fill that do not comply with requirements for fill or subsoil. Remove materials contaminated with road oil, asphalt and other petrochemical compounds, and other substances that might impair growth of plant materials or lawns. Repair or replace street paving, curbs, and sidewalks at temporary entrances, as required by authorities having jurisdiction.
 - 3. At Substantial Completion, repair, renovate, and clean permanent facilities used during construction period. Comply with final cleaning requirements specified in Section 017700 – Closeout Procedures.

END OF SECTION 015000

SECTION 016000
PRODUCT REQUIREMENTS

PART 1 - GENERAL

1.1 SUMMARY

A. Section Includes:

1. Administrative and procedural requirements for selection of products for use in Project; product delivery, storage, and handling; manufacturers' standard warranties on products; special warranties; and comparable products.

1.2 DEFINITIONS

A. Products: Items obtained for incorporating into Work, whether purchased for Project or taken from previously purchased stock. The term "product" includes the terms "material," "equipment," "system," and terms of similar intent.

1. Named Products: Items identified by manufacturer's product name, including make or model number or other designation shown or listed in manufacturer's published product literature that is current as of date of the Contract Documents.
2. New Products: Items that have not previously been incorporated into another project or facility. Salvaged items or items reused from other projects are not considered new products. Items that are manufactured or fabricated to include recycled content materials are considered new products, unless indicated otherwise.
3. Comparable Product: Product by named manufacturer that is demonstrated and approved through comparable product submittal process described in Part 2 Comparable Products Article, to have indicated qualities related to type, function, dimension, in-service performance, physical properties, appearance, and other characteristics that equal or exceed those of specified product.

B. Basis-of-Design Product Specification: A specification in which a single manufacturer's product is named and accompanied by the words "Basis-Of-Design Product," including make or model number or other designation. Published attributes and characteristics of basis-of-design product establish salient characteristics of products.

1. Evaluation of Comparable Products: In addition to basis-of-design product description, product attributes and characteristics may be listed to establish significant qualities related to type, function, in-service performance and physical properties, weight, dimension, durability, visual characteristics, and other special features and requirements for purposes of evaluating comparable products of additional manufacturers named in Specifications. Manufacturer's published attributes and characteristics of basis-of-design product also establish salient characteristics of products for purposes of evaluating comparable products.

C. Subject to Compliance with Requirements: Where the phrase "Subject to compliance with requirements" introduces a product selection procedure in individual Specification Sections, provide products qualified under specified product procedure. In the event that a named product or product by a named manufacturer does not meet other requirements of Specifications, select another named product or product from another named manufacturer that does meet requirements of Specifications; submit a comparable product request or substitution request, if applicable.

D. Comparable Product Request Submittal: An action submittal requesting consideration of a comparable product, including the following information:

1. Identification of basis-of-design product or fabrication or installation method to be replaced, including Specification Section number and title and Drawing numbers and titles.

2. Data indicating compliance with the requirements specified in Part 2 "Comparable Products" Article.

E. Basis-of-Design Product Specification Submittal: An action submittal complying with requirements in Section 013300 – Submittal Procedures indicating compliance with requirements.

F. Substitution: Refer to Section 012500 – Substitution Procedures for definition and limitations on substitutions.

1.3 HUD REQUIREMENTS

A. Comply with Use of Materials Bulletins for Carpet, Wood Doors, Sealed insulating glass units and windows. Reference documents can be found at:

https://www.hud.gov/program_offices/administration/hudclips/bulletins/umbs

1.4 QUALITY ASSURANCE

A. Compatibility of Options: If Contractor is given option of selecting between 2 or more products for use on Project, select product compatible with products previously selected, even if previously selected products were also options.

B. Identification of Products: Except for required labels and operating data, do not attach or imprint manufacturer or product names or trademarks on exposed surfaces of products or equipment that will be exposed to view in occupied spaces or on exterior.

1. Labels: Locate required product labels and stamps on a concealed surface, or, where required for observation following installation, on a visually accessible surface that is not conspicuous.

2. Equipment Nameplates: Provide a permanent nameplate on each item of service-connected or power-operated equipment. Locate on a visually accessible but inconspicuous surface. Include information essential for operation, including the following:

- a. Name of product and manufacturer.
- b. Model and serial number.
- c. Capacity.
- d. Speed.
- e. Ratings.

3. See individual identification Sections in Divisions 21, 22, 23, and 26 for additional identification requirements.

1.5 PRODUCT DELIVERY, STORAGE, AND HANDLING

A. General: Deliver, store, and handle products using means and methods that will prevent damage, deterioration, and loss, including theft and vandalism. Comply with manufacturer's written instructions.

B. Delivery and Handling:

1. Schedule delivery to minimize long-term storage at Project site and to prevent overcrowding of construction spaces.

2. Coordinate delivery with installation time to ensure minimum holding time for items that are flammable, hazardous, easily damaged, or sensitive to deterioration, theft, and other losses.

3. Deliver products to Project site in an undamaged condition in manufacturer's original sealed container or other packaging system, complete with labels and instructions for handling, storing, unpacking, protecting, and installing.

4. Inspect products on delivery to determine compliance with the Contract Documents and to determine that products are undamaged and properly protected.

- C. Storage:
1. Store products to allow for inspection and measurement of quantity or counting of units.
 2. Store materials in a manner that will not endanger Project structure.
 3. Store products that are subject to damage by the elements, under cover in a weathertight enclosure above ground, with ventilation adequate to prevent condensation.
 4. Protect foam plastic from exposure to sunlight, except to extent necessary for period of installation and concealment.
 5. Comply with product manufacturer's written instructions for temperature, humidity, ventilation, and weather-protection requirements for storage.
 6. Protect stored products from damage and liquids from freezing.
 7. Provide a secure location and enclosure at Project site for storage of materials and equipment by Owner's construction forces. Coordinate location with Owner.

1.6 PRODUCT WARRANTIES

- A. Warranties specified in other Sections shall be in addition to, and run concurrent with, other warranties required by the Contract Documents. Manufacturer's disclaimers and limitations on product warranties do not relieve Contractor of obligations under requirements of Contract Documents.
1. Manufacturer's Warranty: Written warranty furnished by individual manufacturer for a particular product and specifically endorsed by manufacturer to Owner.
 2. Special Warranty: Written warranty required by Contract Documents to provide specific rights for Owner.
- B. Special Warranties: Prepare written document that contains appropriate terms and identification, ready for execution.
1. Manufacturer's Standard Form: Modified to include Project-specific information and properly executed.
 2. Specified Form: When specified forms are included with Specifications, prepare written document using indicated form properly executed.
 3. See other Sections for specific content requirements and particular requirements for submitting special warranties.
- C. Submittal Time: Comply with requirements in Section 017700 – Closeout Procedures.

PART 2 - PRODUCTS

2.1 PRODUCT SELECTION PROCEDURES

- A. Buy American Act: In compliance with the buy American Act (BAA - [41 U.S.C. § 10a–10d](#)) passed in 1933, and as excepted in [25.202](#), use only domestic construction materials in construction contracts performed in the United States for the following materials:
1. Steel.
- B. General Product Requirements: Provide products that comply with Contract Documents, are undamaged and, unless otherwise indicated, are new at time of installation.
1. Provide products complete with accessories, trim, finish, fasteners, and other items needed for a complete installation and indicated use and effect.
 2. Standard Products: If available, and unless custom products or nonstandard options are specified, provide standard products of types that have been produced and used successfully in similar situations on other projects.
 3. Owner reserves the right to limit selection to products with warranties meeting requirements of Contract Documents.
 4. Where products are accompanied by the term "as selected," Architect will make selection.

5. Descriptive, performance, and reference standard requirements in the Specifications establish salient characteristics of products.
 6. Or Equal: For products specified by name and accompanied by the term "or equal," or "or approved equal," or " approved substitution," comply with requirements in "Comparable Products" Article to obtain approval for use of an unnamed product.
 - a. Submit additional documentation required by Architect in order to establish equivalency of proposed products. Evaluation of "or equal" product status is by Architect; whose determination is final.
 - b. The term "or equal" is not used in these Specifications.
- C. Salient Characteristics: Where reference to salient characteristics is indicated in individual Specification Sections, Drawings and Specifications are based on proprietary literature from manufacturers' specified materials and products. Materials and products were selected based on specified manufacturers' colors and patterns, performance requirements, or other attributes that are considered among salient characteristics of specified materials and products. Other manufacturers shall comply with the following requirements in order to be considered for substitution.
1. Provide products in full compliance with materials, colors, textures, patterns, performance requirements, and other features indicated.
 2. Products are submitted to Architect for review and consideration for written prior approval.
 3. Understand that materials, colors, textures, patterns, performance requirements, and other features indicated have been selected to establish a cohesive design element or specific performance requirement of Project, therefore Architect is sole judge of compliance of substitutions with specified salient characteristics.
 4. Acceptance of substitutions is solely at discretion of Architect.
- D. Product Selection Procedures:
1. Sole Product: Where Specifications name a single manufacturer and product, provide named product that complies with requirements. Comparable products or substitutions for Contractor's convenience will not be considered.
 - a. Sole product may be indicated by the phrase: "Subject to compliance with requirements, provide the following: ..."
 2. Sole Manufacturer/Source: Where Specifications name a single manufacturer or source, provide a product by named manufacturer or source that complies with requirements. Comparable products or substitutions for Contractor's convenience will not be considered.
 - a. Sole manufacturer/source may be indicated by the phrase: "Subject to compliance with requirements, provide products by the following: ..."
 3. Limited List of Products: Where Specifications include a list of names of both manufacturers and products, provide 1 of the products listed that complies with requirements. Comparable products or substitutions for Contractor's convenience will not be considered unless otherwise indicated.
 - a. Limited list of products may be indicated by the phrase: "Subject to compliance with requirements, provide one of the following:"
 4. Non-Limited List of Products: Where Specifications include a list of names of both available manufacturers and products, provide 1 of the products listed, or an unnamed product, which complies with requirements.
 - a. Non-limited list of products is indicated by the phrase: "Subject to compliance with requirements, available products that may be incorporated in Work include the following:"
 5. Limited List of Manufacturers: Where Specifications include a list of manufacturers' names, provide a product by 1 of the manufacturers listed that complies with requirements. Comparable products or substitutions for Contractor's convenience will not be considered unless otherwise indicated.
 - a. Limited list of manufacturers is indicated by the phrase: "Subject to compliance with requirements, provide products by one of the following:"

6. Non-Limited List of Manufacturers: Where Specifications include a list of available manufacturers, provide a product by 1 of the manufacturers listed, or a product by an unnamed manufacturer, which complies with requirements.
 - a. Non-limited list of manufacturers is indicated by the phrase: "Subject to compliance with requirements, available manufacturers whose products may be incorporated in the Work include the following:"
7. Basis-of-Design Product: Where Specifications name a product, or refer to a product indicated on Drawings, and include a list of manufacturers, provide specified or indicated product or a comparable product by one of the other named manufacturers. Drawings and Specifications indicate sizes, profiles, dimensions, and other characteristics that are based on product named. Comply with requirements in "Comparable Products" Article for consideration of an unnamed product by 1 of the other named manufacturers.
 - a. For approval of products by unnamed manufacturers, comply with requirements in Section 012500 – Substitution Procedures for substitutions for convenience.
- E. Visual Matching Specification: Where Specifications require "match Architect's sample," provide a product that complies with requirements and matches Architect's sample. Architect's decision will be final on whether a proposed product matches.
 1. If no product available within specified category matches and complies with other specified requirements, comply with requirements in Section 012500 – Substitution Procedures for proposal of product.
- F. Visual Selection Specification: Where Specifications include the phrase "as selected by Architect from manufacturer's full range" or a similar phrase, select a product that complies with requirements. Architect will select color, gloss, pattern, density, or texture from manufacturer's product line that includes both standard and premium items.
- G. Visual Selection Specification: Where Specifications include one of the following phrases, select a product that complies with other specified requirements.
 1. Standard Range: Where Specifications include the phrase " as selected by Architect from manufacturer's standard range" or similar phrase, Architect will select color, gloss, pattern, density, or texture from manufacturer's product line that does not include premium items.
 2. Full Range: Where Specifications include the phrase " as selected by Architect from manufacturer's full range" or similar phrase, Architect will select color, gloss, pattern, density, or texture from manufacturer's product line that includes both standard and premium items.
- H. Sustainable Product Selection: Where Specifications require product to meet sustainable product characteristics, select products complying with indicated requirements. Comply with requirements in Division 01 sustainability requirements Section and individual Specification Sections.
 1. Select products for which sustainable design documentation submittals are available from manufacturer.

2.2 COMPARABLE PRODUCTS

- A. Conditions for Consideration of Comparable Products: Architect will consider Contractor's request for comparable product when the following conditions are satisfied. If the following conditions are not satisfied, Architect may return requests without action, except to record noncompliance with these requirements:
 1. Evidence that proposed product does not require revisions to Contract Documents, is consistent with Contract Documents, will produce indicated results, and is compatible with other portions of Work.
 2. Detailed comparison of significant qualities of proposed product with those named in Specifications. Significant product qualities include attributes such as type, function, in-service performance and physical properties, weight, dimension, durability, visual characteristics, and other specific features and requirements.
 3. Evidence that proposed product provides specified warranty.

4. List of similar installations for completed projects with project names and addresses and names and addresses of architects and owners, if requested.
 5. Samples, if requested.
- B. Architect's Action on Comparable Products Submittal: If necessary, Architect will request additional information or documentation for evaluation, as specified in Section 013300 – Submittal Procedures.
1. Form of Approval of Submittal: As specified in Section 013300 – Submittal Procedures.
 2. Use product specified if Architect does not issue a decision on use of a comparable product request within time allocated.
- C. Submittal Requirements: Approval by Architect of Contractor's request for use of comparable product is not intended to satisfy other submittal requirements. Comply with specified submittal requirements.

PART 3 - EXECUTION (NOT USED)

END OF SECTION 016000

SECTION 017300
EXECUTION

PART 1 - GENERAL

1.1 SUMMARY

- A. Section includes general administrative and procedural requirements governing execution of Work including the following:
 - 1. Construction layout.
 - 2. Field engineering and surveying.
 - 3. Installation of Work.
 - 4. Coordination of Owner-installed products.
 - 5. Progress cleaning.
 - 6. Starting and adjusting.
 - 7. Protection of installed construction.

1.2 INFORMATIONAL SUBMITTALS

- A. Qualification Data: For land surveyor.
- B. Certificates: Submit certificate signed by land surveyor certifying that location and elevation of improvements comply with requirements.
- C. Landfill Receipts: Submit copy of receipts issued by a landfill facility, licensed to accept hazardous materials, for hazardous waste disposal.
- D. Certified Surveys: Submit 2 copies signed by land surveyor.
- E. Final Property Survey: Submit 10 copies showing Work performed and record survey data.

1.3 QUALITY ASSURANCE

- A. Land Surveyor Qualifications: A professional land surveyor who is legally qualified to practice in jurisdiction where Project is located and who is experienced in providing land-surveying services of the kind indicated.
- B. Professional Engineer Qualifications: Refer to Section 014000 – Quality Requirements.
- C. Manufacturer's Installation Instructions: Obtain and maintain on-site manufacturer's written recommendations and instructions for installation of products and equipment.

PART 2 - PRODUCTS

2.1 MATERIALS

- A. Comply with requirements specified in other Sections.
 - 1. To comply with sustainable design and construction practices and procedures, use products for patching that comply with sustainable design requirements.
- B. In-Place Materials: Use materials for patching identical to in-place materials. For exposed surfaces, use materials that visually match in-place adjacent surfaces to fullest extent possible.
 - 1. If identical materials are unavailable or cannot be used, use materials that, when installed, will provide a match acceptable to Architect for visual and functional performance of in-place materials.

- C. Cleaning Agents: Use cleaning materials and agents recommended by manufacturer or fabricator of surface to be cleaned. Do not use cleaning agents that are potentially hazardous to health or property or that might damage finished surfaces.
 - 1. Use cleaning products that comply with Green Seal's GS-37, or if GS-37 is not applicable, use products that comply with California Code of Regulations maximum allowable VOC levels.

PART 3 - EXECUTION

3.1 EXAMINATION

- A. Examination and Acceptance of Conditions: Before proceeding with each component of Work, examine substrates, areas, and conditions, with Installer or Applicator present where indicated, for compliance with requirements for installation tolerances and other conditions affecting performance. Record observations.
 - 1. Examine roughing-in for mechanical and electrical systems to verify actual locations of connections before equipment and fixture installation.
 - 2. Examine walls, floors, and roofs for suitable conditions where products and systems are to be installed.
 - 3. Verify compatibility with and suitability of substrates, including compatibility with existing finishes or primers.
- B. Written Report: Where a written report listing conditions detrimental to performance of Work is required by other Sections, include the following:
 - 1. Description of Work.
 - 2. List of detrimental conditions, including substrates.
 - 3. List of unacceptable installation tolerances.
 - 4. Recommended corrections.
- C. Proceed with installation only after unsatisfactory conditions have been corrected. Proceeding with Work indicates acceptance of surfaces and conditions.

3.2 PREPARATION

- A. Existing Utility Information: Furnish information to local utility and Owner that is necessary to adjust, move, or relocate existing utility structures, utility poles, lines, services, or other utility appurtenances located in or affected by construction. Coordinate with authorities having jurisdiction.
- B. Field Measurements: Take field measurements as required to fit Work properly. Recheck measurements before installing each product. Where portions of Work are indicated to fit to other construction, verify dimensions of other construction by field measurements before fabrication. Coordinate fabrication schedule with construction progress to avoid delaying Work.
- C. Space Requirements: Verify space requirements and dimensions of items shown diagrammatically on Drawings.
- D. Review of Contract Documents and Field Conditions: Immediately on discovery of the need for clarification of Contract Documents caused by differing field conditions outside control of Contractor, submit a request for information to Architect according to requirements in Section 013100 – Project Management and Coordination.

3.3 CONSTRUCTION LAYOUT

- A. Verification: Before proceeding to lay out Work, verify layout information shown on Drawings, in relation to property survey and existing benchmarks. If discrepancies are discovered, promptly notify Architect.

- B. General: Engage a land surveyor to lay out Work using accepted surveying practices.
 - 1. Establish benchmarks and control points to set lines and levels at each story of construction and elsewhere as needed to locate each element of Project.
 - 2. Establish limits on use of Project site.
 - 3. Establish dimensions within tolerances indicated. Do not scale Drawings to obtain required dimensions.
 - 4. Inform installers of lines and levels to which they must comply.
 - 5. Check location, level and plumb, of every major element as Work progresses.
 - 6. Notify Architect when deviations from required lines and levels exceed allowable tolerances.
 - 7. Close site surveys with an error of closure equal to or less than standard established by authorities having jurisdiction.
- C. Site Improvements: Locate and lay out site improvements, including pavements, grading, fill and topsoil placement, utility slopes, and rim and invert elevations.
- D. Building Lines and Levels: Locate and lay out control lines and levels for structures, building foundations, column grids, and floor levels, including those required for mechanical and electrical Work. Transfer survey markings and elevations for use with control lines and levels. Level foundations and piers from 2 or more locations.
- E. Record Log: Maintain a log of layout control Work. Record deviations from required lines and levels. Include beginning and ending dates and times of surveys, weather conditions, name and duty of each survey party member, and types of instruments and tapes used. Make log available for reference by Architect.

3.4 FIELD ENGINEERING

- A. Identification: Owner will identify existing benchmarks, control points, and property corners.
- B. Reference Points: Locate existing permanent benchmarks, control points, and similar reference points before beginning Work. Preserve and protect permanent benchmarks and control points during construction operations.
 - 1. Do not change or relocate existing benchmarks or control points without prior written approval of Architect. Promptly report lost or destroyed permanent benchmarks or control points. Report need to relocate permanent benchmarks or control points to Architect before proceeding.
 - 2. Promptly replace lost or destroyed permanent benchmarks and control points. Base replacements on original survey control points.
- C. Benchmarks: Establish and maintain a minimum of 2 permanent benchmarks on Project site, referenced to data established by survey control points. Comply with authorities having jurisdiction for type and size of benchmark.
 - 1. Record benchmark locations, with horizontal and vertical data, on Project record documents.
 - 2. Where actual location or elevation of layout points cannot be marked, provide temporary reference points sufficient to locate Work.
 - 3. Remove temporary reference points when no longer needed. Restore marked construction to its original condition.
- D. Certified Survey: On completion of foundation walls, major site improvements, and other Work requiring field-engineering services, prepare a certified survey showing dimensions, locations, angles, and elevations of construction and sitework.
- E. Final Property Survey: Engage a land surveyor to prepare a final property survey showing significant features (real property) for Project. Include on survey a certification, signed by land surveyor, that principal metes, bounds, lines, and levels of Project are accurately positioned as shown on survey.
 - 1. Show boundary lines, monuments, streets, site improvements and utilities, existing improvements and significant vegetation, adjoining properties, acreage, grade contours, and distance and bearing from a site corner to a legal point.

2. Recording: At Substantial Completion, have final property survey recorded by or with authorities having jurisdiction as official "property survey."

3.5 INSTALLATION

- A. Locate Work and components of Work accurately, in correct alignment and elevation, as indicated.
 1. Make vertical Work plumb and make horizontal Work level.
 2. Where space is limited, install components to maximize space available for maintenance and ease of removal for replacement.
 3. Conceal pipes, ducts, and wiring in finished areas unless otherwise indicated.
 4. Maintain minimum headroom clearance of 96 inches in occupied spaces and 90 inches in unoccupied spaces.
- B. Comply with manufacturer's written instructions and recommendations for installing products in applications indicated.
- C. Install products at time and under conditions that will ensure best possible results. Maintain conditions required for product performance until Substantial Completion.
- D. Conduct construction operations so no part of Work is subjected to damaging operations or loading in excess of that expected during normal conditions of occupancy.
- E. Sequence Work and allow adequate clearances to accommodate movement of construction items on site and placement in permanent locations.
- F. Tools and Equipment: Where possible, select tools or equipment that minimize production of excessive noise levels.
- G. Templates: Obtain and distribute to parties involved templates for Work specified to be factory prepared and field installed. Check Shop Drawings of other portions of Work to confirm that adequate provisions are made for locating and installing products to comply with indicated requirements.
- H. Attachment: Provide blocking and attachment plates and anchors and fasteners of adequate size and number to securely anchor each component in place, accurately located and aligned with other portions of Work. Where size and type of attachments are not indicated, verify size and type required for load conditions.
 1. Mounting Heights: Where mounting heights are not indicated, mount components at heights directed by Architect.
 2. Allow for building movement, including thermal expansion and contraction.
 3. Coordinate installation of anchorages. Furnish setting drawings, templates, and directions for installing anchorages, including sleeves, concrete inserts, anchor bolts, and items with integral anchors, that are to be embedded in concrete or masonry. Deliver such items to Project site in time for installation.
- I. Joints: Make joints of uniform width. Where joint locations in exposed Work are not indicated, arrange joints for the best visual effect. Fit exposed connections together to form hairline joints.
- J. Repair or remove and replace damaged, defective, or nonconforming Work.
 1. Comply with Section 017700 – Closeout Procedures for repairing or removing and replacing defective Work.

3.6 COORDINATION OF OWNER'S PORTION OF WORK

- A. Site Access: Provide access to Project site for Owner's construction personnel.
 1. Provide temporary facilities required for Owner-furnished, Contractor-installed products.
 2. Refer to Section 011100 – Summary of Work for other requirements for Owner-furnished, Contractor-installed products

- B. Coordination: Coordinate construction and operations of Work with work performed by Owner's construction personnel.
 - 1. Construction Schedule: Inform Owner of Contractor's preferred construction schedule for Owner's portion of Work. Adjust construction schedule based on a mutually agreeable timetable. Notify Owner if changes to schedule are required due to differences in actual construction progress.
 - 2. Preinstallation Meetings: Include Owner's construction personnel at preinstallation meetings covering portions of Work that are to receive Owner's work. Attend preinstallation meetings conducted by Owner's construction personnel if portions of Work depend on Owner's construction.

3.7 PROGRESS CLEANING

- A. Clean Project site and Work areas daily, including common areas. Enforce requirements strictly. Lawfully dispose of materials.
 - 1. Comply with requirements in NFPA 241 for removal of combustible waste materials and debris.
 - 2. Do not hold waste materials more than 7 days during normal weather or 3 days if temperature is expected to rise above 80 deg F.
 - 3. Containerize hazardous and unsanitary waste materials separately from other waste. Mark containers appropriately and dispose of legally, according to regulations.
 - a. Use containers intended for holding waste materials of type to be stored.
- B. Site: Maintain Project site free of waste materials and debris.
- C. Work Areas: Clean areas where Work is in progress to the level of cleanliness necessary for proper execution of Work.
 - 1. Promptly remove liquid spills.
 - 2. Where dust would impair proper execution of Work, broom-clean or vacuum entire Work area, as appropriate.
- D. Installed Work: Keep installed Work clean. Clean installed surfaces according to written instructions of manufacturer or fabricator of product installed, using only cleaning materials specifically recommended. If specific cleaning materials are not recommended, use cleaning materials that are not hazardous to health or property and that will not damage exposed surfaces.
- E. Concealed Spaces: Remove debris from concealed spaces before enclosing space.
- F. Exposed Surfaces in Finished Areas: Clean exposed surfaces and protect as necessary to ensure freedom from damage and deterioration at time of Substantial Completion.
- G. Waste Disposal: Do not bury or burn waste materials on-site. Do not wash waste materials down sewers or into waterways. Comply with waste disposal requirements in Section 017419 – Construction Waste Management and Disposal.
- H. During handling and installation, clean and protect construction in progress and adjoining materials already in place. Apply protective covering where required to ensure protection from damage or deterioration at Substantial Completion.
- I. Clean and provide maintenance on completed construction as frequently as necessary through remainder of construction period. Adjust and lubricate operable components to ensure operability without damaging effects.
- J. Limiting Exposures: Supervise construction operations to ensure that no part of construction, completed or in progress, is subject to harmful, dangerous, damaging, or otherwise deleterious exposure during the construction period.

3.8 STARTING AND ADJUSTING

- A. Coordinate startup and adjusting of equipment and operating components with requirements in Section 019113 – General Commissioning Requirements.
- B. Start equipment and operating components to confirm proper operation. Remove malfunctioning units, replace with new units, and retest.
- C. Adjust equipment for proper operation. Adjust operating components for proper operation without binding.
- D. Test each piece of equipment to verify proper operation. Test and adjust controls and safeties. Replace damaged and malfunctioning controls and equipment.
- E. Manufacturer's Field Service: Comply with qualification requirements in Section 014000 – Quality Requirements.

3.9 PROTECTION OF INSTALLED CONSTRUCTION

- A. Provide final protection and maintain conditions that ensure installed Work is without damage or deterioration at time of Substantial Completion.
- B. Protection of Existing Items: Provide protection and ensure that existing items to remain undisturbed by construction are maintained in condition that existed at commencement of Work.
- C. Comply with manufacturer's written instructions for temperature and relative humidity.

END OF SECTION 017300

SECTION 017419
CONSTRUCTION WASTE MANAGEMENT AND DISPOSAL

PART 1 - GENERAL

1.1 SUMMARY

- A. Section Includes:
 - 1. Administrative and procedural requirements for the following:
 - a. Salvaging nonhazardous [demolition] [and] [construction] waste.
 - b. Recycling nonhazardous [demolition] [and] [construction] waste.
 - c. Disposing of nonhazardous [demolition] [and] [construction] waste.

1.2 DEFINITIONS

- A. Disposal: Removal of demolition or construction waste and subsequent salvage, sale, recycling, or deposit in landfill, incinerator acceptable to authorities having jurisdiction, or designated spoil areas on Owner's property.
- B. Recycle: Recovery of demolition or construction waste for subsequent processing in preparation for reuse.
- C. Salvage: Recovery of demolition or construction waste and subsequent sale or reuse in another facility.
- D. Salvage and Reuse: Recovery of demolition or construction waste and subsequent incorporation into Work.

1.3 MATERIALS OWNERSHIP

- A. Unless otherwise indicated, demolition and construction waste becomes property of Contractor.

1.4 ACTION SUBMITTALS

- A. Waste Management Plan: Submit plan within [14] days of date established for Notice to Proceed

1.5 INFORMATIONAL SUBMITTALS

- A. Waste Reduction Progress Reports: Concurrent with each Application for Payment, submit report. Use appropriate CWM Forms. Include the following information:
 - 1. Material category.
 - 2. Generation point of waste.
 - 3. Total quantity of waste in tons.
 - 4. Quantity of waste salvaged, both estimated and actual in tons.
 - 5. Quantity of waste recycled, both estimated and actual in tons.
 - 6. Total quantity of waste recovered (salvaged plus recycled) in tons.
 - 7. Total quantity of waste recovered (salvaged plus recycled) as a percentage of total waste.
- B. Waste Reduction Calculations: Before request for Substantial Completion, submit calculated end-of-Project rates for salvage, recycling, and disposal as a percentage of total waste generated by Work.
- C. Records of Donations: Indicate receipt and acceptance of salvageable waste donated to individuals and organizations. Indicate whether organization is tax exempt.
- D. Records of Sales: Indicate receipt and acceptance of salvageable waste sold to individuals and organizations. Indicate whether organization is tax exempt.

- E. Recycling and Processing Facility Records: Indicate receipt and acceptance of recyclable waste by recycling and processing facilities licensed to accept them. Include manifests, weight tickets, receipts, and invoices.
- F. Landfill and Incinerator Disposal Records: Indicate receipt and acceptance of waste by landfills and incinerator facilities licensed to accept them. Include manifests, weight tickets, receipts, and invoices.
- G. ESDS Submittal: Demonstrate compliance with ESDS credit 6.3 Construction Waste Management as described in the EPP and ESDS checklist to obtain 5 points for this credit.
- H. Qualification Data: For [waste management coordinator] [and] [refrigerant recovery technician].
- I. Statement of Refrigerant Recovery: Signed by refrigerant recovery technician responsible for recovering refrigerant, stating that refrigerant that was present was recovered and that recovery was performed according to EPA regulations. Include name and address of technician and date refrigerant was recovered.
- J. Refrigerant Recovery: Comply with requirements in [Section 024116 – Structure Demolition] [Section 024119 – Selective Demolition] for refrigerant recovery submittals.

1.6 QUALITY ASSURANCE

- A. Waste Management Coordinator Qualifications: Experienced firm, or individual employed and assigned by Contractor, with a record of successful waste management coordination of projects with similar requirements. Superintendent may [may not] serve as Waste Management Coordinator.
 - 1. Firm employs a LEED-Accredited Professional, certified by USGBC, as waste management coordinator.
 - 2. Waste management coordinator may also serve as LEED coordinator.
- B. Refrigerant Recovery Technician Qualifications: [Type I] [Type II] [Type III] [Universal] certified by EPA-approved certification program.
- C. Regulatory Requirements: Comply with transportation and disposal regulations of authorities having jurisdiction.
- D. Waste Management Meetings: Conduct meetings at Project site. Review methods and procedures related to waste management including the following:
 - 1. Discuss waste management plan including responsibilities of each entity and waste management coordinator.
 - 2. Requirements for documenting quantities of each type of waste and its disposition.
 - 3. Finalize procedures for materials separation and verify availability of containers and bins needed to avoid delays.
 - 4. Procedures for periodic waste collection and transportation to recycling and disposal facilities.
 - 5. Waste management requirements for each trade.

1.7 WASTE MANAGEMENT PLAN

- A. General: Develop a waste management plan according to requirements in this Section. Plan shall consist of waste identification, waste reduction work plan, and cost/revenue analysis. [Distinguish between demolition and construction waste.] Indicate quantities by weight or volume, but use same units of measure throughout waste management plan.
- B. Waste Identification: Indicate anticipated types and quantities of [demolition] [site-clearing] [and] [construction] waste generated by Work. Use appropriate CWM Forms. Include estimated quantities and assumptions for estimates.
- C. Waste Reduction Work Plan: List each type of waste and whether it will be salvaged, recycled, or disposed of in landfill or incinerator. Use appropriate CWM Forms. Include points of waste

generation, total quantity of each type of waste, quantity for each means of recovery, and handling and transportation procedures.

1. Salvaged Materials for Reuse: For materials that will be salvaged and reused in this Project, describe methods for preparing salvaged materials before incorporation into Work in compliance with [**Section 024116 – Structure Demolition.**] [**Section 024119 – Selective Demolition.**]
 2. Salvaged Materials for Sale: For materials that will be sold to individuals and organizations, include list of their names, addresses, and telephone numbers.
 3. Salvaged Materials for Donation: For materials that will be donated to individuals and organizations, include list of their names, addresses, and telephone numbers.
 4. Recycled Materials: Include list of local receivers and processors and type of recycled materials each will accept. Include names, addresses, and telephone numbers.
 5. Disposed Materials: Indicate how and where materials will be disposed of. Include name, address, and telephone number of each landfill and incinerator facility.
 6. Handling and Transportation Procedures: Include method that will be used for separating recyclable waste including sizes of containers, container labeling, and designated location where materials separation will be performed.
- D. Cost/Revenue Analysis: Indicate total cost of waste disposal as if there were no waste management plan and net additional cost or net savings resulting from implementing waste management plan. Use appropriate CWM Forms. Include the following:
1. Total quantity of waste.
 2. Estimated cost of disposal (cost per unit). Include transportation and tipping fees and cost of collection containers and handling for each type of waste.
 3. Total cost of disposal (with no waste management).
 4. Revenue from salvaged materials.
 5. Revenue from recycled materials.
 6. Savings in transportation and tipping fees by donating materials.
 7. Savings in transportation and tipping fees that are avoided.
 8. Handling and transportation costs. Include cost of collection containers for each type of waste.
 9. Net additional cost or net savings from waste management plan.

PART 2 - PRODUCTS

2.1 RECYCLING RECEIVERS AND PROCESSORS

- A. Subject to compliance with requirements, available recycling receivers and processors include the following:
1. Rubatino Refuse Removal Inc.
 - a. <http://rubatino.com/>
 2. Waste Management Northwest
 - a. <http://www.wmnorthwest.com/snohomishcounty/>

2.2 PERFORMANCE CRITERIA

- A. General: Achieve end-of-Project rates for salvage/recycling of 75 percent by weight of total nonhazardous solid waste generated by Work. Practice efficient waste management in use of materials in course of Work. Use reasonable means to divert construction and demolition waste from landfills and incinerators. Facilitate recycling and salvage of materials, including the following:
1. Demolition Waste:
 - a. Asphalt paving.
 - b. Concrete.
 - c. Concrete reinforcing steel.
 - d. Brick.
 - e. Concrete masonry units.

- f. Wood studs.
- g. Wood joists.
- h. Plywood and oriented strand board.
- i. Wood paneling.
- j. Wood trim.
- k. Structural and miscellaneous steel.
- l. Rough hardware.
- m. Roofing.
- n. Insulation.
- o. Doors and frames.
- p. Door hardware.
- q. Windows.
- r. Glazing.
- s. Metal studs.
- t. Gypsum board.
- u. Acoustical tile and panels.
- v. Carpet.
- w. Carpet pad.
- x. Demountable partitions.
- y. Equipment.
- z. Cabinets.
- aa. Plumbing fixtures.
- bb. Piping.
- cc. Supports and hangers.
- dd. Valves.
- ee. Sprinklers.
- ff. Mechanical equipment.
- gg. Refrigerants.
- hh. Electrical conduit.
- ii. Copper wiring.
- jj. Lighting fixtures.
- kk. Lamps.
- ll. Ballasts.
- mm. Electrical devices.
- nn. Switchgear and panelboards.
- oo. Transformers.
- 2. Construction Waste:
 - a. Masonry and CMU.
 - b. Lumber.
 - c. Wood sheet materials.
 - d. Wood trim.
 - e. Metals.
 - f. Roofing.
 - g. Insulation.
 - h. Carpet and pad.
 - i. Gypsum board.
 - j. Piping.
 - k. Electrical conduit.
 - l. Packaging: Regardless of salvage/recycle goal indicated in "General" Paragraph above, salvage or recycle 100 percent of the following uncontaminated packaging materials:
 - 1) Paper.
 - 2) Cardboard.
 - 3) Boxes.
 - 4) Plastic sheet and film.

- 5) Polystyrene packaging.
- 6) Wood crates.
- 7) Wood pallets.
- 8) Plastic pails.
- m. Construction Office Waste: Regardless of salvage/recycle goal indicated in "General" Paragraph above, salvage or recycle 100 percent of the following construction office waste materials:
 - 1) Polystyrene packing material
 - 2) Cardboard
 - 3) Paper.
 - 4) Aluminum cans.
 - 5) Glass containers.

PART 3 - EXECUTION

3.1 PLAN IMPLEMENTATION

- A. General: Implement approved waste management plan. Provide handling, containers, storage, signage, transportation, and other items as required to implement waste management plan during entire duration of Contract.
 1. Comply with operation, termination, and removal requirements in Section 015000 – Temporary Facilities and Controls.
- B. Waste Management Coordinator: Engage a waste management coordinator to be responsible for implementing, monitoring, and reporting status of waste management Work plan. [**Coordinator shall be present at Project site full time for duration of Project.**]
- C. Training: Train workers, Subcontractors, and suppliers on proper waste management procedures, as appropriate for Work.
 1. Distribute waste management plan to everyone concerned within 3 days of submittal return.
 2. Distribute waste management plan to entities when they first begin Work on-site. Review plan procedures and locations established for salvage, recycling, and disposal.
- D. Site Access and Temporary Controls: Conduct waste management operations to ensure minimum interference with roads, streets, walks, walkways, and other adjacent occupied and used facilities.
 1. Designate and label specific areas on Project site necessary for separating materials that are to be salvaged and recycled.
 2. Comply with Section 015000 – Temporary Facilities and Controls for controlling dust and dirt, environmental protection, and noise control.
- E. Waste Management in Historic Zones or Areas: Transportation equipment and other materials shall be of sizes that clear surfaces within historic spaces, areas, rooms, and openings, by 12 inches or more.

3.2 SALVAGING DEMOLITION WASTE

- A. Comply with requirements in [Section 024116 – Structure Demolition] [Section 024119 – Selective Demolition] for salvaging demolition waste.
- B. Salvaged Items for Reuse in Work: Salvage items for reuse and handle as follows:
 1. Clean salvaged items.
 2. Pack or crate items after cleaning. Identify contents of containers with label indicating elements, date of removal, quantity, and location where removed.
 3. Store items in a secure area until installation.
 4. Protect items from damage during transport and storage.

5. Install salvaged items to comply with installation requirements for new materials and equipment. Provide connections, supports, and miscellaneous materials necessary to make items functional for use indicated.
- C. **Salvaged Items for [Sale] [and] [Donation]:** [**[Not permitted]** on Project site.
 - D. Salvaged Items for Owner's Use: Salvage items for Owner's use and handle as follows:
 1. Clean salvaged items.
 2. Pack or crate items after cleaning. Identify contents of containers with label indicating elements, date of removal, quantity, and location where removed.
 3. Store items in a secure area until delivery to Owner.
 4. Transport items to Owner's storage area **[on-site] [off-site]** designated by Owner.
 5. Protect items from damage during transport and storage.
 - E. Doors and Hardware: Brace open end of door frames. Except for removing door closers, leave door hardware attached to doors.
 - F. Equipment: Drain tanks, piping, and fixtures. Seal openings with caps or plugs. Protect equipment from exposure to weather.
 - G. Plumbing Fixtures: Separate by type and size.
 - H. Lighting Fixtures: Separate lamps by type and protect from breakage.
 - I. Electrical Devices: Separate switches, receptacles, switchgear, transformers, meters, panelboards, circuit breakers, and other devices by type.
- 3.3 RECYCLING **[DEMOLITION] [AND] [CONSTRUCTION]** WASTE, GENERAL
- A. General: Recycle paper and beverage containers used by on-site workers.
 - B. Recycling Incentives: Revenues, savings, rebates, tax credits, and other incentives received for recycling waste materials shall accrue to Contractor unless indicated otherwise.
 - C. Preparation of Waste: Prepare and maintain recyclable waste materials according to recycling or reuse facility requirements. Maintain materials free of dirt, adhesives, solvents, petroleum contamination, and other substances deleterious to recycling process.
 - D. Procedures: Separate recyclable waste from other waste materials, trash, and debris. Separate recyclable waste by type at Project site to maximum extent practical according to approved construction waste management plan.
 1. Provide appropriately marked containers or bins for controlling recyclable waste until removed from Project site. Include list of acceptable and unacceptable materials at each container and bin.
 - a. Inspect containers and bins for contamination and remove contaminated materials if found.
 2. Stockpile processed materials on-site without intermixing with other materials. Place, grade, and shape stockpiles to drain surface water. Cover to prevent windblown dust.
 3. Stockpile materials away from construction area. Do not store within drip line of remaining trees.
 4. Store components off ground and protect from weather.
 5. Remove recyclable waste from Owner's property and transport to recycling receiver or processor as often as required to prevent overfilling bins.
- 3.4 RECYCLING DEMOLITION WASTE
- A. Asphalt Paving: Grind asphalt to maximum **[1-1/2-inch] [4-inch]** size.

1. Crush asphaltic concrete paving and screen to comply with requirements in Division 31 Section for Earth Moving for use as general fill.
 - B. Asphalt Paving: Break up and transport paving to asphalt-recycling facility.
 - C. Concrete: Remove reinforcement and other metals from concrete and sort with other metals.
 1. Pulverize concrete to maximum [1-1/2-inch] [4-inch] size.
 2. Crush concrete and screen to comply with requirements in Division 31 Section for Earth Moving for use as satisfactory soil for fill or subbase.
 - D. Masonry: Remove metal reinforcement, anchors, and ties from masonry and sort with other metals.
 1. Pulverize masonry to maximum [3/4-inch] [1-inch] [1-1/2-inch] [4-inch] size.
 - a. Crush masonry and screen to comply with requirements in Division 31 Section for Earth Moving for use as **general fill** [**satisfactory soil for fill or subbase**].
 - b. Crush masonry and screen to comply with requirements in Division 32 Section for Plants for use as mineral mulch.
 2. Clean and stack undamaged, whole masonry units on wood pallets.
 - E. Wood Materials: Sort and stack members according to size, type, and length. Separate lumber, engineered wood products, panel products, and treated wood materials.
 - F. Metals: Separate metals by type.
 1. Structural Steel: Stack members according to size, type of member, and length.
 2. Remove and dispose of bolts, nuts, washers, and other rough hardware.
 - G. Asphalt Shingle Roofing: Separate organic and glass-fiber asphalt shingles and felts. Remove and dispose of nails, staples, and accessories.
 - H. Gypsum Board: Stack large clean pieces on wood pallets or in container and store in a dry location. Remove edge trim and sort with other metals. Remove and dispose of fasteners.
 - I. Acoustical Ceiling Panels and Tile: Stack large clean pieces on wood pallets and store in a dry location.
 - J. Metal Suspension System: Separate metal members, including trim and other metals from acoustical panels and tile, and sort with other metals.
 - K. Carpet[**and Pad**]: Roll large pieces tightly after removing debris, trash, adhesive, and tack strips.
 1. Store clean, dry carpet[**and pad**] in a closed container or trailer provided by carpet reclamation agency or carpet recycler.
 - L. Carpet Tile: Remove debris, trash, and adhesive.
 1. Stack tile on pallet and store clean, dry carpet in a closed container or trailer provided by carpet reclamation agency or carpet recycler.
 - M. Piping: Reduce piping to straight lengths and store by material and size. Separate supports, hangers, valves, sprinklers, and other components by material and size.
 - N. Conduit: Reduce conduit to straight lengths and store by material and size.
 - O. Lamps: Separate lamps by type and store according to requirements in 40 CFR 273.
- 3.5 RECYCLING CONSTRUCTION WASTE
- A. Packaging:
 1. Cardboard and Boxes: Break down packaging into flat sheets. Bundle and store in a dry location.
 2. Polystyrene Packaging: Separate and bag materials.

3. Pallets: As much as possible, require deliveries using pallets to remove pallets from Project site. For pallets that remain on-site, break down pallets into component wood pieces and comply with requirements for recycling wood.
 4. Crates: Break down crates into component wood pieces and comply with requirements for recycling wood.
- B. Wood Materials:
1. Clean Cut-Offs of Lumber : Grind or chip into small pieces.
 2. Clean Sawdust: Bag sawdust that does not contain painted or treated wood.
 - a. Comply with requirements in Division 32 Section for Plants for use of clean sawdust as organic mulch.
- C. Gypsum Board: Stack large clean pieces on wood pallets or in container and store in a dry location.
1. Clean Gypsum Board: Grind scraps of clean gypsum board using small mobile chipper or hammer mill. Screen out paper after grinding.
 - a. Comply with requirements in Division 32 Section for Plants for use of clean ground gypsum board as inorganic soil amendment.
- D. Paint: Seal containers and store by type.

3.6 DISPOSAL OF WASTE

- A. General: Except for items or materials to be salvaged or recycled, remove waste materials from Project site and legally dispose of them in a landfill or incinerator acceptable to authorities having jurisdiction.
1. Except as otherwise specified, do not allow waste materials that are to be disposed of accumulate on-site.
 2. Remove and transport debris in a manner that will prevent spillage on adjacent surfaces and areas.
- B. Burning: Do not burn waste materials.
- C. Burning: Burning of waste materials is permitted only at designated areas on Owner's property, provided required permits are obtained. Provide full-time monitoring for burning materials until fires are extinguished.

END OF SECTION 017419

SECTION 017700
CLOSEOUT PROCEDURES

PART 1 - GENERAL

1.1 SUMMARY

- A. Section Includes:
 - 1. Administrative and procedural requirements for contract closeout, including the following:
 - a. Substantial Completion procedures.
 - b. Final completion procedures.
 - c. Warranties.
 - d. Final cleaning, including final cleaning of HVAC Work.
 - e. Repair of Work.

1.2 DEFINITIONS

- A. List of Incomplete Items: Contractor-prepared list of items to be completed or corrected, prepared for Architect's use prior to Architect's inspection, to determine if Work is substantially complete.

1.3 ACTION SUBMITTALS

- A. Product Data: For each type of cleaning agent.
- B. Contractor's List of Incomplete Items: Initial submittal at Substantial Completion.
- C. Certified List of Incomplete Items: Final submittal at final completion.

1.4 CLOSEOUT SUBMITTALS

- A. Certificates of Release: From authorities having jurisdiction.
- B. Certificate of Insurance: For continuing coverage.
- C. Field Report: For pest-control inspection.

1.5 MAINTENANCE MATERIAL SUBMITTALS

- A. Schedule of Maintenance Material Items: For maintenance material submittal items specified in other Sections.

1.6 SUBSTANTIAL COMPLETION PROCEDURES

- A. Contractor's List of Incomplete Items: Prepare and submit a list of items to be completed and corrected (Contractor's punch list), indicating value of each item on list and reasons why Work is incomplete.
- B. Submittals Prior to Substantial Completion: Complete the following a minimum of **[10 days]** prior to requesting inspection for determining date of Substantial Completion. List items below that are incomplete at time of request.
 - 1. Certificates of Release: Obtain and submit releases from authorities having jurisdiction permitting Owner unrestricted use of Work and access to services and utilities. Include occupancy permits, operating certificates, and similar releases.
 - 2. Submit closeout submittals specified in other Division 01 Sections, including Project record documents, operation and maintenance manuals, damage or settlement surveys, property surveys, and similar final record information.

3. Submit closeout submittals specified in individual Sections, including specific warranties, workmanship bonds, maintenance service agreements, final certifications, and similar documents.
 4. Submit maintenance material submittals specified in individual Sections, including tools, spare parts, extra materials, and similar items, and deliver to location designated by Architect. Label with manufacturer's name and model number.
 - a. Schedule of Maintenance Material Items: Prepare and submit schedule of maintenance material submittal items, including name and quantity of each item and name and number of related Specification Section. Obtain Architect's [**Owner's**] signature for receipt of submittals.
 5. Submit testing, adjusting, and balancing records.
 6. **[Submit sustainable design submittals not previously submitted.]**
 7. [Submit changeover information related to Owner's occupancy, use, operation, and maintenance.
- C. Procedures Prior to Substantial Completion: Complete the following a minimum of **[10 days]** prior to requesting inspection for determining date of Substantial Completion. List items below that are incomplete at time of request.
1. Advise Owner of pending insurance changeover requirements.
 2. Make final changeover of permanent locks and deliver keys to Owner. Advise Owner's personnel of changeover in security provisions.
 3. Complete startup and testing of systems and equipment.
 4. Perform preventive maintenance on equipment used prior to Substantial Completion.
 5. Instruct Owner's personnel in operation, adjustment, and maintenance of products, equipment, and systems. Submit demonstration and training video recordings specified in Section 017900 – Demonstration and Training.
 6. Advise Owner of changeover in utility services.
 7. Participate with Owner in conducting inspection and walkthrough with local emergency responders.
 8. Terminate and remove temporary facilities from Project site, along with mockups, construction tools, and similar elements.
 9. Complete final cleaning requirements.
 10. Touch up paint and otherwise repair and restore marred exposed finishes to eliminate visual defects.
- D. Inspection: Submit a written request for inspection to determine Substantial Completion a minimum of **[10 days]** prior to date Work will be completed and ready for final inspection and tests. On receipt of request, Architect will either proceed with inspection or notify Contractor of unfulfilled requirements. Architect will prepare Certificate of Substantial Completion after inspection or will notify Contractor of items, either on Contractor's list or additional items identified by Architect, that must be completed or corrected before certificate will be issued.
1. Request reinspection when Work identified in previous inspections as incomplete is completed or corrected.
 2. Results of completed inspection will form basis of requirements for final completion.
- 1.7 FINAL COMPLETION PROCEDURES
- A. Submittals Prior to Final Completion: Before requesting final inspection for determining final completion, complete the following:
1. Submit a final Application for Payment according to Section 012900 – Payment Procedures.
 2. Certified List of Incomplete Items: Submit certified copy of Architect's Substantial Completion inspection list of items to be completed or corrected (punch list), endorsed and dated by Architect. Certified copy of list shall state that each item has been completed or otherwise resolved for acceptance.

3. Certificate of Insurance: Submit evidence of final, continuing insurance coverage complying with insurance requirements.
 4. Submit final completion photographic documentation.
- B. Inspection: Submit a written request for final inspection to determine acceptance a minimum of **[10 days]** prior to date Work will be completed and ready for final inspection and tests. On receipt of request, Architect will either proceed with inspection or notify Contractor of unfulfilled requirements. Architect will prepare a final Certificate for Payment after inspection or will notify Contractor of construction that must be completed or corrected before certificate will be issued.
1. Request reinspection when Work identified in previous inspections as incomplete is completed or corrected.

1.8 LIST OF INCOMPLETE ITEMS (PUNCH LIST)

- A. Organization of List: Include name and identification of each space and area affected by construction operations for incomplete items and items needing correction including, if necessary, areas disturbed by Contractor that are outside limits of construction.
1. Organize list of spaces in sequential order, starting with exterior areas first and proceeding from lowest floor to highest floor.
 2. Organize items applying to each space by major element, including categories for ceiling, individual walls, floors, equipment, and building systems.
 3. Include the following information at top of each page:
 - a. Project name.
 - b. Date.
 - c. Name of Architect.
 - d. Name of Contractor.
 - e. Page number.
 4. Submit list of incomplete items in PDF electronic file in compliance with Digital Information Management System requirements in Section 013100 – Project Management and Coordination. Architect will return annotated file.

1.9 SUBMITTAL OF PROJECT WARRANTIES

- A. Time of Submittal: Submit written warranties on request of Architect for designated portions of Work where warranties are indicated to commence on dates other than date of Substantial Completion, or when delay in submittal of warranties might limit Owner's rights under warranty.
- B. Partial Occupancy: Submit properly executed warranties within **[15 days]** of completion of designated portions of Work that are completed and occupied or used by Owner during construction period by separate agreement with Contractor.
- C. Organize warranty documents into an orderly sequence based on table of contents of the Specifications.
- D. Warranty Electronic File: Provide warranties and bonds in PDF format. Assemble complete warranty and bond submittal package into a single electronic PDF file with bookmarks enabling navigation to each item. Provide bookmarked table of contents at beginning of document.
1. Submit in compliance with Digital Information Management System requirements in Section 013100 – Project Management and Coordination.

PART 2 - PRODUCTS

2.1 MATERIALS

- A. Cleaning Agents: Use cleaning materials and agents recommended by manufacturer or fabricator of surface to be cleaned. Do not use cleaning agents that are potentially hazardous to health or property or that might damage finished surfaces.
 - 1. Use cleaning products that comply with Green Seal's GS-37, or if GS-37 is not applicable, use products that comply with the California Code of Regulations maximum allowable VOC levels.

PART 3 - EXECUTION

3.1 FINAL CLEANING

- A. General: Perform final cleaning. Conduct cleaning and waste-removal operations to comply with local laws and ordinances and Federal and local environmental and antipollution regulations.
- B. Cleaning: Employ experienced workers or professional cleaners for final cleaning. Clean each surface or unit to condition expected in an average commercial building cleaning and maintenance program. Comply with manufacturer's written instructions.
 - 1. Complete the following cleaning operations before requesting inspection for certification of Substantial Completion for entire Project or for a designated portion of Project:
 - a. Clean Project site, yard, and grounds, in areas disturbed by construction activities, including landscape development areas, of rubbish, waste material, litter, and other foreign substances.
 - b. Sweep paved areas broom clean. Remove petrochemical spills, stains, and other foreign deposits.
 - c. Rake grounds that are not planted, mulched, or paved to a smooth, even-textured surface.
 - d. Remove tools, construction equipment, machinery, and surplus material from Project site.
 - e. Remove snow and ice to provide safe access to building.
 - f. Clean exposed exterior and interior hard-surfaced finishes to a dirt-free condition, free of stains, films, and similar foreign substances. Avoid disturbing natural weathering of exterior surfaces. Restore reflective surfaces to their original condition.
 - g. Remove debris and surface dust from limited access spaces, including roofs, plenums, shafts, trenches, equipment vaults, manholes, attics, and similar spaces.
 - h. Sweep concrete floors broom clean in unoccupied spaces.
 - i. Vacuum carpet and similar soft surfaces, removing debris and excess nap; clean according to manufacturer's recommendations if visible soil or stains remain.
 - j. Clean transparent materials, including mirrors and glass in doors and windows. Remove glazing compounds and other noticeable, vision-obscuring materials. Polish mirrors and glass, taking care not to scratch surfaces.
 - k. Remove labels that are not permanent.
 - l. Wipe surfaces of mechanical and electrical equipment[, **elevator equipment,**] and similar equipment. Remove excess lubrication, paint and mortar droppings, and other foreign substances.
 - m. Clean plumbing fixtures to a sanitary condition, free of stains, including stains resulting from water exposure.
 - n. Replace disposable air filters and clean permanent air filters. Clean exposed surfaces of diffusers, registers, and grills.
 - o. Clean ducts, blowers, and coils if units were operated without filters during construction or that display contamination with particulate matter on inspection.

- 1) Clean HVAC system in compliance with Division 23 Section for Existing HVAC Air-Distribution System Cleaning. Provide written report on completion of cleaning.
 - p. Clean luminaires, lamps, globes, and reflectors to function with full efficiency.
 - q. Leave Project clean and ready for occupancy.
- C. [Pest Control: Comply with pest control requirements in Section 015000 – Temporary Facilities and Controls. Prepare written report.
- D. [Construction Waste Disposal: Comply with waste disposal requirements in [Section 015000 – Temporary Facilities and Controls] [Section 017419 – Construction Waste Management and Disposal].

3.2 REPAIR OF WORK

- A. Complete repair and restoration operations before requesting inspection for determination of Substantial Completion.
- B. Repair, or remove and replace, defective construction. Repairing includes replacing defective parts, refinishing damaged surfaces, touching up with matching materials, and properly adjusting operating equipment. Where damaged or worn items cannot be repaired or restored, provide replacements. Remove and replace operating components that cannot be repaired. Restore damaged construction and permanent facilities used during construction to specified condition.
1. Remove and replace chipped, scratched, and broken glass, reflective surfaces, and other damaged transparent materials.
 2. Touch up and otherwise repair and restore marred or exposed finishes and surfaces. Replace finishes and surfaces that that already show evidence of repair or restoration.
 - a. Do not paint over "UL" and other required labels and identification, including mechanical and electrical nameplates. Remove paint applied to required labels and identification.
 3. Replace parts subject to operating conditions during construction that may impede operation or reduce longevity.
 4. Replace burned-out bulbs, bulbs noticeably dimmed by hours of use, and defective and noisy starters in fluorescent and mercury vapor fixtures to comply with requirements for new fixtures.

END OF SECTION 017700

SECTION 017823
OPERATION AND MAINTENANCE DATA

PART 1 - GENERAL

1.1 SUMMARY

A. Section Includes:

1. Administrative and procedural requirements for preparing operation and maintenance manuals, including the following:
 - a. Operation and maintenance documentation directory manuals.
 - b. Emergency manuals.
 - c. Systems and equipment operation manuals.
 - d. Systems and equipment maintenance manuals.
 - e. Product maintenance manuals.

1.2 DEFINITIONS

- A. System: An organized collection of parts, equipment, or subsystems united by regular interaction.
- B. Subsystem: A portion of a system with characteristics similar to a system.

1.3 ADMINISTRATIVE REQUIREMENTS

- A. Coordination: Where operation and maintenance documentation includes information on installations by more than 1 factory-authorized service representative, assemble and coordinate information furnished by each representative and prepare manuals.

1.4 CLOSEOUT SUBMITTALS

- A. Submit operation and maintenance manuals indicated. Provide content for each manual as specified in individual Specification Sections, and as reviewed and approved at time of Section submittals. Submit reviewed manual content formatted and organized as required by this Section.
 1. Architect[**and Commissioning Authority**] will comment on whether content of operation and maintenance submittals is acceptable.
 2. Where applicable, clarify and update reviewed manual content to correspond to revisions and field conditions.
- B. Format: Submit operation and maintenance manuals in accordance with Digital Information Management System requirements as specified in Section 013100 – Project Management and Coordination.
 1. PDF Electronic File. Assemble each manual into composite electronically indexed file.
 - a. Name each indexed document file in composite electronic index with applicable item name. Include complete electronically linked operation and maintenance directory.
 - b. Enable inserted reviewer comments on draft submittals.
- C. Initial Manual Submittal: Submit draft copy of each manual at least **30 days** before commencing demonstration and training. Architect[**and Commissioning Authority**] will comment on whether general scope and content of manual are acceptable.
- D. Final Manual Submittal: Submit each manual in final form prior to requesting inspection for Substantial Completion and at least **15 days** before commencing demonstration and training. Architect[**and Commissioning Authority**] will return copy with comments.
 1. Correct or revise each manual to comply with Architect's[**and Commissioning Authority's**] comments. Submit copies of each corrected manual within **15 days** of receipt of

Architect's[**and Commissioning Authority's**] comments and prior to commencing demonstration and training.

- E. Comply with Section 017700 – Closeout Procedures for schedule for submitting operation and maintenance documentation.

1.5 FORMAT OF OPERATION AND MAINTENANCE MANUALS

- A. Manuals, Electronic Files: Submit manuals in the form of a multiple file composite electronic PDF file for each manual type required.
 - 1. Electronic Files: Use electronic files prepared by manufacturer where available. Where scanning of paper documents is required, configure scanned file for minimum readable file size.
 - 2. File Names and Bookmarks: Bookmark individual documents based on file names. Name document files to correspond to system, subsystem, and equipment names used in manual directory and table of contents. Group documents for each system and subsystem into individual composite bookmarked files, then create composite manual, so that resulting bookmarks reflect system, subsystem, and equipment names in a readily navigated file tree. Configure electronic manual to display bookmark panel on opening file.

1.6 REQUIREMENTS FOR EMERGENCY, OPERATION, AND MAINTENANCE MANUALS

- A. Organization of Manuals: Unless otherwise indicated, organize each manual into a separate section for each system and subsystem, and a separate section for each piece of equipment not part of a system. Each manual shall contain the following materials, in the order listed:
 - 1. Title page.
 - 2. Table of contents.
 - 3. Manual contents.
- B. Title Page: Include the following information:
 - 1. Subject matter included in manual.
 - 2. Name and address of Project.
 - 3. Name and address of Owner.
 - 4. Date of submittal.
 - 5. Name and contact information for Contractor.
 - 6. Name and contact information for Architect.
 - 7. **[Name and contact information for Commissioning Authority.**
 - 8.]Names and contact information for major consultants to Architect that designed systems contained in manuals.
 - 9. Cross-reference to related systems in other operation and maintenance manuals.
- C. Table of Contents: List each product included in manual, identified by product name, indexed to content of volume, and cross-referenced to Specification Section number in Project Manual.
 - 1. If operation or maintenance documentation requires more than 1 volume to accommodate data, include comprehensive table of contents for each volume of set.
- D. Manual Contents: Organize into sets of manageable size. Arrange contents alphabetically by system, subsystem, and equipment. If possible, assemble instructions for subsystems, equipment, and components of 1 system into a single binder.
- E. Identification: In documentation directory and in each operation and maintenance manual, identify each system, subsystem, and piece of equipment with same designation used in Contract Documents. If no designation exists, assign designation according to ASHRAE Guideline 4, "Preparation of Operating and Maintenance Documentation for Building Systems."

1.7 OPERATION AND MAINTENANCE DOCUMENTATION DIRECTORY MANUAL

- A. Operation and Maintenance Documentation Directory: Prepare a separate manual that provides an organized reference to emergency, operation, and maintenance manuals. List items and their location to facilitate ready access to desired information. Include the following:
 - 1. List of Systems and Subsystems: List systems alphabetically. Include references to operation and maintenance manuals that contain information about each system.
 - 2. List of Equipment: List equipment for each system, organized alphabetically by system. For pieces of equipment not part of system, list alphabetically in separate list.
 - 3. Tables of Contents: Include a table of contents for each emergency, operation, and maintenance manual.

1.8 EMERGENCY MANUALS

- A. Emergency Manual: Assemble a complete set of emergency information indicating procedures for use by emergency personnel and by Owner's operating personnel for types of emergencies indicated.
- B. Content: Organize manual into a separate section for each of the following:
 - 1. Type of emergency.
 - 2. Emergency instructions.
 - 3. Emergency procedures.
- C. Type of Emergency: Where applicable for each type of emergency indicated below, include instructions and procedures for each system, subsystem, piece of equipment, and component:
 - 1. Fire.
 - 2. Flood.
 - 3. Gas leak.
 - 4. Water leak.
 - 5. Power failure.
 - 6. Water outage.
 - 7. System, subsystem, or equipment failure.
 - 8. Chemical release or spill.
- D. Emergency Instructions: Describe and explain warnings, trouble indications, error messages, and similar codes and signals. Include responsibilities of Owner's operating personnel for notification of Installer, supplier, and manufacturer to maintain warranties.
- E. Emergency Procedures: Include the following, as applicable:
 - 1. Instructions on stopping.
 - 2. Shutdown instructions for each type of emergency.
 - 3. Operating instructions for conditions outside normal operating limits.
 - 4. Required sequences for electric or electronic systems.
 - 5. Special operating instructions and procedures.

1.9 SYSTEMS AND EQUIPMENT OPERATION MANUALS

- A. Systems and Equipment Operation Manual: Assemble a complete set of data indicating operation of each system, subsystem, and piece of equipment not part of a system. Include information required for daily operation and management, operating standards, and routine and special operating procedures.
 - 1. Engage a factory-authorized service representative to assemble and prepare information for each system, subsystem, and piece of equipment not part of a system.
 - 2. Prepare a separate manual for each system and subsystem, in form of an instructional manual for use by Owner's operating personnel.

- B. Content: In addition to requirements in this Section, include operation data required in individual Specification Sections and the following information:
 - 1. System, subsystem, and equipment descriptions. Use designations for systems and equipment indicated on Contract Documents.
 - 2. Performance and design criteria if Contractor has delegated design responsibility.
 - 3. Operating standards.
 - 4. Operating procedures.
 - 5. Operating logs.
 - 6. Wiring diagrams.
 - 7. Control diagrams.
 - 8. Piped system diagrams.
 - 9. Precautions against improper use.
 - 10. License requirements including inspection and renewal dates.
 - C. Descriptions: Include the following:
 - 1. Product name and model number. Use designations for products indicated on Contract Documents.
 - 2. Manufacturer's name.
 - 3. Equipment identification with serial number of each component.
 - 4. Equipment function.
 - 5. Operating characteristics.
 - 6. Limiting conditions.
 - 7. Performance curves.
 - 8. Engineering data and tests.
 - 9. Complete nomenclature and number of replacement parts.
 - D. Operating Procedures: Include the following, as applicable:
 - 1. Startup procedures.
 - 2. Equipment or system break-in procedures.
 - 3. Routine and normal operating instructions.
 - 4. Regulation and control procedures.
 - 5. Instructions on stopping.
 - 6. Normal shutdown instructions.
 - 7. Seasonal and weekend operating instructions.
 - 8. Required sequences for electric or electronic systems.
 - 9. Special operating instructions and procedures.
 - E. Systems and Equipment Controls: Describe sequence of operation, and diagram controls as installed.
 - F. Piped Systems: Diagram piping as installed, and identify color coding where required for identification.
- 1.10 SYSTEMS AND EQUIPMENT MAINTENANCE MANUALS
- A. Systems and Equipment Maintenance Manuals: Assemble a complete set of data indicating maintenance of each system, subsystem, and piece of equipment not part of a system. Include manufacturers' maintenance documentation, preventive maintenance procedures and frequency, repair procedures, wiring and systems diagrams, lists of spare parts, and warranty information.
 - 1. Engage a factory-authorized service representative to assemble and prepare information for each system, subsystem, and piece of equipment not part of a system.
 - 2. Prepare a separate manual for each system and subsystem, in the form of an instructional manual for use by Owner's operating personnel.
 - B. Content: For each system, subsystem, and piece of equipment not part of a system, include source information, manufacturers' maintenance documentation, maintenance procedures, maintenance

and service schedules, spare parts list and source information, maintenance service contracts, and warranties and bonds as described below.

- C. Source Information: List each system, subsystem, and piece of equipment included in manual, identified by product name and arranged to match manual's table of contents. For each product, list name, address, and telephone number of Installer or supplier and maintenance service agent, and cross-reference Specification Section number and title in Project Manual and Drawing or schedule designation or identifier where applicable.
- D. Manufacturers' Maintenance Documentation: Include the following information for each component part or piece of equipment:
 - 1. Standard maintenance instructions and bulletins; include only sheets pertinent to product or component installed. Mark each sheet to identify each product or component incorporated into Work. If data include more than 1 item in a tabular format, identify each item using appropriate references from Contract Documents. Identify data applicable to Work and delete references to information not applicable.
 - a. Prepare supplementary text if manufacturers' standard printed data are not available and where information is necessary for proper operation and maintenance of equipment or systems.
 - 2. Drawings, diagrams, and instructions required for maintenance, including disassembly and component removal, replacement, and assembly.
 - 3. Identification and nomenclature of parts and components.
 - 4. List of items recommended to be stocked as spare parts.
- E. Maintenance Procedures: Include the following information and items that detail essential maintenance procedures:
 - 1. Test and inspection instructions.
 - 2. Troubleshooting guide.
 - 3. Precautions against improper maintenance.
 - 4. Disassembly; component removal, repair, and replacement; and reassembly instructions.
 - 5. Aligning, adjusting, and checking instructions.
 - 6. Demonstration and training video recording, if available.
- F. Maintenance and Service Schedules: Include service and lubrication requirements, list of required lubricants for equipment, and separate schedules for preventive and routine maintenance and service with standard time allotment.
 - 1. Scheduled Maintenance and Service: Tabulate actions for daily, weekly, monthly, quarterly, semiannual, and annual frequencies.
 - 2. Maintenance and Service Record: Include manufacturers' forms for recording maintenance.
- G. Spare Parts List and Source Information: Include lists of replacement and repair parts, with parts identified and cross-referenced to manufacturers' maintenance documentation and local sources of maintenance materials and related services.
- H. Maintenance Service Contracts: Include copies of maintenance agreements with name and telephone number of service agent.
- I. Warranties and Bonds: Include copies of warranties and bonds and lists of circumstances and conditions that would affect validity of warranties or bonds.
 - 1. Include procedures to follow and required notifications for warranty claims.
- J. Drawings: Prepare drawings supplementing manufacturers' printed data to illustrate relationship of component parts of equipment and systems and to illustrate control sequence and flow diagrams. Coordinate these drawings with information contained in record Drawings to ensure correct illustration of completed installation.
 - 1. Do not use original Project record documents as part of maintenance manuals.

1.11 PRODUCT MAINTENANCE MANUALS

- A. Product Maintenance Manual: Assemble a complete set of maintenance data indicating care and maintenance of each product, material, and finish incorporated into Work.
- B. Content: Organize manual into a separate section for each product, material, and finish. Include source information, product information, maintenance procedures, repair materials and sources, and warranties and bonds, as described below.
- C. Source Information: List each product included in manual, identified by product name and arranged to match manual's table of contents. For each product, list name, address, and telephone number of Installer or supplier and maintenance service agent, and cross-reference Specification Section number and title and Drawing or schedule designation or identifier where applicable.
- D. Product Information : Include the following, as applicable:
 - 1. Product name and model number.
 - 2. Manufacturer's name.
 - 3. Color, pattern, and texture.
 - 4. Material and chemical composition.
 - 5. Reordering information for specially manufactured products.
- E. Maintenance Procedures: Include manufacturer's written recommendations and the following:
 - 1. Inspection procedures.
 - 2. Types of cleaning agents to be used and methods of cleaning.
 - 3. List of cleaning agents and methods of cleaning detrimental to product.
 - 4. Schedule for routine cleaning and maintenance.
 - 5. Repair instructions.
- F. Repair Materials and Sources: Include lists of materials and local sources of materials and related services.
- G. Warranties and Bonds: Include copies of warranties and bonds and lists of circumstances and conditions that would affect validity of warranties or bonds.
 - 1. Include procedures to follow and required notifications for warranty claims.

PART 2 - PRODUCTS (NOT USED)

PART 3 - EXECUTION (NOT USED)

END OF SECTION 017823

SECTION 017839
PROJECT RECORD DOCUMENTS

PART 1 - GENERAL

1.1 SUMMARY

- A. Section includes administrative and procedural requirements for Project record documents, including the following:
 - 1. Record Drawings.
 - 2. Record Specifications.
 - 3. Record Product Data.
 - 4. Miscellaneous record submittals.

1.2 CLOSEOUT SUBMITTALS

- A. Comply with requirements for Digital Information Management System as specified in Section 013100 – Project Management and Coordination for submittals of Project record documents and use of Architect’s digital data files. Submit record documents in the following formats:
 - 1. Record Drawings, Specifications, and Product Data: Annotated PDF electronic files of types of Document required unless indicated otherwise. Assemble each type of record document into electronically-indexed composite file.
 - 2. Record Digital Data Files: Digital data software as indicated in Document 005433 – Digital Data Licensing Agreement or annotated PDF electronic file with comment function enabled.
 - a. Record markups in layers separate from Architect’s data file layer information.
- B. Record Drawings: Submit copies of record Drawings as follows:
 - 1. Initial Submittal: Annotated PDF electronic files of scanned record prints or record digital data files.
 - a. Architect will indicate whether general scope of changes, additional information recorded, and quality of drafting are acceptable.
 - 2. Final Submittal: Annotated PDF electronic files of scanned record prints or record digital data files.
 - a. Submit each drawing file, whether or not changes and additional information were recorded.
- C. Record Specifications: Submit annotated PDF electronic files of Project's Specifications, including addenda and contract modifications.
- D. Record Product Data: Submit annotated PDF electronic files and directories of each submittal.
 - 1. Where record Product Data are required as part of operation and maintenance manuals, submit duplicate marked-up Product Data as a component of manual.
- E. Miscellaneous Record Submittals: See other Specification Sections for miscellaneous record-keeping requirements and submittals in connection with various construction activities. Submit annotated PDF electronic files and directories of each submittal.
- F. Reports: Submit written report indicating items incorporated into Project record documents concurrent with progress of Work, including revisions, concealed conditions, field changes, product selections, and other notations incorporated.

1.3 RECORD DRAWINGS

- A. Record Prints: Maintain 1 set of marked-up paper copies of Contract Drawings and Shop Drawings, incorporating new and revised drawings as modifications are issued.

1. Preparation: Mark record prints to show actual installation where installation varies from that shown originally. Require individual or entity who obtained record data, whether individual or entity is Installer, Subcontractor, or similar entity, to provide information for preparation of corresponding marked-up record prints.
 - a. Give particular attention to information on concealed elements that would be difficult to identify or measure and record later.
 - b. Accurately record information in an acceptable drawing technique.
 - c. Record data as soon as possible after obtaining it.
 - d. Record and check markup before enclosing concealed installations.
 - e. Cross-reference record prints to corresponding photographic documentation.
 2. Content: Types of items requiring marking include the following:
 - a. Dimensional changes to Drawings.
 - b. Revisions to details shown on Drawings.
 - c. Depths of foundations.
 - d. Locations and depths of underground utilities.
 - e. Revisions to routing of piping and conduits.
 - f. Revisions to electrical circuitry.
 - g. Actual equipment locations.
 - h. Duct size and routing.
 - i. Locations of concealed internal utilities.
 - j. Changes made by Change Order or Construction Change Directive.
 - k. Changes made following Architect's written orders.
 - l. Details not on original Contract Drawings.
 - m. Field records for variable and concealed conditions.
 - n. Record information on Work that is shown only schematically.
 3. Mark Contract Drawings and Shop Drawings completely and accurately. Use personnel proficient at recording graphic information in production of marked-up record prints.
 4. Mark record sets with erasable, red-colored pencil. Use other colors to distinguish between changes for different categories of Work at same location.
 5. Mark important additional information that was either shown schematically or omitted from original Drawings.
 6. Note Construction Change Directive numbers, alternate numbers, Change Order numbers, and similar identification, where applicable.
- B. Record Digital Data Files: Immediately before inspection for Certificate of Substantial Completion, review marked-up record prints with Architect. When authorized, prepare a full set of corrected digital data files of Contract Drawings, as follows:
1. **[Format: Same digital data software program, version, and operating system as original Contract Drawings.]**
 2. Format: Annotated PDF electronic file with comment function enabled.
 3. Incorporate changes and additional information previously marked on record prints. Delete, redraw, and add details and notations where applicable.
 4. Refer instances of uncertainty to Architect for resolution.
 5. Architect will furnish Contractor with 1 set of digital data files of Contract Drawings for use in recording information.
 - a. See Section 013100 Project Management and Coordination for requirements related to use of Architect's digital data files.
 - b. Architect will provide data file layer information. Record markups in separate layers.
- C. Format: Identify and date each record Drawing; include designation "PROJECT RECORD DRAWING" in a prominent location.
1. Format: Annotated PDF electronic file with comment function enabled.
 2. Record Digital Data Files: Organize digital data information into separate electronic files that correspond to each sheet of Contract Drawings. Name each file with sheet identification. Include identification in each digital data file.

3. Identification : As follows:
 - a. Project name.
 - b. Date.
 - c. Designation "PROJECT RECORD DRAWINGS."
 - d. Name of Architect.
 - e. Name of Contractor.

1.4 RECORD SPECIFICATIONS

- A. Preparation: Mark Specifications to indicate actual product installation where installation varies from that indicated in Specifications, addenda, and Contract modifications.
 1. Give particular attention to information on concealed products and installations that cannot be readily identified and recorded later.
 2. Mark copy with proprietary name and model number of products, materials, and equipment furnished, including substitutions and product options selected.
 3. Record name of manufacturer, supplier, Installer, and other information necessary to provide a record of selections made.
 4. For each principal product, indicate whether record Product Data has been submitted in operation and maintenance manuals instead of submitted as record Product Data.
 5. Note related Change Orders, record Product Data, and record Drawings where applicable.
- B. Format: Submit record Specifications as annotated PDF electronic file.

1.5 RECORD PRODUCT DATA

- A. Recording: Maintain 1 copy of each submittal during construction period for Project record document purposes. Post changes and revisions to Project record documents as they occur; do not wait until end of Project.
- B. Preparation: Mark Product Data to indicate actual product installation where installation varies substantially from that indicated in Product Data submittal.
 1. Give particular attention to information on concealed products and installations that cannot be readily identified and recorded later.
 2. Include significant changes in product delivered to Project site and changes in manufacturer's written instructions for installation.
 3. Note related Change Orders, record Specifications, and record Drawings where applicable.
- C. Format: Submit record Product Data as annotated PDF electronic file.
 1. Include record Product Data directory organized by Specification Section number and title, electronically linked to each item of record Product Data.

1.6 MISCELLANEOUS RECORD SUBMITTALS

- A. Assemble miscellaneous records required by other Specification Sections for miscellaneous record keeping and submittal in connection with actual performance of Work. Bind or file miscellaneous records and identify each, ready for continued use and reference.
- B. Format: Submit miscellaneous record submittals as PDF electronic file.
 1. Include miscellaneous record submittals directory organized by Specification Section number and title, electronically linked to each item of miscellaneous record submittals.

1.7 MAINTENANCE OF RECORD DOCUMENTS

- A. Maintenance of Record Documents: Store record documents in field office apart from Contract Documents used for construction. Do not use Project record documents for construction purposes. Maintain record documents in good order and in a clean, dry, legible condition, protected from

deterioration and loss. Provide access to Project record documents for Architect's reference during normal working hours.

PART 2 - PRODUCTS (NOT USED)

PART 3 - EXECUTION (NOT USED)

END OF SECTION 017839

SECTION 017900
DEMONSTRATION AND TRAINING

PART 1 - GENERAL

1.1 SUMMARY

- A. Section Includes:
1. Administrative and procedural requirements for instructing Owner's personnel, including the following:
 - a. Instruction in operation and maintenance of systems, subsystems, and equipment.

1.2 ADMINISTRATIVE REQUIREMENTS

- A. Coordination:
1. Coordinate instruction schedule with Owner's operations. Adjust schedule as required to minimize disrupting Owner's operations and to ensure availability of Owner's personnel.
 2. Coordinate instructors, including providing notification of dates, times, length of instruction time, and course content.
 3. Coordinate content of training modules with content of approved emergency, operation, and maintenance manuals. Do not submit instruction program until operation and maintenance data have been reviewed and approved by Architect.
- B. Pre-Instruction Meeting: Conduct meeting at Project site. Review methods and procedures related to demonstration and training including the following:
1. Inspect and discuss locations and other facilities required for instruction.
 2. Review and finalize instruction schedule and verify availability of educational materials, instructors' personnel, audiovisual equipment, and facilities needed to avoid delays.
 3. Review required content of instruction.
 4. For instruction that must occur outside, review weather and forecasted weather conditions and procedures to follow if conditions are unfavorable.

1.3 QUALITY ASSURANCE

- A. Facilitator Qualifications: A firm or individual experienced in training or educating maintenance personnel in a training program similar in content and extent to that indicated for this Project, and whose work has resulted in training or education with a record of successful learning performance.
- B. Instructor Qualifications: A factory-authorized service representative knowledgeable about the Project and experienced in operation and maintenance procedures and training.

1.4 INSTRUCTION PROGRAM

- A. Program Structure: Develop an instruction program that includes individual training modules for each system and for equipment not part of a system, as required by individual Specification Sections.
1. Training Hours: Schedule the following minimum number of hours for training:
 - a. Building Automation System: 16 hours.
 - b. Fire Alarm System: 4 hours.
 - c. Security/Access Control System: 4 hours.
 - d. HVAC Systems and Controls: Number of hours as stipulated in Owner/Contractor agreement.
 2. Training Modules: For each module, include instruction for the following as applicable to the system, equipment, or component:
 - a. Basis of System Design, Operational Requirements, and Criteria: Include the following:

- 1) System, subsystem, and equipment descriptions.
 - 2) Performance and design criteria if Contractor is delegated design responsibility.
 - 3) Operating standards.
 - 4) Regulatory requirements.
 - 5) Equipment function.
 - 6) Operating characteristics.
 - 7) Limiting conditions.
 - 8) Performance curves.
- b. Documentation: Review the following items in detail:
- 1) Emergency manuals.
 - 2) Systems and equipment operation manuals.
 - 3) Systems and equipment maintenance manuals.
 - 4) Product maintenance manuals.
 - 5) Project Record Documents.
 - 6) Identification systems.
 - 7) Warranties and bonds.
 - 8) Maintenance service agreements and similar continuing commitments.
- c. Emergencies: Include the following, as applicable:
- 1) Instructions on meaning of warnings, trouble indications, and error messages.
 - 2) Instructions on stopping.
 - 3) Shutdown instructions for each type of emergency.
 - 4) Operating instructions for conditions outside of normal operating limits.
 - 5) Sequences for electric or electronic systems.
 - 6) Special operating instructions and procedures.
- d. Operations: Include the following, as applicable:
- 1) Startup procedures.
 - 2) Equipment or system break-in procedures.
 - 3) Routine and normal operating instructions.
 - 4) Regulation and control procedures.
 - 5) Control sequences.
 - 6) Safety procedures.
 - 7) Instructions on stopping.
 - 8) Normal shutdown instructions.
 - 9) Operating procedures for emergencies.
 - 10) Operating procedures for system, subsystem, or equipment failure.
 - 11) Seasonal and weekend operating instructions.
 - 12) Required sequences for electric or electronic systems.
 - 13) Special operating instructions and procedures.
- e. Adjustments: Include the following:
- 1) Alignments.
 - 2) Checking adjustments.
 - 3) Noise and vibration adjustments.
 - 4) Economy and efficiency adjustments.
- f. Troubleshooting: Include the following:
- 1) Diagnostic instructions.
 - 2) Test and inspection procedures.
- g. Maintenance: Include the following:
- 1) Inspection procedures.
 - 2) Types of cleaning agents to be used and methods of cleaning.
 - 3) List of cleaning agents and methods of cleaning detrimental to product.
 - 4) Procedures for routine cleaning.
 - 5) Procedures for preventive maintenance.
 - 6) Procedures for routine maintenance.
 - 7) Instruction on use of special tools.
- h. Repairs: Include the following:

- 1) Diagnosis instructions.
- 2) Repair instructions.
- 3) Disassembly; component removal, repair, and replacement; and reassembly instructions.
- 4) Instructions for identifying parts and components.
- 5) Review of spare parts needed for operation and maintenance.

1.5 PREPARATION

- A. Assemble educational materials necessary for instruction, including documentation and training module. Assemble training modules into a training manual organized in coordination with requirements in Section 017823 – Operation and Maintenance Data.
- B. Set up instructional equipment at instruction locations.

1.6 INSTRUCTION

- A. Facilitator: Engage a qualified facilitator to prepare instruction program and training modules, to coordinate instructors, and to coordinate between Contractor and Owner for number of participants, instruction times, and location.
- B. Engage qualified instructors to instruct Owner's personnel to adjust, operate, and maintain systems, subsystems, and equipment not part of a system.
- C. Scheduling: Provide instruction at mutually agreed-on times. For equipment that requires seasonal operation, provide similar instruction at start of each season.
 1. Schedule training with Owner minimum of 14 days prior to Substantial Completion.
- D. Training Location and Reference Material: Conduct training on-site in completed and fully operational facility using actual equipment in-place. Conduct training using final operation and maintenance data submittals.
- E. Cleanup: Collect used and leftover educational materials and remove from Project site. Remove instructional equipment. Restore systems and equipment to condition existing before initial training use.

PART 2 - PRODUCTS (NOT USED)

PART 3 - EXECUTION (NOT USED)

END OF SECTION 017900

SECTION 018113
SUSTAINABLE DESIGN REQUIREMENTS

PART 1 - GENERAL

1.1 SUMMARY

A. Section Includes:

1. Administrative and procedural requirements necessary to obtain certification for Washington State Department of Commerce Evergreen Sustainable Development Standard, version 3.01.
2. A copy of Project ESDS rating systems checklist is attached at end of this Section for a summary of credits specific to Work. This checklist indicates specific requirements that will be implemented on this Project.
 - a. Ratings systems checklist is for informational use only.

B. Related Requirements:

1. Individual Specification Sections in Divisions 02 through 33 for requirements specific to Work of each of those Sections.

1.2 REFERENCES

A. Evergreen Sustainable Development Standard Criteria v3.01:

1. <http://www.commerce.wa.gov/wp-content/uploads/2018/03/hfu-esds-v3.0.1.pdf>.

1.3 DEFINITIONS

- A. Evergreen Sustainable Development Standard (ESDS): An environmental building program of Washington State Department of Commerce. ESDS Criteria promote public health, energy conservation, operational savings, and sustainable building practices in affordable housing design.
- B. IEQ: Indoor Environmental Quality.
- C. Prerequisite: Requirements that shall be met in order to achieve ESDS Certification. Noncompliance with any prerequisite may be cause for failure of Certification.
- D. Rapidly Renewable Materials: Materials made from plants that are typically harvested within a 10 year or shorter cycle. Rapidly renewable materials include products made from bamboo, cotton, flax, jute, straw, sunflower seed hulls, vegetable oils, and wool.
- E. Regionally Extracted, Harvested, or Recovered Materials: Materials that are extracted, harvested, or recovered and manufactured within a radius of 500 miles from Project site.
- F. Regionally Manufactured Materials: Materials that are manufactured within a radius of 500 miles from Project location.

1.4 CERTIFICATION AND DOCUMENTATION

- A. Evergreen Certification: Owner will designate a Sustainable Development Project Manager as the agent regarding the implementation of the Evergreen Sustainable Development Standard in Project. This person will have the following responsibilities:
 1. Know Project plans and understand the specs for all of the ESDS measures in Project;
 2. Communicate with Housing Trust Fund staff regarding the Evergreen Project Plan, its implementation, and any issues that may emerge during development related to it;
 3. Communicate progress, coordinate site visits, and facilitate verification and quality control with the third party verifier.

4. Oversee the development process to make sure that the ESDS features are implemented and correctly installed, and troubleshoot any ESDS problems with the GC/CM.
- B. The Sustainable Development Project Manager will communicate the construction schedule and its status and arrange the timing of the on-site inspections corresponding to the readiness of the Evergreen features to be reviewed with the 3rd party verifier.
- C. Maintain applicable Project records to be made available to Sustainable Development Project Manager and Third Party Verifier. A third party verifier will conduct on-site inspections in a consistent, fair, and transparent manner, to verify the correct implementation of ESDS features without holding up construction. The Sustainable Development Project Manager, Third Party Verifier and the GC/CM are encouraged to communicate early and cooperate often. Whenever possible, ESDS on-site inspections shall be scheduled with draw inspections.

PART 2 - PRODUCTS

2.1 MATERIALS

- A. Provide products and procedures necessary to obtain LEED credits indicated as Contractor's responsibility. Although other Sections may specify some requirements that contribute to these LEED credits, Contractor shall provide additional materials and procedures necessary to obtain LEED credits indicated.

2.2 DESCRIPTION

- A. Evergreen Sustainable Development Standard applies to buildings and site Work.
- B. To be eligible for grants or loans from WA State Housing Trust Fund (HTF), Project shall comply with mandatory provisions of Evergreen Sustainable Development criteria. In addition, new construction shall earn 50 points from Optional Criteria.
- C. Owner intends to achieve mandatory requirements and 56.5 points from optional criteria.

2.3 CONTRACTOR RESPONSIBILITIES

- A. Become familiar with sustainable design requirement programs to determine which relevant credits for this Project are influenced by their work, and to meet requirements of those Sections of Project.
 1. Some credits may be modified, removed, or added during course of construction as required to meet ratings as required by Owner.
 2. Responsibility column indicates firm responsible for completing submittal documents and providing back-up data.
- B. Integrate sustainable construction procedures into Work as required to meet or exceed ESDS certification.
 1. Satisfy mandatory prerequisites and credits / criteria as noted in the checklists applicable to Work of this Contact.
 - a. Coordinate and assist with documentation for certification.
 - b. Final rating systems submittals in electronic format for inclusion in certification application to WA Department of Commerce.
 - 1) Evergreen hardcopy binder on site with associated hardcopy backup
 2. **[Substitutions: Conform to provisions of Division 01 Section Substitution Procedures]**
- C. Designate a Contractor Sustainability Representative. Contractor Sustainability Representative shall:
 1. Implement, coordinate, and document specific ESDS requirements.
 2. Attend sustainable rating systems related meetings during construction.
 3. Be present on site during times that sustainable rating systems related Work is in progress.
 4. Coordinate inspections by ESDS third party verifier.

5. Maintain ESDS Project Binder at Project site.
- D. Maintain copies at Project site construction office of:
 1. Evergreen Sustainable Development Standard, version 3.0.1.
- E. Arrange and conduct Sustainability certification review meetings at least once a month.
 1. Combine with Project's Owner-Contractor-Architect meetings.
- F. **[Refer to Submittal Data Form at end of this Section]**. Return this form as part of a complete submittal package. If Contractor prefers to use their own formatted form for use during the entire duration of Project, submit the revised Submittal Form for review and acceptance prior to the first submittal transmittal.
 1. Attach manufacturer's literature that identifies the type and percentage of recycled content information supplied in the Submittal Data Form.
 2. Attach manufacturer's literature that identifies the locations of the manufacture and the location of the material harvest information supplied in the Submittal Data Form.
 3. Attach MSDS and third party certification for VOC information supplied in the Submittal Data Form.

PART 3 - EXECUTION

3.1 NONSMOKING BUILDING

- A. Smoking is not permitted within building or within 25 feet of entrances, operable windows, or outdoor-air intakes during and after construction.
- B. Set aside a designated remote smoking area.

3.2 CONSTRUCTION WASTE MANAGEMENT

- A. Comply with Section 017419 – Construction Waste Management and Disposal.
- B. **[No demolition or construction materials shall leave site untracked or prior to approved CWM Plan. See Division 01 Section Construction Waste Management and Disposal for more information. This includes mechanical and electrical items.]**

3.3 COMMISSIONING

- A. Comply with requirements in Section 019113 – General Commissioning Requirements.

END OF SECTION 018113

Evergreen Sustainable Development Standard v3.0 Checklist

Project Name: **Everett Housing Authority - Baker Heights Development**

Site Name: _____

Site Region:

Site Activity:

Design Element: Integrative Process

Criterion #	Criterion Title	Requirement Type/Optional Points	Points
1.1A	Integrative Process & Green Development Plan	Mandatory	x
1.1B	Integrative Process - Advanced Tools	0,2,4,6,8 or 10	4
1.2	Universal Design	up to 3	0
1.3A	Performance Verification	Mandatory	x
1.3B	Commissioning	up to 12 (2 point increments)	6
1.4	Socially Sustainable Living Patterns	0,3 or 6	3
Section 1 SUBTOTAL			13

Design Element: Location & Neighborhood Fabric

Criterion #	Criterion Title	Requirement Type/Optional Points	Points
2.1	Site Protection	Mandatory	x
2.2	Connections to Existing Development & Infrastructure	Mandatory	X
2.3	Compact Development	Mandatory	x
2.4	Maximizing Density	0 or 5	0
2.5	Access to Services & Public Transportation	Mandatory, +5	5
2.6	Preservation of & Access to Open Space	Mandatory	x
2.7A	Walkable Neighborhoods-Sidewalks & Pathways	Mandatory	x
2.7B	Walkable neighborhoods - Connections to Surrounding Neighborhood	0,3 or 5 -Tribal Only	n/a
2.8	Improving Connectivity to the Community	0 or 2	0
2.9	Greyfield, Brownfield or Adaptive Reuse Site	0 or 5	5
2.10	Access to Fresh, Local Foods	0 or 3	3
Section 2 SUBTOTAL			13

Design Element: Site Improvements

Criterion #	Criterion Title	Requirement Type/Optional Points	Points
3.1	Environmental Remediation	Mandatory	x
3.2	Erosion & Sedimentation Control	Mandatory	x
3.3a	Landscaping	Mandatory, if providing Landscaping	x
3.3b	Landscaping	0 or 5	5
3.3c	Landscaping-Significant Trees	up to 5	0
3.4	Efficient Irrigation	Mandatory, if installing irrigation	x
3.5	Surface Water Management	0,2,4 or 6	2
3.6	Storm Drain Labels	Mandatory	x
Section 3 SUBTOTAL			7

Design Element: Water Conservation

Criterion #	Criterion Title	Requirement Type/Optional Points	Points
4.1A	Water-Conserving Fixtures	Mandatory	x
4.1B	Advanced Water-Conserving Fixtures	up to 6, must also achieve 4.4	3
4.2	Water Metering	0 or 2	0
4.3	Water Reuse	0,1,2,4,6,8,10 or 12	0
4.4	Efficient Plumbing Layout & Design	0 or 7	7
Section 4 SUBTOTAL			10

Design Element: Energy Efficiency

Criterion #	Criterion Title	Requirement Type/Optional Points	Points
5.1A	Building Performance Standard - New Construction	Mandatory	x
5.1B	Building Performance Standard - Rehab	n/a	
5.2A	Additional Reduction in Energy Use - New Construction	5 to 25 (5 point increments)	5
5.2B	Additional Reduction in Energy Use - Rehab	n/a	
5.3	Shading for South Facing Windows	0,1,2,3 or 4	0
5.4	EnergyStar Appliances	Mandatory, if providing appliances	x
5.5	Central Laundry	0 or 3	0
5.6	Efficient Lighting	Mandatory	x
5.7A	Electricity Meter - New Construction	Mandatory	x
5.7B	Electricity Meter - Rehab	n/a	
5.8A	Renewable Energy	n/a	
5.8B	Photovoltaic/Solar Hot Water Ready	0 or 1	1
5.8C	Solar Water Heating	n/a	
5.9	Domestic Water Heating	Mandatory	x
5.10	Domestic Water Heating	n/a	
5.11	Performance Tested Building Air Sealing	n/a	
5.12	Performance Tested Duct Sealing	n/a	
5.13	Space Heating & Cooling Equipment Replacement	n/a	
Section 5 SUBTOTAL			6

Design Element: Materials

Criterion #	Criterion Title	Requirement Type/Optional Points	Points
6.1	Low/No VOC Paints & Primers	Mandatory	x
6.2	Low/No VOC Adhesives & Sealants	Mandatory	x
6.3	Construction Waste Management	up to 5	5
6.4	Environmentally Preferable Materials	up to 10 (0.5 increments)	2
6.5A	Reduced Heat-Island Effect: Roofing	0 or 2	0
6.5B	Reduced Heat-Island Effect: Paving	0 or 2, if paving	0
6.6	Socially Sustainable Products	up to 3	1
Section 6 SUBTOTAL			8

Design Element: Healthy Living Environment

Criterion #	Criterion Title	Requirement Type/Optional Points	Points
7.1	Composite Wood Products that Emit Low/No Formaldehyde	Mandatory	x
7.2A	Healthy Flooring Materials	Mandatory, if providing flooring materials	x
7.2B	Healthy Flooring Materials	0 or 6	0
7.3A	Exhaust Fans-Bathroom	Mandatory	x
7.3B	Exhaust Fans-Bathroom	n/a	
7.4A	Exhaust Fans-Kitchen	Mandatory	x
7.4B	Exhaust Fans-Kitchen	n/a	
7.5	Ventilation	Mandatory	x
7.6	Clothes Dryer Exhaust	Mandatory	x
7.7	Combustion Equipment	Mandatory	x
7.8	Mold Prevention: Surfaces	Mandatory	x
7.9	Mold Prevention: Tub & Shower Enclosures	Mandatory	x
7.10	Vapor Barrier Strategies	Mandatory	x
7.11	Radon Mitigation	Mandatory	x
7.12	Water Drainage	Mandatory	x
7.13A	Enhanced Building Envelope Design	Mandatory	x
7.13B	Enhanced Building Envelope Design	0,2,3,4,5,6,7 or 8	2
7.14	Garage Isolation	Mandatory	n/a
7.15	Integrated Pest Management	Mandatory	x
7.16	Lead-Safe Work Practices	Mandatory	x
7.17	Smoke-Free Bulding	Mandatory	x
Section 7 SUBTOTAL			2

Design Element: Operations, Maintenance & Resident Management

Criterion #	Criterion Title	Requirement Type/Optional Points	Points
8.1A	Building Maintenance Manual & Unit Turnover Plan	Mandatory	x
8.1B	O&M Instructions for Maintenance Staff	0 or 7	7
8.2	Emergency Management Plan	Mandatory for Multifamily Projects	x
8.3	Resident Manual & Orientation Example	Mandatory	x
8.4	Project Data Collection	0,3,5 or 8	3
8.5	Educational Signage	Mandatory	x
Section 8 SUBTOTAL			10

Thresholds

In order to ensure that your project will pass the threshold for the Evergreen Sustainable Development Standard, we advise building in a "cushion" of 5-10 points above what is required.

New Construction projects must achieve 50 points
Rehab - Moderate and **Rehab - Substantial** projects must achieve 40 points

Section 1	13
Section 2	13
Section 3	7
Section 4	10
Section 5	6
Section 6	8
Section 7	2
Section 8	10
Overall Checklist Total	69

ESDS v3.0 Criteria	Method used to Satisfy Criterion	Instructions	Points
1.1a Integrative Process & Green Development Plan	See attached ESDS 1.1 Green Development Plan	(Mandatory) Attach the Green Development Plan	M
1.1b Integrative Process-Advanced Tools		(Up to 10) State the Option(s) chosen. In addition: <ul style="list-style-type: none"> • Option #1- Attach energy and water modeling documentation and a narrative explaining how these services informed decisions about design, construction and post-occupancy. • Option #2- Attach the life cycle cost analysis. Use the LCCA tool provided on ESDS websites. In addition, include a narrative detailing how the design team incorporated the use of the tool into their process, how, or if, design decisions were influenced by the process of using the tool, and suggestions for enhancements to the tool. • Option #3- State that a 25-year CNA was provided with your funding application. If not, provide the report. 	4
1.2 Universal Design	The site is located in the Residential 4 zoning district and is not within 300 feet of any known critical areas or wetlands and is not within the aquifer recharge boundary. See attached file ESDS 2.1 Site Protection - GIS Zoning.pdf	(up to 3) State which option was incorporated and list the features	0
1.3a Performance Verification	4.1a or 4.1b Water Conserving Fixtures - bag testing or bucket testing shower heads and faucets. The sample size will be a minimum of 15% of units spread across the project.	(Mandatory) State: <ol style="list-style-type: none"> (1) Which ESDS criterion required Performance Verification. (2) Construction documents include the Performance Verification requirements. (3) The installer has provided written verification that the systems operate as required, available on the jobsite. 	M
1.3b Commissioning	The following systems will be included in the commissioning plan - 5.2a - Domestic Water Heating (2pts of 2pts), 5.6 Lighting controls (2 pts of 2pts) and 5.8b HVAC (2pts of 2pts). These systems will appear in the final commissioning report and will be available for inspection upon request. The architect and MEP consultants will develop a Basis of Design that meets the Owner's Project Requirements at a minimum and the performance requirements established in 1.1. The commissioning requirements will be incorporated into the construction documents.	(up to 12) State: <ol style="list-style-type: none"> (1) Which applicable systems were included in the commissioning plan. (2) That a final commissioning report is available for inspection upon request. (3) The architect and MEP consultants have developed a Basis of Design (BOD) that meets the Owner's Project Requirements (at a minimum, the performance requirements established in 1.1); (4) Commissioning requirements have been incorporated into the construction documents. 	6
1.4 Socially Sustainable Living Patterns	Spaces and features were developed to create an inclusive sense of community and cultivate meaningful support networks through the use of wide exterior exit balconies and exterior stairs serving all units. Additionally, the project was designed to allow the interaction and engagement of all the units with common space and access to outdoor passive and active recreation through private internally focused spaces that are focused around a linear layout of terraced open space and play areas. The resident population participated in the sustainability of the project through a series of community meetings where the design team had the community place program pieces as a means to encourage them to take ownership in how they would like the buildings to interact and how they would navigate the site.	(up to 6) Option #1: attach a description of how the project design team intentionally developed spaces or features that help residents develop an inclusive sense of community and cultivate meaningful support networks. Describe the plan that on-site staff will follow to encourage residents to use the spaces as intended. Option #2: attach a description for how the resident population will participate in discussions regarding the sustainability of the project. Describe how the advisory board or governance structure will be formed, who will be responsible for managing the process, and how the resident population might participate.	3

2.1 Sensitive Site Protection	See attached ESDS 2.1 Site Protection	(Mandatory) Attach documentation from the local jurisdiction stating the zoning for the property, identification of any known critical areas or resource lands within 300 feet and any resulting development restrictions.	M
2.2 Connections to Existing Development & Infrastructure	See attached ESDS 2.2 Connections to Existing Development & Infrastructure	(Mandatory for Urban, 2 points for Rural) Attach a clear and detailed Site & Vicinity Map with explanations. Clearly label and indicate on the map the areas specific to this criterion.	M
2.3 Compact Development	See attached ESDS 2.4 Maximizing Density.pdf	(Mandatory) Attach the architect's density calculation and statement of correctness.	M
2.4 Maximizing Density	N/A	(5 points) Attach the architect's density calculation and statement of correctness.	X
2.5 Access to Services & Public Transportation	Option #1: Proximity to Services. See: ESDS 2.5 ACCESS TO SERVICES.pdf Option #2: Access to Public Transportation. See: ESDS 2.5 ACCESS TO TRANSPORTATION.pdf	(Mandatory and option for 5 points) State which option(s) chosen. Option #1: Attach a context map demonstrating that the center of the site is within the required walk distances of the required number of services. Google Maps offers a function to demonstrate walk distance. On Google Maps, go to "Directions" and select "Walk Directions" to obtain this information. Option #2: Attach a context map to demonstrate that the center of the site is within the required distance of transit options. Google Maps offers a function to demonstrate walk distance. On Google Maps, go to "Directions" and select "Walk Directions" to obtain this information.	5
2.6 Preservation of & Access to Open Space	See attached ESDS 2.6 Preservation of & Access to Open Space.pdf	(Mandatory) State the option chosen and how the design meets the requirement. Attach a clear and detailed Site & Vicinity Map and indicate on the map the areas designated as open space for residents. Open space does not include streets, roadways, or tenant private outdoor areas, or areas inaccessible to residents.	M
2.7a Walkable neighborhoods-sidewalks & pathways	See attached ESDS 2.7a Walkable neighborhoods-sidewalks & pathways.pdf	(Mandatory for Urban only) Attach a site map clearly illustrating the existing and proposed sidewalks and all-weather pathways and where they lead to.	M
2.7b Walkable neighborhoods-connections to surrounding neighborhood	N/A	(Rural & Tribal projects only, 3-5 points) State how many separate connections the project provides. Attach a site map demonstrating at least three separate connections to sidewalks or all-weather pathways in surrounding neighborhoods.	N/A
2.8 Improving Connectivity to the Community	N/A	(2 points) State which two measures have been used and describe the implementation plan. If choosing car-sharing services or bicycle racks/storage, attach a site map identifying the space that will dedicated for the amenities.	0
2.9 Greyfield, Brownfield or Adaptive Reuse Site	Currently a brownfield, the site as existing, consists of concrete-block residential structures dating to the post-WWII era. Site infrastructure and utilities also date from that era.	(5 points) Provide a description and explanation that confirms the type of site.	5
2.10 Access to Fresh, Local Foods	Option 3 - Proximity to Farmers Market (3pts of 3pts). Triangle Fruit Market and Rons Food Market are within .20 miles of the project site. See ESDS 2.5 Access to Services.pdf	(3 points) State which option the project provides. Attach a detailed plan of how the requirements have been met. If selecting Options 1a or 1b, attach a site map identifying the growing space.	3

3.1 Environmental Remediation	The most expedient option is to remove lead impacted, shallow soils nearby the office complex and one other parcel where concentrations were noted.	(Mandatory) State the conclusion of the ESA Phase 1.	M
3.2 Erosion & Sedimentation Control	As required by the City of Everett the project will incorporate Erosion and Sediment Control BMPs in accordance with Chapter 4 of Volume II of the Stormwater Management Manual. BMPs shall be provided to address each of the 13 elements cited in Section 2-3 within the City of Everett Design and Construction Standards.	(Mandatory) State which BMP or local controls have been incorporated into the construction and site development plans and contracts. The actual erosion measures that have been specifically be used on the site.	M
3.3a Landscaping	See ESDS 3.3a Landscaping.pdf	(Mandatory) Attach a landscape plan showing native plantings and their relation to the building(s). The map must clearly show 50% or more of the landscaped area as native and/or adaptive species.	M
3.3b Landscaping	See ESDS 3.3a Landscaping.pdf	(5 points) Attach a landscape plan showing native plantings and their relation to the building(s). The map must clearly show 100% or more of the landscaped area as native and/or adaptive species.	5
3.3c Landscaping- Significant Trees	N/A	(up to 5 points) State the number of trees and DBH of each. State that the project did not build within the drip line of the significant trees. Attach the arborist report which evaluates each significant tree's life expectancy, health, future maintenance needs and safety. Attach a brief explanation regarding the property maintenance plan for the significant trees, given the arborist report conclusions. Attach a landscape plan showing existing significant trees, which trees are being preserved, and their relation to the building(s).	0
3.4 Efficient Irrigation	All planting area irrigation systems shall: - Use only drip and/or bubbler irrigation systems. - Separately zone turf and each type of bedding area, based on watering needs. - Include a zone manifold and/or timer/controller that can be programmed to control the frequency, time of day and duration of irrigation for each watering zone to minimize evaporative losses while maintaining healthy plants and obeying local regulations and water-use guidance. - Include a moisture sensor controller or rain delay controller or weather-based irrigation controller designed to eliminate irrigation overwatering when plant needs are met by natural precipitation. -Use spray heads on steep slopes where drip irrigation would be ineffective. The spray heads shall have a minimum distribution uniformity (DU) of 0.7.	(Mandatory) State that drip and/or bubbler irrigation system has been used for all landscape planting beds and trees. State that turf and each type of bedding area has been separately zoned based on watering needs with a programmed zone manifold and/or timer/controller. State that a controller designed to eliminate irrigation overwatering has been installed.	M
3.5 Surface Water Management		(up to 6 points) Attach the precipitation data location used, the appropriate rainfall event size, a site plan showing the total generating surfaces and calculated area for the project, and describe design features that have been implemented to meet the requirements, with an affidavit affirming that the design is sized to accommodate the target rainfall event - from the qualified design professional responsible for the design calculations.	2
3.6 Storm Drain Labels	All storm drains and inlets will be labeled.	(Mandatory) State that you have labelled all storm drains and inlets.	M

4.1a Water-Conserving Features	Section 224000: Water Closet - 1.28 GPF, WaterSense Labeled. Meets MaP requirement of minimum 500g. Showerheads - 1.75 GPM, WaterSense Labeled. Lavatory Faucet -0.5 GPM, WaterSense Labeled. Kitchen Faucet - 1.5 GPM	(Mandatory) State the flow rates, WaterSense, and MaP performance for applicable fixtures that have been installed. State that a minimum of 15% of units have completed performance verification according to the requirements in ESDS 1.3a. Toilets – 1.28 GPF (gallons per flush) or less. WaterSense labeled with MaP test performance at minimum 500g, Urinals- 0.5 gpf or less, WaterSense labeled, Showerheads – 2.0 GPM (gallons per minute) or less, WaterSense labeled, Bathroom faucets – 1.5 GPM or less, WaterSense labeled, Kitchen faucets – 2.0 GPM or less	M
4.1b Advanced Water-Conserving Features	Section 224000: Toilet 1.28 > ESDS 1.1 gpf WaterSense(0 of 2pts) Shower 1.75 gpm WaterSense labled = ESDS 1.75 gpm WaterSense (2 of 2pts) Lav 0.5 gpm WaterSense labled = ESDS 0.5gpm WaterSense (1 of 1pt) Kitchen 2.0 gpm = ESDS 1.75gpm or less (0 of 1pt)	(up to 6 points) State the flow rates, WaterSense, and MaP performance for applicable fixtures that have been installed. State that a minimum of 15% of units have completed performance verification according to the requirements in ESDS 1.3a. State that the project complies with ESDS 4.4. Toilets – 1.1 GPF (gallons per flush) or less. or a toilet with dual flush, one of the options being less than 1 GPF, 500gWaterSense labeled, Showerheads – 1.75 GPM (gallons per minute) or less, WaterSense labeled, Bathroom faucets – 1 GPM or less, WaterSense labeled, Kitchen faucets – 1.75 GPM or less	3
4.2 Water Metering	N/A	(New Construction 2, Rehab 4) Attach a description of how sub-meter data will be tracked, who will be responsible for monitoring it, and how the data will be used (direct billing or back-charging residents for water/sewer costs, providing consumption feedback for conservation assistance, leak detection and isolation, etc.) For rehab only, if metering each dwelling unit is not feasible, attach an optimal measuring proposal.	0
4.3 Water Reuse	N/A	(up to 12 points) Option #1: State how the design meets the requirement; how these details have been communicated to the plumbing contractor; and how they have been verified as compliant at construction. Option #2: State the percentage of the project's water needs that have been supplied by rainwater and/or greywater. Also, attach an explanation of how the project's total water need was determined and describe the design features (including cistern sizing calculation) that have been implemented to achieve the stated percentage.	0
4.4 Efficient Plumbing Layout & Design	Plumbing layout and design meet requirements with recirculation pumps used to maintain a min water temperature of 110 degrees F in the main piping loop, piping located to expedite hot water service to any fixture and domestic hot water controlled by return water temp. All piping insulated as required by section C403.3.2.9 of the WSEC, as calculated and described on sheets P-001 and P-002.	(7 points) State how the design meets the requirement; how the details were communicated to the plumbing contractor: how proper installation has been confirmed.	7

5.1a Building Performance Standard - New Construction		(Mandatory) For Single Family Homes, duplexes, townhomes or multifamily buildings three stories or less: State the additional credit chosen from the 2015 WSEC Table R406.2, Energy Credits. OR Attach the 2015 WSEC section R405.3 Performance-based compliance cover sheet demonstrating an additional 7% reduction in energy use compared to code. Multifamily buildings greater than three stories: State the additional credit chosen from the 2015 WSEC C406—Additional efficiency package options. OR, Attach the 2015 WSEC section C407.3—Performance-based compliance cover sheet to demonstrate and additional 4 % reduction in energy use compared to the code.	M
5.1b Building Performance Standard -Rehab	Rehab Only	Rehab Only	
5.2a Additional Reduction in Energy Use - New Construction	N/A	(5-25 points) For the prescriptive energy credits approach, attach documentation showing the energy credits used to meet code and the added energy credits to achieve additional energy savings. For the performance based approach, use the analysis methodology required by code. Demonstrate that the proposed design will provide additional % reduction in energy use compared to code and ESDS 5a.	5
5.2b Additional Reduction in Energy Use - Rehab	Rehab Only	Rehab Only	
5.3 Shading for South Facing Windows	N/A	(4 points) Attach documentation that shading devices on the building provides the described solar access and shading. Include an illustration demonstrating shading at the required date and times.	0
5.4 EnergyStar Appliances	All clothes washers, dishwashers & refrigerators will be EnergyStar per specification Div 11, Section Residential Appliances	(Mandatory) State that all clothes washers, dishwashers & refrigerators are Energy Star. Do not send in product literature or spec sheets.	M
5.5 Central Laundry	N/A	(3 points) State that the project provides ENERGY STAR-labeled centralized laundry facilities and has not installed in-unit washers or dryers or hook-ups.	0
5.6 Efficient Lighting - Interior Units	Minimum 90% of lighting shall be fitted with Energy Star, high efficiency luminaires or lamps as specified on Luminaire Schedules- Electrical	(Mandatory) State that 90% of lighting has been fitted with LED luminaires or lamps. Do not send in product literature or spec sheets with the EPP.	M
5.7a Electricity Meter	Individual or a submetered electric meter will be installed for each individual unit.	(Mandatory) State that individual or a sub-metered electric meter has been installed for each individual unit.	M
5.7b Electricity Meter	Rehab Only	Rehab Only	
5.8a Renewable Energy	Rehab Only	Rehab Only	

5.8b Photovoltaic/Solar Hot Water Ready		(1 point) Explain the plan including orientation, unobstructed exposure, conduit route and location of terminations. Attach the design and engineering analysis that establishes the parameters of the installation that demonstrate the following: Orient buildings to permit access to sunlight, design and include south facing architectural elements on the roof for PV, reserve unobstructed roof areas where panels can be placed, run conduit from the prospective PV location to a central panel, as part of the general electrical work, and do not install wire inside the conduit until the photovoltaic panels are installed.	1
5.8c Solar Water Heating	Rehab Only	Rehab Only	
5.9 Domestic Water Heating		(Mandatory) State the type of fuel, tank size, energy factor, and standby loss as applicable. Do not send in product literature or spec sheets.	M
5.10 Domestic Water Heating	Rehab Only	Rehab Only	
5.11 Performance Tested Building Air Sealing	Rehab Only	Rehab Only	
5.12 Performance Tested Duct Sealing	Rehab Only	Rehab Only	
5.13 Space Heating & Cooling Equipment Replacement	Rehab Only	Rehab Only	
6.1 Low/No VOC Paints & Primers	All interior paints and primers will meet the standard.	(Mandatory) State that all interior paints and primers meet the standard.	M
6.2 Low/No VOC Adhesives & Sealants	Interior adhesives and sealants will comply with the most recent version of Rule 1168 of the South Coast Air Quality Management District, as indicated in the Section 079200 Joint Sealants 1.2 I. 1. a. and as noted in Div 01 Section Sustainable Design Requirements.	(Mandatory) State that all interior adhesives comply with the most recent version of Rule 1168 of the South Coast Air Quality Management District.	M
6.3 Construction Waste Management	Method #1 - Measured by percentage shall be used. Contractor shall provide a waste management plan that diverts at least 75% construction waste from the landfill (5 pts) and will comply with LEED-NC & LEED-H requirements likely exceeding 75%. Contractor submittal of the CW Plan will be available on the job site, specifying how reuseable / recyclable materials are diverted from the landfill and where each material goes. See specification Div 01 Section Construction Waste Management and Disposal.	(up to 5 points) State the method chosen and that the construction waste plan was available on the job site specifying how reusable/recyclable materials were to be redirected from the landfill and where each material was to go.	5
6.4 Environmentally Preferable Materials		(up to 10 points) Attach the list of environmentally preferable materials that have been used and note the specification requirement and/or the local production requirement.	2
6.5a Reduced Heat-Island Effect: Roofing	N/A	(2 points) State which option was chosen. Also attach roof map showing all roofing areas with the type of roof specified. Clearly label and indicate on the map the areas specific to this criterion.	0
6.5b Reduced Heat-Island Effect: Paving	N/A	(2 points) State the category of points chosen and provide performance testing documentation, calculations, and explanations. Attach a map of all paved areas showing the portion that will reduce the heat-island effect and the type of material.	0
6.6 Socially Sustainable Products		(up to 3 points) State the socially sustainable products that were used. Attach an explanation of each manufacturer, the product used in the project, and how they support a broader socially sustainable mission.	1

7.1 Composite Wood Products: No Added Urea Formaldehyde	N/A	(Mandatory) State that all particleboard, plywood, OSB, medium density fiberboard, cabinetry and any other applicable wood products contain no added urea-formaldehyde and/or will be compliant with CARB Phase 2.	X
7.2a Healthy Flooring Materials	N/A	(If providing floor coverings, Mandatory) State what floor coverings were used and where and that they meet the requirements of this criteria.	M
7.2b Healthy Flooring Materials	N/A	(6 points) State that in all rooms, carpet or flooring containing PVC or chlorine has not been installed.	0
7.3a Exhaust Fans-Bathroom	Fan shall be installed in bathroom and operate continuously at low speed 55 CFM and switch to high speed (80 CFM) when fan light is switched on. Fan shall return to low speed when light switch is deactivated. Public restroom fans to operate upon activation of the light switch or occupancy sensor. Fans will shut off after 5 minute delay.	(Mandatory) State Energy Star bathroom fans including how they are controlled.	M
7.3b Exhaust Fans-Bathroom	N/A	Moderate Rehab only	
7.4a Exhaust Fans-Kitchen	Energy Star Kitchen fans will be installed and vented to the outside.	(Mandatory) State that Energy Star kitchen fans were installed and vented to the outside.	M
7.4b Exhaust Fans-Kitchen	Energy Star Kitchen fans will be installed and vented to the outside.	(3 points) State that Energy Star kitchen fans were installed and vented to the outdoors.	M
7.5 Ventilation	Whole House Ventilation will be installed according to Section 403 of the 2015 WSEC. The fan's size, determination of size and location as shown and calculated on M-001 and M-002. Fan shall be installed in bathroom and operate continuously at low speed 55 CFM and switch to high speed (80 CFM) when fan light is switched on. Fan shall return to low speed when light switch is deactivated. Public restroom fans to operate upon activation of the light switch or occupancy sensor. Fans will shut off after 5 minute delay.	(Mandatory) State that whole-house ventilation has been installed according to section 403 of the 2015 WSEC. State the size of fan, how the size was determined, the location, and how it is controlled.	M
7.6 Clothes Dryer Exhaust	Clothes dryer exhaust has been designed to exhaust to the outdoors	(Mandatory) State that clothes dryers are exhausted to the exterior using rigid-type ductwork (from the connection point to the exterior exhaust), except for condensing and heat pump dryers, which must be plumbed to a drain.	M
7.7 Combustion Equipment		(Mandatory) State that there are direct power vented or combustion sealed fossil fuel fired water heaters when in the conditioned space.	M
7.8 Mold Prevention: Surfaces	There will be smooth, durable, cleanable, water-proof surfaces in wet areas. See floor plans and interior elevations for painted GWB, tub / shower surrounds, sheet flooring, and rubber base in wet areas.	(Mandatory) State that there are smooth, durable, cleanable, water-proof surfaces in all wet areas.	M
7.9 Mold Prevention: Tub & Shower Enclosures	One piece fiberglass surrounds provided	(Mandatory) State which materials for tub and shower enclosures have been used.	M
7.10 Vapor Barrier Strategies	Typical slab on grade floor type includes: 4 -5" CONCRETE SLAB 15 MIL REINFORCED VAPOR RETARDER 4" CAPILLARY BREAK MATERIAL This exceeds the requirement. See highlighted Dwgs.: A-605 Floor Type 'F01' There are no crawlspaces planned in the project.	(Mandatory for foundation work) State the vapor barrier strategies that were used in the project.	M
7.11 Radon Mitigation	Radon mitigations that will be followed are the following: Facilitate post testing and ensure documentation verification is reviewed by the third party verifier.	(Mandatory) State whether the project is in a high risk radon county. If so, continue with the following: For New Construction, state the list of radon mitigation measures that have been installed. For Rehabilitation, state that radon testing using the EPA protocols has been done and state type and duration of test. If radon testing shows 4 pCi/L or higher, state here the radon mitigation measures that were installed.	M

7.12 Water Drainage	All water drainage measures listed in this criterion will be followed.	(Mandatory) State that all water drainage measures listed in this criterion have been followed. Note: For rehab, all measures which apply to the scope of work are required.	M
7.13a Enhanced Building Envelope Design	The building envelope design will make it possible to remove and replace windows without compromising the performance of the building envelope.	(Mandatory) State that the building envelope design makes it possible to remove and replace windows without compromising the performance of the building envelope.	M
7.13b Enhanced Building Envelope Design		(up to 8 points for NC, up to 10 points for Substantial Rehab) State the option(s) chosen and how the objective has been achieved.	2
7.14 Garage Isolation	N/A	(Mandatory) State that there is a continuous air tight barrier between the living space and an attached garage, how it was achieved, and the number of placements of CO monitors as necessary.	M
7.15 Integrated Pest Management	Sealing of all penetrations will be done and include what materials were used to prevent pest and rodent entry.	(Mandatory) State that sealing of all penetrations was done and include what materials were used to prevent pest and rodent entry.	M
7.16 Lead-Safe Work Practices	N/A	(Mandatory) State the year when the buildings were constructed. For structures built before 1978, state that lead-safe work practices were followed. Also state that the contractor performing this was Renovation, Repair and Painting certified at a minimum.	M
7.17 Smoke-Free Building	A smoke-free policy (including e-cigarettes) in all common and individual living areas, including decks and patios, in unit leases and within 25 feet of building entries or ventilation intakes (including operable windows) will be implemented and enforced. The lease language will prohibit smoking in these locations and it is a violation of the lease to smoke. All aspects of the lease will be enforced by Property Management.	(Mandatory) State that a smoke-free policy (including e-cigarettes) in all common and individual living areas, including decks and patios, in unit leases and within 25 feet of building entries or ventilation intakes (including operable windows) has been implemented and enforced. Also state that the lease language prohibits smoking in these locations and that it is a violation of the lease to smoke. Provide a copy of the lease in the on-site binder.	M
8.1a Building Maintenance Manual & Unit Turnover Plan	A copy of the Building Maintenance Manual and the Unit Turnover Plan will be submitted to Commerce before the project is completed.	(Mandatory) State that a copy of the Building Maintenance Manual and the Unit Turnover Plan will be submitted to Commerce before the project is completed. State the estimated date of submittal. State the date the walk-through and orientation will be completed.	M
8.1b O&M Instructions for Maintenance Staff	A Building Maintenance Manual will be submitted by the Project Sponsor.	(7 points) State that the Building Operations and Maintenance instructions will be permanently affixed to the building. State that the requirements regarding the location, instructions and walk-through will be followed.	7
8.2 Emergency Management Plan	An Emergency Management Manual will be available for inspection upon request.	(Mandatory) State that the Emergency Management Manual is available for inspection upon request.	M
8.3 Resident Manual & Orientation	The resident manual will be available for inspection upon request. An orientation will be completed with new tenants as well as at turnover.	(Mandatory) State that the Resident Manual is available for inspection upon request. State how the orientations will be completed with new tenants and the plan for orientation at turnover.	M
8.4 Project Data Collection	EHA: To provide collection and monitoring of energy and water performance data. Glumac: Infrastructure to monitor energy use per unit has been included in the design. Owner team utilize provided structure to implement data collection plan. Included in plan will be utility release forms as required and making data available to Commerce on an annual basis.	(8 points) State which option chosen. State that the property management staff will collect and monitor project performance data on energy, water, and, if possible, healthy living environments for a minimum of five years.	3

8.5 Educational Signage	N/A	(Mandatory) State that educational signage and/or educational material is provided onsite.	M
TOTAL			69

EHA – Baker Heights Redevelopment
GGLO No. 2017033

Green Development Plan – Everett Housing Authority Baker Heights Redevelopment

Project Sponsor:
Everett Housing Authority

Mailing Address:
3107 Colby Avenue, Everett, WA 98201

Phone: (425)-258-922
Fax: (425)-303-1122
Email: stevey@evha.org

Project Name:
Everett Housing Authority – Baker Heights Redevelopment

Project Address:
BUILDING A – 2800 14th Street, Everett, WA 98201
BUILDING B - 2825 15th Street, Everett, WA 98201
BUILDING C - 2875 15th Street, Everett, WA 98201
BUILDING D - 2850 14th Street, Everett, WA 98201

Sustainable Development Manager:

Company Name:
Everett Housing Authority

Mailing Address:
3107 Colby Avenue, Everett, WA 98201

Project Team

	Firm	Primary Contact	Phone	Email
Architect	GGLO	Jon Hall	(206)-902-5508	jhall@gglo.com
Sustainability Advisor				
Landscape Architect	GGLO	Marieke Lacasse	(206)-902-5614	mlacasse@gglo.com
Civil Engineer	KPFF	Alberto Cisneros	(206)-926-0519	Alberto.cisneros@kpff.com
Mechanical, Electrical & Plumbing Engineer	Glumac	Scott Vollmoeller	(206)-262-1010 ext 360	svollmoeller@glumac.com
Contractor	CDK	Howard Treat	(425)-788-8441	htreat@cdkconstruction.com
Structural Engineer	Michael Nouwens Structural Consultants	Michael Nouwens	(206)-546-8446	michael@nouwens- structural.com

Baker Heights Redevelopment is a proposed housing development site on a portion of the larger Baker Heights Public Housing in North Everett, Washington. Sustainability goals for the site were established during the schematic design and design development process. The project will contain the following green development goals:

Green development goals:

- Integrative Design
- Location & Neighborhood Fabric
- Site Improvements
- Water Conservation
- Energy Efficiency
- Materials Beneficial to the Environment
- Healthy Living Environment
- Operations & Management

Integrated Design Process

A collaborative process with all design construction and owner representatives involved from the early project stages ensure sustainable design strategies are followed through the construction process. The whole project team is and will be aware of team goals throughout the design, bidding, and construction phases to reduce unexpected costs. Goals discussed and established include:

Pursuing cost-effective strategies for energy, water, materials, maintenance, and operations efficiency.

Meeting regulatory requirements of various project funders.

Pursuing sustainable strategies which can be leveraged for incentive funds.

Determine green building rating systems to pursue:

Evergreen Sustainable Development Standard

Site

The housing development is nested on the brow of a moderately sloping hillside facing East. The existing Baker Heights Public Housing continues to the north, though a proposal exists for Washington State University to redevelop some of the blocks to the north. To the South and East are mature single-family residential homes. To the West is the Baker Heights Community Center, the Everett Housing Authority's maintenance building, and the mid-rise Baker Heights Senior apartment building

Water Conservation

Native and drought tolerant plantings with drip irrigation will provide a lush landscape. Interior low flow plumbing fixtures will reduce water use by approximately 20% over conventional construction. Energy Star and Water Wise appliances will be installed to minimize water and energy use.

Energy Efficiency

Highly thermally efficient windows are installed in all areas. High efficiency water heaters and energy star appliances will be installed to reduce energy demand.

Materials Beneficial to the Environment

At least 75% of the construction and demolition waste will be recycled or salvaged reducing demand on landfills. Specified recycled content materials used in construction will include concrete and rebar, gypsum wall board, insulation, carpet and pad, siding, and metal flashings and trim. Locally sourced and produced materials will include siding, concrete, metal, lumber and paint.

Healthy Living Environment

Low VOC paint, sealants, adhesives and Green Label Plus carpet and pad will be used to minimize off-gassing and interior environment pollution. Energy star bathroom and kitchen fans will be installed to ensure proper ventilation and minimize potential for interior moisture and mold problems. The exterior siding will be installed with a rainscreen and air barrier strategy to minimize moisture infiltration and mold potential.

Operations and Management

On-site staff will be trained in all aspects of the buildings. Owner and occupant manuals will be developed for

EHA – Baker Heights Redevelopment
GGLO No. 2017033

understanding of building systems and procedures. New residents will also be provided with an orientation to understand the operations of their home.

City of Everett

R-4 Multifamily Zone

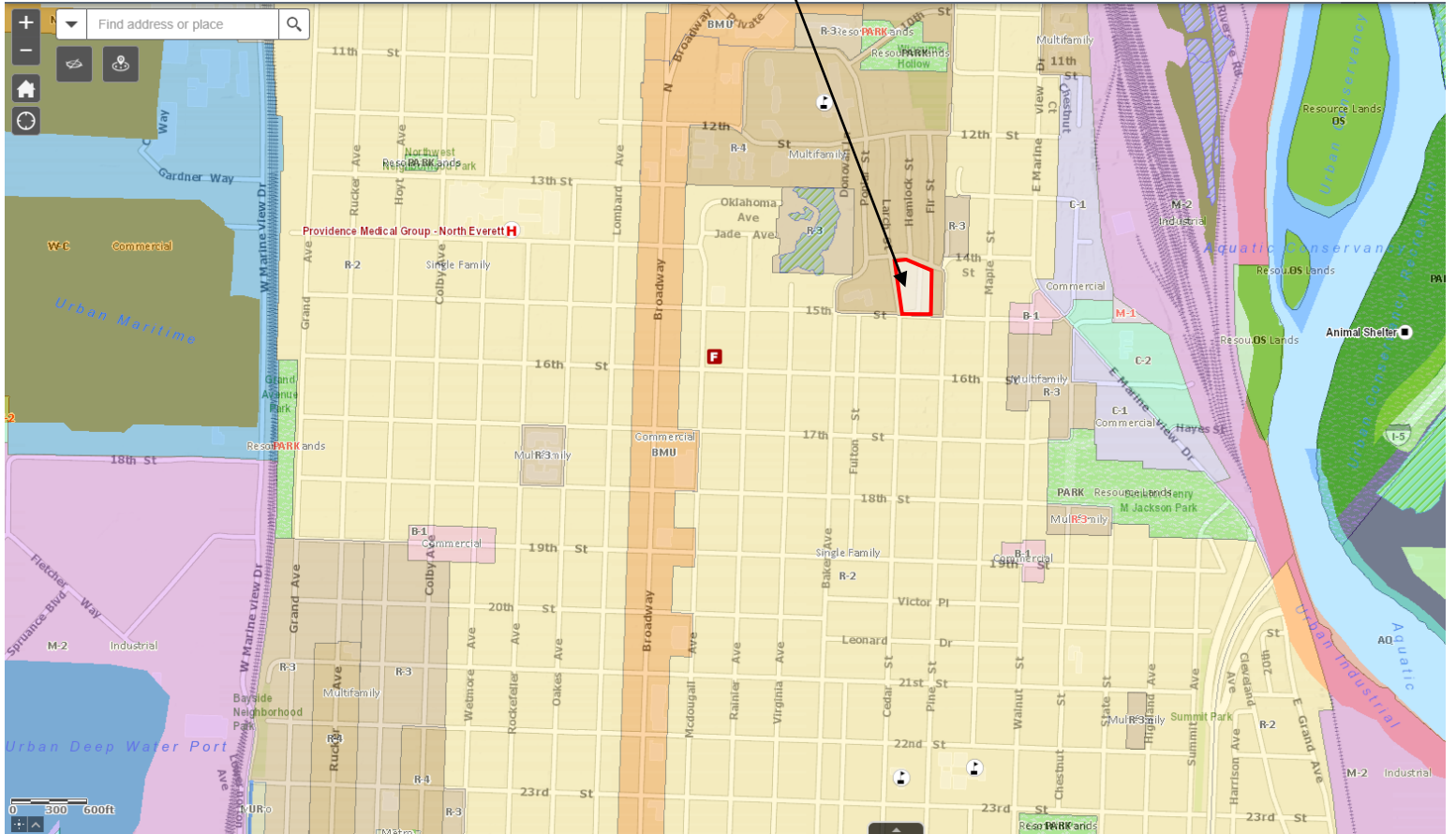

Below is a map from Snohomish County indicating that the project is within the urban growth area boundary.

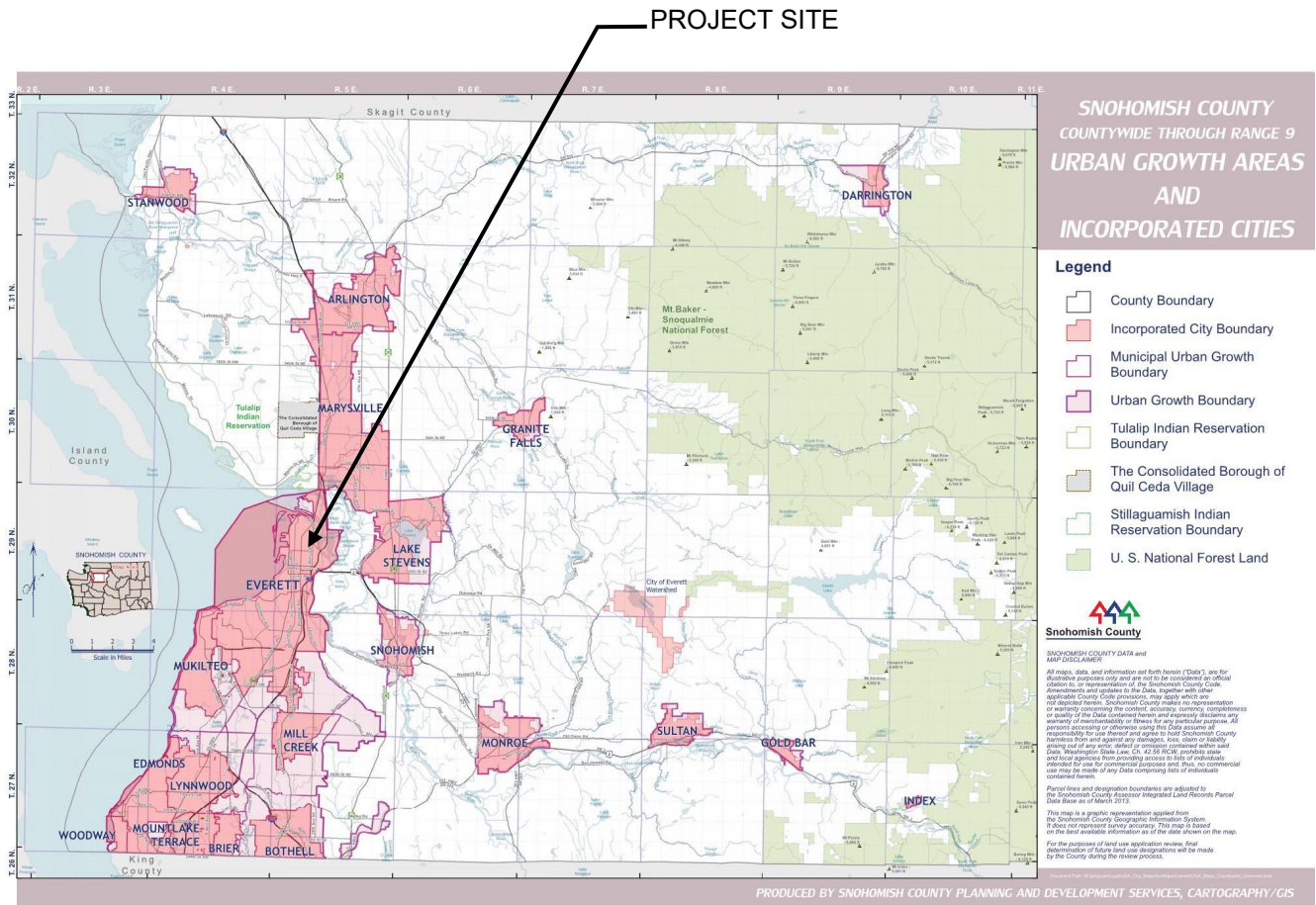

As shown in the aerial photo below, the project site is surrounded on all sides by existing development.



D

C

B

A

PLT DATE/TIME: 4/20/20 11:15:59 PM

PROJECT DIRECTORY

OWNER:
 EVERETT HOUSING AUTHORITY
 3107 COLBY AVENUE
 EVERETT, WA 98201
 PH: (425)-258-9222
 STEVE YAGO
 E: STEVEZ@EVHA.ORG

STRUCTURAL ENGINEER:
 MICHAEL NOUVENS STRUCTURAL CONSULTANTS
 P.O. BOX 921
 EDMONDS, WA 98020
 PH: (206)-546-9446
 MICHAEL NOUVENS
 MICHAEL@NOUVENS-STRUCTURAL.COM

ARCHITECT:
 GGLO DESIGN
 1301 FIRST AVENUE, SUITE 301
 SEATTLE, WA 98101
 PH: (206)-467-5828
 JON HALL
 JHALL@GGLO.COM

LANDSCAPE ARCHITECT:
 GGLO DESIGN
 1301 FIRST AVENUE, SUITE 301
 SEATTLE, WA 98101
 PH: (206)-467-5828
 MARIEKE LACASSE
 MLACASSE@GGLO.COM

CIVIL ENGINEER:
 KPFF CONSULTING ENGINEERS
 1601 5TH AVENUE, SUITE 1600
 SEATTLE, WA 98101
 PH: (206) 926-0519
 ALBERTO CISNEROS
 ALBERTO.CISNEROS@KPFF.COM

MECHANICAL/PLUMBING ENGINEER:
 GLUMAC
 1601 5TH AVENUE, SUITE 2210
 SEATTLE, WA 98101
 PH: (206)-262-1010
 SCOTT VOLLMOELLER
 SVOLLMOELLER@GLUMAC.COM

GEOTECHNICAL ENGINEER:
 GEODENGINEERS
 17425 NE UNION HILL ROAD, SUITE 250
 REDMOND, WASHINGTON 98052
 PH: (425)-861-6000
 ROBERT C. METCALFE

SURVEYOR:
 PACE ENGINEERS
 11255 KIRKLAND WAY, SUITE 300
 KIRKLAND, WA 98033
 PH: (425) 827-2014

INTERIOR DESIGNER:
 GGLO DESIGN
 1301 FIRST AVENUE, SUITE 301
 SEATTLE, WA 98101
 PH: (206)-467-5828
 GEORGE VALDEZ
 GVALDEZ@GGLO.COM

PROJECT ADDRESS BUILDING A: 2800 14TH STREET
 BUILDING B: 2825 15TH STREET
 BUILDING C: 2875 15TH STREET
 BUILDING D: 2850 14TH STREET
 EVERETT, WA 98201

RELATED PERMITS

LEGAL DESCRIPTION PARCEL 003862-001-000-00
 BLOCKS 1, 5, 7 AND 8, BAKER HEIGHTS, ACCORDING TO THE PLAT THEREOF
 RECORDED IN VOLUME 14 OF PLATS, PAGE 111, RECORDS OF
 SNOHOMISH COUNTY, WASHINGTON, TOGETHER WITH ANY PORTION OF
 VACATED PINE STREET THAT WOULD ATTACH BY LAW PER ORDINANCE
 1080-84 RECORDED UNDER AUDITOR'S FILE NO. 8506210070 AND ORDINANCE
 1034-84 RECORDED UNDER AUDITOR'S FILE NO. 861013077 RECORDS
 OF SNOHOMISH COUNTY, WASHINGTON.

SITUATE IN THE COUNTY OF SNOHOMISH, STATE OF WASHINGTON.

PARCEL 003862-006-000-03:
 LOT 3 OF CITY OF EVERETT BINDING SITE PLAN NO. P.F.N. BSP 14-001
 RECORDED UNDER AUDITOR'S FILE NO. 201404155001, BEING A PORTION OF
 BLOCK 6, BAKER HEIGHTS, ACCORDING TO THE PLAT THEREOF RECORDED IN
 VOLUME 14 OF PLATS, PAGE 111, RECORDS OF SNOHOMISH
 COUNTY, WASHINGTON.
 SITUATE IN THE COUNTY OF SNOHOMISH, STATE OF WASHINGTON.

EXISTING STRUCTURES CONCRETE BLOCK HOUSES DATING TO POST-WW11 ERA WITH SITE
 INFRASTRUCTURE AND UTILITIES.

PROPOSED USES REDEVELOPMENT AND NEW CONSTRUCTION PROJECT CONSISTING OF TWO
 SITES. THE FIRST IS A RELOCATION OF A COMMUNITY GARDEN AND THE
 SECOND IS A NEW HOUSING DEVELOPMENT CONSISTING OF FOUR
 BUILDINGS ON **3.19 ACRES** OF THE EXISTING SITE WITH APPROXIMATELY **105**
NEW UNITS.
 BUILDING A: 41 UNITS
 BUILDING B, C, D: 64 UNITS

TAX PARCEL NUMBER 003862-001-000-00
 003862-006-000-03

GENERAL NOTES

- IT IS THE INTENT OF THE CONTRACT DOCUMENTS THAT ALL WORK COMPLY WITH THE INTERNATIONAL BUILDING CODE, WASHINGTON STATE BUILDING CODE, THE WASHINGTON STATE ENERGY CODE, AND OTHER APPLICABLE CODES, RULES, AND REGULATIONS OF JURISDICTIONS HAVING AUTHORITY.
- PRIOR TO COMMENCEMENT OF ANY PORTION OF THE WORK, THE CONTRACTOR SHALL NOTIFY THE ARCHITECT OF ANY DISCREPANCIES NOTED AMONG OR BETWEEN THE CONTRACT DOCUMENTS, OWNER-PROVIDED INFORMATION, SITE CONDITIONS, MANUFACTURER RECOMMENDATIONS, OR CODES, REGULATIONS, OR RULES OF JURISDICTIONS HAVING AUTHORITY.
- THE CONTRACTOR SHALL SECURE AND PAY FOR ALL GOVERNMENTAL PERMITS, FEES LICENSES, AND INSPECTIONS NECESSARY FOR PROPER EXECUTION AND COMPLETION OF THE WORK, EXCEPT FOR THE CODES COMMERCIAL/MULTI-FAMILY BUILDING PERMIT.
- THE CONTRACT DOCUMENTS ARE COMPLEMENTARY AND WHAT IS REQUIRED BY ONE SHALL BE BINDING AS IF REQUIRED BY ALL.
- REPETITIVE FEATURES NOT INDICATED IN THE DRAWINGS EVERYWHERE THAT THEY OCCUR SHALL BE PROVIDED AS IF DRAWN IN FULL.
- ALL DIMENSIONS ARE TO FACE OF FRAMING OR FACE OF CONCRETE, UNLESS OTHERWISE NOTED. CONTACT ARCHITECT FOR CLARIFICATIONS.
- DO NOT SCALE THE DRAWINGS.

VICINITY MAP

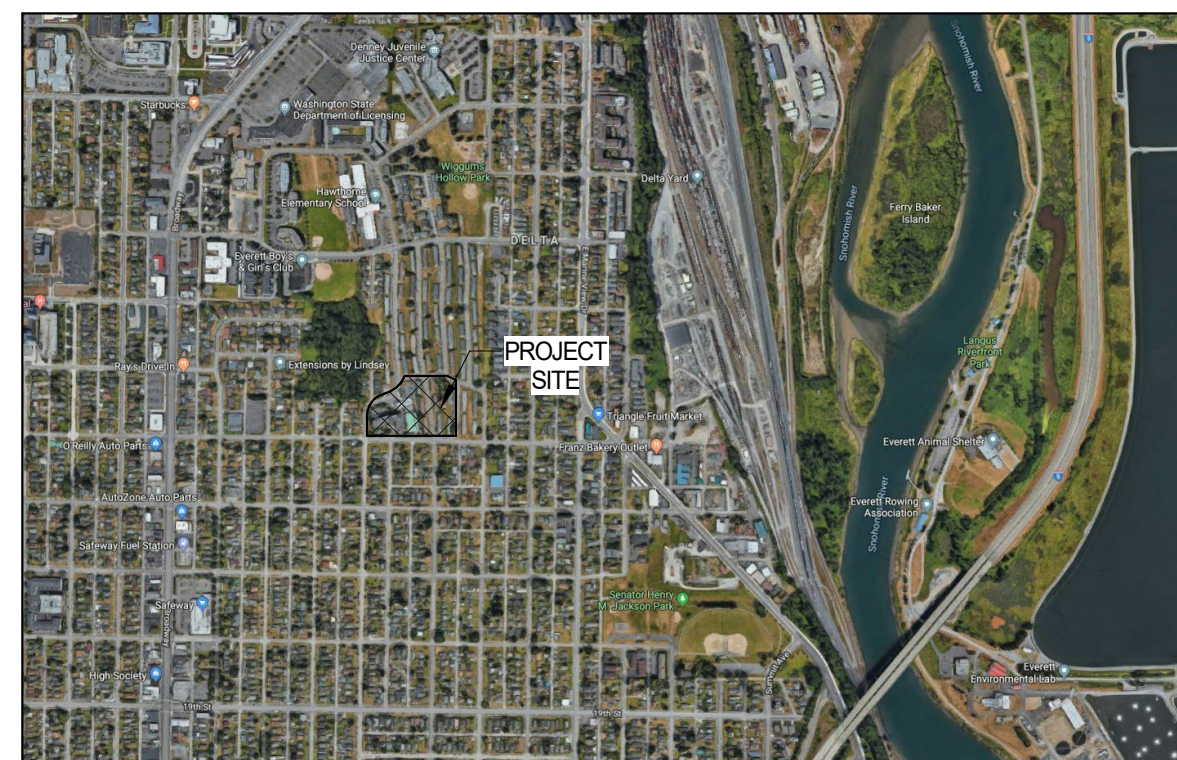

DESIGN DEVELOPMENT

APPROVAL STAMPS



1301 First Avenue, Suite 301
 Seattle, WA 98101
<http://www.gglo.com>

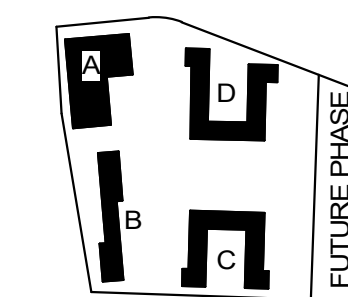

PROJECT:

EHA BAKER HEIGHTS



PROJECT ADDRESS:

BUILDING A: 2800 14TH STREET
BUILDING B: 2825 15TH STREET
BUILDING C: 2875 15TH STREET
BUILDING D: 2850 14TH STREET
EVERETT, WA 98201

OWNER:

EVERETT HOUSING AUTHORITY

MARK	DATE	DESCRIPTION
------	------	-------------

REVISIONS

A	04/10/2020	DESIGN DEVELOPMENT
A	01/07/2020	SCHEMATIC DESIGN

MARK	DATE	DESCRIPTION
------	------	-------------

ISSUE INFORMATION

PROJECT NO.: **2017033.00**
 GGLO PRINCIPAL IN CHARGE: **JON HALL**
 GGLO PROJECT MANAGER: **SCOTT SCHREFFLER**
 OWNER APPROVAL: _____

SHEET TITLE

PROJECT DIRECTORY

SHEET NO.

G-003

2.4 Maximizing Density

Density of Census Block Group by address as calculated by: <http://apps.cnt.org/residential-density/#>

BUILDING A – 2800 14th Street, Everett, WA 98201 = **9.99**

BUILDING B - 2825 15th Street, Everett, WA 98201 = **9.99**

BUILDING C - 2875 15th Street, Everett, WA 98201 = **9.99**

BUILDING D - 2850 14th Street, Everett, WA 98201 = **5.83**

Net Density = **35.8**

Net Density multiplied by 2 = $35.8 \times 2 =$ **71.6**

Statement of Correctness:

These numbers are based on surveyed site area and the number of dwelling units as designed and submitted to the City of Everett for permit. See the attached drawing sheets (G-002) from the permit set with these numbers highlighted.

The project has 5 combined transit stops within a 1000' radius, and several within the required ½ mile radius.

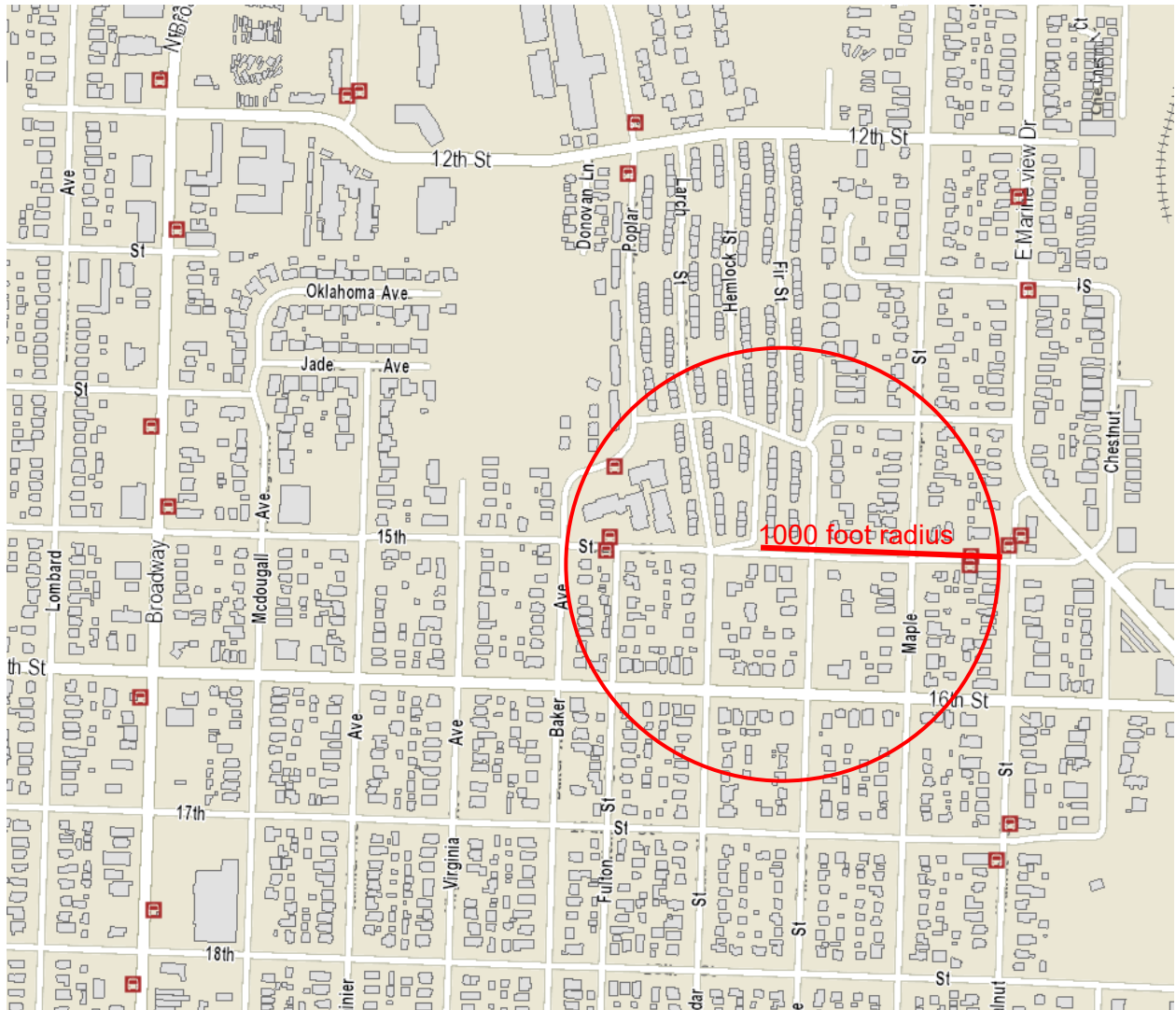

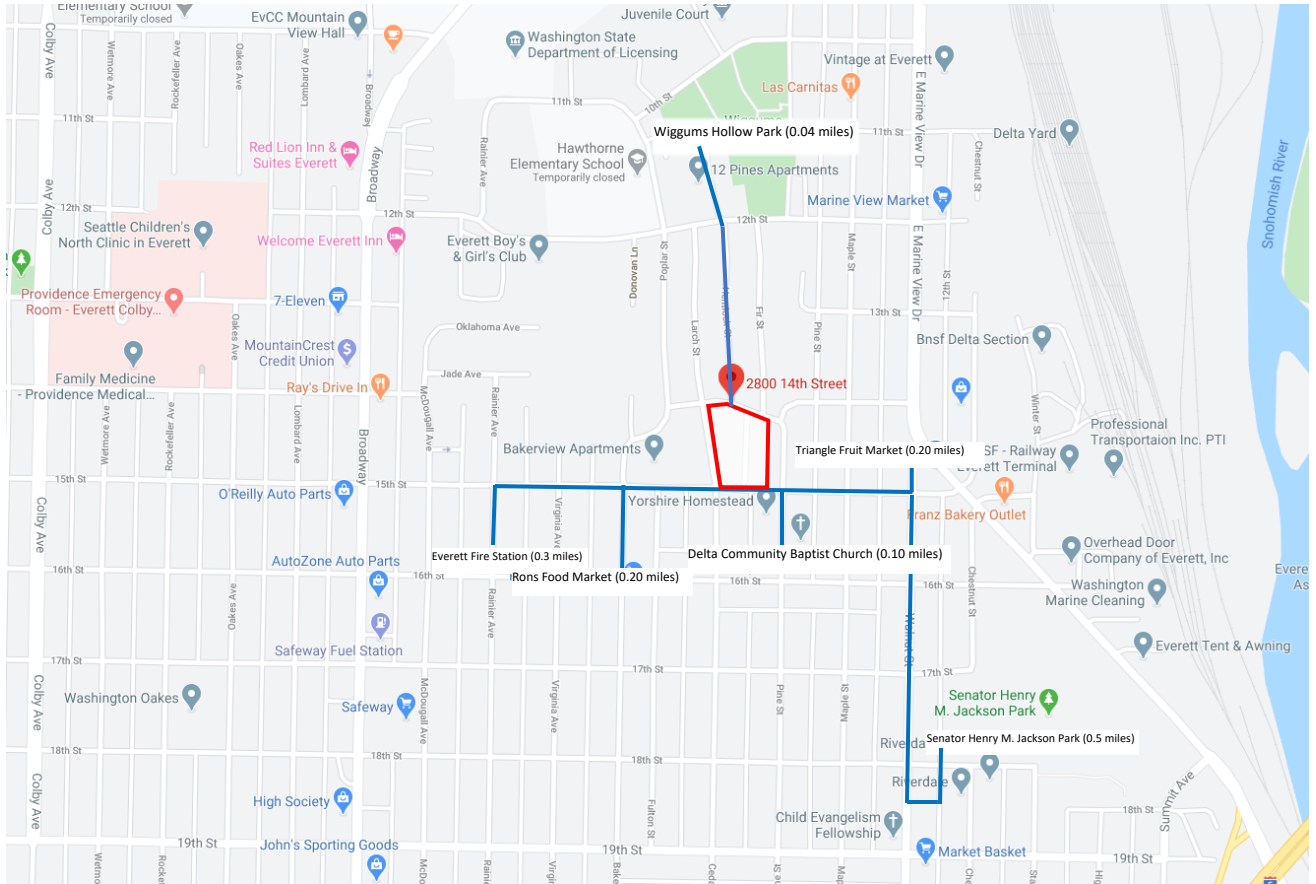

EHA – Baker Heights Redevelopment
ESDS 2.6 – Preservation and Access to Open Space
GGLO No. 2017033

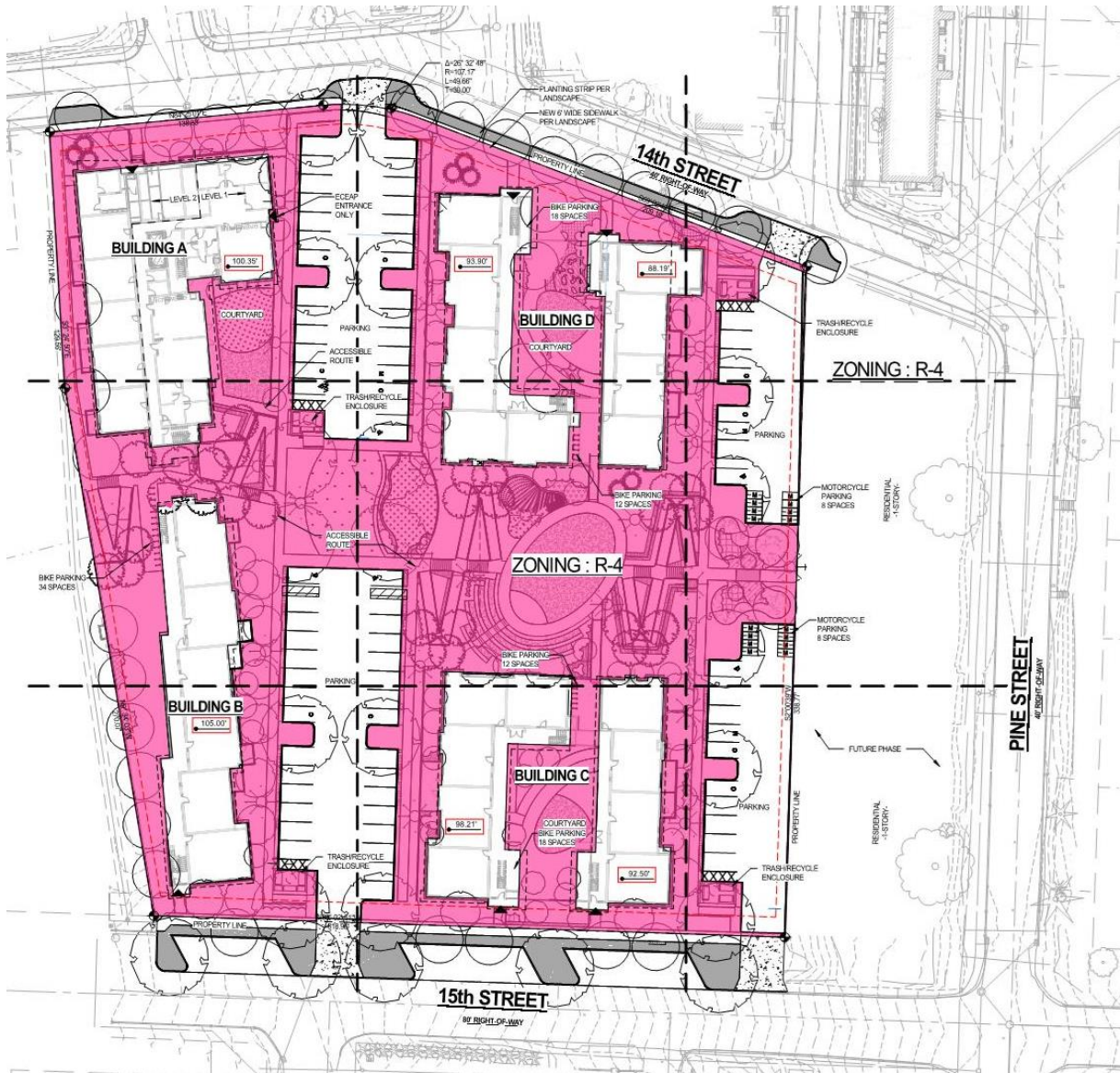

Site Area: 138,311 SF

Open Space: 72,572 SF

52% Open Space

EHA – Baker Heights Redevelopment
ESDS 2.7a – Walkable Neighborhoods – Sidewalks and Pathways
GGLO No. 2017033

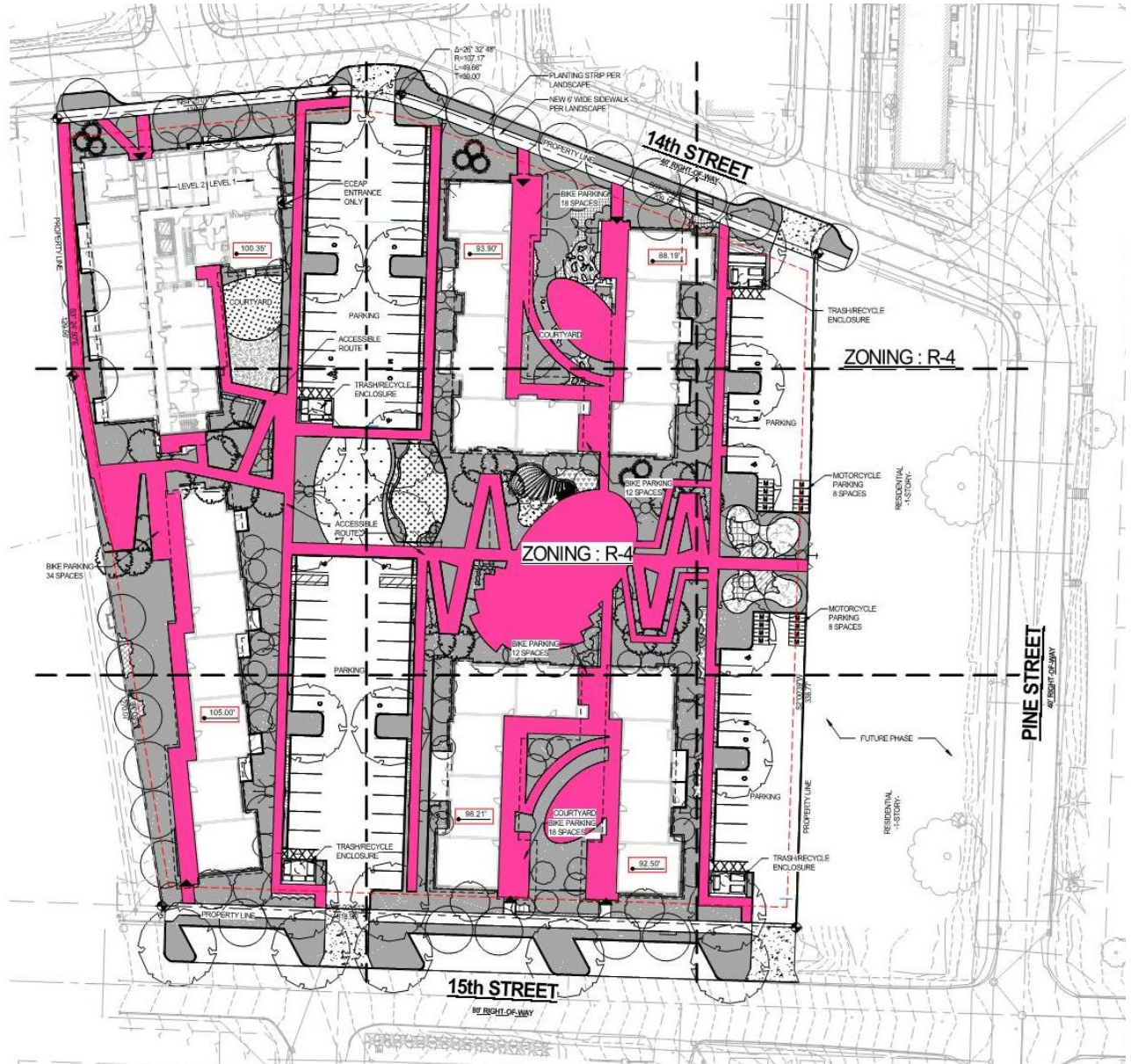

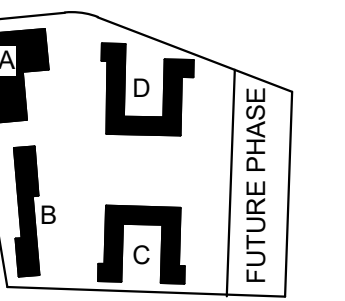

PROJECT:
EHA BAKER HEIGHTS



PROJECT ADDRESS:
BUILDING A: 2800 14TH STREET
BUILDING B: 2825 15TH STREET
BUILDING C: 2875 15TH STREET
BUILDING D: 2850 14TH STREET
EVERETT, WA 98201

OWNER:
EVERETT HOUSING AUTHORITY
3107 COLBY AVENUE
EVERETT, WA 98201

MARK DATE DESCRIPTION
REVISIONS

B 04/10/2020 DESIGN DEVELOPMENT
A 01/07/2020 SCHEMATIC DESIGN

MARK DATE DESCRIPTION
ISSUE INFORMATION

PROJECT NO.: **2017033.00**
GGLO PRINCIPAL IN CHARGE: **JON HALL**
GGLO PROJECT MANAGER: **SCOTT SCHREFFLER**
OWNER APPROVAL:

SHEET TITLE
LANDSCAPE KEY PLAN

SHEET NO.
L-100

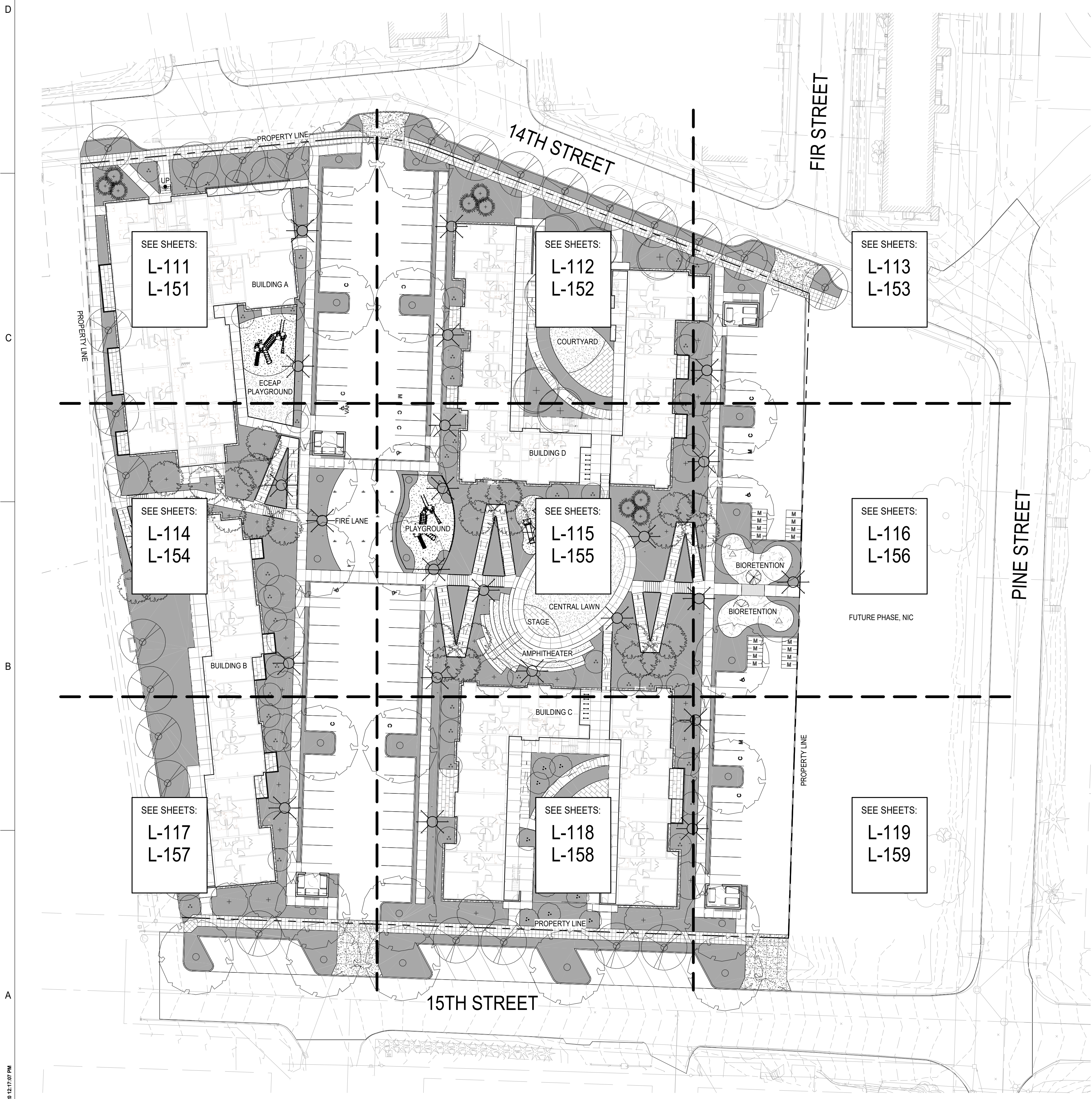

SEE SHEETS:
L-111
L-151

SEE SHEETS:
L-112
L-152

SEE SHEETS:
L-113
L-153

SEE SHEETS:
L-114
L-154

SEE SHEETS:
L-115
L-155

SEE SHEETS:
L-116
L-156

SEE SHEETS:
L-117
L-157

SEE SHEETS:
L-118
L-158

SEE SHEETS:
L-119
L-159

A1 LANDSCAPE KEY PLAN
1" = 30'-0"

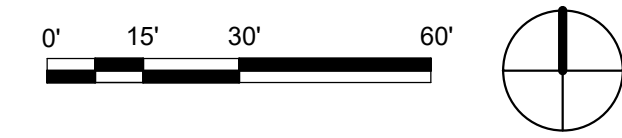

DESIGN DEVELOPMENT

1301 First Avenue, Suite 301
Seattle, WA 98101

<http://www.gglo.com>

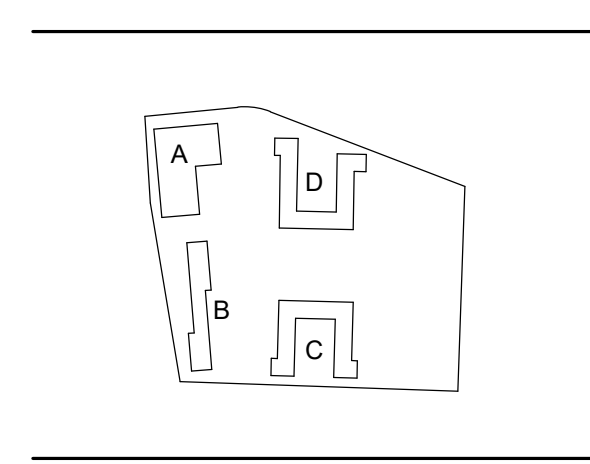

1601 Fifth Ave., Suite 2210
Seattle, WA 98101
www.glumac.com
T. 206.262.1010
Project Manager: DeNayne Glenn
Job No.: 201900169

PROJECT:
EHA BAKER HEIGHTS
EVERETT HOUSING AUTHORITY

PROJECT ADDRESS:
EVERETT, WA 98201

OWNER:
EVERETT HOUSING AUTHORITY
3107 COLBY AVE
EVERETT, WA 98201

MARK	DATE	DESCRIPTION
REVISIONS		

MARK	DATE	DESCRIPTION
B	04/08/2020	100% DESIGN DEVELOPMENT
A	01/02/2020	SCHEMATIC DESIGN
ISSUE INFORMATION		

PROJECT NO.: **2017033**
PRINCIPAL IN CHARGE: **Scott Vollmoeller**
PROJECT MANAGER: **DeNayne Glenn**
OWNER APPROVAL: _____

SHEET TITLE
PLUMBING LEGEND AND ABBREVIATIONS

SHEET NO.
P-000

PLUMBING BASIS OF DESIGN

1.1 PLUMBING BASIS OF DESIGN
A. THIS BUILDING IS A NEW FOUR (4) LEVEL MULTI-FAMILY BUILDING. THE BUILDING CONSIST RESIDENTIAL UNITS AND RESIDENTIAL COMMON SPACES.
B. THE DESIGN INCLUDES THE FOLLOWING NOTABLE FEATURES, BUT IS NOT LIMITED TO THIS SCOPE. CONTRACTOR IS RESPONSIBLE FOR REVIEWING ALL CONTRACT DOCUMENTS AND COORDINATING WITH ALL DISCIPLINES.
1. DOMESTIC HOT WATER DISTRIBUTION: RECIRCULATION PUMPS ARE USED TO MAINTAIN A MINIMUM WATER TEMPERATURE OF 110 DEGREES F IN THE MAIN PIPING LOOP. PIPING WILL BE LOCATED TO EXPEDITE HOT WATER SERVICE TO ANY FIXTURE. DOMESTIC HOT WATER IS CONTROLLED BY RETURN WATER TEMPERATURE.
C. CODES AND STANDARDS
1. AMERICANS WITH DISABILITIES ACT (ADA)
2. NFPA 99, HEALTH CARE FACILITIES CODE, 2012 EDITION
3. WASHINGTON BUILDING CODES ENFORCED BY THE AUTHORITY HAVING JURISDICTION (AHJ):
A) 2015 INTERNATIONAL BUILDING CODE (IBC) WITH STATE AND LOCAL AMEND.
B) 2015 UNIFORM PLUMBING CODE (UPC) WITH STATE AND LOCAL AMEND.
C) 2015 INTERNATIONAL FUEL GAS CODE (IFGC) NFPA 54, WAC 51-52
D) 2015 WASHINGTON STATE ENERGY CODE (WAC 51-11, WSEC)
D. OUTDOOR DESIGN CONDITIONS (FOR INSULATION AND GAS FIRING CRITERIA):
1. SUMMER: 84°F (ASHRAE 0.5%, EVERETT, WA)
2. WINTER: 24°F (ASHRAE 0.6%, EVERETT, WA)
E. WATER SUPPLY:
1. REFER TO WATER AND WASTE SERVICE CALCULATIONS
F. DOMESTIC HOT WATER:
1. DOMESTIC HOT WATER SUPPLY TEMPERATURE TO ALL PUBLIC AREAS: 120°F
2. DOMESTIC HOT WATER SUPPLY TEMPERATURE TO ALL RESIDENTIAL UNITS: 120°F
3. DOMESTIC HOT WATER SUPPLY TEMPERATURE TO ALL COMMERCIAL AND NON-PUBLIC AREAS: 120°F
4. DOMESTIC HOT WATER RECIRCULATION TEMPERATURE: 110°F. ABOVE THIS TEMPERATURE THE RECIRCULATING PUMP WILL BE OFF.
5. DOMESTIC INCOMING COLD WATER TEMPERATURE: 50°F (USED FOR WATER HEATER SIZING)
6. DOMESTIC HOT WATER HEATER SETPOINT TEMPERATURE: 140°F
7. DOMESTIC SHOWER DEMAND PERIOD: 2 HOURS BETWEEN 6 AM AND 8 AM.
8. DEMAND PERIOD FOR PEAK SHOWER WATER USAGE: 8 MINUTES PER SHOWER AND 20 MINUTES PER HOUR PER SHOWER COMPARTMENT.
G. SANITARY SEWER:
1. BUILDING SEWER SIZES, ONE (1) 6 INCHES AT 1/8"/FT SLOPE
2. TOTAL CAPACITY 576 DRAINAGE FIXTURE UNITS
3. CONNECTED LOAD 353 DRAINAGE FIXTURE UNITS
4. CALCULATIONS DONE PER APPENDIX C OF THE 2015 UNIFORM PLUMBING CODE REFER TO WATER AND WASTE SERVICE CALCULATIONS
H. STORM DRAIN:
1. RAINFALL INTENSITY 1 INCHES/HOUR (PER LOCAL ORDINANCE) FOR SPLIT SYSTEMS
2. RAINFALL INTENSITY 2 INCHES/HOUR (PER LOCAL ORDINANCE) FOR COMBINED SYSTEMS
3. REFER TO PLANS FOR AREA SERVED BY ROOF DRAINS
I. NATURAL GAS SERVICE:
1. GAS PROVIDER: PUGET SOUND ENERGY (PSE)
2. DELIVERY OF LOW PRESSURE GAS: 6" W.C.
3. REFER TO PLANS FOR NATURAL GAS SIZING CALCULATIONS
J. SEISMIC:
1. ANCHORAGE AND RESTRAINTS MUST BE COORDINATED WITH STRUCTURAL ENGINEER AND AUTHORITY HAVING JURISDICTION.

WSEC 2015 COMPLIANCE

1. PROVIDE BALANCING DEVICES IN ALL BRANCH DUCTS AND PIPE RUNS TO TERMINAL DEVICES AS INDICATED ON THE CONTRACT DOCUMENTS.
2. ALL PIPING SHALL BE INSULATED AS REQUIRED BY SECTION C403.3.2.9 OF THE WSEC AND AS DESCRIBED IN SPECIFICATIONS.
TABLE:
SYSTEM TEMP. (F) | INSULATION CONDUCTIVITY | < 1.0" | 1.0" - 1.5" | 1.5" - 4.0" | 4.0" - 8.0" | > 8.0"
PIPE DIAMETER INSULATION THICKNESS (IN.) | 1.0 | 1.0 | 1.5 | 1.5 | 1.5 | 1.5 | 1.5 | 1.0 | 1.0 | 1.0 | 1.5 | 1.5 | 1.0 | 1.0 | 1.5 | 1.5
3. WATER TEMPERATURES SHALL BE AUTOMATICALLY RESET AS REQUIRED IN SECTION C403.4.2.4 OF THE WSEC OR AS DESCRIBED IN THE TEMPERATURE CONTROL SEQUENCES.
4. RECORD DRAWINGS SHALL BE PROVIDED TO THE OWNER WITHIN 90 DAYS AFTER THE DATE OF SYSTEM ACCEPTANCE AS REQUIRED BY SECTION C408.3.2 OF THE WSEC. THE DRAWINGS SHALL INDICATE THE LOCATION AND PERFORMANCE DATA OF EQUIPMENT, GENERAL CONFIGURATION OF DUCTWORK AND PIPING DISTRIBUTION SYSTEMS, INCLUDING FLOW RATES AS A MINIMUM.
5. OPERATION AND MAINTENANCE MANUALS SHALL BE PROVIDED TO THE OWNER AS REQUIRED BY SECTION C103.6.2 OF THE WSEC. AS A MINIMUM, THE MANUALS SHALL INCLUDE:
SUBMITTAL DATA
A. OPERATION AND MAINTENANCE DATA FOR EQUIPMENT.
B. NAMES AND ADDRESSES OF SERVICE AGENCIES.
C. HVAC CONTROLS SYSTEM MAINTENANCE AND CALIBRATION INFORMATION.
D. NARRATIVE OF HOW SYSTEM IS INTENDED TO OPERATE
6. SYSTEMS SHALL BE BALANCED AS REQUIRED BY SECTION C408.2.2 OF THE WSEC.
7. COMMISSIONING SHALL BE PROVIDED AND REPORT OF COMMISSIONING BE SUBMITTED TO THE OWNER AS REQUIRED BY SECTION C408 OF THE WSEC, AND AS CALLED OUT IN SPECIFICATIONS.

ABBREVIATIONS

ABV ABOVE
AD ACCESS DOOR
ADA AMERICANS WITH DISABILITIES ACT
AFF ABOVE FINISHED FLOOR
AFG ABOVE FINISHED GRADE
AP ACCESS PANEL
ARCH ARCHITECT
ASR AUTO FIRE SPRINKLER RISER
BAS BUILDING AUTOMATION SYSTEM
BFV BUTTERFLY VALVE
BHP BRAKE HORSEPOWER
BTU BRITISH THERMAL UNIT
BV BALL VALVE
BWV BACKWATER VALVE
CA COMPRESSED AIR
CD CONDENSATE DRAIN
CR STEAM CONDENSATE RETURN
CFF CAP FOR FUTURE
CFH CUBIC FEET PER HOUR
CFM CUBIC FEET PER MINUTE
CFS CUBIC FEET PER SECOND
CI CAST IRON
CLG CEILING
CO CLEANOUT
CONC CONCRETE
CONC CHECK VALVE
CW DOMESTIC COLD WATER
CWU COLD WATER FIXTURE UNIT
DN DOWN
DCVA DOUBLE CHECK VALVE ASSEMBLY
DDCVA DOUBLE DETECTOR CHECK VALVE ASSEMBLY
DFU DRAINAGE FIXTURE UNIT
DIA DIAMETER
DSN DOWNSPOUT NOZZLE
DWG DRAWING
DWV DRAINAGE WASTE AND VENT
E EXISTING
ELEC ELECTRICAL
FA FLOW ALARM
FC FLEXIBLE CONNECTION
FCO FLOOR CLEANOUT
FDV FIRE DEPARTMENT VALVE
FDVC FIRE DEPARTMENT VALVE CABINET
FFA/FFB FROM FLOOR ABOVE/BELOW
FFE FINISHED FLOOR ELEVATION
FH FIRE HYDRANT
FHV FIRE HOSE VALVE
FIN FINISHED
FO FUEL OIL
FPS FEET PER SECOND
FT FEET
FT FLUSH TANK
FU FIXTURE UNIT
FV FLUSH VALVE
G GAS
GAL GALLONS
GC GAS COCK
GPH GALLONS PER HOUR
GPM GALLONS PER MINUTE
GV GATE VALVE
HD HUB DRAIN
HP HORSEPOWER
HW DOMESTIC HOT WATER
HWC DOMESTIC HOT WATER RECIRCULATION
HWFU HOT WATER FIXTURE UNIT
IAPMO INTERNATIONAL ASSOCIATION OF PLUMBING AND MECHANICAL OFFICIALS
ICBO INTERNATIONAL CONFERENCE OF BUILDING OFFICIALS
IE INVERT ELEVATION
IRR IRRIGATION
LAV LAVATORY
LBS POUNDS (UNIT OF FORCE)
MAX MAXIMUM
MBH THOUSANDS BTU/HR
MECH MECHANICAL
MFR MANUFACTURER
MIN MINIMUM
MH MANHOLE
NC NORMALLY CLOSED
NFPA NATIONAL FIRE PROTECTION ASSOCIATION
NO NORMALLY OPEN OR NUMBER
NIC NOT IN CONTRACT
OFCI OWNER FURNISHED CONTRACTOR INSTALLED
OW OIL WASTE
POC POINT OF CONNECTION
POD POINT OF DISCONNECTION
PRV PRESSURE REDUCING VALVE
PS PRESSURE SWITCH
PSI POUNDS PER SQUARE INCH
R/I&C ROUGH IN AND CONNECT
R RELOCATE, RISE, RISER
RP REDUCED-PRESSURE PRINCIPLE BACKFLOW PREVENTION ASSEMBLY
RPM REVOLUTIONS PER MINUTE
SD STORM DRAIN
SF SQUARE FEET
SHWR SOLAR HOT WATER RETURN
SHWS SOLAR HOT WATER SUPPLY
SOV SHUT-OFF VALVE
SPR SPRINKLER
SS SANITARY SEWER
TFAT/TFB TO FLOOR ABOVE/BELOW
TP TRAP PRIMER
TS TAMPER SWITCH
TT TEST TEE
TYP TYPICAL
U URINAL
VB VACUUM BREAKER
V VENT
VTR VENT THROUGH ROOF
W WASTE
WC WATER CLOSET
WHA WATER HAMMER ARRESTOR
WCO WALL CLEANOUT
W WITH
YB YARD BOX

SYMBOL	DESCRIPTION
[Symbol]	TRAP PRIMER
[Symbol]	BALL VALVE
[Symbol]	BUTTERFLY VALVE
[Symbol]	GATE VALVE
[Symbol]	BALANCING VALVE
[Symbol]	SHUT OFF VALVE IN CONCRETE YARD BOX
[Symbol]	ANGLE GATE VALVE
[Symbol]	SOLENOID VALVE
[Symbol]	CHECK VALVE
[Symbol]	PRESSURE REDUCING VALVE
[Symbol]	MIXING VALVE
[Symbol]	PLUG VALVE / GAS COCK
[Symbol]	RELIEF VALVE
[Symbol]	VACUUM RELIEF VALVE
[Symbol]	PRESSURE & TEMPERATURE RELIEF VALVE
[Symbol]	AUTOMATIC AIR VENT
[Symbol]	BACKWATER VALVE
[Symbol]	REDUCED - PRESSURE PRINCIPLE BACKFLOW PREVENTION ASSEMBLY (RP)
[Symbol]	UNION
[Symbol]	STRAINER
[Symbol]	STRAINER WITH BLOW OFF HOSE BIBB
[Symbol]	PIPE ANCHOR
[Symbol]	PIPE ALIGNMENT GUIDE
[Symbol]	EXPANSION JOINT
[Symbol]	FLEXIBLE CONNECTOR
[Symbol]	CAP OR PLUG
[Symbol]	BLIND FLANGE
[Symbol]	CONCENTRIC REDUCER
[Symbol]	AQUASTAT
[Symbol]	WATER HAMMER ARRESTOR
[Symbol]	PRESSURE GAUGE WITH COCK
[Symbol]	THERMOMETER
[Symbol]	CLEANOUT / WALL CLEANOUT
[Symbol]	FLOOR CLEANOUT / CLEANOUT TO GRADE
[Symbol]	YARD CLEANOUT / CLEANOUT TO GRADE
[Symbol]	TEST TEE
[Symbol]	WALL HYDRANT
[Symbol]	HOSE BIBB
[Symbol]	YARD HYDRANT
[Symbol]	THRUST BLOCK
[Symbol]	FLOOR DRAIN
[Symbol]	FLOOR SINK W/ GRATE AS SHOWN
[Symbol]	OIL WASTE
[Symbol]	HUB DRAIN
[Symbol]	ROOF RECEPTOR
[Symbol]	STORM DRAIN
[Symbol]	OVERFLOW DRAIN
[Symbol]	DECK DRAIN, PLANTER DRAIN
[Symbol]	DOWN SPOUT NOZZLE
[Symbol]	SUB-METER

NOTE: NOT ALL SYMBOLS OR ABBREVIATIONS ARE APPLICABLE TO THIS PROJECT. REFER TO DETAILS AND NOTES FOR MOUNTING HEIGHTS.

SYMBOL	DESCRIPTION
[Symbol]	DIRECTION OF SLOPE
[Symbol]	DIRECTION OF FLOW
[Symbol]	PIPE UP OR UP & DN
[Symbol]	PIPE DOWN
[Symbol]	PIPE DROP
[Symbol]	TOP CONNECTION - BRANCH LINE
[Symbol]	BOTTOM CONNECTION - BRANCH LINE
[Symbol]	COLD WATER
[Symbol]	HOT WATER
[Symbol]	HOT WATER RECIRCULATION
[Symbol]	HOT WATER (140°F)
[Symbol]	VENT
[Symbol]	PIPING BELOW GRADE OR FLOOR
[Symbol]	PIPING ABOVE GRADE OR FLOOR
[Symbol]	SANITARY SEWER, WASTE OR SOIL
[Symbol]	STORM DRAIN, RAINWATER DRAIN PIPING
[Symbol]	OVERFLOW STORM DRAIN PIPING
[Symbol]	PUMPED DISCHARGE
[Symbol]	DRAIN LINE
[Symbol]	INDIRECT WASTE
[Symbol]	GREASE WASTE
[Symbol]	NATURAL GAS (7"W.C.)
[Symbol]	MEDIUM PRESSURE GAS (2 PSIG TO 5 PSIG)
[Symbol]	LOW PRESSURE GAS
[Symbol]	COMPRESSED AIR
[Symbol]	EXISTING PIPE
[Symbol]	TEMPERED WATER
[Symbol]	TEMPERED WATER RETURN
[Symbol]	PIPE SIZE (DIAMETER IN INCHES)
[Symbol]	EXISTING WORK TO REMAIN
[Symbol]	EXISTING WORK TO BE REMOVED
[Symbol]	FUTURE WORK
[Symbol]	EXISTING RELOCATED
[Symbol]	CENTER LINE
[Symbol]	POINT OF CONNECTION OR POINT OF DISCONNECTION
[Symbol]	SANITARY & VENT SEWER STACK
[Symbol]	COLD & HOT WATER RISER
[Symbol]	HOT WATER RECIRC. RISER
[Symbol]	GAS RISER
[Symbol]	STORM DRAIN RISER
[Symbol]	OVERFLOW DRAIN RISER
[Symbol]	COMPRESSED AIR RISER
[Symbol]	PLUMBING EQUIPMENT
[Symbol]	MISCELLANEOUS EQUIPMENT
[Symbol]	KEYED NOTE
[Symbol]	DETAIL NO. SHEET NO.
[Symbol]	POUNDS OR NUMBER

FIRE PROTECTION

SYMBOL	DESCRIPTION
[Symbol]	FIRE MAIN
[Symbol]	AUTOMATIC WET SPRINKLER
[Symbol]	COMBINATION STAND PIPE
[Symbol]	DRY STAND PIPE
[Symbol]	DOUBLE DETECTOR CHECK VALVE ASSEMBLY
[Symbol]	DOUBLE CHECK VALVE BACKFLOW PREVENTION ASSEMBLY (DC)
[Symbol]	OS & Y GATE VALVE (OUTSIDE SCREW & YOKE GATE VALVE)
[Symbol]	OS & Y GATE VALVE WITH TAMPER SWITCH
[Symbol]	FIRE DEPARTMENT CONNECTION
[Symbol]	AUTO FIRE SPRINKLER RISER
[Symbol]	FIRE DEPARTMENT VALVE
[Symbol]	FIRE DEPARTMENT VALVE CABINET
[Symbol]	FIRE SPRINKLER FLOOR CONTROL VALVE
[Symbol]	SIEMESE FIRE DEPT. CONN.
[Symbol]	ROOF MANIFOLD
[Symbol]	FIRE HOSE VALVE
[Symbol]	FIRE ALARM BELL
[Symbol]	PRESSURE SWITCH
[Symbol]	FLOW ALARM
[Symbol]	FLOW SWITCH
[Symbol]	AUTOMATIC WET SPRINKLER RISER
[Symbol]	AUTOMATIC SPRINKLER DRAIN
[Symbol]	WET STANDPIPE RISER

PLUMBING DRAWING LIST

P-000	PLUMBING LEGEND AND ABBREVIATIONS
P-001	PLUMBING SCHEDULES
P-100	PLUMBING SITE PLAN
PA-010	BUILDING A - UNDERGROUND PLAN - PLUMBING
PA-110	BUILDING A - LEVEL 1 - PLUMBING
PA-111	BUILDING A - LEVEL 2 - PLUMBING
PA-112	BUILDING A - LEVEL 3 - PLUMBING
PA-113	BUILDING A - LEVEL 4 - PLUMBING
PA-114	BUILDING A - ROOF - PLUMBING
PA-703	GAS RISER DIAGRAM
PA-701	DOMESTIC WATER RISER DIAGRAM
PA-702	SANITARY SEWER AND VENT RISER DIAGRAM
PB-010	BUILDING B - UNDERGROUND PLAN - PLUMBING
PB-110	BUILDING B - LEVEL 1 AND 2 - PLUMBING
PB-111	BUILDING B - LEVEL 3 AND ROOF - PLUMBING
PB-701	DOMESTIC WATER RISER DIAGRAM
PB-702	SANITARY AND VENT RISER DIAGRAM
PC-010	BUILDING C - UNDERGROUND PLAN - PLUMBING
PC-110	BUILDING C - LEVEL 1 - PLUMBING
PC-111	BUILDING C - LEVEL 2 - PLUMBING
PC-112	BUILDING C - LEVEL 3 - PLUMBING
PC-701	DOMESTIC WATER RISER DIAGRAM
PC-702	SANITARY AND VENT RISER DIAGRAM
PD-010	BUILDING D - UNDERGROUND PLAN - PLUMBING
PD-110	BUILDING D - LEVEL 1 - PLUMBING
PD-111	BUILDING D - LEVEL 2 - PLUMBING
PD-112	BUILDING D - LEVEL 3 - PLUMBING
PD-113	BUILDING D - ROOF - PLUMBING
PD-701	DOMESTIC WATER RISER DIAGRAM
PD-702	SANITARY AND VENT RISER DIAGRAM
P-901	PLUMBING DETAILS
P-902	PLUMBING DETAILS

DESIGN DEVELOPMENT

APPROVAL STAMPS

D

C

B

A

WATER AND WASTE SERVICE CALCULATIONS								
JOB NAME: EHA BAKER HEIGHTS BLDG A			DATE: 03/02/20		USER: JEE			
JOB NUMBER: 20US00169								
FIXTURE TYPE	NO.	WASTE		COLD WATER		HOT WATER		TOTAL WATER
		FU	TOTAL	FU	TOTAL	FU	TOTAL	
BATH TUB/SHOWER	41	2	82	3	123	3	123	164
KITCHEN SINK (DOMESTIC)	41	2	82	1.125	46.125	1.125	46.125	61.5
LAVATORY	44	1	44	0.75	33	0.75	33	44
FLOOR DRAIN	3	2	6	0	0	0	0	0
WATER CLOSET, TANK	41	3	123	2.5	102.5	0	0	102.5
WATER CLOSET, TANK, PUBLIC	4	4	16	2.5	10	0	0	10
MISCELLANEOUS FIXTURE	0	0	0	0	0	0	0	0
TOTAL FU			353.0		314.6		202.1	382.0

WATER AND WASTE SERVICE CALCULATIONS								
JOB NAME: EHA BAKER HEIGHTS BLDG B			DATE: 03/02/20		USER: JEE			
JOB NUMBER: 20US00169								
FIXTURE TYPE	NO.	WASTE		COLD WATER		HOT WATER		TOTAL WATER
		FU	TOTAL	FU	TOTAL	FU	TOTAL	
BATH TUB/SHOWER	21	2	42	3	63	3	63	84
CLOTHES WASHER	18	3	54	3	54	3	54	72
KITCHEN SINK (DOMESTIC)	18	2	36	1.125	20.25	1.125	20.25	27
LAVATORY	21	1	21	0.75	15.75	0.75	15.75	21
WATER CLOSET, TANK	21	3	63	2.5	52.5	0	0	52.5
MISCELLANEOUS FIXTURE	0	0	0	0	0	0	0	0
TOTAL FU			216.0		205.5		153.0	256.5

WATER AND WASTE SERVICE CALCULATIONS								
JOB NAME: EHA BAKER HEIGHTS BLDG C EAST			DATE: 03/02/20		USER: JEE			
JOB NUMBER: 20US00169								
FIXTURE TYPE	NO.	WASTE		COLD WATER		HOT WATER		TOTAL WATER
		FU	TOTAL	FU	TOTAL	FU	TOTAL	
BATH TUB/SHOWER	8	2	16	3	24	3	24	32
CLOTHES WASHER	8	3	24	3	24	3	24	32
KITCHEN SINK (DOMESTIC)	8	2	16	1.125	9	1.125	9	12
LAVATORY	8	1	8	0.75	6	0.75	6	8
WATER CLOSET, TANK	8	3	24	2.5	20	0	0	20
MISCELLANEOUS FIXTURE	0	0	0	0	0	0	0	0
TOTAL FU			88.0		83.0		63.0	104.0

WATER AND WASTE SERVICE CALCULATIONS								
JOB NAME: EHA BAKER HEIGHTS BLDG C WEST			DATE: 03/02/20		USER: JEE			
JOB NUMBER: 20US00169								
FIXTURE TYPE	NO.	WASTE		COLD WATER		HOT WATER		TOTAL WATER
		FU	TOTAL	FU	TOTAL	FU	TOTAL	
BATH TUB/SHOWER	15	2	30	3	45	3	45	60
CLOTHES WASHER	15	3	45	3	45	3	45	60
KITCHEN SINK (DOMESTIC)	15	2	30	1.125	16.875	1.125	16.875	22.5
LAVATORY	15	1	15	0.75	11.25	0.75	11.25	15
WATER CLOSET, TANK	15	3	45	2.5	37.5	0	0	37.5
MISCELLANEOUS FIXTURE	0	0	0	0	0	0	0	0
TOTAL FU			165.0		155.6		118.1	195.0

WATER AND WASTE SERVICE CALCULATIONS								
JOB NAME: EHA BAKER HEIGHTS BLDG D EAST			DATE: #####		USER: JEE			
JOB NUMBER: 20US00169								
FIXTURE TYPE	NO.	WASTE		COLD WATER		HOT WATER		TOTAL WATER
		FU	TOTAL	FU	TOTAL	FU	TOTAL	
BATH TUB/SHOWER	9	2	18	3	27	3	27	36
CLOTHES WASHER	8	3	24	3	24	3	24	32
KITCHEN SINK (DOMESTIC)	8	2	16	1.125	9	1.125	9	12
LAVATORY	9	1	9	0.75	6.75	0.75	6.75	9
WATER CLOSET, TANK	9	3	27	2.5	22.5	0	0	22.5
MISCELLANEOUS FIXTURE	0	0	0	0	0	0	0	0
TOTAL FU			94.0		89.3		66.8	111.5

WATER AND WASTE SERVICE CALCULATIONS								
JOB NAME: EHA BAKER HEIGHTS BLDG D WEST			DATE: 03/02/20		USER: JEE			
JOB NUMBER: 20US00169								
FIXTURE TYPE	NO.	WASTE		COLD WATER		HOT WATER		TOTAL WATER
		FU	TOTAL	FU	TOTAL	FU	TOTAL	
BATH TUB/SHOWER	21	2	42	3	63	3	63	84
CLOTHES WASHER	15	3	45	3	45	3	45	60
KITCHEN SINK (DOMESTIC)	15	2	30	1.125	16.875	1.125	16.875	22.5
LAVATORY	21	1	21	0.75	15.75	0.75	15.75	21
WATER CLOSET, TANK	21	3	63	2.5	52.5	0	0	52.5
MISCELLANEOUS FIXTURE	0	0	0	0	0	0	0	0
TOTAL FU			201.0		193.1		140.6	240.0

PLUMBING FIXTURE SCHEDULE

TAG	FIXTURE	MANUFACTURER	MODEL	ADA (Y/N)	FLOW (GPF/GPM)	CONNECTION SIZE				ELECTRICAL			REMARKS	
						W	V	HW	CW	V	PH	A		
GENERAL														
FD-2	FLOOR DRAIN - MECH	ZURN	Z520		0	4"	0"	0"	0"	0	0	0	0	9" DIAM CAST IRON BODY WITH ADJUSTABLE STRAINER.
FS-1	FLOOR SINK	ZURN	Z1900		0	4"	0"	0"	0"	0	0	0	0	12" x 12" X 6" FLOOR SINK W/ ACID RESISTANT COATING.
L-2	LAVATORY COUNTERTOP ADA	KOHLER	K-2905 FARMINGTON		0	1 1/2"	1 1/2"	1/2"	1/2"	0	0	0	0	Faucet K-7443 TRITON WITH AERATOR AND 4" WRIST BLADE HANDLES, OFFSET DRAIN ASSEMBLY, CARRIER SUPPORT.
MS-1	SERVICE SINK	KOHLER	K-12794		0	3"	3"	3/4"	3/4"	0	0	0	0	K-12794 HOLLISTER FAUCET K-13328 FINESSE WITH VACUUM BREAKER PROVIDE REINFORCEMENT FOR WALL SUPPORTS.
S-3	SINK	ELKAY	LRAD-3321		0	2"	1 1/2"	1/2"	1/2"	0	0	0	0	DOUBLE BOWL ADA COMPLIANT SINK W/ LK-4103 FAUCET WITH SPRAY, LK-35L STRAINER PROVIDE VALVE AND SUPPLY TUBING FOR COFFEE MAKER.
S-4	SINK	ELKAY	LRAD-3321		0	2"	1 1/2"	1/2"	1/2"	0	0	0	0	DOUBLE BOWL ADA COMPLIANT SINK W/ LK-4103 FAUCET WITH SPRAY, LK-35L STRAINER PROVIDE VALVE AND SUPPLY TUBING FOR COFFEE MAKER.
TP-1	TRAP PRIMER	PPP	P-2		0	0"	0"	0"	1/2"	0	0	0	0	PRESSURE DROP TYPE TRAP PRIMER.
WB-1	WASHER BOX	GUY GRAY	BB200TS		0	2"	1 1/2"	1/2"	1/2"	0	0	0	0	
WC-3	WATER CLOSET FLOOR MTD ADA (FV)	KOHLER	KINGSTON K-4325	YES	1.28	4"	2"	0"	1 1/4"	0	0	0	0	1.28 GALLONS PER FLUSH (GPF), BEMIS 1655-SSC SEAT, ZURN 6000XLWS-1 FLUSH VALVE.
WC-4	WATER CLOSET FLOOR MTD (FV) ADA	KOHLER	KINGSTON K-4325	YES	1.28	4"	2"	0"	1 1/4"	0	0	0	0	1.28 GALLONS PER FLUSH (GPF), BEMIS 1655-SSC SEAT, ZURN 6000XLWS-1 FLUSH VALVE.
RESIDENTIAL														
BT-1	BATH TUB	STERLING	ENSEMBLE	YES	1.75	2"	12 1/2"	1/2"	1/2"	0	0	0	0	
L-1	LAVATORY COUNTERTOP ADA	KOHLER	K-2905 FARMINGTON	YES	0	1 1/2"	1 1/2"	1/2"	1/2"	0	0	0	0	Faucet K-7443 TRITON WITH AERATOR AND 4" WRIST BLADE HANDLES, OFFSET DRAIN ASSEMBLY, CARRIER SUPPORT.
S-1	SINK	ELKAY	LRAD-1517	NO	0	2"	1 1/2"	1/2"	1/2"	0	0	0	0	AMERICAN STANDARD HERITAGE 7400.172H FAUCET, WRIST BLADE HANDLES.
S-2	SINK	ELKAY	LRAD-1517	YES	0	2"	1 1/2"	1/2"	1/2"	0	0	0	0	ADA COMPLIANT SINK AMERICAN STANDARD HERITAGE 7400.172H FAUCET, WRIST BLADE HANDLES.
WC-1	WATER CLOSET FLOOR MTD FLUSH TANK (FT)	AMERICAN STANDARD	CADET PRO 215CB.104	NO	1.28	4"	2"	0"	1/2"	0	0	0	0	1.28 GALLONS PER FLUSH (GPF), BEMIS 1655-SSC SEAT.
WC-2	WATER CLOSET FLOOR MTD FLUSH TANK (FT)	AMERICAN STANDARD	CADET PRO 215CB.104	NO	1.28	4"	2"	0"	1/2"	0	0	0	0	1.28 GALLONS PER FLUSH (GPF), BEMIS 1655-SSC SEAT.

- NOTES:
- COMPLY WITH ALL MANUFACTURER INSTALLATION REQUIREMENTS TO PROVIDE COMPLETE AND OPERATIONAL FIXTURES.
 - PROVIDE TRANSITION FITTING AS REQUIRED TO CONNECT TO BRANCH PIPING, WHICH MAY BE A DIFFERENT SIZE, AND AS SHOWN ON DRAWINGS.
 - PROVIDE STOP VALVES, BACKFLOW PREVENTERS AND SUPPORTS AS REQUIRED BY THE MANUFACTURER AND PLUMBING CODE.
 - COORDINATE WITH ELECTRICAL DESIGN FOR POWER SUPPLY AND LOCATIONS.
 - HOT WATER SHALL BE LIMITED TO ALL FIXTURES IN ACCORDANCE WITH ASSE STANDARDS: PUBLIC LAVATORIES, BATHTUBS & WHIRLPOOLS SHALL BE LIMITED TO 110 F (ASSE 1070), EMERGENCY EYEWASH AND SHOWERS LIMITED TO 60-100F (ASSE 1071), AND SINGLE SHOWER/ GANG SHOWERS LIMITED TO 120F (ASSE 1016/ ASSE 1069).

DOMESTIC WATER HEATER SCHEDULE

TAG	TAG #	MANUFACTURER	MODEL	LOCATION	VOL (GAL)	RECOV (GPH)	EWT (°F)	LWT (°F)	CONNECTION SIZE				NATURAL GAS		ELECTRICAL				UNIT SIZE (L"xW"xH")	OPER. WT. (LBS)	NOTES	
									CW (IN)	HW (IN)	NG (IN)	FLUE (IN)	INPUT (MBH)	EFF (AFUE%)	KW	VOLTS	PH	MCA				
BUILDING A																						
GWH	4.2	AO SMITH	BTH 150	LEVEL 4	100	198	50	140	3/4"	3/4"	+3/4"	4"	150	5	0.6	120	1	0			1420	1,2
GWH	4.1	AO SMITH	BTH 150	LEVEL 4	100	198	50	140	3/4"	3/4"	+3/4"	4"	150	95	0.6	120	1	0			1420	1,2
BUILDING B																						
EWH	#.X	AO SMITH	DEN 52	UNIT	50	34	50	120	3/4"	3/4"	+0"	0"		0	6	208	1	0			470	1,3
BUILDING C																						
EWH	E.#.X	AO SMITH	DEN 52	UNIT	50	34	50	120	3/4"	3/4"	+0"	0"		0	6	208	1	0			470	1,3,4
EWH	W.#.X	AO SMITH	DEN 52	UNIT	50	34	50	120	3/4"	3/4"	+0"	0"		0	6	208	1	0			470	1,3,4
BUILDING D																						
EWH	E.#.X	AO SMITH	DEN 52	UNIT	50	34	50	120	3/4"	3/4"	+0"	0"		0	6	208	1	0			470	1,3,4
EWH	W.#.X	AO SMITH	DEN 52	UNIT	50	34	50	120	3/4"	3/4"	+0"	0"		0	6	208	1	0			470	1,3,4

- NOTES:
- COORDINATE WITH ELECTRICAL FOR POWER AND DISCONNECT AS REQUIRED.
 - CONDENSING TANK TYPE WATER HEATER, NATURAL GAS INPUT. PROVIDE CONCENTRIC AIR INTAKE AND EXHAUST FITTING. PROVIDE CPVC VENT PIPING.
 - ELECTRIC TANK TYPE WATER HEATER.
 - WITHIN TAG # COLUMN, # INDICATES FLOOR LEVEL, X INDICATED QUANTITY IDENTIFIER. X TO MATCH CW RISER NUMBER PER PLAN.

PLUMBING EXPANSION TANK SCHEDULE

TAG	#	MANUFACTURER	MODEL	LOCATION	TYPE	TANK VOL. (GAL)	ACCEPT. VOL. (GAL)	SYSTEM VOL. (GAL)	FILL PRESS. (PSIG)	OPER. PRESS. (PSIG)	RELIEF PRESS. (PSIG)	MIN. TEMP. (°F)	MAX. TEMP. (°F)	SYSTEM CONN. (IN)	NOTES
T	4.1	WATTS	DETA - 30	LEVEL 4	BLADDER	15	10	270	40	45	50	50	140	1"	
BUILDING B															
T	#.X	WATTS	PLT - 5	UNIT	DIAPHRAGM	2	0	0				50	120	3/4"	
BUILDING C															
T	E.#.X	WATTS	PLT - 5	UNIT	DIAPHRAGM	2	0	0				50	120	3/4"	
T	E.#.X	WATTS	PLT - 5	UNIT	DIAPHRAGM	2	0	0				50	120	3/4"	
BUILDING D															
T	W.#.X	WATTS	PLT - 5	UNIT	DIAPHRAGM	2	0	0				50	120	3/4"	
T	W.#.X	WATTS	PLT - 5	UNIT	DIAPHRAGM	2	0	0				50	120	3/4"	

DOMESTIC RECIRCULATION PUMP SCHEDULE

TAG	#	MANUFACTURER	MODEL	LOCATION	TYPE	FLOW (GPM)	HEAD (FT WG)	RPM	CONNECTION SIZE (IN)	ON/OFF SETPOINT (°F)	ELECTRICAL			NOTES
											HP	WATTS	VOLTS PH	
HWCP	4.1	B&G	ECO CIRC-XL	LEVEL 4	CIRCULATOR	0		0	3/4"	110		115	1	

NOTES:

- COORDINATE WITH ELECTRICAL FOR POWER AND DISCONNECT AS REQUIRED

SECTION 018316
EXTERIOR ENCLOSURE PERFORMANCE REQUIREMENTS

PART 1 - GENERAL

1.1 SUMMARY

- A. Section Includes:
1. Administrative and procedural requirements for accomplishing airtight building and dwelling unit enclosures that control infiltration or exfiltration of air.
 2. Building envelope air barrier is intended to control air leakage in and out of building as a whole.
 3. Compartmentalization focuses on air tightness of individual residential units, addressing air sealing of walls, floors, ceilings, and transitions between them.

1.2 DEFINITIONS

- A. Air Barrier: Materials assembled and joined together to provide a barrier to air leakage through building envelope. Minimizes air leakage from interior spaces along building perimeter to exterior.
- B. Compartmentalization: Materials assembled and joined together to provide barrier to air leakage between dwelling units. Minimizes air leakage from dwelling units to exterior and adjacent interior space.

1.3 ADMINISTRATIVE REQUIREMENTS

- A. Organize separate preconstruction meetings between trades involved in the building air barrier system and b) the unit compartmentalization system to clearly communicate the intent of each system, discuss where each trade begins and ends, the responsibility and sequence of installation of all the air-tight joints, junctures, and transitions between materials, products and assemblies of products specified in the different sections to be installed by the different trades, the quality standards required, and quality control measures that will be applied.

1.4

- A. Air Barrier System shall have the following characteristics:
1. Continuous, with joints sealed.
 2. Structurally supported to withstand positive and negative air pressures applied to building enclosure.
 3. Connections between:
 - a. Foundation and walls.
 - b. Walls and windows or doors.
 - c. Different wall systems.
 - d. Wall and roof.
 - e. Wall and roof over unconditioned space.
 - f. Walls, floors, and roof across construction, and control and expansion joints.
 - g. Walls, floors, and roof to utility, pipe, and duct penetrations.
 - h. Walls separating garage space from interior space.
 - i. Walls, floors, and roof separating conditioned space from unconditioned space.
 - j. Walls, floors, and roof separating one dwelling unit from another interior or exterior space.
 4. Penetrations: Ensure penetrations of air barrier and paths of air infiltration or exfiltration are air-tight.

- B. Compartmentalization System shall have the following characteristics in addition to Air Barrier System Requirements above:
 - 1. Compartmentalization consists of both exterior surfaces that make up building envelope, party walls, corridors, floors, and ceilings that enclose each unit.
 - 2. Continuous, with joints sealed.
 - 3. Structurally supported to withstand positive and negative air pressures applied to building enclosure.
 - 4. Connections between:
 - a. Walls and windows or doors.
 - b. Different wall systems.
 - c. Floors and walls.
 - d. Walls and slabs, including between top of wall and bottom of slab or subfloor, above suspended ceilings.
 - e. Walls and ceilings, including between top of wall and bottom of slab or subfloor, above suspended ceilings.
 - f. Walls, floors, and ceilings adjacent to utility and circulation shafts.
 - g. Walls, floors, and roof separating one dwelling unit from another interior or exterior space.
 - 5. Penetrations: Ensure penetrations of air barrier are air-tight.
 - a. Penetrations may include electrical and low-voltage/communications outlets, ventilation systems, plumbing penetrations, and other similar penetrations..
 - 6. Soffits and framed voids sealed to prevent air transfer between units.
 - 7. Gaps and Openings: Install joint sealants to provide complete seal at holes in air barrier created by pipes, wires, ducts, windows, doors, access doors and panels, electrical fixtures, and similar penetrations.
- C. Inspection and testing services will be required to verify compliance with requirements specified or indicated. These services do not relieve Contractor of responsibility for compliance with Contract Document requirements.
- D. Requirements of this Section relate to coordination between Subcontractors to provide an airtight building enclosure, customized fabrications, and installation procedures. It does not apply to production of standard products.

1.5 CONTRACTOR RESPONSIBILITIES

- A. Unless indicated otherwise, provide coordination of trades and sequence of construction to ensure continuity of system joints, junctures, and transitions between materials and assemblies of materials and products, from substructure, to walls, to roof.
- B. Cooperate with agencies performing required inspections, tests, and similar services, and provide reasonable auxiliary services as requested. Provide auxiliary services required include the following:
 - 1. Provide access to the Work.
 - 2. Furnish labor and facilities necessary to facilitate inspections and tests.
 - 3. Provide security and protection of test equipment at Project Site.
- C. Coordinate sequence of activities to accommodate required services with minimum delay. Coordinate activities to avoid necessity of removing and replacing construction to accommodate inspections and tests.
- D. At the earliest possible time, but after the first completed installation of framing, gypsum wallboard, and electrical and mechanical rough-in, coordinate with testing agency for an in place mockup test of unit compartmentalization performance. Test results may be used to modify construction practices to resolve any deficiencies in whole building envelope or unit enclosures.

1.6 PERFORMANCE CRITERIA

- A. Building A: Building Envelope Air Barrier Requirement:
 - 1. Air leakage through building envelope shall not exceed 0.25 cfm/sq. ft. of building enclosure at 75 pascals differential pressure when tested according to ASTM E779 following multi-point test protocol outlined in Washington State Energy Code and Army Corps of Engineers Whole Building Air Leakage Test Protocol.
 - 2. Test protocol may use pressurization only, or average of pressurization and depressurization test results.
- B. Buildings B, C, and D: Building Envelope Air Barrier Requirement: Compliance based on R402.4.1.2:
 - 1. Reduce tested air leakage to 3.0 air changes per hour maximum.

PART 2 - PRODUCTS

2.1 MATERIALS

- A. Materials specified that make up air barrier and compartmentalization systems of building to be inspected and tested include:
 - 1. Section 033000 – Cast in Place Concrete.
 - 2. Section 033816 – Unbonded Post-Tensioned Concrete.
 - 3. Section 042000 – Unit Masonry.
 - 4. Section 061000 – Rough Carpentry.
 - 5. Section 061600 – Sheathing.
 - 6. Section 071700 – Bentonite Waterproofing.
 - 7. Section 072100 – Thermal Insulation.
 - 8. Section 072129 – Foamed-in-Place Insulation.
 - 9. Section 072500 – Weather Barriers.
 - 10. Section 072713 – Modified Bituminous Sheet Air Barriers.
 - 11. Section 072715 – Nonbituminous Self-Adhering Sheet Air Barriers.
 - 12. Section 072723 – Board Product Air Barriers.
 - 13. Section 072726 – Fluid-Applied Membrane Air Barriers.
 - 14. Section 073013 – Roofing Underlayments.
 - 15. Section 073113 – Asphalt Shingles.
 - 16. Section 075216 – SBS Modified Bituminous Membrane Roofing.
 - 17. Section 075423 – Thermoplastic Polyolefin (TPO) Roofing.
 - 18. Section 075552.16 – SBS Modified Bituminous Protected Membrane Roofing.
 - 19. Section 076200 – Sheet Metal Flashing and Trim.
 - 20. Section 076500 –Flexible Flashing.
 - 21. Section 079200 – Joint Sealants.
 - 22. Division 08 Sections for exterior door, window, skylight, and other openings.
 - 23. Section 092216 – Non-Structural Metal Framing.
 - 24. Section 092000 – Gypsum Board.
 - 25. Section 099000 – Painting and Coating.

2.2 DESCRIPTION

- A. Regulatory Requirements:
 - 1. Air Barrier System Performance is mandated by Washington State Energy Code and building level efficiency option C406.9 Reduced Air Infiltration, and as described on Drawings.
 - 2. ESDS 5.1a Building Performance Standard – New Construction (Mandatory).
 - a. Building A – Comply with 2015 WSEC C406.9.
 - b. Buildings B, C and D – Comply with Option 2a From Table R406.2 of the 2015 WSEC.

PART 3 - EXECUTION

3.1 REPAIR AND PROTECTION

- A. Upon completion of inspection, testing, sample taking, and similar services, repair damaged construction and restore substrates and finishes.
- B. Repair and protection is contractor's responsibility, regardless of the assignment of responsibility for inspection, testing, or similar services.

3.2 FIELD QUALITY CONTROL

- A. Owner will hire inspection agency / agencies to provide periodic observation and inspection during installation of the air barrier and compartmentalization systems. The agency/ies will provide reports of the observations to the owner with copies to the architect and contractor.
- B. The inspection agency/ies will review a representative sample of components of the air barrier and compartmentalization system, including, but not limited to the following:
 - 1. Building Envelope Air Barrier
 - a. Continuity of the air barrier.
 - b. Structural support of the air barrier.
 - c. Site conditions for application temperature and dryness of substrates.
 - d. Maximum length of exposure time of materials.
 - e. Surfaces are properly prepared, primed, etc.
 - f. Laps in material are appropriate, shingled in the correct direction, with no fish mouths or wrinkles.
 - g. Mastic applied on cut edges of self-adhered membranes as required.
 - h. Roller has been used to promote adhesion.
 - i. Measurements of the thickness of liquid-applied materials to manufacturer's specifications for the specific substrate.
 - j. Connections between assemblies and materials (membrane and sealants) for proper substrate preparation, support, integrity, and continuity.
 - k. Penetrations sealed to the air barrier component.
 - 2. Unit compartmentalization air barrier
 - a. Alignment of framing to facilitate compartmentalization
 - b. Continuity of the air barrier.
 - c. Proper sealing of framing penetrations, j-boxes and other equipment prior to cover
 - d. Proper sealing of air barrier to installed equipment after cover
 - e. Proper sealing of plumbing and electrical penetrations

3.3 AIR LEAKAGE TESTING

- A. Owner is to engage a qualified testing agency/ies to perform a building envelope air barrier and unit compartmentalization air leakage tests at substantial completion of the building air barrier system.
- B. Whole Building Air Barrier Test: Separately test entire residential building and entire commercial space. Subject to approval by the building department, testing of a sampling of areas may be allowed. If portions need to achieve occupancy prior to completion of the entire building, coordinate scheduling and temporary sealing requirements at building separation walls with testing agency.
- C. Unit Compartmentalization Test: Test a representative sampling of residential units as determined at preconstruction meeting. Units shall be in final condition and temporary sealing of enclosures not allowed.
- D. Test Preparation:
 - 1. Two weeks in advance of testing, Contractor shall coordinate a pre-testing walkthrough with the testing agency and HVAC sub-contractor to discuss pre-test preparation required

- by the contractor. Contractors shall familiarize themselves with the test protocols and pre-testing preparation.
2. Two days prior to testing, the Contractor shall have all temporary enclosures in place for testing agency review and pre-testing to confirm all extraneous air leakage paths are sufficiently sealed off. Contractor shall undertake any re-sealing/modifications of temporary enclosures to the testing agencies satisfaction.
 3. For whole building testing, the Contractor is to provide temporary enclosures to seal all intentional functional openings such as exhaust and relief louvers, grilles, cooktop vents, dryer vents, and garbage chutes that are not used in the test to introduce air, using plastic sheeting and duct tape or similar materials based on guidance provided by the testing agency. For Compartmentalization testing, temporary seals not allowed.
 6. During scheduled testing, the Contractor shall provide the testing agency complete, uninterrupted access to the entire building for duration of the test.
 7. During testing, the Contractor shall coordinate with the fire department to have the fire alarm set in test mode.
 8. During testing, all HVAC systems shall be powered down for the duration of the test.
 9. Contractor shall control access during testing to prevent any unauthorized entrance/exit to the building.
 10. Areas being tested will have to be sealed off and as such no construction activities should be scheduled in this area during the day of the testing.
 13. All building enclosure and/or air barrier components and systems must be in their final condition including, but not limited to glazing (including door vision panels), gaskets, weatherstripping, hardware, thresholds, sweeps, and penetration seals.
 14. Contractor to provide dedicated electrical service as required by the testing agency for operation of equipment to perform whole building air leakage testing.

3.4 PROTECTION

- A. Protect construction exposed by or for quality-control service activities, and protect repaired construction during remainder of construction activities.

END OF SECTION 018316

SECTION 019100
GENERAL COMMISSIONING REQUIREMENTS

PART 1 - GENERAL

1.1 SUMMARY

- A. Section Includes:
 - 1. Duties of Contractor.
 - 2. Commissioning Authority.
 - 3. Commissioning Plan.
 - 4. Acceptance procedures.
 - 5. Performance period.
 - 6. Training and instruction.
- B. Related Requirements:
 - 1. Division 01 – Sustainable Design Requirements
 - 2. Division 21 -- Fire Sprinklers
 - 3. Division 22 – Plumbing Materials and Methods
 - 4. Division 23 – Mechanical Materials and Methods.
 - 5. Division 26 – Electrical Materials and Methods.
 - 6. Division 27 -- Low Voltage Systems

1.2 CODE REQUIREMENTS

- A. Commissioning shall comply with requirements of 2015 Washington State Energy Code. Commissioning shall include, as a minimum, the following:
 - 1. Commissioning Plan.
 - 2. System Testing and Balancing.
 - 3. Equipment Functional Performance Testing.
 - 4. Controls Functional Performance Testing.
 - 5. A Preliminary Commissioning Report.
 - 6. Post Construction Documentation.
 - 7. A Final Commissioning Report.

1.3 ESDS REQUIREMENTS

- A. Commissioning shall comply with ESDS 1.3b Commissioning including obtaining 6 points

1.4 TERMS

- A. Commissioning Plan: Preliminary Commissioning Plan has been prepared by Commissioning Authority (CA), is included in this Section, and shall be implemented by Contractor and CA together. Commissioning plan outlines organization, scheduling, documentation, etc., pertaining to overall commissioning process. A final Commissioning Plan shall be prepared after Contract Award as described below.
- B. Functional Performance Testing: That full range of checks and tests carried out to determine if components, sub-systems, systems, and interfaces between systems function in accordance with Contract Documents. In this context, "function" includes modes and sequences of control operation, interlocks and conditional control responses, and specified responses to abnormal emergency conditions. Functional Performance Testing will be done in Phases, contingency plans will be planned to avoid disturbance to systems in operations in other Phases.

- C. Acceptable Performance: A component or system being able to meet specified design parameters under actual load including satisfactory documented completion of functional performance tests, control system trending, and resolution of outstanding issues.
- D. Commissioning: Process to assure Owner that mechanical and electrical equipment, controls, and systems function together properly to meet performance requirements and design intent as shown in a composite manner in Contract Documents.

1.5 DUTIES OF CONTRACTOR

- A. Collect and assemble information required for development of a complete Commissioning Plan and Functional Performance Test for systems to be commissioned and provide this information to Commissioning Authority. Review these documents. Confirm in writing to Owner, Architect, and Commissioning Authority known areas of conflict or areas requiring clarification.
- B. Review functional performance tests and documentation required by Contract Documents for equipment and systems of Project.
- C. Collect proposed start-up, Prefunctional performance and working in occupied space contingency plans documentation. Provide that information for review and approval by Commissioning Authority. Incorporate that information into Field Commissioning Notebook.
- D. Field Commissioning Notebook will be kept and managed by Contractor. Confirm in writing to Commissioning Authority that systems are complete, functional, and Prefunctional performance documentations signed.
- E. Participate in regular commissioning meetings with Architect and Commissioning Authority.
- F. Coordinate required Architect, Commissioning Authority, and Owner testing participation and approval procedures, after verifying that start-up and pretests have been satisfactorily conducted and final tests are ready to be performed.
- G. Perform functional performance tests.
- H. Review operation and maintenance data for verification, organization, distribution, and conformance to requirement of Contract Documents.

1.6 COMMISSIONING AUTHORITY

- A. Owner will contract directly with a Commissioning Authority to direct commissioning process through appropriate contract channels, witness functional performance test, and recommend Project completion from commissioning perspective.
- B. Duties of Commissioning Authority are as follows.
 - 1. Develop Commissioning Plan.
 - 2. Develop both a Phasing and Final completed systems Functional Test Procedure from final control documentation including narrative sequences of operation, as-built control diagrams, and software code for execution with assistance of Contractor's staff as required.
 - 3. Develop Field Commissioning Notebook with appropriate documentation provided from Contractor. Provide supplemental documentation as necessary to ensure that aspects of start-up and testing have been completed and documented prior to functional performance testing.
 - 4. Witness and verify satisfactory completion of equipment and component tests and systems and inter-systems performance tests.
 - 5. Provide site observation, functional performance test, and other Project reports in a timely manner. Document inconsistencies or deficiencies in system operations and system compliance. Forward system deficiencies to Architect and track with normal punch listing activities.

6. Participate in development of schedules with Contractor for start-up and functional performance testing. This will be coordinated with required building Owner occupancy schedules and the Construction Phasing requirements by Owner.
 7. Coordinate, through Architect, participation of Owner's personnel involved with equipment, component, and systems performance verification and participation in required training.
 8. Witness functional performance tests.
 9. When commissioning has been successfully completed, recommend acceptance to Owner.
 10. Verify that appropriate operation and maintenance manuals and Project redline drawings have been provided.
 11. Once functional performance tests have been successfully completed and outstanding issues resolved, Commissioning Authority will provide Owner with a final report of commissioning activities that occurred during Project.
- C. Commissioning Authority will formally communicate with Contractor via approved Project channels. Records of contacts will be sent to Architect through normal channels.
- D. Commissioning Authority is not authorized to modify, add to, or revoke requirements of Contract Document. A change in Work can only be made as provided in General Conditions.

1.7 COMMISSIONING PLAN

- A. Commissioning Plan details implementation of commissioning process. It includes requirements that each party involved in commissioning process will have to accomplish, including sequence, documentation requirements, verification procedures, etc. Commissioning Plan will be provided by Commissioning Authority during Project execution.
1. Commissioning Plan shall include the following:
 - a. Preparation for Testing: To prepare for system functional performance testing, Commissioning Authority will examine design and Construction Documents, develop Prefunctional Checklists of construction responsibilities that shall be completed prior to testing, and develop detailed Functional Performance Test Procedures and data forms. Using Prefunctional Checklists, the Contractor shall verify that the systems installed comply with the construction documents and are fully functional. Commissioning is not intended to be a testing or inspection function that replaces any of the Contractors' obligations for testing and proof of performance. Functional performance testing will only begin when checklists are completed by Contractor, initialed, signed, and installed into the Field Commissioning Notebook accompanied with a written letter from the Contractor indicating specific system completion.
 - b. Functional Performance Testing: Functional performance testing will be witnessed by the Commissioning Authority to verify proper sequencing, operation, and performance of installed equipment and systems under realistic operating conditions. As tests are successfully completed, a functional performance test checklist will be used to document the testing progress.
 - c. Documentation: In addition to the Prefunctional Checklists and Functional Performance Test Procedures, written documentation will be maintained for other commissioning activities. Project communication reports shall be issued by the Commissioning Authority to Architect and key members of the commissioning team to document apparent deficiencies identified during examination of design and construction documents, daily activities on-site, construction deficiencies, and successful or unsuccessful functional performance testing results. These Project communication reports will also be kept in the Field Commissioning Notebook. At the end of the commissioning process, documentation will be assembled and summarized in the final commissioning report.
 - d. Problem Resolution: When a Project communication report is issued to address an identified deficiency, Architect will forward the reports to the appropriate parties to

initiate corrective action in an expeditious manner. Deficiencies will be tracked as part of the punch listing activity.

B. Commissioning Roles and Responsibilities:

1. Responsibilities for commissioning are divided between Architect, Contractor, and Commissioning Authority as follows:
 - a. Commissioning Responsibilities Related to Architect are:
 - 1) Review the commissioning documentation and provide comments as necessary.
 - 2) Participate in determination of final controls system I/O Points List and Sequences of Operation as required to complete functional performance test procedures with Commissioning Authority. Review the commissioning documentation and provide comments as necessary.
 - b. Commissioning Responsibilities Related to the Contractor:
 - 1) Contractor shall support the Commissioning Authority.
 - 2) Incorporate commissioning activities into the general construction schedule. The schedule shall identify Functional Performance Testing, as well as the initiation and completion of the Performance Period. This shall be coordinated with occupancy schedules required by Owner.
 - 3) Participate in regular commissioning meetings with Architect and Commissioning Authority
 - 4) Coordinate participation of Contractor and Commissioning Authority in the commissioning process through Architect
 - 5) Forward copies of submittals, operation and maintenance manuals, and as-built drawings to Architect.
 - 6) Review the Commissioning Plan, Functional Performance Test Procedures, Project communication reports, and Prefunctional Checklist reports, and submit comments to the Commissioning Authority through Architect.
 - 7) Address issues identified during construction that may affect the commissioning process or final system performance expeditiously.
 - 8) Forward completed Prefunctional Checklist and Start-up documentation to the Commissioning Authority through Architect in a timely manner. Provide the Commissioning Authority written notification of specific systems that are complete and ready for functional performance testing
 - c. Contractor's Commissioning Responsibilities Related to the Mechanical Systems are:
 - 1) Support the Commissioning Authority to ensure the adjacent areas that are not under construction are maintaining the required room pressure gradients, temperature control, and airflow.
 - 2) Coordinate installation of mechanical systems and equipment. Verify that coordination, installation, quality control, and testing have been completed such that installed systems and equipment comply with construction documents.
 - 3) Notify Architect and Commissioning Authority as soon as possible of any issues identified during construction that may affect the commissioning process or final system performance.
 - 4) Provide Commissioning Authority with proposed start-up and testing documentation to be used for the test documentation specified in Division 20, 21, 22, and 23.
 - 5) Perform start-up and testing of mechanical equipment and systems and document as required with start-up reports and completion of Prefunctional Checklists. Operate equipment and systems as required for functional performance testing.
 - 6) Participate in the fine-tuning or troubleshooting of system performance if either of these measures becomes necessary.
 - 7) Provide complete operation and maintenance information and as-built drawings.

- 8) Provide training for the systems specified.
- d. Contractor's Commissioning Responsibilities Related to Electrical Systems are:
 - 1) Coordinate installation of electrical systems and equipment. Verify that coordination, installation, quality control, and testing have been completed such that installed systems and equipment comply with construction documents.
 - 2) Provide Commissioning Authority wiring diagrams and narrative sequences of operation in time for use in preparing the Functional Performance Test Procedures.
 - 3) Notify Architect and Commissioning Authority immediately of any issues identified during construction that may affect the commissioning process or final system performance.
 - 4) Provide Commissioning Authority with proposed start-up and testing documentation to be used for the test documentation specified in Division 26.
 - 5) Perform start-up and testing of electrical equipment and systems and document with start-up reports and completion of Prefunctional Checklists. Operate equipment and systems as required for functional performance testing.
 - 6) Participate in fine-tuning and troubleshooting of system performance if either of these measures becomes necessary.
 - 7) Provide complete operation and maintenance information and as-built drawings.
 - 8) Provide training for the systems specified.
- e. Contractor's Commissioning Responsibilities Related to the Controls Systems are:
 - 1) Support the Commissioning Authority to ensure the adjacent areas that are not under construction are maintaining the required room pressure gradients, temperature control, and airflow.
 - 2) Provide Commissioning Authority with controls system and wiring diagrams and narrative sequences of operation, in time for use in preparing the Functional Performance Test Procedures.
 - 3) Review the Commissioning Plan, schedule, and Functional Performance Test Procedures. Provide input required to develop final plans and procedures that commissioning team members accept as a means of compliance with commissioning goals and the Project contract.
 - 4) Participate in any required efforts to finalize sequences of operations with Owner, Architects, and Commissioning Authority.
 - 5) Coordinate installation of controls system. Verify that coordination, installation, quality control, and testing have been complete such that installed systems and equipment comply with construction documents.
 - 6) Notify the Commissioning Authority, Architects, and Owner's Representative as soon as possible of any system installation issues identified during construction that may compromise system control capability.
 - 7) Participate in start-up and functional performance testing as required. This will require dedicated, full time support of the Commissioning Authority's functional performance testing efforts during commissioning.
 - 8) Complete Prefunctional Checklists and other supporting documentation as required to demonstrate completion of control system installation, point to point verification (including sensor calibration), start-up and testing. Reports shall be stored at the Project site.
 - 9) Participate in fine-tuning or troubleshooting of system performance if either of these measures becomes necessary.
 - 10) Provide the Commissioning Authority and Owner's Representative with final documentation for installed conditions, including as-built drawings and detailed narrative sequences of operation as determined during commissioning process.

- f. Commissioning Responsibilities Related to Commissioning Authority are:
 - 1) Perform commissioning submittal review to verify suitability and compliance with specifications.
 - 2) Revise Commissioning Plan as necessary to incorporate post-award conditions.
 - 3) Provide supplemental Prefunctional Checklist documentation forms for equipment to be commissioned with coordination of specified documentation. Documentation will be coordinated by the Commissioning Authority and installed in a Field Commissioning Notebook. That notebook shall be maintained and managed the by Contractor.
 - 4) Organize meetings to finalize the controls system I/O Points List and Sequences of Operation. The meeting will be supported by Architect and Contractor.
 - 5) Write Functional Performance Test Procedures and transmit to Contractor for review. After review period, changes will be incorporated and test will be performed.
 - 6) Perform site observations to follow installation progress and to verify system installation quality and readiness for testing.
 - 7) Observe the start-up activities and initial testing of equipment and systems as required, and review start-up documentation. Verify that the specified training schedule of Owner's personnel is provided.
 - 8) Review submittal of required Prefunctional Check list and start-up documentation for completeness and reasonableness. This includes point to point checklists and the TAB Work has been completed and the preliminary TAB report is provided to the Commissioning Authority prior to initiation of functional performance testing.
 - 9) Witness functional performance test.
 - 10) Issue Project communication reports as necessary to document activities, progress, and deficiencies.
 - 11) Assemble test results and other required documentation into the final commissioning report.

C. Commissioning Process:

- 1. Coordination:
 - a. Meetings:
 - 1) Commissioning issues pertaining to overall construction process will be raised at regular construction meetings. As Project advances into system start-up and testing phases, commissioning coordination meetings will be scheduled on an as-needed basis. Commissioning Authority will lead commissioning meetings. Minutes of these coordination meetings will be taken by Architect and distributed to appropriate parties
 - b. Scheduling:
 - 1) Incorporate commissioning related tasks noted throughout this Section into overall construction schedule. The intent is to define milestones that must be achieved before various commissioning activities can commence. General flow of commissioning process is as described in this Section and in Commissioning Implementation Flowchart provided in final Commissioning Plan.
- 2. Preparation for Functional Performance Testing:
 - a. Mechanical and Electrical System Installation:
 - 1) As installation of mechanical equipment and piping is completed, clean and test systems for integrity. Provide electrical connections to each piece of equipment and control element installation and wiring is to be completed.

- b. System Point-to-Point Check:
 - 1) Perform point-to-point testing of control components as specified in Construction Documents. Procedures and methods for this testing will be reviewed by Commissioning Authority. Checkout may be witnessed by Commissioning Authority or other appropriate parties.
 - c. System Start-up:
 - 1) As described above, under roles and responsibilities, Contractor shall start up equipment in their portion of the Specifications. This task may be witnessed by Commissioning Authority or other appropriate parties.
 - d. Verification of Completion:
 - 1) As each of the above successive steps is completed of Project, complete appropriate Prefunctional Checklists and related specified documentation. Together with written statement of acceptance noted in Specifications, these forms will be Contractors statement that Contractor's Work on the system is complete. Completion of Prefunctional Checklists shall indicate that systems are installed, cleaned, integrity tested, wired lot power and control, started, balanced, and ready to commission.
3. Functional Performance Testing:
- a. Test Strategy:
 - 1) Functional performance testing is to verify proper sequencing, operation, and performance of equipment and systems over a realistic range of operating conditions. Once basic system start-up and operation is verified by Contractor, actual functional performance testing can commence. For each subsystem, control system shall be exercised to verify proper operation of control sequence. Installed capacities of each subsystem and its component equipment shall be verified as appropriate. Finally, entire mechanical system control sequence shall be tested and overall system capacity verified.
 - b. Test Procedures:
 - 1) Detailed functional performance test procedures shall be written by Commissioning Authority for overall mechanical system, each subsystem, and each component to be tested. These procedures shall be submitted to Architect for distribution. Functional performance testing shall be witnessed by Commissioning Authority. Test shall cover sequences and components of systems. Once systems have been completed and tested, Commissioning Authority will verify correct operation.
4. Documentation:
- a. Project Communication Reports and Log:
 - 1) Project communication reports shall be issued by Commissioning Authority to Architect to inform involved parties and document the following issues.
 - a) Daily commissioning activities and progress on site.
 - b) Deficiencies identified in design and Construction Documents.
 - c) Deficiencies identified in installation.
 - d) Successful or unsuccessful results of functional performance testing
 - b. Final Commissioning Report:
 - 1) Commissioning Authority will assemble the following documentation into a final report to be submitted to Architect.
 - a) Project Summary.
 - b) Prefunctional Checklists and Supplemental Documentation (includes Controls point to point documentation and TAB preliminary report).
 - c) Functional Performance Test Procedures.
 - d) Functional Performance Test Records.
 - e) Project Communication Reports and Log.

- c. As-Built Documentation:
 - 1) Commissioning Authority shall review as-built documentation for accuracy and completeness including Construction Drawings, Shop Drawings, operation and maintenance literature, and control system submittals. Contractor shall organize documentation. These documents are a necessary reference for Owner's operation and maintenance manual.
 - 5. Training:
 - a. Owner's operation and maintenance personnel shall be formally trained in classroom sessions after distribution of operation and maintenance manuals and after equipment start-up/commissioning. These sessions shall be performed as specified in pertinent Sections and as noted in final Training Matrix.
 - D. The functional performance test procedures include the following.
 - 1. Verification of equipment performance.
 - 2. Verification of the performance of subsystems consisting of combinations of equipment (e.g. refrigeration cycle, pumps, chillers, and interconnecting piping).
 - 3. Verification of the performance of the automatic controls in seasonal modes.
 - 4. Verification of the performance of the HVAC system as a whole.
 - 5. Verification of the performance of life safety devices and systems as the interface with the HVAC systems.
- 1.8 FIELD COMMISSIONING NOTEBOOK
- A. The Field Commissioning Notebook will be used to identify and track pertinent commissioning documentation required during the installation phase. This Notebook shall be maintained by the Contractor on site. The Notebook provides a central location for the Commissioning Authority to identify, copy, and organize pertinent information and will include the following format.
 - 1. Summary describing Notebook contents and use.
 - 2. Copy of Commissioning Plan for Contractor field reference.
 - 3. Listing of Specification Section documentation requirements listed by Section, with sign off spots for appropriate parties.
 - 4. Tabs for each Section with copies of Prefunctional check sheets provided by coordination of Contractor and Commissioning Authority for Contractor completion and space for related Contractor-supplied documents.

PART 2 - PRODUCTS (NOT USED)

PART 3 - EXECUTION

3.1 GENERAL

- A. Operating equipment and systems shall be tested in presence of Owner's Commissioning Authority to demonstrate compliance with specified requirements.
 - 1. Notify Commissioning Authority and Architect, in writing, 3 working days prior to tests scheduled under requirements of this Section.
 - 2. Conduct testing under specified design operating conditions as recommended or approved by Commissioning Authority and Architect.
- B. Completion of Functional Performance Testing and acceptance by Owner is a condition of Substantial Completion.
- C. Test elements of systems to demonstrate that total systems satisfy requirements of these Specifications. Perform testing on a hierarchical basis. Test each piece of equipment for proper operation, followed by each subsystem, followed by entire system, followed by inter-ties to other major systems.

- D. Provide special testing materials and equipment.
- E. Acceptance Documentation: Include a copy of Commissioning Plan and Functional Performance Test results with each copy of Operations and Maintenance Manual.

3.2 SYSTEMS TO BE COMMISSIONED

- A. Exhaust Fans
- B. Pressurization Fans
- C. Smoke Exhaust Fans
- D. VAV Systems
- E. Electric Wall Mounted Heaters
- F. Electric Unit Heaters
- G. Variable Frequency Drives
- H. Fluid Cooler
- I. Boiler
- J. Pumps
- K. Variable Refrigerant System
- L. Indoor Heat Pump System
- M. DDC Control System
- N. Domestic Hot Water System
- O. Lighting Control System
- P. Daylighting Control System

3.3 ACCEPTANCE PROCEDURES

- A. Prior to functional performance testing of each system, Commissioning Authority shall observe and verify that physical installation of components and systems being tested is substantially installed in accordance with Contract Documents.
- B. Contractors Tests:
 - 1. Check systems for proper installation, and adjust and calibrate to verify that it is ready to function as specified.
 - 2. Check systems to verify that they have been installed properly and that connections have been made correctly.
 - 3. Check discrete elements and sub-systems for proper operation, and make necessary adjustments.
 - 4. Start-up and Operational Tests shall be complete, with required prefunctional checklist documentation included in Field Commissioning Notebook submitted for review by Commissioning Authority within 5 days of each activity, prior to starting Functional Performance Acceptance Tests.

- C. Functional Performance Tests:
 - 1. Objective of these tests is to demonstrate that system is operating and complying with specified performance requirements.
 - 2. Functional Performance Tests shall be performed on both phased and complete systems. Each function shall be demonstrated on paragraph-by-paragraph basis of Commissioning Authority written test procedure, developed to demonstrate conformance to requirements of Contract Specifications.
 - 3. Conduct actual testing program in accordance with prior approved procedures and document as required herein.
 - D. Functional performance testing process shall be accomplished for equipment, subsystems, systems, and system interfaces. These must be tested in each phase for acceptances, and there shall be a separate checklist for each to ensure documentation specific to each is complete.
 - E. Operate each system through all modes of system operation (for example, seasonal, occupied, unoccupied, warm-up, cool-down, etc., as applicable) including every individual interlock and conditional control logic control sequences, both full-load and part-load conditions, and simulation of abnormal conditions for which there is a specified system or controls response.
 - F. Temporary upsets of systems, such as distribution fault, control loss, setpoint change, equilibrium upset, and component failure, shall be imposed at different operation loads to determine system stability and recovery time.
 - G. When functional performance of individual systems has been proven, interface or coordinated responses between systems shall be checked. Systems involved may be within overall HVAC Work, or they may involve other systems, such as emergency systems for life safety.
 - H. Corrective Measures: If acceptable performance cannot be achieved, then necessary corrective measures shall be carried out by the Contractor. Every check or test for which acceptable performance was not achieved shall be repeated after the necessary corrective measures have been completed. This re-testing process should be repeated until acceptable performance is achieved.
- 3.4 PERFORMANCE PERIOD
- A. Initially test systems as independent building systems, followed by tests of systems tied into systems.
 - B. Upon Contractor's completion of requirements of Commissioning Plan, successful completion of Performance Period, and receipt of required documentation, Commissioning Authority shall provide Owner with a statement of acceptable performance. Receipt of acceptable performance statement by Owner shall be a condition of Final Completion of Project.
 - C. Initiate trend logs on DDC system for new systems and equipment.

3.5 TRAINING AND INSTRUCTION

- A. Training and instruction of Owner's personnel is a part of commissioning process and essential for proper operation of facility. Coordinate commissioning activities with training of Owner's personnel. Detailed requirements for training and instruction are contained in other Sections of Contract Documents Division 01, 20, 21, 22, 23, and 26.
- B. Training shall include, at a minimum, functional and maintenance training of equipment and systems for Owner's Operation and Maintenance staff, and training of building occupants regarding optimal operation of commissioned systems with which they interface.

END OF SECTION 019100

SECTION 015713

DEMOLITION

PART 1 - GENERAL

1.1 DESCRIPTION

- A. Section includes salvaging, removing, and disposing of materials as indicated on the plans or directed by the Engineer. The work also includes the backfilling of trenches, holes or pits that result from such removals.
- B. Related Sections
 - 1. 015713 – Temporary Erosion and Sediment Controls
 - 2. 310000 – Earthwork
 - 3. 311100 – Clearing and Grubbing

1.2 STANDARD SPECIFICATIONS

- A. All work to be performed and materials to be used shall be in accordance with the 2020 Standard Specifications and Standard Plans for Road, Bridge and Municipal Construction, as published by the Washington State Department of Transportation (WSDOT), as modified by the City of Everett Design and Construction Standards and Specifications for Development; latest edition.
- B. The Contractor shall have one copy of the Standard Specifications and Standard Plans at the job site.
- C. The Standard Specifications apply only to performance and materials and how they are to be incorporated into the work. The legal/contractual relationship sections and the measurement and payment sections do not apply to this document.

PART 2 - PRODUCTS (NOT USED)

PART 3 - EXECUTION

3.1 GENERAL REQUIREMENTS

- A. With certain exceptions, the Contractor shall raze, remove and dispose of all buildings and foundations, structures, fences and other obstructions that lie wholly or partially within the clearing limits. The exceptions are utility-owned equipment, items indicated to remain on the plans, and any other items the Owner may direct the Contractor to leave intact. The Contractor shall:
 - 1. Remove foundations completely.
 - 2. Break up basement floors to promote drainage.
 - 3. Fill basements or other cavities left by the removal of structures. The fill shall match the level of the surrounding ground. Any such fill shall be compacted to meet the requirements of Section 310000 Earthwork.

4. Make a vertical saw cut between any existing improvements to remain and the portion to be removed.
 5. Replace at no expense to the Owner any existing improvements to remain that are damaged during the removal of other improvements.
- B. When salvageable material is to remain the Owner's property, the materials identified shall be removed at the Owner's direction.
- C. Any material not named as the Owner's property will belong to the Contractor. The Contractor shall store or dispose of such material off-site in a safe and legal manner at no expense to the Owner.

END OF SECTION 024100

SECTION 033000
CAST-IN-PLACE CONCRETE

PART 1 - GENERAL

1.1 SUMMARY

A. Section Includes:

1. Form-facing material for cast-in-place concrete.
2. Form liners.
3. Shoring, bracing, and anchoring.
4. Steel reinforcement bars.
5. Welded-wire reinforcement.
6. Cast-in-place concrete.
7. Concrete materials.
8. Mixture design.
9. Placement procedures.
10. Finishes.

B. Products Installed But Not Furnished Under This Section:

1. Anchor bolts, steel pipe sleeves, slotted-channel inserts, and wedge-type inserts indicated to be cast into concrete.
2. Steel weld plates and angles for casting into concrete for applications where they are not specified in other Sections.

1.2 ADMINISTRATIVE REQUIREMENTS

A. Preinstallation Meeting: Conduct meeting at Project site.

1. Before submitting design mixtures, review concrete design mixture and examine procedures for ensuring quality of concrete materials. Require representatives of each entity directly concerned with cast-in-place concrete to attend, including the following:
 - a. Contractor.
 - b. Contractor's superintendent.
 - c. Owner.
 - d. Architect.
 - e. Structural engineer.
 - f. Installer.
 - g. Manufacturer representatives.
 - h. Independent testing agency responsible for concrete design mixtures.
 - i. Ready-mix concrete manufacturer.
 - j. Concrete Subcontractor.
 - k. Special concrete finish Subcontractor.
2. Review Project schedule, special inspection and testing and inspecting agency procedures for field quality control, concrete finishes and finishing, cold- and hot-weather concreting procedures, curing procedures, construction contraction and isolation joints, and joint-filler strips, semirigid joint fillers, forms and form removal limitations, shoring and reshoring procedures, vapor-retarder installation, anchor rod and anchorage device installation tolerances, steel reinforcement installation, methods for achieving specified floor and slab flatness and levelness floor and slab flatness and levelness measurement, concrete repair procedures, and concrete protection.

1.3 ACTION SUBMITTALS

- A. Product Data: For each type of product.

1. Portland cement.
 2. Fly ash.
 3. Slag cement.
 4. Silica fume.
 5. Performance-based hydraulic cement
 6. Aggregates.
 7. Admixtures:
 - a. Include limitations of use, including restrictions on cementitious materials, supplementary cementitious materials, air entrainment, aggregates, temperature at time of concrete placement, relative humidity at time of concrete placement, curing conditions, and use of other admixtures.
 8.]Fiber reinforcement.
 9. Vapor retarders.
 10. Floor and slab treatments.
 11. Liquid floor treatments.
 12. Curing materials.
 13. Joint fillers.
 14. Repair materials.
- B. Sustainable Design Submittals:
1. Environmental Product Declaration (EPD): For each product. For use in Life-Cycle Assessment indicating compliance with LEED requirements
 2. Health Product Declaration (HDP): For each product.
 3. Sourcing of Raw Materials: Corporate sustainability report for each manufacturer.
 4. Laboratory Test Reports: For curing and sealing compounds **[and] [liquid floor treatments]**, indicating compliance with requirements for low-emitting materials.
- C. Design Mixtures: For each concrete mixture, include the following:
1. Mixture identification.
 2. Minimum 28 day compressive strength.
 3. Durability exposure class.
 4. Maximum w/c ratios.
 5. In-situ carbon dioxide (CO₂) mineralization.
 6.]Slump limit.
 7. Air content.
 8. Nominal maximum aggregate size.
 9. Synthetic micro-fiber content.
 10. Indicate amounts of mixing water to be withheld for later addition at Project site.
 11. Alternate design mixtures when characteristics of materials, Project conditions, weather, test results, or other circumstances warrant adjustments.
- D. Shop Drawings: Prepared by or under supervision of a qualified professional engineer.
1. Formwork: Detail fabrication, assembly, and support of formwork.
 - a. Shoring and Reshoring: Indicate proposed schedule and sequence of stripping formwork, shoring removal, and reshoring installation and removal.
 2. Concrete Forming and Accessories:
 - a. For exposed vertical concrete walls, indicate dimensions and form tie locations.
 - b. Indicate dimension and locations of construction and movement joints required to construct the structure in accordance with ACI 301.
 - 1) Location of construction joints is subject to approval of Architect.
 - c. Indicate location of waterstops.
 - d. Indicate form liner layout and form line termination details.
 - e. Indicate proposed schedule and sequence of stripping of forms, shoring removal, and reshoring installation and removal.
 3. Concrete Reinforcing: Comply with ACI SP-066, and include the following:
 - a. Placing drawings that detail fabrication, bending, and placement.

- b. Bar sizes, lengths, materials, grades, bar schedules, stirrup spacing, bent bar diagrams, bar arrangement, location of splices, lengths of lap splices, details of mechanical splice couplers, details of welding splices, tie spacing, hoop spacing, and supports for concrete reinforcement.
 - 4. Cast-In-Place Concrete:
 - a. Construction Joint Layout: Indicate proposed construction joints required to construct structure.
 - 1) Location of construction joints is subject to approval of Architect.
- E. Samples:
 - 1. Waterstops.
 - 2. Vapor retarder.
 - 3. Form Liners: 12 inch square Sample, indicating texture.
- F. Concrete Schedule: For each location of each Class of concrete indicated in "Concrete Mixtures" Article, including the following:
 - 1. Concrete Class designation.
 - 2. Location within Project.
 - 3. Exposure Class designation.
 - 4. Formed Surface Finish designation and final finish.
 - 5. Final finish for floors.
 - 6. Curing process.
 - 7. Floor treatment, if any.

1.4 INFORMATIONAL SUBMITTALS

- A. Qualification Data: For Installer, manufacturer, and testing and inspection agency.
 - 1. Installer: Include copies of applicable ACI certificates.
 - 2. Ready-mixed concrete manufacturer.
- B. Material Certificates: For each of the following, signed by manufacturers:
 - 1. Cementitious materials.
 - 2. Admixtures.
 - 3. Form materials and form-release agents.
 - 4. Steel reinforcement and accessories.
 - 5. Fiber reinforcement.
 - 6. Waterstops.
 - 7. Curing compounds.
 - 8. Floor and slab treatments.
 - 9. Bonding agents.
 - 10. Adhesives.
 - 11. Vapor retarders.
 - 12. Semirigid joint filler.
 - 13. Joint-filler strips.
 - 14. Repair materials.
- C. Welding Certificates.
 - 1. Reinforcement To Be Welded: Welding procedure specification in accordance with AWS D1.4.
- D. Material Test Reports: For the following, from a qualified testing agency:
 - 1. Steel Reinforcement:
 - a. For reinforcement to be welded, mill test analysis for chemical composition and carbon equivalent of the steel in accordance with ASTM A706.
 - 2. Mechanical splice couplers.
 - 3. Portland cement.
 - 4. Fly ash.

5. Slag cement.
6. Silica fume.
7. Aggregates.
8. Admixtures:
 - a. Permeability-Reducing Admixture: Include independent test reports, indicating compliance with specified requirements, including dosage rate used in test.
- E. Research Reports:
 1. For concrete admixtures in accordance with ICC's Acceptance Criteria AC198.
 2. For sheet vapor retarder, showing compliance with ICC AC380.
- F. Preconstruction Test Reports: For each mix design.
- G. Floor surface flatness and levelness measurements indicating compliance with specified tolerances.
- H. Minutes of preinstallation meeting.

1.5 QUALITY ASSURANCE

- A. Installer Qualifications: A qualified installer with a minimum 3 years of experience who employs on Project personnel qualified as ACI-certified Flatwork Technician and Finisher and a supervisor who is an ACI-certified Concrete Flatwork Technician.
- B. Ready-Mixed Concrete Manufacturer Qualifications: A firm with a minimum 10 years of experience in manufacturing ready-mixed concrete products and that complies with ASTM C94 requirements for production facilities and equipment.
 1. Manufacturer member of NRMCA and certified according to NRMCA's "Certification of Ready Mixed Concrete Production Facilities."
- C. Welding Qualifications: Qualify procedures and personnel according to AWS D1.4.
- D. Mockups: Build mockups in compliance with Section 014339 – Mockups to verify selections made under Sample submittals, to demonstrate aesthetic effects, and to set quality standards for materials and execution.
 1. Build mockups approximately 200 sq. ft. for slabs-on-ground and 100 sq. ft. for formed surfaces in locations and of sizes indicated or, if not indicated, build mockups where directed by Architect.
 2. Formed surfaces shall demonstrate typical joints, surface finish, texture, tolerances, and standard of workmanship.
 3. Reinforcing for cast-concrete formed surfaces, to demonstrate tolerances and standard of workmanship.
 4. Cast concrete slab-on-grade and formed-surface panels to demonstrate typical joints, surface finish, texture, tolerances, floor treatments, and standard of workmanship.
 - a. Demonstrate proposed range of aesthetic effects and workmanship.
 - b. In presence of Architect, demonstrate repair of blemished or damaged portion of exposed-face surface.
 5. Obtain Architect's approval of mockups before start of final unit of Work.
 6. Approval of mockups does not constitute approval of deviations from Contract Documents contained in mockups unless Architect specifically approves such deviations in writing.
 7. Retain and maintain mockups during construction in undisturbed condition as a standard for judging completed Work.
 8. Subject to compliance with requirements, approved mockups may become part of completed Work if undisturbed at time of Substantial Completion.

1.6 DELIVERY, STORAGE, AND HANDLING

- A. Comply with ASTM C94 and ACI 301.

- B. Form Liners: Store form liners under cover to protect from sunlight.
- C. Steel Reinforcement: Deliver, store, and handle steel reinforcement to prevent bending and damage, and to avoid damaging coatings on steel reinforcement.
- D. Waterstops: Store waterstops under cover to protect from moisture, sunlight, dirt, oil, and other contaminants.

1.7 FIELD CONDITIONS

- A. Cold-Weather Placement: Comply with ACI 306.1 and as follows:
 - 1. Protect concrete Work from physical damage or reduced strength that could be caused by frost, freezing actions, or low temperatures.
 - 2. When average high and low temperature is expected to fall below 40 deg F for 3 successive days, maintain delivered concrete mixture temperature within temperature range required by ACI 301.
 - 3. Do not use frozen materials or materials containing ice or snow.
 - 4. Do not place concrete on frozen subgrade or on subgrade containing frozen materials.
 - 5. Do not use calcium chloride, salt, or other materials containing antifreeze agents or chemical accelerators unless otherwise specified and approved in mixture designs.
- B. Hot-Weather Placement: Comply with ACI 301 and ACI 305.1 and as follows:
 - 1. Cool ingredients before mixing to maintain concrete temperature below 90 deg F at time of placement. Chilled mixing water or chopped ice may be used to control temperature, provided water equivalent of ice is calculated to total amount of mixing water.
 - a. Contractor's Option: Use of liquid nitrogen to cool concrete.
 - 2. Fog-spray forms, steel reinforcement, and subgrade just before placing concrete. Keep subgrade uniformly moist without standing water, soft spots, or dry areas.

PART 2 - PRODUCTS

2.1 PERFORMANCE CRITERIA

- A. Concrete Formwork: Design, engineer, erect, shore, brace, and maintain formwork, shores, and reshores in accordance with ACI 301, to support vertical, lateral, static, and dynamic loads, and construction loads that might be applied, until structure can support such loads, so that resulting concrete conforms to the required shapes, lines, and dimensions.
 - 1. Design wood panel forms in accordance with APA's "Concrete Forming Design/Construction Guide."
 - 2. Design formwork to limit deflection of form-facing material to 1/240 of center-to-center spacing of supports.

2.2 CONCRETE, GENERAL

- A. ACI Publications: Comply with the following unless modified by requirements in Contract Documents:
 - 1. ACI 301, Specification for Structural Concrete, Sections 1 through 5.
 - 2. ACI 117, "Specifications for Tolerances for Concrete Construction and Materials."

2.3 FORMS

- A. As-Cast Surface Form-Facing Material:
 - 1. Form-facing panels that provide continuous, true, and smooth concrete surfaces, matched, tight fitting, and stiffened to support weight of concrete without deflection detrimental to tolerances and appearance of finished concrete.
 - 2. Furnish in largest practicable sizes to minimize number of joints.

3. Acceptable Materials: As required to comply with Surface Finish designations and as follows:
 - a. Plywood, metal, glass-fiber-reinforced plastic, or other approved panel materials.
 - b. Exterior-grade plywood panels, suitable for concrete forms, complying with DOC PS 1.
 4. Locations: For concrete that will be exposed in finished Work.
- B. Concealed Surface Form-Facing Material: Plywood, lumber, metal, or another approved material.
1. Provide lumber dressed on at least 2 edges and 1 side for tight fit.
 2. Locations: For concrete that will be concealed in finished Work.
- C. Forms for Cylindrical Columns, Pedestals, and Supports: Metal, glass-fiber-reinforced plastic, paper, or fiber tubes that produce surfaces with gradual or abrupt irregularities not exceeding specified formwork surface class.
1. Provide forms with sufficient wall thickness to resist plastic concrete loads without detrimental deformation.
- D. Form Liners:
1. Products: Subject to compliance with requirements, provide one of the following:
 - a. Fast Formliners Co.: Form 18242.
 - b. Approved substitution.
 2. Size: 5-1/2 inch board widths by 1/8 inch deep.
 3. Face Pattern: Wood grain unless indicated otherwise.

2.4 STEEL REINFORCEMENT

- A. Recycled Content of Steel Products: Postconsumer recycled content plus 1/2 of preconsumer recycled content not less than 75 percent.
- B. Reinforcing Bars: ASTM A615, Grade 60, deformed.
- C. Low-Alloy-Steel Reinforcing Bars: ASTM A706, Grade 60, deformed.
- D. Galvanized Reinforcing Bars:
1. Steel Bars: ASTM A615, Grade 60, deformed.
 2. Zinc Coating: ASTM A767, Class I zinc coated after fabrication and bending.
- E. Plain-Steel Wire: ASTM A1064, as drawn.
- F. Deformed-Steel Wire: ASTM A1064, flat sheet.
- G. Steel Bar Mats: ASTM A184, fabricated from ASTM A615, Grade 60, deformed bars, assembled with clips.
- H. Welded-Wire Reinforcement:
1. Plain Steel: ASTM A1064, plain, fabricated from as-drawn steel wire into flat sheets.
 2. Deformed-Steel: ASTM A1064, flat sheet.
 3. Galvanized-Steel: ASTM A1064, plain, fabricated from galvanized-steel wire into flat sheets.

2.5 REINFORCEMENT ACCESSORIES

- A. Joint Dowel Bars: ASTM A615, Grade 60, plain-steel bars, cut true to length with ends square and free of burrs.
- B. Bar Supports: Bolsters, chairs, spacers, and other devices for spacing, supporting, and fastening reinforcing bars, welded-wire reinforcement, and dowels in place.
1. Manufacture bar supports from steel wire, plastic, or precast concrete according to CRSI (DA4) of greater compressive strength than concrete and as follows:
 - a. For concrete surfaces exposed to view, where legs of wire bar supports contact forms, use all-plastic bar supports.

- b. For zinc-coated reinforcement, use galvanized wire or dielectric-polymer-coated wire bar supports.
- C. Galvanizing Repair Coating: Zinc-rich, cold galvanizing compound as specified in Section 055000 – Metal Fabrications.

2.6 CONCRETE MATERIALS

- A. Source Limitations:
 - 1. Obtain concrete mixtures from a single ready-mixed concrete manufacturer for entire Project.
 - 2. Obtain each type or class of cementitious material of same brand from same manufacturer's plant.
 - 3. Obtain aggregate from single source.
 - 4. Obtain each type of admixture from single source from single manufacturer.
- B. Cementitious Materials: Portland Cement; ASTM C150; as follows:
 - 1. Interior Locations: Type I and Type II. Do not use air entrained concrete at interior slabs.
 - 2. Exterior Locations: Type I with specified air entrainment admixture, preferred to Type IA and Type IIA air-entrained concrete. Type IIIA acceptable for cold weather construction.
 - 3. Fly Ash: ASTM C618, Class F or Class C pozzolan, loss on ignition not exceeding 1 percent. Account for lower calcium content of Class F where used.
 - 4. Slag Cement: ASTM C989, Grade 120, ground, granulated blast-furnace slag.
- C. Normal-Weight Aggregates: ASTM C33, Class 3S coarse aggregate or better. Provide aggregates from a single source.
 - 1. Maximum Coarse-Aggregate Size: As follows:
 - a. Slabs and Structural Concrete: Maximum 3/4 inch nominal.
 - 2. Fine Aggregate: Free of materials with deleterious reactivity to alkali in cement.
 - 3. Gradation: Uniformly graded.
- D. Air-Entraining Admixture: ASTM C260; for use at exterior concrete unless indicated otherwise.
 - 1. Refer to structural Drawings for more information.
- E. Chemical Admixtures: Certified by manufacturer to be compatible with other admixtures and that do not contribute water-soluble chloride ions exceeding those permitted in hardened concrete. Do not use calcium chloride or admixtures containing calcium chloride.
 - 1. Water-Reducing Admixture: ASTM C494, Applications as follows:
 - a. Type A: Low range.
 - b. Type F: Mid-range.
 - c. Type A or Type F: High-range.
 - 2. Water-Reducing and Retarding Admixture: ASTM C494, Type D.
 - a. Applications: Use for conditions of high temperatures, low humidity, and other adverse placing conditions, as accepted by Architect.
 - 3. High-Range, Water-Reducing and Retarding Admixture: ASTM C494, Type G.
- F. Moisture Vapor Reduction Admixture (MVRA): Liquid, inorganic admixture free of volatile organic compounds (VOCs) and formulated to close capillary systems formed during curing to reduce moisture vapor emission and transmission, with no adverse effect on concrete properties.
 - 1. Products: Subject to compliance with requirements, provide one of the following:
 - a. AQUAFIN, Inc.: AQUAFIN IC ADMIX - Liquid.
 - b. Barrier One, Inc.: Barrier One Moisture Vapor Reduction Admixture.
 - c. Hycrete, Inc.: Hycrete W1000.
 - d. ISE Logik Industries: MVRA 900.
 - e. Sika Corporation: Sika 1+.
 - f. Specialty Products Group: Vapor Lock 20/21.
 - g. Approved substitutions.
 - 2. Provide admixture in slabs to receive adhesively applied flooring.

- G. Water-Reducing and Retarding Admixture: Crystalline type, permeability-reducing admixture for hydrostatic conditions (PRAH) as defined by ACI 212.3R-10 "Report on Chemical Admixtures for Concrete," Chapter 15; in powdered form for use in ready-mix concrete:
1. Products: Subject to compliance with requirements, provide one of the following:
 - a. AQUAFIN, Inc.: AQUAFIN IC ADMIX- Powder.
 - b. BASF Construction Systems: MasterLife 300D.
 - c. Kryton International Inc.: Krystol Internal Membrane (KIM).
 - d. Penetron International: Penetron
 - e. Sika Corporation: Sika WT-215 P.
 - f. Specialty Products Group: Vapor Lock 20/21
 - g. Xypex Chemical Corporation: ADMIX C-500/C-500 NF
 - h. Approved substitution.
 2. NSF/ANSI Standard 61 certified for use with potable water.
 3. Water Permeability: Maximum zero for water at 200 feet when tested per COE CRD-C 48.
 4. Compressive Strength: Provide independent testing report that shows concrete treated with hydrophobic waterproofing admixture has the capability to increase 7-day and 28-day strength by at least 10 percent when compared to untreated concrete, as measured by ASTM C39.
 5. Water Penetration: Capable of reducing water penetration into concrete by 60 percent or greater in depth of water penetration under pressure after at least 30 days compared to control in concrete EN 12390-8.
 6. Crack Sealing: Capable of self-sealing static cracks with widths up to 0.5 mm.
 7. Permeability: Minimum 40 percent reduction in permeability through concrete treated with hydrophobic waterproofing admixture when tested in accordance with COE CRD C-48 at 200 psi (462 feet water pressure).
- H. In-Situ Carbon Dioxide (CO₂) Mineralization:
1. Technology that injects post-industrial carbon dioxide (CO₂) into concrete during mixing that becomes chemically-converted into a mineral that causes concrete to undergo mix optimization whereby strength enhancement property of CO₂ is utilized to optimize cementitious content
 2. Products: Subject to compliance with requirements, provide one of the following:
 - a. CarbonCure Technologies: CarbonCure Ready Mix Concrete Technology.
 - b. Approved substitution.
- I. Water: Potable and complying with ASTM C94.

2.7 FIBER REINFORCEMENT

- A. Synthetic Monofilament Micro-Fiber: Monofilament polypropylene micro-fibers engineered and designed for use in concrete, complying with ASTM C1116, Type III, 1/2 to 1-1/2 inches long.
1. Products: Subject to compliance with requirements, provide one of the following:
 - a. BASF Construction Systems: MasterFiber M35 or MasterFiber M70.
 - b. Euclid Chemical Co.: PSI Fiberstrand 100 or PSI Fiberstrand 150.
 - c. Fibermesh; a Sika Brand: Fibermesh 150e3.
 - d. FORTA Corporation: FORTA Econo-Mono.
 - e. GCP Applied Technologies Inc.: Sinta M3019.
 - f. Sika Corporation: SikaFiber HP.
 - g. Approved substitution.
 2. Locations: Interior exposed slabs.
 3. Not for use at composite slabs or as replacement for welded-wire fabric.

- B. Synthetic Micro-Fiber: Fibrillated polypropylene micro-fibers engineered and designed for use in concrete, complying with ASTM C1116, Type III, 1/2 to 1-1/2 inches long.
 - 1. Products: Subject to compliance with requirements, provide one of the following:
 - a. BASF Construction Systems: MasterFiber F100.
 - b. Euclid Chemical Co.: PSI Fiberstrand F.
 - c. Fibermesh; a Sika Brand: Fibermesh 300.
 - d. FORTA Corporation: FORTA Econo-Net.
 - e. GCP Applied Technologies Inc.: Sinta F19.
 - f. Sika Corporation: SikaFiber PPF.
 - g. Approved substitution.
 - 2. Locations: Interior slabs schedules for floor coverings, exterior slabs.
 - 3. Not for use at composite slabs or as replacement for welded-wire fabric.

2.8 WATERSTOPS

- A. Self-Expanding Butyl Strip Waterstops: Manufactured rectangular or trapezoidal strip, butyl rubber with sodium bentonite or other hydrophilic polymers, for adhesive bonding to concrete.
 - 1. Products: Subject to compliance with requirements, provide one of the following:
 - a. CETCO – Building Materials Group: Waterstop-RX-101.
 - b. Concrete Sealants Inc.: Conseal CS-231.
 - c. GCP Applied Technologies Inc.: Adcor 500s.
 - d. Henry Company: Hydro-Flex.
 - e. JP Specialties, Inc.: Earth Shield Type 20.
 - f. Sika Corporation: Swellstop.
 - 2. Size: 3/4 x 1 inch.
 - 3. Physical Properties:
 - a. Hydrostatic-Head Resistance: 200 feet; ASTM D5385, modified.
- B. Adhesive: Manufacturer's recommended adhesive for adhering waterstops to substrate.

2.9 VAPOR RETARDERS

- A. Sheet Vapor Retarder: ASTM E1745, Class A. Include manufacturer's recommended adhesive or pressure-sensitive tape.
 - 1. Products: Subject to compliance with requirements, provide one of the following:
 - a. Fortifiber Building Systems Group: Moistop Ultra 15.
 - b. GCP Applied Technologies Inc.: Florprufe 120.
 - c. Insulation Solutions, Inc.: Viper Vaporcheck II 15-mil.
 - d. Raven Engineered Films.: VaporBlock 15.
 - e. Reef Industries, Inc.: Griffolyn 15 mil Green. Stego Industries, LLC: Stego Wrap Vapor Barrier (15-Mil).
 - g. W.R. Meadows, Inc.: Perminator 15 mil.
 - h. Approved substitution.

2.10 LIQUID FLOOR TREATMENTS

- A. Penetrating Liquid Floor Treatment (Type-2): Spray-applied, penetrating, colloidal silica concrete treatment designed to harden and densify concrete surfaces; clear or tinted, odorless, non-toxic, and non-flammable.
 - 1. Products: Subject to compliance with requirements, provide one of the following:
 - a. Solomon Colors, Inc.: Lythic Densifier.
 - b. Spray-Lock Concrete Protection, LLC: SCP 327 – Time of Placement.
 - c. Approved substitution.
 - 2. Provide over slabs on ground that are scheduled to receive adhered flooring materials.

2.11 CURING MATERIALS

- A. Curing Materials, General:
1. Verify products comply with requirements of California Department of Public Health's "Standard Method for the Testing and Evaluation of Volatile Organic Chemical Emissions from Indoor Sources Using Environmental Chambers."
- B. Evaporation Retarder: Waterborne, monomolecular film forming, manufactured for application to fresh concrete to reduce rapid surface moisture evaporation.
1. Products: Subject to compliance with requirements, provide one of the following:
 - a. BASF Construction Systems: MasterKure ER 50. Formerly Confilm
 - b. ChemMasters: Spray-Film.
 - c. Dayton Superior: AquaFilm J74RTU or AuqaFilm Concentrate J74.
 - d. Euclid Chemical Co.: Eucobar.
 - e. Kaufman Products, Inc.: VaporAid.
 - f. Lambert Corporation: LAMBCO Skin.
 - g. Laticrete International, Inc.: E-CON.
 - h. Nox-Crete Products Group: Monofilm.
 - i. Vexcon Chemicals, Inc.: Starseal Assist.
 - j. W.R. Meadows, Inc.: Evapre or Evapre-RTU.
 - k. Approved substitution.
 2. Concentrated versions of specified products are acceptable subject to concentrates being used according to manufacturers' written instructions.
 3. Applications: Apply to concrete surfaces immediately after concrete placement and awaiting finishing in hot, dry, and windy conditions.
- C. Absorptive Cover: AASHTO M 182, Class 2, burlap cloth made from jute or kenaf, weighing approximately 9 oz./sq. yd. when dry.
- D. Moisture-Retaining Cover: Provide one of the following that complies with ASTM C171:
1. Impervious paper consisting of 2 sheets of kraft paper cemented together by a bituminous adhesive with fiber reinforcement.
 2. Polyethylene film, clear or white, minimum nominal thickness of 0.0040 inch.
 3. White-burlap-polyethylene sheet, 40 inches wide, weighing not less than 10 oz./lin. yd.
 4. Color: Comply with the following color restrictions for ambient temperatures:
 - a. Ambient Temperature Below 50 deg F: Black.
 - b. Ambient Temperature between 50 deg F and 85 deg F: Any color.
 - c. Ambient Temperature Above 85 deg F: White.
- E. Curing Paper: Nonstaining, waterproof, 8 foot wide paper, consisting of 2 layers of kraft paper cemented together and reinforced with fiber, and complying with ASTM C171.
1. Products: Subject to compliance with requirements, provide one of the following:
 - a. Fortifiber Building Systems Group: Sisalkraft SK-10.
 - b. Approved substitution.
- F. Water: Potable or complying with ASTM C1602.
- G. Clear, Waterborne, Membrane-Forming, Dissipating Curing Compound: ASTM C309, Type 1, Class A and B, certified by curing compound manufacturer to not interfere with bonding of floor covering.
1. Products: Subject to compliance with requirements, provide one of the following:
 - a. BASF Construction Systems: MasterKure CC 200WB
 - b. ChemMasters: Safe-Cure & Seal 309.
 - c. Dayton Superior: Cure & Seal 309 EF.
 - d. Euclid Chemical Co.: Eucocure VOX.
 - e. Kaufman Products, Inc.: Thinfilm 420.
 - f. Lambert Corporation: Crystal Clear Seal WB.

- g. Laticrete International, Inc.: L&M Dress & Seal WB.
 - h. Nox-Crete Products Group: Cure & Seal 150 E.
 - i. Vexcon Chemicals, Inc.: Certi-Vex Envio Cure 100.
 - j. W.R. Meadows, Inc.: 1100-Clear Series.
 - k. Approved substitution.
- 2. Verify products comply with requirements of California Department of Public Health's "Standard Method for the Testing and Evaluation of Volatile Organic Chemical Emissions from Indoor Sources Using Environmental Chambers."
 - 3. Applications: For exposed interior concrete slab surfaces including parking garages.
- H. Clear, Waterborne, Membrane-Forming Curing and Sealing Compound: ASTM C1315, Type 1, Class A. Product contains acrylic copolymers.
- 1. Products: Subject to compliance with requirements, provide one of the following:
 - a. BASF Construction Systems: MasterKure CC 1315WB.
 - b. ChemMasters: Polyseal WB.
 - c. Dayton Superior: Cure & Seal 1315 EF.
 - d. Euclid Chemical Co.: Super Diamond Clear VOX.
 - e. Kaufman Products, Inc.: Krystal 25 Emulsion.
 - f. Lambert Corporation: Crystal Clear Seal 1315 WB.
 - g. Laticrete International, Inc.: L&M Dress & Seal WB 25.
 - h. Nox-Crete Products Group: Cure & Seal 250 E.
 - i. Vexcon Chemicals, Inc.: Starseal 1315.
 - j. W.R. Meadows, Inc.: Vocomp-30.
 - k. Approved substitution.
 - 2. Verify products comply with requirements of California Department of Public Health's "Standard Method for the Testing and Evaluation of Volatile Organic Chemical Emissions from Indoor Sources Using Environmental Chambers."
 - 3. Applications: For interior and exterior concrete surfaces scheduled to remain exposed.

2.12 RELATED MATERIALS

- A. Reglets: Fabricate reglets of not less than 0.022 inch thick, galvanized-steel sheet. Temporarily fill or cover face opening of reglet to prevent intrusion of concrete or debris.
 - 1. Sizes: As indicated on Drawings.
- B. Dovetail Anchor Slots: Hot-dip galvanized-steel sheet, not less than 0.034 inch thick, with bent tab anchors. Temporarily fill or cover face opening of slots to prevent intrusion of concrete or debris.
- C. Chamfer Strips: Metal, rigid plastic, elastomeric rubber, or dressed wood, 3/4 by 3/4 inch, minimum; nonstaining; in longest practicable lengths.
- D. Form-Release Agent: Commercially-formulated, vegetable-oil based, form-release agent, acceptable to form liner manufacturer, that does not bond with, stain, or adversely affect concrete surfaces and does not impair subsequent treatments of concrete surfaces.
 - 1. Products: Subject to compliance with requirements, provide one of the following:
 - a. BASF Construction Systems: MasterFinish 257P.
 - b. Euclid Chemical Co.: EUCOSLIP VOX.
 - c. Nox-Crete Products Group: Bio-Nox VS.
 - d. Specco Industries: Bio-Form Release.
 - e. Approved substitution.
 - 2. Formulate form-release agent with rust inhibitor for steel form-facing materials.
 - 3. Do not use materials containing diesel oil or petroleum-based compounds.

- E. Form Ties: Factory-fabricated, removable or snap-off, glass-fiber-reinforced plastic or metal form ties designed to resist lateral pressure of fresh concrete on forms, prevent spalling of concrete on removal, and comply with the following:
1. Leaves no corrodible metal closer than 1 inch to the plane of exposed concrete surface.
 2. Leaves holes no larger than 1 inch in diameter in concrete surface when removed.
 3. Where finished concrete is scheduled to receive dampproofing or waterproofing, provide form ties with integral water-barrier plates.
- F. Expansion- and Isolation-Joint-Filler Strips: ASTM D1751, asphalt-saturated cellulosic fiber.
1. Products: Subject to compliance with requirements, provide one of the following:
 - a. Masco Masons Supply Company: Reflex Rubber Joint.
 - b. Right Pointe Company: Right-Joint Fibre Expansion Joint.
 - c. SpecChem: SpecFlex Fiber Expansion Joint.
 - d. W. R. Meadows: FIBRE Expansion Joint.
 - e. Western Louisville Fiberboard: WLF Expansion Joint.
 - f. Approved substitution.
 2. Thickness: 3/4 inch unless indicated otherwise.
 3. Provide for isolation joints at slab and foundation conditions, and where indicated on Drawings.
- G. Semi-Rigid Joint Filler: 2-component, semi rigid, 100 percent solids, epoxy resin or aromatic polyurea.
1. Epoxy Products: Subject to compliance with requirements, provide one of the following:
 - a. Adhesives Technology Corp.: Crackbond JF-311.
 - b. BASF Construction Systems: MasterSeal CR 190.
 - c. Euclid Chemical Co.: EUCO 700.
 - d. MAPEI Corporation: Planibond JF.
 - e. Sika Corporation: Sikadur 51 SL.
 - f. Approved substitution.
 2. Polyurea Products: Subject to compliance with requirements, provide one of the following:
 - a. Adhesives Technology Corp.: Crackbond JF-82 Fast.
 - b. BASF Construction Systems: MasterSeal CR 100.
 - c. Euclid Chemical Co.: Euco Qwikjoint 200.
 - d. MAPEI Corporation: Planiseal RapidJoint 15.
 - e. Sika Corporation: Sika Loadflex-524 EZ.
 - f. Approved substitution.
 3. Colors: Standard Gray unless selected otherwise by Architect from manufacturer's full color range.
 4. Hardness: Shore A Hardness according to ASTM D2240:
 - a. Epoxy: 80.
 - b. Polyurea: 85 to 95.
 5. Tensile Strength: Minimum of 800 psi according to ASTM D412.
 6. Elongation: Minimum 200 percent according to ASTM D412.
 7. Locations: Joints in interior exposed concrete slabs and where indicated.
- H. Keyed Control Joint Devices: Keyed control joint system with tongue and groove profile, removable top plastic cap sealant trough, knockout holes on 6-inch centers for dowels, and ribbed steel spikes with tongue to fit top screed edge.
1. Products: Subject to compliance with requirements, provide one of the following:
 - a. BoMetals, inc.: Pro-Key
 - b. Form-A-Key Products a div. of Cardinal Manufacturing Co.: Key-Loc Joint System.
 - c. Approved substitution.
 2. Materials:
 - a. Keyed Joint Form: ASTM A653, nominal 0.028 inch thick galvanized steel with G90 or thicker coating.
 - b. Stakes: ASTM A569, minimum 0.064 inch nominal thickness, ribbed.
 - c. Removable Cap: Joint device manufacturer's standard 3/8 x 3/8 inch PVC cap.

- I. Bonding Agent: ASTM C1059, Type II, nonredispersible, acrylic emulsion or styrene butadiene.
- J. Epoxy Bonding Adhesive: ASTM C881, 2-component epoxy resin, capable of humid curing and bonding to damp surfaces, of class suitable for application temperature and of grade to suit requirements, and as follows:
 - 1. Types I and II, non-load bearing and Types IV and V, load bearing, for bonding hardened or freshly mixed concrete to hardened concrete.

2.13 REPAIR MATERIALS

- A. Repair Underlayment: Cement-based, polymer-modified, self-leveling product that can be applied in thicknesses from 1/8 inch and that can be feathered at edges to match adjacent floor elevations.
 - 1. Cement Binder: ASTM C150 portland cement or hydraulic or blended hydraulic cement, as defined in ASTM C219.
 - 2. Primer: Product of underlayment manufacturer recommended for substrate, conditions, and application.
 - 3. Aggregate: Well-graded, washed gravel, 1/8 to 1/4 inch or coarse sand, as recommended by underlayment manufacturer.
 - 4. Compressive Strength: Not less than 4,100 psi at 28 days when tested in accordance with ASTM C109.

2.14 CONCRETE MIXTURES, GENERAL

- A. Prepare design mixtures for each type and strength of concrete, proportioned on basis of laboratory trial mixture or field test data, or both, according to ACI 301.
 - 1. Use a qualified independent testing agency for preparing and reporting proposed mixture designs based on laboratory trial mixtures.
- B. Cementitious Materials: Limit percentage, by weight, of cementitious materials other than portland cement in concrete as follows unless indicated otherwise on structural Drawings:
 - 1. Fly Ash or Other Pozzolans: 20 percent by mass.
 - 2. Slag Cement: 20 percent by mass.
 - 3. Silica Fume: 20 percent by mass.
 - 4. Combined Fly Ash or Other Pozzolans, Slag Cement, and Silica Fume: 20 percent by mass, with fly ash or pozzolans not exceeding 25 percent by mass and silica fume not exceeding 10 percent by mass.
 - 5. Combined Fly Ash or Other Pozzolans and Silica Fume: 20 percent by mass with fly ash or pozzolans not exceeding 25 percent by mass and silica fume not exceeding 10 percent by mass.
- C. Admixtures: Use admixtures according to manufacturer's written instructions.
 - 1. Use water-reducing, high-range water-reducing, and plasticizing admixture in concrete, as required, for placement and workability.
 - 2. Use water-reducing and -retarding admixture when required by high temperatures, low humidity, or other adverse placement conditions.
 - 3. Use corrosion-inhibiting admixture in concrete mixtures where indicated.
- D. In-Situ Carbon Dioxide (CO₂) Mineralization: Provide concrete that has undergone in-situ carbon dioxide (CO₂) mineralization in which concrete undergoes mix optimization whereby strength enhancement property of CO₂ is utilized to optimize cementitious content.
 - 1. Ensure that CO₂-mineralized and optimized concrete mix meets specified concrete performance requirements specified in this Section.
 - 2. Architect will review cementitious content and w/c ratios and may require adjustments to ensure compliance with specified performance requirements.

2.15 CONCRETE MIXTURES FOR BUILDING ELEMENTS

- A. Proportion concrete mixes in accordance with requirements indicated in structural Drawing.

2.16 FABRICATING REINFORCEMENT

- A. Fabricate steel reinforcement according to CRSI (DA4).

2.17 CONCRETE MIXING

- A. Ready-Mixed Concrete: Measure, batch, mix, and deliver concrete according to ASTM C94 and ASTM C1116. Furnish batch certificates for each batch discharged and used in Work.
 - 1. When air temperature is between 85 and 90 deg F, reduce mixing and delivery time from 1-1/2 hours to 75 minutes.
 - 2. When air temperature is above 90 deg F, reduce mixing and delivery time to 60 minutes.
 - 3. Monitor concrete in truck and reject if temperature rises to 89 deg F or 5 deg F in 10 minutes, indicating that concrete is setting up prior to discharge.
- B. Project-Site Mixing: Measure, batch, and mix concrete materials and concrete according to ASTM C94. Mix concrete materials in appropriate drum-type batch machine mixer.
 - 1. For concrete batches of 1 cu. yd. or smaller, continue mixing at least 1-1/2 minutes, but not more than 5 minutes, after ingredients are in mixer, before any part of batch is released.
 - 2. For concrete batches larger than 1 cu. yd., increase mixing time by 15 seconds for each additional 1 cu. yd.
 - 3. Provide batch ticket for each batch discharged and used in Work, indicating Project identification name and number, date, mixture type, mixture time, quantity, and amount of water added.
 - 4. Record approximate location of final deposit in structure.

PART 3 - EXECUTION

3.1 INSTALLATION OF FORMWORK

- A. Comply with ACI 301.
- B. Construct formwork so concrete members and structures are of size, shape, alignment, elevation, and position indicated, within tolerance limits of ACI 117, and to comply with Surface Finish designations specified in this Section for as-cast finishes.
- C. Limit concrete surface irregularities, designated by ACI 347 as abrupt or gradual, as follows:
 - 1. Surface Finish-1.0 (SF-1.0): ACI 117 Class D, 1 inch.
 - 2. Surface Finish-2.0 (SF-2.0): ACI 117 Class B, 1/4 inch.
 - 3. Surface Finish-3.0 (SF-3.0): ACI 117 Class A, 1/8 inch.
- D. Construct forms tight enough to prevent loss of concrete mortar and to minimize joints.
 - 1. Exposed Concrete: Symmetrically align joints in forms.
- E. Construct removable forms for easy removal without hammering or prying against concrete surfaces.
 - 1. Provide crush or wrecking plates where stripping may damage cast-concrete surfaces.
 - 2. Provide top forms for inclined surfaces steeper than 1.5 horizontal to 1 vertical.
 - 3. Install keyways, reglets, recesses, and other accessories, for easy removal.
- F. Do not use rust-stained, steel, form-facing material.

- G. Set edge forms, bulkheads, and intermediate screed strips for slabs to achieve required elevations and slopes in finished concrete surfaces.
 - 1. Provide and secure units to support screed strips
 - 2. Use strike-off templates or compacting-type screeds.
- H. Provide temporary openings for cleanouts and inspection ports where interior area of formwork is inaccessible.
 - 1. Close openings with panels tightly fitted to forms and securely braced to prevent loss of concrete mortar.
 - 2. Locate temporary openings in forms at inconspicuous locations.
- I. Chamfer exterior corners and edges of permanently exposed concrete.
- J. At construction joints, overlap forms onto previously placed concrete not less than 12 inches.
- K. Form openings, chases, offsets, sinkages, keyways, reglets, blocking, screeds, and bulkheads required in Work.
 - 1. Determine sizes and locations from trades providing such items.
 - 2. Obtain written approval of Architect prior to forming openings not indicated on Drawings.
- L. Construction and Movement Joints:
 - 1. Construct joints true to line with faces perpendicular to surface plane of concrete.
 - 2. Install so strength and appearance of concrete are not impaired, at locations indicated or as approved by Architect.
 - 3. Place joints perpendicular to main reinforcement.
 - 4. Locate joints for beams, slabs, joists, and girders in middle third of spans.
 - a. Offset joints in girders a minimum distance of twice beam width from a beam-girder intersection.
 - 5. Locate horizontal joints in walls and columns at underside of floors, slabs, beams, and girders and at top of footings or floor slabs.
 - 6. Space vertical joints in walls as indicated on Drawings.
 - a. Locate joints beside piers integral with walls, near corners, and in concealed locations where possible.
- M. Provide temporary ports or openings in formwork where required to facilitate cleaning and inspection.
 - 1. Locate ports and openings in bottom of vertical forms, in inconspicuous location, to allow flushing water to drain.
 - 2. Close temporary ports and openings with tight-fitting panels, flush with inside face of form, and neatly fitted, so joints will not be apparent in exposed concrete surfaces.
- N. Clean forms and adjacent surfaces to receive concrete. Remove chips, wood, sawdust, dirt, and other debris just before placing concrete.
- O. Retighten forms and bracing before placing concrete, as required, to prevent mortar leaks and maintain proper alignment.
- P. Coat contact surfaces of forms with form-release agent, according to manufacturer's written instructions, before placing reinforcement.

3.2 INSTALLATION OF EMBEDDED ITEMS

- A. Place and secure anchorage devices and other embedded items required for adjoining Work that is attached to or supported by cast-in-place concrete.
 - 1. Use setting drawings, templates, diagrams, instructions, and directions furnished with items to be embedded.
 - 2. Install anchor rods, accurately located, to elevations required and complying with tolerances in Section 7.5 of AISC 303.

3. Install reglets to receive waterproofing and to receive through-wall flashings in outer face of concrete frame at exterior walls, where flashing is shown at lintels, shelf angles, and other conditions.
4. Install dovetail anchor slots in concrete structures, as indicated on Drawings.
5. Clean embedded items immediately prior to concrete placement.

3.3 INSTALLATION OF STEEL REINFORCEMENT

- A. Comply with CRSI (DA4) for fabricating, placing, and supporting reinforcement.
 1. Do not cut or puncture vapor retarder. Repair damage and reseal vapor retarder before placing concrete.
- B. Clean reinforcement of loose rust and mill scale, earth, ice, or other bond-reducing materials.
- C. Accurately position, support, and secure reinforcement against displacement.
 1. Maintain minimum concrete cover.
 2. Do not tack weld crossing reinforcing bars.
- D. Preserve clearance between bars of not less than 1 inch, not less than 1 bar diameter, or not less than 1-1/3 times size of large aggregate, whichever is greater.
- E. Provide concrete coverage in accordance with ACI 318.
- F. Set wire ties with ends directed into concrete, not toward exposed concrete surfaces.
- G. Splices: Lap splices as indicated on structural Drawings.
 1. Bars indicated to be continuous, and all vertical bars shall be lapped not less than 36 bar diameters at splices, or 24 inches, whichever is greater.
 2. Stagger splices in accordance with ACI 318.
 3. Mechanical Splice Couplers: Install in accordance with manufacturer's instructions.
 4. Weld reinforcing bars in accordance with AWS D1.4, where indicated on Drawings.
- H. Install welded-wire reinforcement in longest practicable lengths.
 1. Support welded-wire reinforcement in accordance with CRSI (DA4).
 - a. For reinforcement less than W4.0 or D4.0, continuous support spacing shall not exceed 12 inches.
 2. Lap edges and ends of adjoining sheets at least one wire spacing plus 2 inches for plain wire and 8 inches for deformed wire.
 3. Offset laps of adjoining sheet widths to prevent continuous laps in either direction.
 4. Lace overlaps with wire.
- I. Zinc-Coated Reinforcement:
 1. Repair cut and damaged zinc coatings with galvanizing repair coating.
- J. Clean reinforcement of loose rust and mill scale, earth, ice, and other foreign materials that reduce bond to concrete, prior to placing concrete.

3.4 REMOVING AND REUSING FORMS

- A. Formwork for sides of beams, walls, columns, and similar parts of Work that does not support weight of concrete may be removed after cumulatively curing at not less than 50 deg F for 24 hours after placing concrete if concrete is hard enough to not be damaged by form-removal operations and curing and protection operations are maintained.
 1. Leave formwork for beam soffits, joists, slabs, and other structural elements that support weight of concrete in place until concrete has achieved at least 75 percent of its 28-day design compressive strength.
 2. Remove forms only if shores have been arranged to permit removal of forms without loosening or disturbing shores.

- B. Clean and repair surfaces of forms to be reused in Work. Split, frayed, delaminated, or otherwise damaged form-facing material are not acceptable for exposed surfaces. Apply new form-release agent.
- C. When forms are reused, clean surfaces, remove fins and laitance, and tighten to close joints. Align and secure joints to avoid offsets. Do not use patched forms for exposed concrete surfaces unless approved by Architect.

3.5 SHORING AND RESHORING

- A. Comply with ACI 301 and ACI 318 for design, installation, and removal of shoring and reshoring.
 - 1. Do not remove shoring or reshoring until measurement of slab tolerances is complete.
- B. Plan sequence of removal of shores and reshore to avoid damage to concrete. Locate and provide adequate reshoring to support construction without excessive stress or deflection.

3.6 INSTALLATION OF VAPOR-RETARDER

- A. Sheet Vapor Retarders: Place, protect, and repair sheet vapor retarder according to ASTM E1643 and manufacturer's written instructions.
 - 1. Lap joints 6 inches and seal with manufacturer's recommended tape.

3.7 JOINTS

- A. Form construction, isolation, and contraction joints and tool edges true to line, with faces perpendicular to surface plane of concrete. Construct transverse joints at right angles to centerline unless otherwise indicated.
- B. Construction Joints: Coordinate with floor slab pattern and concrete placement sequence.
 - 1. Install so strength and appearance of concrete are not impaired, at locations indicated or as approved by Architect.
 - 2. Place joints perpendicular to main reinforcement.
 - a. Continue reinforcement across construction joints unless otherwise indicated.
 - b. Do not continue reinforcement through sides of strip placements of floors and slabs.
 - 3. Form keyed joints as indicated. Embed keys at least 1-1/2 inches into concrete.
 - 4. Locate joints for beams, slabs, joists, and girders in middle third of spans. Offset joints in girders a minimum distance of twice beam width from a beam-girder intersection.
 - 5. Locate horizontal joints in walls and columns at underside of floors, slabs, beams, and girders and at top of footings or floor slabs.
 - 6. Space vertical joints in walls as indicated on Drawings. Locate vertical joints beside piers integral with walls, near corners, and in concealed locations where possible.
 - 7. Use a bonding agent at locations where fresh concrete is placed against non-structural hardened or partially hardened concrete surfaces.
 - 8. Use epoxy-bonding adhesive at locations where fresh concrete is placed against structural or load-bearing hardened or partially hardened concrete surfaces, and where curing in humid conditions exist.
- C. Control Joints in Slabs-on-Ground: Form weakened-plane control joints, sectioning concrete into areas as indicated on Drawings and approved Shop Drawings. Construct control joints for a depth equal to at least 1/4 of concrete thickness, but not less than 1 inch, as follows:
 - 1. Early-Entry Sawed Joints: Form control joints on both interior and exterior slabs using early-entry dry-cut saws and methods in accordance with ACI 302.1R, Chapter 8. Acceptable alternatives include the following:
 - a. Sawed Joints: Form control joints with power saws equipped with shatterproof abrasive or diamond-rimmed blades. Cut 1/8 inch wide joints into concrete when cutting action does not tear, abrade, or otherwise damage surface and before concrete develops random cracks.

- b. Grooved Joints: Form control joints after initial floating by grooving and finishing each edge of joint to a radius of 1/8 inch. Repeat grooving of control joints after applying surface finishes. Eliminate groover tool marks on concrete surfaces.
 - 2. Verify control joint forming methods and locations with Architect before proceeding.
 - D. Isolation Joints in Slabs-on-Ground: After removing formwork, install joint-filler strips at slab junctions with vertical surfaces, such as column pedestals, foundation walls, **[grade beams,]** and other locations, as indicated.
 - 1. Extend joint-filler strips full width and depth of joint, terminating flush with finished concrete surface unless otherwise indicated.
 - 2. Terminate full-width joint-filler strips not less than 1/2 inch or more than 1 inch below finished concrete surface where joint sealants, specified in Section 079200 – Joint Sealants, are indicated.
 - 3. Install joint-filler strips in lengths as long as practicable. Where more than 1 length is required, lace or clip sections together.
 - E. Doweled Joints:
 - 1. Install dowel bars and support assemblies at joints where indicated.
 - 2. Lubricate or asphalt coat 1/2 of dowel length to prevent concrete bonding to 1 side of joint.
- 3.8 INSTALLATION OF WATERSTOPS
- A. Self-Expanding Strip Waterstops: Install in construction joints and at other locations indicated, according to manufacturer's written instructions, adhesive bonding, mechanically fastening, and firmly pressing into place. Install in longest lengths practicable.
 - 1. Install in longest lengths practicable.
 - 2. Locate waterstops in center of joint unless otherwise indicated on Drawings.
 - 3. Protect exposed waterstops during progress of Work.
- 3.9 CONCRETE PLACEMENT
- A. Notify Architect and testing and inspection agencies 24 hours prior to commencement of concrete placement.
 - B. Before placing concrete, verify that installation of formwork, reinforcement, and embedded items is complete and that required inspections are completed.
 - 1. Immediately prior to concrete placement, inspect vapor retarder for damage and deficient installation, and repair defective areas.
 - 2. Provide continuous inspection of vapor retarder during concrete placement and make necessary repairs to damaged areas as Work progresses.
 - C. Do not add water to concrete during delivery, at Project site, or during placement unless approved by Architect in writing, but not to exceed the amount indicated on the concrete delivery ticket.
 - 1. Do not add water to concrete after adding high-range water-reducing admixtures to mixture.
 - D. Before test sampling and placing concrete, water may be added at Project site, subject to limitations of ACI 301, but not to exceed the amount indicated on the concrete delivery ticket.
 - 1. Do not add water to concrete after adding high-range water-reducing admixtures to mixture.
 - E. Deposit concrete continuously in 1 layer or in horizontal layers of such thickness that no new concrete is placed on concrete that has hardened enough to cause seams or planes of weakness.
 - 1. If a section cannot be placed continuously, provide construction joints as indicated.
 - 2. Deposit concrete to avoid segregation.
 - 3. Deposit concrete in horizontal layers of depth not to exceed formwork design pressures and in a manner to avoid inclined construction joints.

4. Consolidate placed concrete with mechanical vibrating equipment according to ACI 301.
 - a. Do not use vibrators to transport concrete inside forms.
 - b. Insert and withdraw vibrators vertically at uniformly spaced locations to rapidly penetrate placed layer and at least 6 inches into preceding layer.
 - c. Do not insert vibrators into lower layers of concrete that have begun to lose plasticity.
 - d. At each insertion, limit duration of vibration to time necessary to consolidate concrete, and complete embedment of reinforcement and other embedded items without causing mixture constituents to segregate.

- F. Deposit and consolidate concrete for floors and slabs in a continuous operation, within limits of construction joints, until placement of a panel or section is complete.
 1. Do not place concrete floors and slabs in a checkerboard sequence.
 2. Consolidate concrete during placement operations, so concrete is thoroughly worked around reinforcement and other embedded items and into corners.
 3. Maintain reinforcement in position on chairs during concrete placement.
 4. Screed slab surfaces with a straightedge and strike off to correct elevations.
 5. Level concrete, cut high areas, and fill low areas.
 6. Slope surfaces uniformly to drains where required.
 7. Begin initial floating using bull floats or darbies to form a uniform and open-textured surface plane, before excess bleedwater appears on the surface.
 8. Do not further disturb slab surfaces before starting finishing operations.

3.10 FINISHING FORMED SURFACES

- A. As-Cast Surface Finishes:
 1. ACI 301 Surface Finish SF-1.0: As-cast concrete texture imparted by form-facing material.
 - a. Patch voids larger than 1-1/2 inches wide or 1/2 inch deep.
 - b. Remove projections larger than 1 inch.
 - c. Tie holes do not require patching.
 - d. Surface Tolerance: ACI 117 Class D.
 - e. Locations: Concrete surfaces not exposed to public view.
 2. ACI 301 Surface Finish SF-2.0: As-cast concrete texture imparted by form-facing material, arranged in an orderly and symmetrical manner with a minimum of seams.
 - a. Patch voids larger than 3/4 inch wide or 1/2 inch deep.
 - b. Remove projections larger than 1/4 inch.
 - c. Patch tie holes.
 - d. Surface Tolerance: ACI 117 Class B.
 - e. Locations: Concrete surfaces exposed to public view, to receive a rubbed finish, or to be covered with a coating or covering material applied directly to concrete.

- B. Rubbed Finish: Apply the following to as-cast concrete where indicated on Drawings
 1. Smooth-Rubbed Finish:
 - a. Perform not later than 1 day after form removal.
 - b. Moisten concrete surfaces and rub with carborundum brick or another abrasive until producing a uniform color and texture. Do not apply cement grout other than that created by rubbing process.
 - c. If sufficient cement paste cannot be drawn from concrete by rubbing process, use a grout made from same cementitious materials used in the in-place concrete.
 - d. Maintain required patterns or variances as shown on Drawings or to match mockups.

- C. Related Unformed Surfaces:
 1. At tops of walls, horizontal offsets, and similar unformed surfaces adjacent to formed surfaces, strike off smooth and finish with a texture matching adjacent formed surfaces.
 2. Continue final surface treatment of formed surfaces uniformly across adjacent unformed surfaces unless otherwise indicated.

3.11 FINISHING FLOORS AND SLABS

- A. Comply with ACI 302.1R recommendations for screeding, restraighening, and finishing operations for concrete surfaces. Do not wet concrete surfaces.
- B. Scratch Finish:
 - 1. While still plastic, texture concrete surface that has been screeded and bull-floated or darbied.
 - 2. Use stiff brushes, brooms, or rakes to produce a profile amplitude of 1/4 inch in one direction.
 - 3. Locations: Surfaces to receive concrete floor toppings.
- C. Float Finish:
 - 1. When bleedwater sheen has disappeared and concrete surface has stiffened sufficiently to permit operation of specific float apparatus, consolidate concrete surface with power-driven floats or by hand floating if area is small or inaccessible to power-driven floats.
 - 2. Repeat float passes and restraighening until surface is left with a uniform, smooth, granular texture and complies with ACI 117 tolerances for conventional concrete.
 - 3. Locations: Surfaces to receive trowel finish.
- D. Trowel Finish:
 - 1. After applying float finish, apply first troweling and consolidate concrete by hand or power-driven trowel.
 - 2. Continue troweling passes and restraighen until surface is free of trowel marks and uniform in texture and appearance.
 - 3. Grind smooth surface defects that would telegraph through applied coatings or floor coverings.
 - 4. Do not add water to concrete surface.
 - 5. Do not apply hard-troweled finish to concrete that has a total air content greater than 3 percent.
 - 6. Locations: Surfaces exposed to view or to be covered with resilient flooring, carpet, ceramic tile set over a cleavage membrane, and liquid floor treatments.
- E. Trowel and Fine-Broom Finish:
 - 1. While concrete is still plastic, slightly scarify surface with a fine broom.
 - 2. Coordinate required final finish with Architect before application.
 - 3. Comply with flatness and levelness tolerances for trowel-finished floor surfaces.
 - 4. Locations: Surfaces indicated on Drawings and where ceramic tile is to be installed by either thickset or thinset method.
- F. Broom Finish: Apply a broom finish to exterior concrete platforms, steps, ramps, and elsewhere as indicated.
 - 1. Immediately after float finishing, slightly roughen trafficked surface by brooming with fiber-bristle broom perpendicular to main traffic route.
 - 2. Coordinate required final finish with Architect before application.

3.12 INSTALLATION OF MISCELLANEOUS CONCRETE ITEMS

- A. Filling In:
 - 1. Fill in holes and openings left in concrete structures after Work of other trades is in place unless otherwise indicated.
 - 2. Mix, place, and cure concrete, as specified, to blend with in-place construction.
 - 3. Provide other miscellaneous concrete filling indicated or required to complete Work.
- B. Interior Curbs:
 - 1. Provide monolithic finish to interior curbs by stripping forms while concrete is still green and by steel-troweling surfaces to a hard, dense finish with corners, intersections, and terminations slightly rounded.

C. Equipment Bases and Foundations:

1. Coordinate sizes and locations of concrete bases with actual equipment provided.
2. Construct concrete bases as indicated on Drawings, and extend base not less than 6 inches in each direction beyond maximum dimensions of supported equipment unless otherwise indicated or unless required for seismic anchor support.
3. Minimum Compressive Strength: 4,000 psi at 28 days.
4. Install dowel rods to connect concrete base to concrete floor. Unless otherwise indicated, install dowel rods on 18 inch centers around full perimeter of concrete base.
5. For supported equipment, install anchor bolts that extend through concrete base and anchor into structural concrete substrate.
6. Prior to pouring concrete, place and secure anchorage devices.
 - a. Use setting drawings, templates, diagrams, instructions, and directions furnished with items to be embedded.
 - b. Cast anchor-bolt insert into bases.
 - c. Install anchor bolts to elevations required for proper attachment to supported equipment.

3.13 CONCRETE CURING

- A. Protect freshly placed concrete from premature drying and excessive cold or hot temperatures.
1. Comply with ACI 301 and ACI 306.1 for cold-weather protection.
 2. Comply with ACI 301 and ACI 305.1 for hot-weather protection during curing.
 3. Maintain moisture loss no more than 0.2 lb/sq. ft. x h before and during finishing operations.
- B. Curing Formed Surfaces: Comply with ACI 308.1 as follows:
1. Cure formed concrete surfaces, including underside of beams, supported slabs, and other similar surfaces.
 2. If forms remain during curing period, moist cure after loosening forms.
 3. If removing forms before end of curing period, continue curing for remainder of curing period, as follows:
 - a. Continuous Fogging: Maintain standing water on concrete surface until final setting of concrete.
 - b. Continuous Sprinkling: Maintain concrete surface continuously wet.
 - c. Absorptive Cover: Pre-dampen absorptive material before application; apply additional water to absorptive material to maintain concrete surface continuously wet.
 - d. Water-Retention Sheeting Materials: Cover exposed concrete surfaces with sheeting material, taping, or lapping seams.
 - e. Membrane-Forming Curing Compound: Apply uniformly in continuous operation by power spray or roller in accordance with manufacturer's written instructions.
 - 1) Recoat areas subject to heavy rainfall within 3 hours after initial application.
 - 2) Maintain continuity of coating and repair damage during curing period.
- C. Curing Interior Unformed Surfaces: Comply with ACI 308.1:
1. Begin curing immediately after finishing concrete by one or a combination of the following methods:
 - a. Absorptive Cover: As soon as concrete has sufficient set to permit application without marring concrete surface, install prewetted absorptive cover over entire area of floor.
 - 1) Lap edges and ends of absorptive cover not less than 12 inches.
 - 2) Maintain absorptive cover water saturated, and in place, for duration of curing period, but not less than 7 days.

- b. Moisture-Retaining-Cover Curing: Cover concrete surfaces with moisture-retaining cover for curing concrete, placed in widest practicable width, with sides and ends lapped at least 12 inches, and sealed by waterproof tape or adhesive.
 - 1) Immediately repair holes or tears during curing period, using cover material and waterproof tape.
 - 2) Cure for not less than 7 days.
 - c. Ponding or Continuous Sprinkling of Water:
 - 1) Maintain concrete surfaces continuously wet for not less than 7 days utilizing water or continuous water-fog spray.
 - d. Applications:
 - 1) Surfaces to receive floor coverings specified in other Sections.
 - 2) Surfaces to receive penetrating liquid floor treatments.
2. Floors to Receive Curing Compound:
- a. Apply uniformly in continuous operation by power spray or roller according to manufacturer's written instructions.
 - b. Recoat areas subjected to heavy rainfall within 3 hours after initial application.
 - c. Maintain continuity of coating and repair damage during curing period.
 - d. Removal: After curing period has elapsed, remove curing compound without damaging concrete surfaces by method recommended by curing compound manufacturer unless manufacturer certifies curing compound does not interfere with bonding of floor covering used on Project.
 - e. Applications:
 - 1) Type 1: Apply to surfaces scheduled to receive adhesive-applied floor coverings.
 - 2) Type 2: Apply to surfaces scheduled to be left exposed.
3. Floors to Receive Curing and Sealing Compound:
- a. Apply uniformly to floors and slabs indicated in a continuous operation by power spray or roller according to manufacturer's written instructions.
 - b. Recoat areas subjected to heavy rainfall within 3 hours after initial application.
 - c. Repeat process 24 hours later and apply a second coat. Maintain continuity of coating and repair damage during curing period.
 - d. Applications: Apply to exterior slabs only. Do not use on interior slabs unless indicated otherwise.

3.14 TOLERANCES

- A. Finish surfaces to the following tolerances, in accordance with ASTM E1155, for a randomly trafficked floor surface:
- 1. Slabs on Ground, Floor Areas Less Than 10,000 Sq. Ft.:
 - a. Finish and measure surface so gap at any point between concrete surface and an unlevelled, freestanding, 10 ft. long straightedge resting on 2 high spots and placed anywhere on surface does not exceed 1/4 inch, or 1/16 inch in 2 feet where gauged porcelain tile is scheduled.
 - 2. Slabs on Ground, Floor Areas Greater Than 10,000 Sq. Ft.:
 - a. Slabs Scheduled to Receive Carpeting: Specified overall values of flatness, F_F 25; and of levelness, F_L 20; with minimum local values of flatness, F_F 17; and of levelness, F_L 15.
 - b. Slabs Scheduled to Receive Thin Floor Coverings: Specified overall values of flatness, F_F 35; and of levelness, F_L 25; with minimum local values of flatness, F_F 24; and of levelness, F_L 17.
 - 3. Suspended Slabs, Floor Areas Less Than 10,000 Sq. Ft.:
 - a. Finish and measure surface so gap at any point between concrete surface and an unlevelled, freestanding, 10 ft long straightedge resting on 2 high spots and placed anywhere on surface does not exceed 1/4 inch, or 1/16 inch in 2 feet where gauged porcelain tile is scheduled.

4. Suspended Slabs, Floor Areas Greater Than 10,000 Sq. Ft.:
 - a. Slabs Scheduled to Receive Carpeting: Specified overall values of flatness, F_F 25; and of levelness, F_L 20; with minimum local values of flatness, F_F 17; and of levelness, F_L 15.
 - b. Slabs Scheduled to Receive Thin Floor Coverings: Specified overall values of flatness, F_F 35; and of levelness, F_L 25; with minimum local values of flatness, F_F 24; and of levelness, F_L 17.

3.15 APPLICATION OF LIQUID FLOOR TREATMENTS

- A. Penetrating Liquid Floor Treatment: Prepare, apply, and finish penetrating liquid floor treatment according to manufacturer's written instructions.
 1. Remove curing compounds, sealers, oil, dirt, laitance, and other contaminants and complete surface repairs using a fully automatic floor scrubber with 100 grit sanding screens.
 2. Do not apply to concrete that is less than 28 days old.
 3. Apply liquid until surface is saturated, scrubbing into surface until a gel forms; rewet; and repeat brooming or scrubbing.
 4. Rinse with water; remove excess material until surface is dry.
 5. Apply a second coat in a similar manner if surface is rough or porous.

3.16 JOINT FILLING

- A. Prepare, clean, and install joint filler according to manufacturer's written instructions.
 1. Defer joint filling until concrete has aged as follows:
 - a. Semi-Rigid Joint Fillers: Minimum 1 month.
 - b. Joint Sealants Specified in Section 079200: Minimum 6 months.
 2. Do not fill joints until construction traffic has permanently ceased.
- B. Remove dirt, debris, saw cuttings, curing compounds, and sealers from joints; leave contact faces of joints clean and dry.
- C. Install semi-rigid joint filler full depth in saw-cut joints and at least 2 inches deep in formed joints.
- D. Overfill joint and trim joint filler flush with top of joint after hardening.

3.17 CONCRETE SURFACE REPAIRS

- A. Defective Concrete:
 1. Repair and patch defective areas when approved by Architect.
 2. Remove and replace concrete that cannot be repaired and patched to Architect's approval.
- B. Patching Mortar:
 1. Mix dry-pack patching mortar, consisting of 1 part portland cement to 2-1/2 parts fine aggregate passing a No. 16 sieve, using only enough water for handling and placing.
- C. Repairing Formed Surfaces: Surface defects include color and texture irregularities, cracks, spalls, air bubbles, honeycombs, rock pockets, fins and other projections on surface, and stains and other discolorations that cannot be removed by cleaning.
 1. Immediately after form removal, cut out honeycombs, rock pockets, and voids more than 1/2 inch in any dimension to solid concrete.
 - a. Limit cut depth to 3/4 inch.
 - b. Make edges of cuts perpendicular to concrete surface.
 - c. Clean, dampen with water, and brush-coat holes and voids with bonding agent.
 - d. Fill and compact with patching mortar before bonding agent has dried.
 - e. Fill form-tie voids with patching mortar or cone plugs secured in place with bonding agent.

2. Repair defects on surfaces exposed to view by blending white portland cement and standard portland cement so that, when dry, patching mortar matches surrounding color.
 - a. Patch a test area at inconspicuous locations to verify mixture and color match before proceeding with patching.
 - b. Compact mortar in place and strike off slightly higher than surrounding surface.
 3. Repair defects on concealed formed surfaces that affect concrete's durability and structural performance as determined by Architect.
- D. Repairing Unformed Surfaces:
1. Test unformed surfaces, such as floors and slabs, for finish and verify surface tolerances specified for each surface.
 - a. Correct low and high areas.
 - b. Test surfaces sloped to drain for trueness of slope and smoothness; use a sloped template.
 2. Repair finished surfaces containing defects. including spalls, popouts, honeycombs, rock pockets, crazing and cracks in excess of 0.01 inch wide or that penetrate to reinforcement or completely through unreinforced sections regardless of width, and other objectionable conditions.
 3. After concrete has cured at least 14 days, correct high areas by grinding.
 4. Correct localized low areas during or immediately after completing surface finishing operations by cutting out low areas and replacing with patching mortar.
 - a. Finish repaired areas to blend into adjacent concrete.
 5. Correct other low areas scheduled to receive floor coverings with a repair underlayment.
 - a. Prepare, mix, and apply repair underlayment and primer according to manufacturer's written instructions to produce a smooth, uniform, plane, and level surface.
 - b. Feather edges to match adjacent floor elevations.
 6. Correct other low areas scheduled to remain exposed with a repair topping.
 - a. Cut out low areas to ensure a minimum repair topping depth of 1/4 inch to match adjacent floor elevations.
 - b. Prepare, mix, and apply repair topping and primer according to manufacturer's written instructions to produce a smooth, uniform, plane, and level surface.
 7. Repair defective areas, except random cracks and single holes 1 inch or less in diameter, by cutting out and replacing with fresh concrete.
 - a. Remove defective areas with clean, square cuts and expose steel reinforcement with at least a 3/4 inch clearance all around.
 - b. Dampen concrete surfaces in contact with patching concrete and apply bonding agent.
 - c. Mix patching concrete of same materials and mixture as original concrete, except without coarse aggregate.
 - d. Place, compact, and finish to blend with adjacent finished concrete.
 - e. Cure in same manner as adjacent concrete.
 8. Repair random cracks and single holes 1 inch or less in diameter with patching mortar.
 - a. Groove top of cracks and cut out holes to sound concrete and clean off dust, dirt, and loose particles.
 - b. Dampen cleaned concrete surfaces and apply bonding agent.
 - c. Place patching mortar before bonding agent has dried.
 - d. Compact patching mortar and finish to match adjacent concrete.
 - e. Keep patched area continuously moist for at least 72 hours.
- E. Perform structural repairs of concrete, subject to Architect's approval, using epoxy adhesive and patching mortar.
- F. Repair materials and installation not specified above may be used, subject to Architect's written approval.

3.18 FIELD QUALITY CONTROL

- A. Special Inspections: Owner will engage a special inspector and qualified testing and inspecting agency to perform field tests and inspections and prepare test reports.
- B. Testing Agency: Owner will engage a qualified testing and inspecting agency to perform tests and inspections and to submit reports.
 - 1. Testing agency shall be responsible for providing curing container for composite samples on Site and verifying that field-cured composite samples are cured in accordance with ASTM C31.
 - 2. Testing agency shall immediately report to Architect, Contractor, and concrete manufacturer any failure of Work to comply with Contract Documents.
 - 3. Testing agency shall report results of tests and inspections, in writing, to Owner, Architect, Contractor, and concrete manufacturer within 48 hours of inspections and tests.
 - a. Test reports shall include reporting requirements of ASTM C31, ASTM C39, and ACI 301, including the following as applicable to each test and inspection:
 - 1) Project name.
 - 2) Name of testing agency.
 - 3) Names and certification numbers of field and laboratory technicians performing inspections and testing.
 - 4) Name of concrete manufacturer.
 - 5) Date and time of inspection, sampling, and field testing.
 - 6) Date and time of concrete placement.
 - 7) Location in Work of concrete represented by samples.
 - 8) Date and time sample was obtained.
 - 9) Truck and batch ticket numbers.
 - 10) Design compressive strength at 28 days.
 - 11) Concrete mixture designation, proportions, and materials.
 - 12) Field test results.
 - 13) Information on storage and curing of samples before testing, including curing method and maximum and minimum temperatures during initial curing period.
 - 14) Type of fracture and compressive break strengths at seven days and 28 days.
- C. Batch Tickets: For each load delivered, submit 3 copies of batch delivery ticket to testing agency, indicating quantity, mix identification, admixtures, design strength, aggregate size, design air content, design slump at time of batching, and amount of water that can be added at Project site.
- D. Inspections:
 - 1. Inspect formwork for shape, location, and dimensions of concrete member being formed.
 - 2. Steel-reinforcement placement.
 - 3. Steel-reinforcement mechanical splice couplers.
 - 4. Steel-reinforcement welding.
 - 5. Headed bolts and studs.
 - 6. Verification of use of required design mixture.
 - 7. Concrete placement, including conveying and depositing.
 - 8. Curing procedures and maintenance of curing temperature.
 - 9. Verification of concrete strength before removal of shores and forms from beams and slabs.
 - 10. Batch Plant Inspections: On a random basis, as determined by Architect.
- E. Concrete Tests: Perform testing of composite samples of fresh concrete obtained according to ASTM C172 according to the following requirements:
 - 1. Testing Frequency: Obtain at least 1 composite sample for each 150 cu. yd. or fraction thereof of each concrete mixture placed each day.
 - a. When frequency of testing provides fewer than 5 compressive-strength tests for each concrete mixture, testing shall be conducted from at least 5 randomly selected batches or from each batch if fewer than 5 are used.

2. Slump: ASTM C143:
 - a. 1 test at point of placement for each composite sample, but not less than 1 test for each day's pour of each concrete mixture.
 - b. Perform additional tests when concrete consistency appears to change.
 3. Slump Flow: ASTM C1611:
 - a. 1 test at point of placement for each composite sample, but not less than 1 test for each day's pour of each concrete mixture.
 - b. Perform additional tests when concrete consistency appears to change.
 4. Air Content: ASTM C231, pressure method, for normal-weight concrete:
 - a. 1 test for each composite sample, but not less than 1 test for each day's pour of each concrete mixture.
 5. Concrete Temperature: ASTM C1064:
 - a. 1 test hourly when air temperature is 40 deg F and below or 80 deg F and above, and 1 test for each composite sample.
 6. Compression Test Specimens: ASTM C31.
 - a. Cast and laboratory cure 2 sets of 3 standard cylinder specimens for each composite sample.
 - b. Cast, initial cure, and field cure 2 sets of 3 standard cylinder specimens for each composite sample.
 7. Compressive-Strength Tests: ASTM C39:
 - a. Test 1 set of 2 laboratory-cured specimens at 7 days and 1 set of 2 specimens at 28 days.
 - b. Test 1 set of 3 field-cured specimens at 7 days and 1 set of 2 specimens at 28 days.
 - c. A compressive-strength test shall be the average compressive strength from a set of 3 specimens obtained from same composite sample and tested at age indicated.
 8. When strength of field-cured cylinders is less than 85 percent of companion laboratory-cured cylinders, evaluate operations and provide corrective procedures for protecting and curing in-place concrete.
 9. Strength of each concrete mixture will be satisfactory if every average of any 3 consecutive compressive-strength tests equals or exceeds specified compressive strength, and no compressive-strength test value falls below specified compressive strength by more than 500 psi if specified compressive strength is 5,000 psi, or no compressive strength test value is less than 10 percent of specified compressive strength if specified compressive strength is greater than 5,000 psi.
 10. Nondestructive Testing: Impact hammer, sonoscope, or other nondestructive device may be permitted by Architect but will not be used as sole basis for approval or rejection of concrete.
 11. Additional Tests:
 - a. Testing and inspecting agency shall make additional tests of concrete when test results indicate that slump, air entrainment, compressive strengths, or other requirements have not been met, as directed by Architect.
 - b. Testing and inspecting agency may conduct tests to determine adequacy of concrete by cored cylinders complying with ASTM C42 or by other methods as directed by Architect.
 - 1) Acceptance criteria for concrete strength shall be in accordance with ACI 301 section 1.6.6.3.
 12. Additional testing and inspecting, at Contractor's expense, will be performed to determine compliance of replaced or additional Work with specified requirements.
 13. Correct deficiencies in Work that test reports and inspections indicate do not comply with Contract Documents.
- F. Measure floor and slab flatness and levelness according to ASTM E1155 within 48 hours of finishing and promptly report test results to Architect.

3.19 PROTECTION

- A. Protect concrete surfaces as follows:
 - 1. Petroleum stains.
 - 2. Diaper hydraulic equipment used over concrete surfaces.
 - 3. Liquid floor treatment from damage and wear during remainder of construction period. Use protective methods and materials, including temporary covering, recommended in writing by liquid floor treatments installer.
 - 4. Concrete surfaces scheduled to receive surface hardener using Floor Slab Protective Covering.

- B. Prohibit the following:
 - 1. Vehicles from interior concrete slabs.
 - 2. Use of pipe-cutting machinery over concrete surfaces.
 - 3. Placement of steel items on concrete surfaces.
 - 4. Use of acids or acidic detergents over concrete surfaces.

END OF SECTION 033000

SECTION 034500
PRECAST ARCHITECTURAL CONCRETE

PART 1 - GENERAL

1.1 SUMMARY

- A. Section Includes:
 - 1. Architectural precast concrete stair treads, landings, and splash block units.

1.2 ADMINISTRATIVE REQUIREMENTS

- A. Coordination:
 - 1. Furnish loose connection hardware and anchorage items to be embedded in or attached to other construction without delaying Work. Provide locations, setting diagrams, templates, instructions, and directions, as required, for installation.
- B. Preinstallation Meeting: Conduct meeting at Project site.

1.3 ACTION SUBMITTALS

- A. Product Data: For each type of product.
- B. Sustainable Design Submittals:
 - 1. Product Data: For recycled content, indicating postconsumer and preconsumer recycled content and cost.
- C. Design Mixtures: For each precast concrete mixture. Include compressive strength and water-absorption tests.
- D. Shop Drawings:
 - 1. Detail fabrication and installation of architectural precast concrete units.
 - 2. Indicate locations, plans, elevations, dimensions, shapes, and cross sections of each unit.
 - 3. Indicate joints, reveals, drips, chamfers, and extent and location of each surface finish.
 - 4. Indicate locations, tolerances, and details of anchorage devices to be embedded in or attached to structure or other construction.
 - 5. Indicate location of each architectural precast concrete unit by same identification mark placed on panel.
 - 6. Indicate relationship of architectural precast concrete units to adjacent materials.
- E. Samples for Verification: Of each type of architectural precast concrete units with type of finish indicated on exposed surfaces.
 - 1. Stair Treads and Landings: 12 inch long section of full tread depth, indicating proposed finishes, end condition, abrasive nosings, and anchorage assembly.
 - 2. Splash blocks.

1.4 INFORMATIONAL SUBMITTALS

- A. Qualification Data: For Installer and fabricator.
- B. Material Certificates: For the following items:
 - 1. Cementitious materials, admixtures, and reinforcing materials.
- C. Material Test Reports: For aggregates.
- D. Preconstruction test reports.

1.5 QUALITY ASSURANCE

- A. Installer Qualifications: A precast concrete erector with a minimum of 5 years of experience, qualified and designated by PCI's Certificate of Compliance to erect Category A (Architectural Systems) for non-load-bearing members.
- B. Fabricator Qualifications: A firm with a minimum of 5 years of experience that assumes full responsibility for engineering architectural precast concrete units to comply with Performance Criteria Article. This responsibility includes preparation of Shop Drawings and comprehensive engineering analysis by a qualified professional engineer.
 - 1. Designated as a PCI-certified plant for Group A, Category A1 - Architectural Precast Products at time of bidding or designated as an APA-certified plant for production of precast architectural concrete products.
- C. Quality-Control Standard: For manufacturing procedures and testing requirements, quality-control recommendations, and dimensional tolerances for types of units required, comply with PCI MNL 117, "Manual for Quality Control for Plants and Production of Architectural Precast Concrete Products."
- D. Range Samples: Before fabricating architectural precast concrete units, produce a minimum of 3 sets of samples, approximately 16 sq. ft. in area, representing anticipated range of each color and texture on Project's units. Maintain one set of range samples at Project site and remaining range sample sets at manufacturer's plant as color and texture approval reference.

1.6 DELIVERY, STORAGE, AND HANDLING

- A. Deliver architectural precast concrete units in such quantities and at such times to limit unloading units temporarily on ground or other rehandling.
- B. Support units during shipment on nonstaining shock-absorbing material.
- C. Store units with adequate dunnage and bracing and protect units to prevent contact with soil, to prevent staining, and to prevent cracking, distortion, warping or other physical damage.
- D. Place stored units so identification marks are clearly visible, and units can be inspected.
- E. Handle and transport units in a manner that avoids excessive stresses that cause cracking or damage. Lift and support units only at designated points indicated on Shop Drawings.

PART 2 - PRODUCTS

2.1 MANUFACTURERS

- A. Fabricators: Subject to compliance with requirements, provide products manufactured from companies that are acceptable to Architect and that are designated as a PCI-certified plant for Group A, Category A1 - Architectural Precast Products.

2.2 PERFORMANCE CRITERIA

- A. Design Standards: Comply with ACI 318 and design recommendations of PCI MNL 120, "PCI Design Handbook - Precast and Prestressed Concrete," applicable to types of architectural precast concrete units indicated.
- B. Structural Performance: Provide architectural precast concrete units and connections capable of withstanding the following design loads within limits and under conditions indicated:
 - 1. Design Loads: Static loads, anticipated dynamic loading, including positive and negative wind loads, thermal movement loads, seismic loads, and erection forces as defined by applicable code are indicated on structural Drawings.

2. Design precast concrete units and connections to maintain clearances at openings, to allow for fabrication and construction tolerances, to accommodate live-load deflection, shrinkage and creep of primary building structure, and other building movements as follows:
 - a. Upward and downward movement of 1/2 inch.
 - b. Stair Treads and Landings: Design to support full dead load plus 100 psf live load.
3. Thermal Movements: Provide for in-plane thermal movements resulting from annual ambient temperature changes of 80 deg F.

2.3 MOLD MATERIALS

- A. Molds: Rigid, dimensionally stable, non-absorptive material, warp and buckle free, that provides continuous and true precast concrete surfaces within fabrication tolerances indicated; nonreactive with concrete and suitable for producing required finishes.
 1. Mold-Release Agent: Commercially produced form-release agent that does not bond with, stain or adversely affect precast concrete surfaces and does not impair subsequent surface or joint treatments of precast concrete.

2.4 REINFORCING MATERIALS

- A. Recycled Content of Steel Products: Postconsumer recycled content plus 1/2 of preconsumer recycled content not less than 60 percent.
- B. Plain-Steel Welded Wire Reinforcement: ASTM A1064, fabricated from as-drawn steel wire into flat sheets.
 1. Provide galvanized steel wire where concrete coverage will be less than 2 inches.
- C. Deformed-Steel Welded Wire Reinforcement: ASTM A497, flat sheet.
- D. Supports: Suspend reinforcement from back of mold or use bolsters, chairs, spacers, and other devices for spacing, supporting, and fastening reinforcing bars and welded wire reinforcement in place according to PCI MNL 117.

2.5 CONCRETE MATERIALS

- A. Portland Cement: ASTM C150, Type I or Type III, gray, unless otherwise indicated.
 1. For surfaces exposed to view in finished structure, use gray or white cement, of same type, brand, and mill source.
- B. Normal-Weight Aggregates: Except as modified by PCI MNL 117, ASTM C33, with coarse aggregates complying with Class 5S. Stockpile fine and coarse aggregates for each type of exposed finish from a single source (pit or quarry) for Project.
 1. Face-Mixture-Coarse Aggregates: Selected, hard, and durable; free of material that reacts with cement or causes staining; to match selected finish sample.
 - a. Gradation: Uniformly graded.
 2. Face-Mixture-Fine Aggregates: Selected, natural or manufactured sand compatible with coarse aggregate; to match approved finish sample.
- C. Coloring Admixture: ASTM C979, synthetic or natural mineral-oxide pigments or colored water-reducing admixtures, temperature stable, and nonfading.
 1. Products: Subject to compliance with requirements, provide one of the following:
 - a. Davis Colors: Mix-Ready.
 - b. Dayton Superior Corporation: Synthetic Iron Oxides.
 - c. Lambert Corporation: Lambco Color.
 - d. Sika Corporation: CHROMIX Admixtures.
 - e. Solomon Colors, Inc.: ColorFlo.
 2. Color: Selected by Architect from manufacturer's full range.

- D. Water: Potable; free from deleterious material that may affect color stability, setting, or strength of concrete and complying with chemical limits of PCI MNL 117.
- E. Air-Entraining Admixture: ASTM C260, certified by manufacturer to be compatible with other required admixtures.

2.6 STEEL CONNECTION MATERIALS

- A. Carbon-Steel Shapes and Plates: ASTM A36.
- B. Carbon-Steel Plate: ASTM A283, Grade C.
- C. Carbon-Steel Castings: ASTM A27, Grade 60-30.
- D. Carbon-Steel Bolts and Studs: ASTM A307, Grade A or ASTM F1554, Grade 36; carbon-steel, hex-head bolts and studs; carbon-steel nuts, ASTM A563; and flat, unhardened steel washers, ASTM F844.

2.7 ACCESSORIES

- A. Precast Accessories: Provide clips, hangers, high-density plastic or steel shims, and other accessories required to install architectural precast concrete units.

2.8 GROUT MATERIALS

- A. Nonmetallic, Nonshrink Grout: Packaged, nonmetallic, noncorrosive, nonstaining grout containing selected silica sands, portland cement, shrinkage-compensating agents, plasticizing and water-reducing agents, complying with ASTM C1107, Grade A for drypack and Grades B and C for flowable grout and of consistency suitable for application within a 30-minute working time. Water-soluble chloride ion content less than 0.06 percent by weight of cement when tested according to ASTM C1218.

2.9 CONCRETE MIXTURES

- A. Prepare design mixtures for each type of precast concrete required.
 - 1. Use a single design mixture for units with more than one major face or edge exposed.
 - 2. Where only one face of unit is exposed use either a single design mixture or separate mixtures for face and backup.
- B. Limit use of fly ash and ground granulated blast-furnace slag to 20 percent of portland cement by weight; limit metakaolin and silica fume to 10 percent of portland cement by weight.
- C. Design mixtures may be prepared by a qualified independent testing agency or by qualified precast plant personnel at architectural precast concrete fabricator's option.
- D. Limit water-soluble chloride ions to maximum percentage by weight of cement permitted by ACI 318 or PCI MNL 117 when tested according to ASTM C1218.
- E. Normal-Weight Concrete Mixtures: Proportion mixtures by either laboratory trial batch or field test data methods according to ACI 211.1, with materials to be used on Project, to provide normal-weight concrete with the following properties:
 - 1. Compressive Strength (28 Days): 5,000 psi minimum.
 - 2. Maximum Water-Cementitious Materials Ratio: 0.40.
- F. Water Absorption: 6 percent by weight or 14 percent by volume, tested according to ASTM C642, except for boiling requirement.
- G. Add air-entraining admixture at manufacturer's prescribed rate to result in concrete at point of placement having an air content complying with PCI MNL 117.

- H. When included in design mixtures, add other admixtures to concrete mixtures according to manufacturer's written instructions.

2.10 MOLD FABRICATION

- A. Molds: Accurately construct molds, mortar tight, of sufficient strength to withstand pressures due to concrete-placement operations and temperature changes. Coat contact surfaces of molds with release agent before reinforcement is placed. Avoid contamination of reinforcement by release agent.
- B. Maintain molds to provide completed architectural precast concrete units of shapes, lines, and dimensions indicated, within fabrication tolerances specified.
 - 1. Form joints are not permitted on faces exposed to view in finished Work.
 - 2. Edge and Corner Treatment: Uniformly radiused.

2.11 FABRICATION

- A. Cast-in Anchors, Inserts, Plates, Angles, and Other Anchorage Hardware: Fabricate anchorage hardware with sufficient anchorage and embedment to comply with design requirements. Accurately position for attachment of loose hardware, and secure in place during precasting operations. Locate anchorage hardware where it does not affect position of main reinforcement or concrete placement.
- B. Furnish loose hardware items including steel plates, clip angles, seat angles, anchors, dowels, cramps, hangers, and other hardware shapes for securing architectural precast concrete units to supporting and adjacent construction.
- C. Cast-in slots, holes, and other accessories in architectural precast concrete units as indicated on approved Shop Drawings.
- D. Reinforcement: Comply with recommendations in PCI MNL 117 for fabricating, placing, and supporting reinforcement.
- E. Reinforce architectural precast concrete units to resist handling, transportation, and erection stresses and specified in-place loads.
- F. Comply with requirements in PCI MNL 117 and requirements in this Section for measuring, mixing, transporting, and placing concrete. After concrete batching, no additional water may be added.
- G. Place concrete in a continuous operation to prevent cold joints or planes of weakness from forming in precast concrete units.
 - 1. Place backup concrete mixture to ensure bond with face-mixture concrete.
- H. Thoroughly consolidate placed concrete by internal and external vibration without dislocating or damaging reinforcement and built-in items, and minimize pour lines, honeycombing, or entrapped air voids on surfaces. Use equipment and procedures complying with PCI MNL 117.
 - 1. Place self-consolidating concrete without vibration according to PCI TR-6, "Interim Guidelines for the Use of Self-Consolidating Concrete in Precast/Prestressed Concrete Institute Member Plants." Ensure adequate bond between face and backup concrete, if used.
- I. Comply with PCI MNL 117 for hot- and cold-weather concrete placement.
- J. Cure concrete, according to requirements in PCI MNL 117, by moisture retention without heat or by accelerated heat curing using low-pressure live steam or radiant heat and moisture. Cure units until compressive strength is high enough to ensure that stripping does not have an effect on performance or appearance of final product.

- K. Discard and replace architectural precast concrete units that do not comply with requirements, including structural, manufacturing tolerance, and appearance, unless repairs meet requirements in PCI MNL 117 and Architect's approval.
- L. Splash Blocks: Precast concrete, top surface curbed on 3 sides, and sloped from back to front for proper drainage; with fabricator's standard reinforcing. Provide at locations indicated on Drawings.
 - 1. Size: 16 by 32 by 3-1/2 inches.
 - 2. Steel Bar Reinforcement: ASTM A615, Grade 60, deformed. Use hot-dip galvanized steel where concrete coverage will be less than 2 inches.
 - 3. Exposed Surface Finish: Smooth form finish. Comply with ACI 301.
 - 4. Color: Natural, consistent in color.
 - 5. Concrete Design Mix: Not less than 5,000 psi, in place, at 28 days.
 - 6. Air-Entraining Admixture: As recommended by splash block manufacturer for proper quantity of admixture required for use in mix to achieve specified air content, with minimum of 5 percent.
 - a. Do not use calcium chloride or fly ash.

2.12 FABRICATION TOLERANCES

- A. Fabricate architectural precast concrete units to shapes, lines, and dimensions indicated so each finished unit complies with PCI MNL 117 and PCI MNL 135 product tolerances as well as position tolerances for cast-in items.

2.13 FINISHES

- A. Exposed faces shall be free of joint marks, grain, and other obvious defects. Corners, including false joints, shall be uniform, straight, and sharp. Finish exposed-face surfaces of architectural precast concrete units to match approved mockups and as follows:
 - 1. As-Cast Surface Finish: Provide surfaces to match approved sample for acceptable surface, air voids, sand streaks, and honeycomb.
 - 2. Broom Finish: Apply slightly roughened non-slip surface with fiber-bristle broom perpendicular to main traffic route of precast concrete treads and Landings.
- B. Finish unexposed surfaces of architectural precast concrete units with as cast finish.

PART 3 - EXECUTION

3.1 EXAMINATION

- A. Examine supporting structural frame or foundation and conditions for compliance with requirements for installation tolerances, bearing surface tolerances, and other conditions affecting performance of Work.
- B. Do not install precast concrete units until supporting cast-in-place concrete has attained minimum allowable design compressive strength and supporting steel or other structure is structurally ready to receive loads from precast concrete units.
- C. Proceed with installation only after unsatisfactory conditions have been corrected.

3.2 INSTALLATION

- A. Install clips, hangers, bearing pads, and other accessories required for connecting architectural precast concrete units to supporting members and backup materials.
- B. Erect architectural precast concrete level, plumb, and square within specified allowable tolerances. Provide temporary supports and bracing as required to maintain position, stability, and alignment of units until permanent connections are completed.

1. Maintain horizontal and vertical joint alignment and uniform joint width as erection progresses.
 2. Unless otherwise indicated, maintain uniform joint widths of 3/4 inch.
- C. Connect architectural precast concrete units in position by bolting or as otherwise indicated on Shop Drawings. Remove temporary shims, wedges, and spacers as soon as practical after connecting and grouting are completed.
1. Visually inspect welds and remove, reweld, or repair incomplete and defective welds.
- D. At bolted connections, use lock washers, tack welding, or other approved means to prevent loosening of nuts after final adjustment.
1. Where slotted connections are used, verify bolt position and tightness. For sliding connections, properly secure bolt but allow bolt to move within connection slot.
- 3.3 ERECTION TOLERANCES
- A. Erect architectural precast concrete units level, plumb, square, and in alignment without exceeding noncumulative erection tolerances of PCI MNL 117, Appendix I.
- 3.4 REPAIRS
- A. Repair architectural precast concrete units if permitted by Architect. Architect reserves the right to reject repaired units that do not comply with requirements.
- B. Mix patching materials and repair units so cured patches blend with color, texture, and uniformity of adjacent exposed surfaces and show no apparent line of demarcation between original and repaired Work, when viewed in typical daylight illumination from 20 feet.
- C. Prepare and repair damaged galvanized coatings with galvanizing repair paint according to ASTM A780.
- D. Wire brush, clean, and paint damaged prime-painted components with same type of shop primer.
- E. Remove and replace damaged architectural precast concrete units when repairs do not comply with requirements.
- 3.5 CLEANING
- A. Clean surfaces of precast concrete units exposed to view.
- B. Clean mortar, plaster, fireproofing, weld slag, and other deleterious material from concrete surfaces and adjacent materials immediately.
- C. Clean exposed surfaces of precast concrete units after erection and completion of joint treatment to remove weld marks, other markings, dirt, and stains.
1. Perform cleaning procedures, if necessary, according to precast concrete fabricator's recommendations. Protect other Work from staining or damage due to cleaning operations.
 2. Do not use cleaning materials or processes that could change the appearance of exposed concrete finishes or damage adjacent materials.

END OF SECTION 034500

SECTION 035413
GYPSUM CEMENT UNDERLAYMENT

PART 1 - GENERAL

1.1 SUMMARY

- A. Section Includes:
 - 1. Self-leveling, gypsum cement underlayment for application below interior floor coverings.
- B. Related Requirements:
 - 1. Section 134816 – Manufactured Sound Control Components, for resilient isolation systems.

1.2 ADMINISTRATIVE REQUIREMENTS

- A. Coordination:
 - 1. Coordinate application of cement underlayment with requirements of floor-covering products and adhesives, specified in Division 09 Sections, to ensure compatibility of products.
- B. Preinstallation Meeting: Conduct meeting at Project site.

1.3 ACTION SUBMITTALS

- A. Product Data: For the following:
 - 1. Gypsum cement underlayment.
 - 2. Reinforcement.
 - 3. Primer.
 - 4. Corrosion-resistant coating.
 - 5. Surface sealer.
 - 6. Sound control mat.
- B. Sustainable Design Submittals:
 - 1. Product Data: For coatings, indicating VOC content.
 - 2. Laboratory Test Reports: For coatings, indicating compliance with requirements for low-emitting materials.
- C. Shop Drawings: Include plans indicating substrates, locations, and average depths of underlayment based on survey of substrate conditions.

1.4 INFORMATIONAL SUBMITTALS

- A. Qualification Data: For Installer.
- B. Test Reports: From qualified testing agency for the following:
 - 1. **[Fire-resistant ratings.]**
 - 2. STC-rated assemblies.
 - 3. IIC-rated assemblies.

1.5 QUALITY ASSURANCE

- A. Installer Qualifications: Installer who is approved by manufacturer for application of cement underlayment products required for this Project.

1.6 FIELD CONDITIONS

- A. Environmental Limitations: Comply with manufacturer's written instructions for substrate temperature, ventilation, ambient temperature and humidity, and other conditions affecting underlayment performance.
 - 1. Place gypsum cement underlayments only when ambient temperature and temperature of substrates are between 50 and 80 deg F.

PART 2 - PRODUCTS

2.1 PERFORMANCE CRITERIA

- A. Fire-Resistance Ratings: Comply with ASTM E119; testing by a qualified testing agency. Identify products with appropriate markings of applicable testing agency.
 - 1. Indicate design designations from UL's "Fire Resistance Directory" or from listings of another qualified testing agency.
- B. STC-Rated Assemblies: For STC-rated assemblies, provide materials and construction identical to those tested in assembly indicated, according to ASTM E90 and classified according to ASTM E413 by an independent testing agency.
 - 1. STC Rating: Field-tested minimum of 50 unless indicated otherwise on Drawings.
- C. IIC-Rated Assemblies: For IIC-rated assemblies, provide materials and construction identical to those tested in assembly indicated, according to ASTM E492 and classified according to ASTM E989 by an independent testing agency.
 - 1. IIC Rating: Field-tested minimum of 50 unless indicated otherwise on Drawings.

2.2 GYPSUM CEMENT UNDERLAYMENTS

- A. Gypsum Cement Underlayment: Self-leveling, gypsum cement product that can be applied in minimum uniform thickness of 1/8 inch to match adjacent floor elevations.
 - 1. Products: Subject to compliance with requirements, provide one of the following:
 - a. Ardex Americas: ARDEX K 22 F.
 - b. Dependable, LLC: GSL-K2.6.
 - c. Hacker Industries, Inc.: Firm-Fill 3310.
 - d. MAPEI Corporation: Planitex SL.
 - e. Maxxon Corporation: Gyp-Crete 2000/3.2K.
 - f. Schönox, HPS North America, Inc.: Schönox AP.
 - g. USG Corporation: USG Levelrock 3500 Green Floor Underlayment.
 - 2. Cement Binder: Gypsum or blended gypsum cement as defined by ASTM C219.
 - 3. Compressive Strength: Not less than 3,200 psi at 28 days when tested according to ASTM C472.
 - 4. Dry Density: Maximum 120 lbs./cu. ft.
 - 5. Minimum Thickness: 1 inch.
 - 6. Final Set Time: Minimum 90 minutes.
 - 7. Underlayment Additive: Resilient-emulsion product of underlayment manufacturer, formulated for use with underlayment when applied to substrate and conditions indicated.
 - 8. Provide products that are GREENGUARD Certified for Indoor Air Quality.
- B. Aggregate: Well-graded, washed gravel, 1/8 to 1/4 inch; or coarse sand as recommended by underlayment manufacturer.
 - 1. Provide aggregate when recommended in writing by underlayment manufacturer for underlayment thickness required.
- C. Water: Potable and at a temperature of not more than 70 deg F.

- D. Reinforcement: For underlayment applied to wood substrates, provide galvanized metal lath or other corrosion-resistant reinforcement recommended in writing by underlayment manufacturer.
 - E. Primer: Product of underlayment manufacturer recommended in writing for substrate, conditions, and application indicated.
 - 1. Verify primers have VOC content of 100 g/L or less.
 - 2. Low-Emitting Materials: Verify primers comply with testing and product requirements of California Department of Public Health's "Standard Method for the Testing and Evaluation of Volatile Organic Chemical Emissions from Indoor Sources Using Environmental Chambers."
 - F. Corrosion-Resistant Coating: Recommended in writing by underlayment manufacturer for metal substrates.
 - 1. Verify coating have VOC content of 100 g/L or less.
 - 2. Low-Emitting Materials: Verify coating complies with testing and product requirements of California Department of Public Health's "Standard Method for the Testing and Evaluation of Volatile Organic Chemical Emissions from Indoor Sources Using Environmental Chambers."
 - G. Surface Sealer: Designed to reduce porosity as recommended by manufacturer for type of floor covering to be applied to underlayment.
- 2.3 SOUND CONTROL MATS
- A. Specified in Section 134816 – Manufactured Sound Control Components.
- 2.4 EXAMINATION
- A. Examine substrates, with Installer present, for conditions affecting performance of Work.
 - B. Proceed with application only after unsatisfactory conditions have been corrected.
- 2.5 PREPARATION
- A. Prepare and clean substrate according to manufacturer's written instructions.
 - 1. Treat nonmoving substrate cracks according to manufacturer's written instructions to prevent cracks from telegraphing (reflecting) through underlayment.
 - 2. Fill substrate voids to prevent underlayment from leaking.
 - B. Concrete Substrates: Mechanically remove, according to manufacturer's written instructions, laitance, glaze, efflorescence, curing compounds, form-release agents, dust, dirt, grease, oil, and other contaminants that might impair underlayment bond.
 - 1. Moisture Testing: Perform tests so that each test area does not exceed 200 sq. ft., and perform no fewer than 3 tests in each installation area and with test areas evenly spaced in installation areas.
 - a. Anhydrous Calcium Chloride Test, ASTM F1869: Proceed with installation only after substrates do not exceed a maximum moisture-vapor-emission rate of 3 lb of water/1,000 sq. ft. in 24 hours.
 - b. Relative Humidity Test: Using in situ probes, ASTM F2170. Proceed with installation only after substrates have a maximum 85 percent relative humidity level measurement, or as recommended by hydraulic cement underlayment manufacturer.
 - C. **[Wood Substrates: Mechanically fasten loose boards and panels to eliminate substrate movement and squeaks. Sand to remove coatings that might impair underlayment bond and remove sanding dust.]**
 - 1. Install underlayment reinforcement recommended in writing by manufacturer.
 - D. Metal Substrates: Mechanically remove, according to manufacturer's written instructions, rust, foreign matter, and other contaminants that might impair underlayment bond. Apply corrosion-

resistant coating compatible with underlayment if recommended in writing by underlayment manufacturer.

- E. Nonporous Substrates: For ceramic tile, quarry tile, and terrazzo substrates, remove waxes, sealants, and other contaminants that might impair underlayment bond; prepare surfaces according to manufacturer's written instructions.
- F. Adhesion Tests: After substrate preparation, test substrate for adhesion with underlayment according to manufacturer's written instructions.
- G. Sound Control Mats: Comply with Section 134816 – Manufactured Sound Control Components.

2.6 INSTALLATION

- A. Mix and install cement underlayment components according to manufacturer's written instructions.
 - 1. Close areas to traffic during underlayment installation and for time period after installation recommended in writing by manufacturer.
 - 2. Coordinate installation of components to provide optimum adhesion to substrate and between coats.
 - 3. At substrate expansion, isolation, and other moving joints, allow joint of same width to continue through underlayment.
- B. Apply primer over prepared substrate at manufacturer's recommended spreading rate.
- C. Install cement underlayment to produce uniform, level surface.
 - 1. Install a final layer without aggregate to product surface.
 - 2. Feather edges to match adjacent floor elevations.
- D. Cure cement underlayment according to manufacturer's written instructions. Prevent contamination during installation and curing processes.
- E. Do not install floor coverings over cement underlayment until after time period recommended in writing by underlayment manufacturer.
- F. Apply surface sealer at rate recommended by manufacturer.
- G. Remove and replace cement underlayment areas that evidence lack of bond with substrate, including areas that emit a "hollow" sound when tapped.

2.7 INSTALLATION TOLERANCES

- A. Finish and measure surface, so gap at any point between gypsum cement underlayment surface and an unleveled, freestanding, 10 foot long straightedge resting on 2 high spots and placed anywhere on surface does not exceed **[1/4 inch] [3/16 inch] [1/8 inch] [1/8 inch and 1/16 inch in 2 feet]**.

2.8 PROTECTION

- A. Protect cement underlayment from concentrated and rolling loads for remainder of construction period.

END OF SECTION 035413

SECTION 042000

UNIT MASONRY

PART 1 - GENERAL

1.1 SUMMARY

A. Section Includes:

1. Concrete masonry units (CMUs).
2. Decorative concrete masonry units.
3. Clay face brick.
4. Hollow brick.
5. Mortar and grout.
6. Steel reinforcing bars.
7. Masonry-joint reinforcement.
8. Ties and anchors.
9. Embedded flashing.
10. Miscellaneous masonry accessories.

B. Products Furnished, But Not Installed, Under This Section:

1. Dovetail slots for masonry anchors, installed under Section 033000 – Cast-in-Place Concrete.

C. Products Installed but not Furnished under This Section:

1. Architectural precast concrete units.
2. Stone masonry units.
3. Cast stone trim in unit masonry.
4. Steel lintels in unit masonry.
5. Steel shelf angles for supporting unit masonry.
6. Manufactured reglets in masonry joints for metal flashing.
7. Cavity wall insulation.

1.2 DEFINITIONS

A. CMU(s): Concrete masonry unit(s).

B. Reinforced Masonry: Masonry containing reinforcing steel in grouted cells.

C. Special Reinforced Masonry Shear Walls (SRMSW): Masonry walls required to meet strict reinforcing and material requirements per TMS 402, Section 7.3.2.6, and TMS 602. SRMSW are Project's designated type of SFRS.

D. SFRS: Seismic Force Resisting System.

E. Self-Consolidating Grout (SCG): A highly fluid and stable grout, typically with admixtures, that remains homogeneous when placed and does not require puddling or vibration for consolidation.

1.3 ADMINISTRATIVE REQUIREMENTS

A. Preinstallation Meeting: Conduct meeting at Project site.

1. Attendance: Owner, Architect, Contractor, and Installers and other entities directly affecting Work of this Section.
2. Time: Minimum of 3 months prior to starting Work of this Section.
3. Agenda: Address the following items at preinstallation meeting.
 - a. Structural concept.
 - b. Method and sequence of masonry construction.

- c. Special masonry details.
- d. Standard of workmanship.
- e. Quality control requirements.
- f. Job organization.
- g. Other pertinent topics or issues.

1.4 ACTION SUBMITTALS

- A. Product Data: For each type of product.
- B. Sustainable Design Submittals:
 - 1. Environmental Product Declaration (EPD): For each product.
- C. Shop Drawings: For the following:
 - 1. Masonry Units: Show sizes, profiles, coursing, and locations of special shapes.
 - 2. **[Stone Trim Units: Show sizes, profiles, and locations of each stone trim unit required.]**
 - 3. [Reinforcing Steel: Detail bending, lap lengths, and placement of unit masonry reinforcing bars. Comply with ACI 315. Show elevations of reinforced walls, including control joints.
 - 4. Fabricated Flashing: Detail corner units, end-dam units, and other special applications.
- D. Samples for Verification: For each type and color of the following:
 - 1. Exposed **[Decorative]** CMUs.
 - 2. Clay face **[Hollow]** brick, in the form of straps of 5 or more bricks.
 - 3. Special brick shapes.
 - 4. Pigmented Mortar. Make Samples using same sand and mortar ingredients to be used on Project.
 - 5. Wicking material and cavity vents.
 - 6. Accessories embedded in masonry.

1.5 INFORMATIONAL SUBMITTALS

- A. List of Materials Used in Constructing Mockups: List generic product names together with manufacturers, manufacturers' product names, model numbers, lot numbers, batch numbers, source of supply, and other information as required to identify materials used. Include mix proportions for mortar and grout and source of aggregates.
 - 1. Submittal is for information only. Receipt of list does not constitute approval of deviations from Contract Documents unless such deviations are specifically approved in writing by Architect.
- B. Material Certificates: For each type and size of the following:
 - 1. Masonry units.
 - a. Include data on material properties or material test reports substantiating compliance with requirements.
 - b. **[For brick, include size-variation data verifying that actual range of sizes falls within specified tolerances.]**
 - c. **[For exposed brick, include test report for efflorescence according to ASTM C67.]**
 - d. For masonry units, include data and calculations establishing average net-area compressive strength of units.
 - 2. Integral water repellent used in CMUs.
 - 3. Cementitious materials. Include name of manufacturer, brand name, and type.
 - 4. Mortar admixtures.
 - 5. Preblended, dry mortar mixes. Include description of type and proportions of ingredients.
 - 6. Grout mixes. Include description of type and proportions of ingredients.
 - 7. Reinforcing bars. Clearly indicate compliance with specified ASTM Standards.
 - 8. Joint reinforcement.
 - 9. Anchors, ties, and metal accessories.

- C. Mix Designs: For each type of mortar and grout. Include description of type and proportions of ingredients.
 - 1. Include test reports, according to ASTM C1019, for grout mixes required to comply with compressive strength requirement.
- D. Statement of Compressive Strength of Masonry: For each assembly of masonry unit, grout, and mortar types, provide statement of average net-area compressive strength of masonry units, mortar type, and resulting net-area compressive strength of each masonry assembly determined according to TMS 402/602.
- E. Cold-Weather and Hot-Weather Procedures: Detailed description of methods, materials, and equipment to be used to comply with requirements.

1.6 QUALITY ASSURANCE

- A. Sample Panels: Build sample panels to verify selections made under Sample submittals and to demonstrate aesthetic effects. Comply with requirements in Section 014339 – Mockups.
 - 1. Build sample panels for each color scheme.
 - 2. Build sample panels for each type of exposed unit masonry construction typical exterior wall typical exterior and interior walls in sizes approximately 48 inches long by 48 inches high by full thickness.
 - 3. Build sample panels facing south.
 - 4. **[Where masonry is to match existing, erect panels adjacent and parallel to existing surface.**
 - 5.]Clean 1/2 of exposed faces of sample panel with masonry cleaner as indicated.
 - 6. Protect approved sample panel from elements with weather-resistant membrane.
 - 7. Approval of sample panel is for color, texture, and blending of masonry units; relationship of mortar and sealant colors to masonry unit colors; tooling of joints; and aesthetic qualities of workmanship; and other material and construction qualities specifically approved by Architect in writing.
 - a. Approval of sample panel does not constitute approval of deviations from Contract Documents contained in sample panel unless such deviations are specifically approved by Architect in writing.
- B. Mockups: Build mockups in compliance with Section 014339 – Mockups to verify selections made under Sample submittals, to demonstrate aesthetic effects, and to set quality standards for materials and execution.
 - 1. Unless indicated otherwise by Architect, build mockups for typical exterior wall in sizes approximately 96 inches Insert dimension long by 72 inches high by full thickness, including face and backup wythes and accessories.
 - a. Each type of veneer material incorporating respective types of joint reinforcement, ties, and anchors:
 - 1) Anchored stone masonry.
 - 2) Cast stone masonry
 - 3) Architectural precast concrete.
 - 4) Brick veneer.
 - 5) Exterior insulation finish system (EIFS).
 - 6) Other materials per Project requirements.
 - b. Sealant-filled joint at least 16 inches long in exterior wall mockup.
 - c. Lower corner of window opening at upper corner of exterior wall mockup. Make opening approximately 12 inches wide by 16 inches high.
 - d. Through-wall flashing installed for a 24 inch length in corner of exterior wall mockup approximately 16 inches down from top of mockup, with a 12 inch length of flashing left exposed to view (omit masonry above half of flashing) . Include an end dam condition.

- e. Metal **[Wood]** studs, sheathing, water-resistive barrier, sheathing joint-and-penetration treatment, air barrier, veneer anchors, flashing[, **cavity drainage material**], and weep holes in exterior masonry-veneer wall mockup.
 - f. **[Include clay face brick on one face of interior unit masonry wall mockup.]**
 - g. Cavity wall conditions including cavity drainage material, weep holes in exterior masonry-veneer with wicks and vents.
 - h. Corner of window opening framed with each type of exterior adjacent finish.
- 2. [Where masonry is to match existing, erect mockup adjacent and parallel to existing surface.**
- 3.]Clean 1/2 of exposed faces of mockup with masonry cleaner as indicated.
 - 4. Protect approved mockups from elements with weather-resistant membrane.
 - 5. Approval of mockups is for color, texture, and blending of masonry units; relationship of mortar and sealant colors to masonry unit colors; tooling of joints; and aesthetic qualities of workmanship.
 - a. Approval of mockups is also for other material and construction qualities specifically approved by Architect in writing.
 - b. Approval of mockups does not constitute approval of deviations from Contract Documents contained in mockups unless such deviations are specifically approved by Architect in writing.
 - 6. Subject to compliance with requirements, approved mockups may become part of completed Work if undisturbed at time of Substantial Completion.

1.7 DELIVERY, STORAGE, AND HANDLING

- A. Store masonry units on elevated platforms in a dry location. If units are not stored in an enclosed location, cover tops and sides of stacks with waterproof sheeting, securely tied. If units become wet, do not install until they are dry.
- B. Store cementitious materials on elevated platforms, under cover, and in a dry location. Do not use cementitious materials that have become damp.
- C. Store aggregates where grading and other required characteristics can be maintained and contamination avoided.
- D. Deliver preblended, dry mortar mix in moisture-resistant containers. Store preblended, dry mortar mix in delivery containers on elevated platforms in a dry location or in covered weatherproof dispensing silos.
- E. Store masonry accessories, including metal items, to prevent corrosion and accumulation of dirt and oil.

1.8 FIELD CONDITIONS

- A. Protection of Masonry: During construction, cover tops of walls, projections, and sills with waterproof sheeting at end of each day's Work. Cover partially completed masonry when construction is not in progress.
 - 1. Extend cover a minimum of 24 inches down both sides of walls, and hold cover securely in place.
 - 2. Where one wythe of multiwythe masonry walls is completed in advance of other wythes, secure cover a minimum of 24 inches down face next to unconstructed wythe, and hold cover in place.
- B. Do not apply uniform floor or roof loads for at least 12 hours and concentrated loads for at least 3 days after building masonry walls or columns.
- C. Stain Prevention: Prevent grout, mortar, and soil from staining face of masonry to be left exposed or painted. Immediately remove grout, mortar, and soil that come in contact with such masonry.

1. Protect base of walls from rain-splashed mud and from mortar splatter by spreading coverings on ground and over wall surface.
 2. Protect sills, ledges, and projections from mortar droppings.
 3. Protect surfaces of window and door frames, as well as similar products with painted and integral finishes, from mortar droppings.
 4. Turn scaffold boards near the wall on edge at end of each day to prevent rain from splashing mortar and dirt onto completed masonry.
- D. Cold-Weather Requirements: Do not use frozen materials or materials mixed or coated with ice or frost. Do not build on frozen substrates. Remove and replace unit masonry damaged by frost or by freezing conditions. Comply with cold-weather construction requirements contained in TMS 602.
1. Cold-Weather Cleaning: Use liquid cleaning methods only when air temperature is 40 deg F and higher and will remain so until masonry has dried, but not less than seven days after completing cleaning.
- E. Hot-Weather Requirements: Comply with hot-weather construction requirements contained in TMS 602.

PART 2 - PRODUCTS

2.1 MANUFACTURERS

- A. Manufacturers: Subject to compliance with requirements, provide products from one of the following:
1. Basalite Concrete Products, LLC.
 2. Central Pre-Mix Concrete Products Co.
 3. Eastside Masonry Products.
 4. Mutual Materials Co.
 5. Western Materials.
 6. Willamette Graystone, Inc.
 7. Approved substitutions.
- B. Source Limitations for Masonry Units: Obtain exposed masonry units of a uniform texture and color, or a uniform blend within ranges accepted for these characteristics, from single source from single manufacturer for each product required.
- C. Source Limitations for Mortar Materials: Obtain mortar ingredients of a uniform quality, including color for exposed masonry, from single manufacturer for each cementitious component and from single source or producer for each aggregate.

2.2 PERFORMANCE CRITERIA

- A. Provide unit masonry that develops indicated net-area compressive strengths at 28 days.
1. Determine net-area compressive strength of masonry from average net-area compressive strengths of masonry units and mortar types (unit-strength method) according to TMS 402/602.
- B. Compressive Strength of Special Reinforced Masonry Shear Walls (SRMSW): $f'm=2,000$ psi.

2.3 UNIT MASONRY, GENERAL

- A. Masonry Standard: Comply with TMS 602, except as modified by requirements in Contract Documents.
- B. Defective Units: Referenced masonry unit standards may allow a certain percentage of units to contain chips, cracks, or other defects exceeding limits stated. Do not use units where such defects are exposed in completed Work and will be within 20 feet vertically and horizontally of a walking surface.

- C. [Fire-Resistance Ratings: Comply with requirements for fire-resistance-rated assembly designs indicated.]
 - 1. **[Where fire-resistance-rated construction is indicated, units shall be listed and labeled by a qualified testing agency acceptable to authorities having jurisdiction.]**

2.4 CONCRETE MASONRY UNITS

- A. [Regional Materials: Verify CMUs are manufactured within 100 miles of Project site from aggregates[and cement] that have been extracted, harvested, or recovered, as well as manufactured, within 100 miles of Project site.]
- B. Shapes: Provide shapes indicated and as follows, with exposed surfaces matching exposed faces of adjacent units unless otherwise indicated.
 - 1. Provide special shapes for lintels, corners, jambs, sashes, movement joints, headers, bonding, and other special conditions.
 - 2. Provide square-edged units for outside corners unless otherwise indicated.
 - 3. Provide bullnose units for outside vertical corners in locker rooms and where indicated, except as follows:
 - a. First course at finished floor.
 - b. Courses intersecting with ceiling plane.
 - 4. Provide CMU sill units at exterior windows and where indicated unless otherwise indicated.
 - 5. Provide standard CMU with 2 cell or open end configuration.
- C. Integral Water Repellent: Provide units made with integral water repellent for exposed units and where indicated.
 - 1. Integral Water Repellent: Liquid polymeric, integral water-repellent admixture that does not reduce flexural bond strength. Units made with integral water repellent, when tested according to ASTM E514 as wall assembly made with mortar containing integral water-repellent manufacturer's mortar additive, with test period extended to 24 hours, shall show no visible water or leaks on the back of test specimen.
 - a. Products: Subject to compliance with requirements, provide one of the following:
 - 1) ACM Chemistries: RainBloc.
 - 2) BASF Corporation: MasterPel 240 or MasterPel 200HD.
 - 3) Euclid Chemical Company (The): Eucon Blocktite.
 - 4) GCP Applied Technologies Inc.: Dry-Block.
 - 5) Moxie International: Moxie Shield 1800 Admixture.
- D. CMUs: ASTM C90.
 - 1. Unit Compressive Strength: Provide units with minimum average net-area compressive strength of 1,900 **[2,000]** psi.
 - 2. Density Classification: Normal weight unless otherwise indicated.
 - 3. Size (Width): Manufactured to dimensions 3/8 inch less than nominal dimensions.
 - 4. Exposed Faces: Provide color and texture matching range represented by Architect's sample.
- E. Concrete Building Brick: ASTM C55.
 - 1. Unit Compressive Strength: Provide units with minimum average net-area compressive strength of 2,500 psi.
 - 2. Density Classification: Normal weight unless otherwise indicated.
 - 3. Size: As required to make adjustment to CMU construction.
- F. Decorative CMUs: ASTM C90.
 - 1. Products: Subject to compliance with requirements, provide one of the following:
 - a. Basalite Concrete Products, LLC.
 - b. Echelon Masonry: (ground face) (Astra-Glaze).
 - c. Elgin Butler.
 - d. Midwest Block & Brick: (Astra-Glaze).

- e. Mutual Materials Co.
- f. Spectra-Glaze.
- 2. Unit Compressive Strength: Provide units with minimum average net-area compressive strength of 2,150 psi.
- 3. Density Classification: Normal weight.
- 4. Size (Width): Manufactured to dimensions specified in "CMUs" Paragraph.
- 5. Pattern and Texture:
 - a. Standard pattern, ground finish.
 - 1) Provide ground finish units with factory-applied sealant on each ground surface to facilitate cleaning on Project site. For exterior applications, provide concrete masonry units with integral water repellent and factory-applied sealer. After final clean down, apply coat of acrylic highlight sealer to ground finish units.
 - b. Standard pattern, split-face finish.
 - c. Standard pattern, split-ribbed finish.
 - d. Scored vertically so units laid in running bond appear as square units laid in stacked bond, standard finish.
 - e. Triple scored vertically so units laid in running bond appear as vertical units laid in stacked bond (soldier courses), standard finish.
- 6. Colors: As selected by Architect from manufacturer's full range.
- 7. Special Aggregate: Provide units made with aggregate matching aggregate in Architect's sample.

G. **[Sound Absorbing CMU: ASTM C90, manufactured with wide, funnel-shaped slots opening into a 2 chamber cavity, with tops completely closed and edges of slots and ends straight and clean.]**

2.5 LINTELS

- A. See structural Drawings for types and locations of lintels.
- B. General: Provide one of the following.
 - 1. Concrete Lintels: ASTM C1623, matching CMUs in color, texture, and density classification; and with reinforcing bars indicated. Provide lintels with net-area compressive strength not less than CMUs.
 - 2. Concrete Lintels: Precast or formed-in-place concrete lintels complying with requirements in Section 033000 – Cast-in-Place Concrete and with reinforcing bars indicated.
 - 3. Masonry Lintels: Prefabricated or built-in-place masonry lintels made from bond beam CMUs with reinforcing bars placed as indicated and filled with coarse grout. Cure precast lintels before handling and installing. Temporarily support built-in-place lintels until cured.

2.6 BRICK

- A. General: Provide shapes indicated and as follows, with exposed surfaces matching finish and color of exposed faces of adjacent units:
 - 1. For ends of sills and caps and for similar applications that would otherwise expose unfinished brick surfaces, provide units without cores or frogs and with exposed surfaces finished.
 - 2. Provide special shapes for applications where stretcher units cannot accommodate special conditions, including those at corners, movement joints, bond beams, sashes, and lintels.
 - 3. Provide special shapes for applications requiring brick of size, form, color, and texture on exposed surfaces that cannot be produced by sawing.
 - 4. Provide special shapes for applications where shapes produced by sawing would result in sawed surfaces being exposed to view.
- B. Face Brick: Facing brick complying with ASTM C216.
 - 1. **[Manufacturers: Subject to compliance with requirements, provide products by one of the following:]**

2. Basis-of-Design Manufacturer: Subject to compliance with requirements, provide products indicated in Exterior Materials Schedule or approved substitutions:
3. **[Basis-of-Design Manufacturer: Subject to compliance with requirements, provide products by Name of Company or approved substitutions:]**
 - a. Acme-Ochs Brick and Stone.
 - b. Belden Brick Company.
 - c. Endicott Clay Products Company.
 - d. Glen-Gery Corporation.
 - e. Interstate Bricks.
 - f. Mutual Materials Co.
 - g. Pacific Clay Products, Inc.
 - h. Approved substitutions.
4. Brick Type 1:
 - a. Style: Extruded.
 - b. Grade: SW.
 - c. Type: FBX.
 - d. Unit Compressive Strength: Provide units with minimum average net-area compressive strength of 3,350 psi.
 - e. Initial Rate of Absorption: Less than 30 g per 30 square inch per minute when tested per ASTM C67.
 - f. Efflorescence: Provide brick that has been rated "not effloresced" when tested per ASTM C67.
 - g. Modular Size (Actual Dimensions): 3-5/8 inches wide, 2-1/4 inches high, 7-5/8 inches long.
 - h. Economy Size (Actual Dimensions): 3-5/8 inches wide, 3-5/8 inches high, 7-5/8 inches long.
 - i. Norman Size (Actual Dimensions): 3-5/8 inches wide, 2-1/4 inches high, 11-5/8 inches long.
 - j. Utility Size (Actual Dimensions): 3-5/8 inches wide, 3-5/8 inches high, 11-5/8 inches long.
 - k. Collections:
 - l. Colors:
 - m. Textures:
 - n. Type:
 - o. Mix:
 - p. Application: Use where brick is exposed unless otherwise indicated.
 - q. Where shown to "match existing, provide face brick matching color range, texture, and size of existing adjacent brickwork.
5. Brick Type 2:
 - a. Style: Extruded.
 - b. Grade: SW.
 - c. Type: FBX.
 - d. Unit Compressive Strength: Provide units with minimum average net-area compressive strength of 3,350 psi.
 - e. Initial Rate of Absorption: Less than 30 g per 30 square inch per minute when tested per ASTM C67.
 - f. Efflorescence: Provide brick that has been rated "not effloresced" when tested per ASTM C67.
 - g. Modular Size (Actual Dimensions): 3-5/8 inches wide, 2-1/4 inches high, 7-5/8 inches long.
 - h. Economy Size (Actual Dimensions): 3-5/8 inches wide, 3-5/8 inches high, 7-5/8 inches long.
 - i. Norman Size (Actual Dimensions): 3-5/8 inches wide, 2-1/4 inches high, 11-5/8 inches long.

- j. Utility Size (Actual Dimensions): 3-5/8 inches wide, 3-5/8 inches high, 11-5/8 inches long.
- k. Collections:
- l. Colors:
- m. Textures:
- n. Type: Stocking.
- o. Mix:
- p. Application: Use where brick is exposed unless otherwise indicated.
- q. Where shown to "match existing, provide face brick matching color range, texture, and size of existing adjacent brickwork.

C. Hollow Brick: ASTM C652.

- 1. Manufacturers: Subject to compliance with requirements, provide products by one of the following:
- 2. Basis-of-Design Manufacturer: Subject to compliance with requirements, provide products by **Name of Company** or approved substitutions:
 - a. Acme-Ochs Brick and Stone.
 - b. Belden Brick Company.
 - c. Endicott Clay Products Company.
 - d. Glen-Gery Corporation.
 - e. Interstate Bricks.
 - f. Mutual Materials Co.
 - g. Pacific Clay Products, Inc.
 - h. Approved substitutions.
- 3. Style: Extruded.
- 4. Grade: SW [**MW or SW**], Class H40V (void areas between 25 and 40 percent of gross cross-sectional area) [**Class H60V (void areas between 40 and 60 percent of gross cross-sectional area)**],
- 5. Type: HBS [**HBX**] [**HBA**] [**HBB**]
- 6. Unit Compressive Strength: Provide units with minimum average net-area compressive strength of [**3,350 psi**] [**4,150 psi**] [**4,950 psi**] [**6,200 psi**] [**6,600 psi**] [**8,250 psi**] [**As indicated by manufacturer's product designation**].
- 7. Efflorescence: Provide brick that has been tested according to ASTM C67 and is rated "not effloresced."
- 8. Size (Actual Dimensions): [**5-1/2 inches** wide by **3-1/2 inches** high by **11-1/2 inches** long] [or] [**5-5/8 inches** wide by **3-5/8 inches** high by **11-5/8 inches** long].
- 9. Size (Actual Dimensions): [**7-1/2 inches** wide by **3-1/2 inches** high by **11-1/2 inches** long] [or] [**7-5/8 inches** wide by **3-5/8 inches** high by **11-5/8 inches** long].
- 10. Size (Actual Dimensions): [**5-1/2 inches** wide by **3-1/2 inches** high by **15-1/2 inches** long] [or] [**5-5/8 inches** wide by **3-5/8 inches** high by **15-5/8 inches** long].
- 11. Size (Actual Dimensions): [**7-1/2 inches** wide by **3-1/2 inches** high by **15-1/2 inches** long] [or] [**7-5/8 inches** wide by **3-5/8 inches** high by **15-5/8 inches** long].
- 12. Size (Actual Dimensions): 4-5/8 inches wide by 2-3/4 inches high by 9-5/8 inches long.
- 13. Application: Use where brick is exposed unless otherwise indicated.
- 14. Where shown to "**match existing**," provide hollow brick matching color range, texture, and size of existing adjacent brickwork.
- 15. Color and Texture: As selected by Architect.

2.7 MORTAR AND GROUT MATERIALS

- A. [Regional Materials: Manufacture aggregate for mortar and grout, cement, and lime within 100 miles of Project site from materials that have been extracted, harvested, or recovered, as well as manufactured, within 100 miles of Project site.

- B.]Portland Cement: ASTM C150, Type I or II, except Type III may be used for cold-weather construction. Provide natural color or white cement as required to produce mortar color indicated.
 - 1. Alkali content shall not be more than 0.1 percent when tested according to ASTM C114.
- C. Hydrated Lime: ASTM C207, Type S.
- D. Portland Cement-Lime Mix: Packaged blend of portland cement and hydrated lime containing no other ingredients.
- E. Masonry Cement: Not allowed.
- F. Mortar Cement: ASTM C1329.
 - 1. Products: Subject to compliance with requirements, provide one of the following:
 - a. Blue Circle Cement: Magnolia Superbond Mortar Cement.
 - b. Lafarge North America Inc.: Lafarge Mortar Cement.
 - c. SPEC MIX, Inc.: Mortar Cement & Sand.
- G. Self-Consolidating Grout (SCG): Fine, self-consolidating grout consisting of a dry, pre-blended grout containing Portland cement, pozzolans, performance admixtures, and fine aggregate specifically designed to be highly fluid without segregation of constituents, for completely filling cores, around heavy steel reinforcement, without need for mechanical consolidation and reconsolidation.
- H. Mortar Pigments: Natural and synthetic iron oxides and chromium oxides, compounded for use in mortar mixes and complying with ASTM C979. Use only pigments with a record of satisfactory performance in masonry mortar.
 - 1. Products: Subject to compliance with requirements, provide one of the following:
 - a. Davis Colors: True Tone Mortar Colors.
 - b. Euclid Chemical Company (The): Color-Crete Integral Color.
 - c. Solomon Colors, Inc.: SGS Concentrated A, H, and X Series Mortar Colors.
 - d. Approved substitution.
- I. Colored Cement Products: Packaged blend made from portland cement and hydrated lime and mortar pigments, all complying with specified requirements, and containing no other ingredients.
 - 1. Colored Portland Cement-Lime Mix:
 - 2. Manufacturers: Subject to compliance with requirements, provide products from one of the following:
 - 1) LafargeHolcim North America Inc.
 - 2) Lehigh Hanson; HeidelbergCement Group.
 - 3) SPEC MIX, Inc.
 - 4) Approved substitution.
 - 3. Formulate blend as required to produce color indicated or, if not indicated, as selected from manufacturer's standard colors.
 - 4. Pigments shall not exceed 10 percent of portland cement by weight.
 - 5. Pigments shall not exceed 5 percent of mortar cement by weight.
- J. Aggregate for Mortar: ASTM C144.
 - 1. For mortar that is exposed to view, use washed aggregate consisting of natural sand or crushed stone.
 - 2. For joints less than 1/4 inch thick, use aggregate graded with 100 percent passing the No. 16 sieve.
 - 3. White-Mortar Aggregates: Natural white sand or crushed white stone.
 - 4. Colored-Mortar Aggregates: Natural sand or crushed stone of color necessary to produce required mortar color.
- K. Aggregate for Grout: ASTM C404.

- L. [Epoxy Pointing Mortar: ASTM C395, epoxy-resin-based material formulated for use as pointing mortar for glazed or pre-faced masonry units (and approved for such use by manufacturer of units); in color indicated or, if not otherwise indicated, as selected by Architect from manufacturer's colors.]
- M. Cold-Weather Admixture: Nonchloride, noncorrosive, accelerating admixture complying with ASTM C494/, Type C, and recommended by manufacturer for use in masonry mortar of composition indicated.
 - 1. Products: Subject to compliance with requirements, provide one of the following:
 - a. Addiment Incorporated: Mortar Kick.
 - b. Euclid Chemical Company (The): Accelguard 80.
 - c. GCP Applied Technologies Inc.: Morset.
- N. Water-Repellent Admixture: Liquid water-repellent mortar admixture intended for use with CMUs containing integral water repellent from same manufacturer.
 - 1. Products: Subject to compliance with requirements, provide one of the following:
 - a. ACM Chemistries: RainBloc for Mortar.
 - b. GCP Applied Technologies Inc.: Dry-Block Mortar Admixture.
 - c. Master Builders Solutions by BASF: MasterPel 240MA.
 - d. SPEC MIX, Inc.: Preblended Integral Water Repellent (IWR) Masonry Mortar.
- O. Water: Potable.



2.8 REINFORCEMENT





- A. Uncoated-Steel Reinforcing Bars: ASTM A615 or ASTM A996, Grade 60.
- B. Reinforcing Bar Positioners: Wire units designed to fit into mortar bed joints spanning masonry unit cells and to hold reinforcing bars in center of cells. Units are formed from 0.148 inch steel wire, hot-dip galvanized after fabrication. Provide units designed for number of bars indicated.
 - 1. Products: Subject to compliance with requirements, provide the following:
 - a. Heckmann Building Products Inc.: #376 Rebar Positioner.
 - b. Hohmann & Barnard, Inc.: #RB or #RB-Twin Rebar Positioner.
 - c. Wire-Bond: O-Ring or Double O-Ring Rebar Positioner.
- C. Masonry Joint Reinforcement, General: ASTM A951.
 - 1. Interior Walls: Hot-dip galvanized, carbon steel.
 - 2. Exterior Walls: Stainless steel.
 - 3. Wire Size for Side Rods: 0.187 inch diameter.
 - 4. Wire Size for Cross Rods: 0.187 inch diameter.
 - 5. Wire Size for Veneer Ties: 0.187 inch diameter.
 - 6. Spacing of Cross Rods, Tabs, and Cross Ties: Not more than 16 inches on center.
 - 7. Provide in lengths of not less than 10 feet, with prefabricated corner and tee units.
- D. Masonry-Joint Reinforcement for Single-Wythe Masonry: Ladder[**or truss**] type with single pair of side rods.
 - 1. Products: Subject to compliance with requirements, provide the following:
 - a. Hohmann & Barnard, Inc.: 220 Ladder Mesh Reinforcement [**or 120 Truss-Mesh**].
 - b. Wire-Bond: Series 200 Ladder 2 Wire Mesh Reinforcement [**or Series 300 Truss 2 Wire Mesh Reinforcement**].
 - c. Approved substitution.
- E. Masonry-Joint Reinforcement for Multi-Wythe Masonry:
 - 1. **Composite Walls**: Ladder type with 1 side rod at each face shell of hollow masonry units more than 4 inches wide, plus 1 side rod [**2 side rods**]at each wythe of masonry 4 inches wide or less.
 - a. Products: Subject to compliance with requirements, provide 1 of the following:
 - 1) Hohmann & Barnard, Inc.: 240 Ladder-Twin-Mesh.

- 2) Wire-Bond: Series 300 Ladder 4 Wire Mesh Reinforcement.
 2. **Composite Walls**: Tab type, ladder[**or truss**] design, with 1 side rod at each face shell of backing wythe and with rectangular tabs sized to extend at least halfway through facing wythe but with at least 5/8 inch cover on outside face.
 - a. Products: Subject to compliance with requirements, provide 1 of the following:
 - 1) Hohmann & Barnard, Inc.: 250 Ladder Box-Mesh [**or 150 Truss Box-Mesh**].
 - 2) Wire-Bond: Series 400 Ladder Fixed Tab [**or Series 500 Truss Fixed Tab**].
 3. **Cavity Walls**: Adjustable (2-piece) type, ladder[**or truss**] design, with 1 side rod at each face shell of backing wythe and with separate adjustable ties with pintle-and-eye connections having a maximum horizontal play of 1/16 inch and maximum vertical adjustment of 1-1/4 inches. Size ties to extend at least halfway through facing wythe but with at least 5/8 inch cover on outside face.
 - a. Products: Subject to compliance with requirements, provide 1 of the following:
 - 1) Hohmann & Barnard, Inc.: 270 Ladder Eye-Wire [**or 170 Lox-All Truss Style Adjustable Joint Reinforcement**].
 - 2) Wire-Bond: Series 800 Ladder Level-Eye [**or Series 900 Truss Level-Eye**].
- F. **Horizontal Seismic Masonry** Joint Reinforcement: Adjustable (2-piece) type, ladder design, with 1 side rod at each face shell of backing wythe and with separate adjustable ties with pintle-and-eye connections having a maximum horizontal play of 1/16 inch and maximum vertical adjustment of 1-1/4 inches. Size ties to extend at least halfway through facing wythe but with at least 5/8 inch cover on outside face.
 - a. Hohmann & Barnard, Inc.: 270 S.I.S. Ladder Eye-Wire with Seismicclip Interlock System.
 - b. Wire-Bond: Series 800 Ladder Level-Eye with Plastic Seismic Clip.
2. Seismic Clip: Manufacturer's plastic seismic clip designed to engage pintle and continuous reinforcing wire.
- G. Masonry-Joint Reinforcement for Veneers Anchored with Seismic Masonry-Veneer Anchors: Single 0.187 inch diameter, stainless steel continuous wire.

2.9 TIES AND ANCHORS

- A. General: Extend ties and anchors at least 1-1/2 inches into masonry and halfway through veneer, with at least a 5/8 inch cover on outside face. Bend outer ends of wires 90 degrees and extend 2 inches parallel to face of veneer.
- B. Materials: Provide ties and anchors specified in this Article that are made from materials that comply with the following unless otherwise indicated:
 1. Hot-Dip Galvanized, Carbon-Steel Wire: ASTM A82, with ASTM A153, Class B-2 coating.
 2. Stainless Steel Wire: ASTM A580, Type 304.
 3. Galvanized-Steel Sheet: ASTM A653, Commercial Steel, G60 zinc coating.
 4. Steel Sheet, Galvanized after Fabrication: ASTM A1008, Commercial Steel, with ASTM A153, Class B coating.
 5. Stainless Steel Sheet: ASTM A240 or ASTM A666, Type 304.
 6. Steel Plates, Shapes, and Bars: ASTM A36.
 7. [**Stainless Steel Bars: ASTM A276 or ASTM A666, Type 304.**]
- C. Individual Wire Ties: Rectangular units with closed ends and not less than 4 inches wide.
 1. Z-shaped ties with ends bent 90 degrees to provide hooks not less than 2 inches long may be used for masonry constructed from solid units.
 2. Where wythes do not align or are of different materials, use adjustable ties with pintle-and-eye connections having a maximum adjustment of 1-1/4 inches.
 3. Wire: Fabricate from 3/16 inch diameter, stainless steel wire. Mill-galvanized wire ties may be used in interior walls unless otherwise indicated.

- D. Adjustable Anchors for **Connecting to Structural Steel Framing**: Provide anchors that allow vertical or horizontal adjustment but resist tension and compression forces perpendicular to plane of wall.
1. Anchor Section for Welding to Steel Frame: Crimped 1/4 inch diameter, stainless steel wire. Mill-galvanized wire may be used at interior walls unless otherwise indicated.
 2. Tie Section: Triangular-shaped wire tie made from 0.187 inch diameter, stainless steel wire. Mill-galvanized wire may be used at interior walls unless otherwise indicated.
- E. Adjustable Anchors for **Connecting to Concrete**: Provide anchors that allow vertical or horizontal adjustment but resist tension and compression forces perpendicular to plane of wall.
1. Connector Section: Dovetail tabs for inserting into dovetail slots in concrete and attached to tie section; formed from 0.109 inch thick, stainless steel sheet.
 - a. 0.108 inch thick, galvanized-steel sheet may be used at interior walls unless otherwise indicated.
 2. Tie Section: Triangular-shaped wire tie made from 0.187 inch diameter, stainless steel wire. Mill-galvanized wire may be used at interior walls unless otherwise indicated.
- F. Partition Top Anchors: 0.105 inch thick metal plate with a 3/8 inch diameter metal rod 6 inches long welded to plate and with closed-end plastic tube fitted over rod that allows rod to move in and out of tube. Fabricate from steel, hot-dip galvanized after fabrication.
- G. Rigid Anchors: Fabricate from steel bars 1-1/2 inches wide by 1/4 inch thick by 24 inches long, with ends turned up 2 inches or with cross pins unless indicated otherwise.
1. Corrosion Protection: Hot-dip galvanized to comply with ASTM A153/A153M.
- H. Adjustable Masonry-Veneer Anchors:
1. General: Provide anchors that allow vertical adjustment but resist a 100 lbf load in both tension and compression perpendicular to plane of wall without deforming or developing play in excess of 1/16 inch.
 2. Fabricate sheet metal anchor sections and other sheet metal parts from 0.109 inch thick, stainless steel sheet.
 3. Fabricate wire ties from 0.187 inch diameter, stainless steel wire unless otherwise indicated.
 4. Contractor's Option: Unless otherwise indicated, provide any of the adjustable masonry-veneer anchors specified.
 5. Screw-Attached, Masonry-Veneer Anchors:  Wire tie and a rib-stiffened sheet metal anchor section with screw holes top and bottom, projecting vertical tab having slotted hole for inserting wire tie.
 - a. Products: Subject to compliance with requirements, provide one of the following:
 - 1) FERO Corporation: Slotted Rap Tie with Lateral Tie-Clip.
 - 2) Hohmann & Barnard, Inc.: BL-407 with Byna-Lok Wire Tie.
 - 3) Wire-Bond: 2407 Adjustable Veneer Anchor with Wire-Bond Clip.
 6. Screw-Attached, Masonry-Veneer Anchors:  Wire tie and a sheet metal anchor section, 1-1/4 inches wide by 6 inches long, with screw holes top and bottom and with raised rib-stiffened strap, 5/8 by 3-5/8 inches, stamped into center to provide a slot between strap and plate for inserting wire tie.
 - a. Products: Subject to compliance with requirements, provide one of the following:
 - 1) Heckmann Building Products Inc.: #315-D Screw-On Anchor Plate with #316 Triangular Ties.
 - 2) Hohmann & Barnard, Inc.: DW-10HS.
 - 3) Wire-Bond: #1004 Type III Screw on Veneer Anchor.

7.  Screw-Attached, Masonry-Veneer Anchors: Wire tie and a gasketed sheet metal anchor section, 1-1/4 inches wide by 6 inches long, with screw holes top and bottom; top and bottom ends bent to form pronged legs of length to match thickness of insulation or sheathing; and raised rib-stiffened strap, 5/8 inch wide by 6 inches long, stamped into center to provide a slot between strap and base for inserting wire tie. Self-adhering, modified bituminous gasket fits behind anchor plate and extends beyond pronged legs.
- a. Products: Subject to compliance with requirements, provide the following:
- 1) Hohmann & Barnard, Inc.: X-Seal Anchor.
 - 2) Wire-Bond: #1004 Type III X Screw on Veneer Anchor.
8.  Seismic Masonry-Veneer Anchors: Wire tie and a sheet metal anchor section, 1-1/4 inches wide by 6 inches long, with screw holes top and bottom and with raised rib-stiffened strap, 5/8 by 3-5/8 inches, stamped into center to provide a slot between strap and plate for inserting wire tie. Connector section consists of a triangular wire tie and rigid PVC extrusion with snap-in grooves for inserting continuous wire. Connector section consists of a triangular wire tie and rigid PVC extrusion with snap-in grooves for inserting continuous wire. Fabricate wire connector sections from 0.187 inch stainless-steel wire.
- a. Products: Subject to compliance with requirements, provide one of the following:
- 1) Heckmann Building Products Inc.: #315-D with #316 Triangle Tie and #370 Seismic Hook Tab.
 - 2) Hohmann & Barnard, Inc.: DW-10HS S.I.S. Veneer Anchor.
 - 3) Wire-Bond: Type III Screw on Veneer Anchor with Metal Seismic Clip.
9.  Seismic Masonry-Veneer Anchors: Wire tie and a gasketed sheet metal anchor section, 1-1/4 inches wide by 6 inches long, with screw holes top and bottom; top and bottom ends bent to form pronged legs of length to match thickness of insulation or sheathing; and raised rib-stiffened strap, 5/8 inch wide by 6 inches long, stamped into center to provide a slot between strap and base for inserting wire tie. Self-adhering, modified bituminous gasket fits behind anchor plate and extends beyond pronged legs. Connector section consists of a triangular wire tie and rigid PVC extrusion with snap-in grooves for inserting continuous wire. Fabricate wire connector sections from 0.187 inch diameter, stainless-steel wire.
- a. Products: Subject to compliance with requirements, provide the following:
- 1) Hohmann & Barnard, Inc.: X-Seal Anchor with Seismiclip Interlock System.
 - 2) Wire-Bond: Type III X Screw on Anchor with Plastic Seismic Clip.
10.  Screw-Attached, Masonry-Veneer Anchors: Wire tie and a corrosion-resistant, self-drilling, eye-screw designed to receive wire tie. Eye-screw has spacer that seats directly against framing and is same thickness as sheathing and has gasketed washer head that covers hole in sheathing.
- a. Products: Subject to compliance with requirements, provide one of the following:
- 1) Heckmann Building Products Inc.: #75 TC Pos-I-Tie Thermal Clip.
 - 2) Hohmann & Barnard, Inc.: Thermal 2-Seal Wing Nut Anchor.
 - 3) Wire-Bond: Sure Tie Anchoring System.
- b. Provide manufacturer's appropriate anchors for specific wall construction indicated on Drawing.
- c. For use at brick veneer with insulation.
11. Polymer-Coated, Steel Drill Screws for Steel Studs: ASTM C954 except manufactured with hex washer head and neoprene washer, No. 10 diameter by length required to penetrate steel stud flange with not less than 3 exposed threads, and with organic polymer coating with salt-spray resistance to red rust of more than 800 hours per ASTM B117.

- a. Products: Subject to compliance with requirements, provide one of the following:
 - 1) ITW Buildex: Teks Maxiseal with Climaseal finish.
 - 2) Textron Inc.: Textron Fastening Systems; Elco Dril-Flex with Stalgard finish.
12. Stainless-Steel Drill Screws for Steel Studs: Fasteners made from Type 410 stainless steel or made with a carbon-steel drill point and 300 Series stainless-steel shank, complying with ASTM C954 except manufactured with hex washer head and neoprene or EPDM washer, No. 10 diameter by length required to penetrate steel stud flange with not less than 3 exposed threads.
 - a. Products: Subject to compliance with requirements, provide the following:
 - 1) ITW Buildex: Scots long life Teks.
 - 2) Wire-Bond: SFS Stadler SX Fastener.

- I.  Joint Stabilizing Anchors: Galvanized 1/32 inch sheet steel joint stabilization anchors with two 0.168 inch thick galvanized steel wires for maintaining alignment of joints. Designed to be field-bendable to accommodate horizontal to vertical transitions.
 1. Products: Subject to compliance with requirements, provide the following:
 - a. Heckmann Building Products Inc.: #353 Debinded Shear Anchor.
 - b. Hohmann & Barnard, Inc.: Slip-Set Stabilizer.
 - c. Wire-Bond: Control Joint Anchor #1700.

2.10 EMBEDDED FLASHING MATERIALS

- A. Metal Flashing: Provide metal flashing complying with SMACNA's "Architectural Sheet Metal Manual," Section 076200 – Sheet Metal Flashing and Trim, and as follows:
 1. Stainless Steel: ASTM A240 or ASTM A666, Type 304, 0.0239 inch thick; solder metal flashing at corners.
 2. Fabricate continuous flashings in sections 96 inches long minimum, but not exceeding 12 feet. Provide splice plates at joints of formed, smooth metal flashing.
 3. Fabricate through-wall flashing with drip edge, unless otherwise indicated. Fabricate by extending flashing 1/2 inch out from wall, with outer edge bent down 30 degrees and hemmed.
 4. Fabricate metal sealant stop from stainless steel. Extend at least 3 inches into wall and out to exterior face of wall. At exterior face of wall, bend metal back on itself for 3/4 inch and down into joint 3/8 inch to form a stop for retaining sealant backer rod.
 5. Locations: Where flashing is exposed to view and the following:
 - a. Where flashing is indicated to receive counterflashing, use metal flashing.
 - b. Where flashing is indicated to be turned down at or beyond wall face, use metal flashing.
 - c. Where flashing is partly exposed and is indicated to terminate at wall face, use metal flashing with a sealant stop with a drip edge.
- B. Flexible Flashing: Use the following unless otherwise indicated:
 1. Copper-Laminated Flashing: 5 oz./sq. ft. copper sheet bonded between 2 layers of glass-fiber cloth.
 - a. Products: Subject to compliance with requirements, provide 1 of the following:
 - 1) Advanced Building Products Inc.: Copper Sealtite 2000.
 - 2) Hohmann & Barnard, Inc.: H & B C-Fab Flashing.
 - 3) Wire-Bond, Inc.: Copper Seal Flashing.
 - 4) York Manufacturing, Inc.: Multi-Flash 500.
 - 5)
 - b. Locations: Where flashing is fully concealed from view.
 2. Rubberized-Asphalt Flashing: Composite flashing product consisting of a pliable, adhesive rubberized-asphalt compound, bonded to a high-density, cross-laminated polyethylene film.
 - a. Products: Subject to compliance with requirements, provide 1 of the following:
 - 1) Advanced Building Products Inc.: Peel-N-Seal.
 - 2) Carlisle Coatings & Waterproofing: CCW-705-TWF Thru-Wall Flashing.

- 3) Fiberweb—Clark Hammerbeam Corp.: Aquaflash 500.
 - 4) GCP Applied Technologies Inc.: [**Perm-A-Barrier Wall Flashing**][**Vycor V40 Self-Adhered Flashing**].
 - 5) Henry Company: Blueskin SA or Fortiflash 40.
 - 6) Polyguard Products, Inc.: Polyguard 400 [**Polyguard 300**].
 - 7) Tremco, Inc.: ExoAir TWF.
 - 8) W. R. Meadows, Inc.: Air-Shield Thru-Wall Flashing.
 - 9) York Manufacturing, Inc.: York Seal Flashing.
 - b. Overall Thickness: Not less than 40 mils (0.040 inch).
 - c. Locations: Where flashing is partly exposed, copper flashing cannot be used, and where indicated.
 - d. Accessories: Provide preformed corners, end dams, other special shapes, and seaming materials produced by flashing manufacturer.
3. Butyl Rubber Flashing: Composite, self-adhesive, flashing product consisting of a pliable, butyl rubber compound, bonded to a high-density polyethylene film, aluminum foil, or spunbonded polyolefin.
- a. Products: Subject to compliance with requirements, provide one of the following:
 - 1) DuPont: DuPont StraightFlash.
 - 2) GCP Applied Technologies Inc.: Vycor Pro.
 - 3) Protecto Wrap Company: BT-25 XL.
 - 4) Raven Industries, Inc.: Fortress Flashshield.
 - b. Overall Thickness: Not less than 0.040 inch/40 mils.
 - c. Locations: Where flashing is partly exposed and will not come in contact with asphalt, copper flashing cannot be used, and where indicated.
 - d. Accessories: Provide preformed corners, end dams, other special shapes, and seaming materials produced by flashing manufacturer.
- C. Single-Wythe CMU Flashing System: System of CMU cell flashing pans and interlocking CMU web covers made from UV-resistant, high-density polyethylene. Cell flashing pans have integral weep spouts designed to be built into mortar bed joints and that extend into the cell to prevent clogging with mortar.
1. Products: Subject to compliance with requirements, provide 1 of the following:
 - a. Mortar Net Solutions; Blok-Flash.
 - b. Approved substitution.
- D. Solder and Sealants for Sheet Metal Flashings: As specified in Section 076200 – Sheet Metal Flashing and Trim.
- E. Adhesives, Primers, and Seam Tapes for Flashings: Flashing manufacturer's standard products or products recommended by flashing manufacturer for bonding flashing sheets to each other and to substrates.
- F. Termination Bars for Flexible Flashing: Stainless steel sheet 0.019 inch by 1-1/2 inches with a 3/8 inch sealant flange at top.
- 2.11 MISCELLANEOUS MASONRY ACCESSORIES
- A. Compressible Filler: Premolded filler strips complying with ASTM D1056, Grade 2A1; compressible up to 35 percent; of width and thickness indicated; formulated from neoprene or urethane.
1. Products: Subject to compliance with requirements, provide the following:
 - a. Hohmann & Barnard, Inc.: #NS – Closed Cell Neoprene Sponge.
 - b. NMW, Inc.: Foamtech N.
 - c. Williams Products, Inc.: Everlastic EVA-200G.
 - d. Wire-Bond: Expansion Joint.

- B. Preformed Control-Joint Gaskets: Made from styrene-butadiene-rubber compound, complying with ASTM D2000, Designation M2AA-805 and designed to fit standard sash block and to maintain lateral stability in masonry wall; size and configuration as indicated.
- C. Bond-Breaker Strips: Asphalt-saturated, organic roofing felt complying with ASTM D226, Type I (No. 15 asphalt felt).
- D. Weep/Cavity Vent Products: Use one of the following unless otherwise indicated:
 - 1. **Wicking Material:** Absorbent rope, made from cotton or UV-resistant synthetic fiber, 3/8 inch in diameter, in length required to produce minimum of 1 inch exposure on exterior and 18 inches in cavity between wythes. Use only for weeps.
 - 2. **Cellular Plastic Vents:** 1-piece, flexible extrusion made from UV-resistant polypropylene copolymer, full height and width of head joint and depth 1/8 inch less than depth of outer wythe, in color selected from manufacturer's standard.
 - a. Products: Subject to compliance with requirements, provide 1 of the following:
 - 1) Advanced Building Products Inc.: Mortar Maze Cell Vent.
 - 2) Heckmann Building Products Inc.: No. 85 Cell Vent.
 - 3) Hohmann & Barnard, Inc.: Quadro-Vent.
 - 4) Mortar Net Solutions: CellVent.
 - 5) Wire-Bond: Cell Vent.
- E. Cavity Drainage Material: Free-draining mesh, made from polymer strands that will not degrade within the wall cavity.
 - 1. Products: Subject to compliance with requirements, provide 1 one of the following:
 - a. Advanced Building Products Inc.: Mortar Break DT.
 - b. Hohmann & Barnard, Inc.: Mortar Trap.
 - c. Masonpro, Inc.: ProNet DT.
 - d. Mortar Net Solutions: Mortar Net with Insect Barrier or WallDefender.
 - e. Wire-Bond: Cavity Net DT.
 - 2. Configuration: Provide one of the following:
 - a. Strips, full-depth of cavity and 10 inches wide, with dovetail shaped notches approximately 7 inches deep that prevent clogging with mortar droppings.

2.12 MASONRY CLEANERS

- A. Proprietary Acidic Cleaner – Concrete Masonry Units: Manufacturer's standard-strength, general purpose cleaner designed for removing mortar/grout stains from new masonry without damaging masonry. Use product approved for intended use by cleaner manufacturer and manufacturer of masonry units being cleaned.
 - 1. Products: Subject to compliance with requirements, provide one of the following:
 - a. Diedrich Technologies, Inc.; a division of Hohmann & Barnard, Inc.: 202 New Masonry Detergent.
 - b. EaCo Chem, Inc.: NMD 80.
 - c. ProSoCo, Inc.: Sure Klean 600.
- B. Proprietary Acidic Cleaner – Ground Finish Concrete Masonry Units: Manufacturer's standard-strength, general-purpose, nonetching acidic cleaner for removing common construction and atmospheric staining, rust, mud, oil, and mortar smears from custom masonry and other architectural concrete surfaces, and adds depth to colors and brightens white matrices and exposed aggregate.
 - 1. Products: Subject to compliance with requirements, provide one of the following:
 - a. Diedrich Technologies, Inc.; a division of Hohmann & Barnard, Inc.: 222 Non-Etching Concrete Brick & Burnished Masonry Cleanser.
 - b. EaCo Chem, Inc.: NMD 80.
 - c. ProSoCo, Inc.: Sure Klean Burnished Custom Masonry Cleaner.

2.13 MORTAR AND GROUT MIXES

- A. General: Do not use admixtures, including pigments, air-entraining agents, accelerators, retarders, water-repellent agents, antifreeze compounds, or other admixtures unless otherwise indicated.
1. Do not use calcium chloride in mortar or grout.
 2. Use portland cement-lime **[or] [mortar cement]** mortar unless otherwise indicated.
 3. For exterior masonry, use portland cement-lime **[or] [mortar cement]** mortar mortar.
 4. For reinforced masonry, use portland cement-lime **[or] [mortar cement]** mortar mortar.
 5. Add cold-weather admixture (if used) at same rate for mortar that will be exposed to view, regardless of weather conditions, to ensure that mortar color is consistent.
- B. Mortar for Unit Masonry: Comply with ASTM C270, Proportion Specification. Provide the following types of mortar for applications stated unless another type is indicated or needed to provide required compressive strength of masonry.
1. Type M: 2,500 psi; for masonry in contact with earth and walls below grade.
 2. Type S: 1,800 psi; for exterior, above-grade, load-bearing and non-load-bearing walls[, **brick veneer,**][**stone veneer,**] and parapet walls and for other applications where another type is not indicated.
 3. Type N: 750 psi; for interior non-load-bearing walls. Type O may be used instead of Type N.
- C. Mortar Material: Type S, mixed using a solution of 5 parts water and 1 part manufacturer's latex acrylic additive.
- D. Pigmented Mortar: Use colored cement product or select and proportion pigments with other ingredients to produce color required. Do not add pigments to colored cement products.
1. Pigments shall not exceed 10 percent of portland cement by weight.
 2. Pigments shall not exceed 5 percent of **[masonry cement] [or] [mortar cement]** by weight.
 3. Mix to match Architect's sample.
 4. Application: Use pigmented mortar for exposed mortar joints with the following units:
 - a. Decorative CMUs.
 - b. Face brick.
 - c. **[Glazed brick.**
 - d. **][Glazed structural clay facing tile.**
 - e. **][Stone trim units.**
 - f. **][Cast-stone trim units.]**
- E. Colored-Aggregate Mortar: Produce required mortar color by using colored aggregates and natural color or white cement as necessary to produce required mortar color.
1. Mix to match Architect's sample.
 2. Application: Use colored-aggregate mortar for exposed mortar joints with the following units:
 - a. Decorative CMUs.
 - b. Face brick.
 - c. **[Glazed brick.**
 - d. **][Glazed structural clay facing tile.**
 - e. **][Stone trim units.**
 - f. **][Cast-stone trim units.]**
- F. Grout for Unit Masonry: Comply with ASTM C476.
1. Use grout of type indicated or, if not otherwise indicated, of type (fine or coarse) that will comply with TMS 602 for dimensions of grout spaces and pour height.
 2. Proportion grout in accordance with ASTM C476, **[Table 1] [or] [paragraph 4.2.2 for specified 28-day compressive strength indicated, but not less than 2000 psi]**.
 3. Provide grout with a slump of **[8 to 11 inches] [10 to 11 inches]** as measured according to ASTM C143.
- G. Epoxy Pointing Mortar: Mix epoxy pointing mortar to comply with mortar manufacturer's written instructions.

1. Application: Use epoxy pointing mortar for exposed mortar joints with the following units:
 - a. Pre-faced CMUs.
 - b. Glazed brick.
 - c. Glazed structural clay facing tile.

PART 3 - EXECUTION

3.1 EXAMINATION

- A. Examine conditions, with Installer present, for compliance with requirements for installation tolerances and other conditions affecting performance of Work.
 1. For the record, prepare written report, endorsed by Installer, listing conditions detrimental to performance of Work.
 2. Verify that foundations are within tolerances specified.
 3. Verify that reinforcing dowels are properly placed.
 4. Verify that substrates are free of substances that impair mortar bond.
- B. Before installation, examine rough-in and built-in construction for piping systems to verify actual locations of piping connections.
- C. Proceed with installation only after unsatisfactory conditions have been corrected.

3.2 INSTALLATION, GENERAL

- A. Thickness: Build cavity **[and]** **[composite]** walls and other masonry construction to full thickness shown. Build single-wythe walls to actual widths of masonry units, using units of widths indicated.
- B. Build chases and recesses to accommodate items specified in this and other Sections.
- C. Leave openings for equipment to be installed before completing masonry. After installing equipment, complete masonry to match construction immediately adjacent to opening.
- D. Use full-size units without cutting if possible. If cutting is required to provide a continuous pattern or to fit adjoining construction, cut units with motor-driven saws; provide clean, sharp, unchipped edges. Allow units to dry before laying unless wetting of units is specified. Install cut units with cut surfaces and, where possible, cut edges concealed.
- E. Select and arrange units for exposed unit masonry to produce a uniform blend of colors and textures. Mix units from several pallets or cubes as they are placed.
- F. [Matching Existing Masonry: Match coursing, bonding, color, and texture of existing masonry.]
- G. Wetting of Brick: Wet brick before laying if initial rate of absorption exceeds 30 g/30 sq. in. per minute when tested according to ASTM C67. Allow units to absorb water so they are damp but not wet at time of laying.

3.3 TOLERANCES

- A. Dimensions and Locations of Elements:
 1. For dimensions in cross section or elevation, do not vary by more than plus 1/2 inch or minus 1/4 inch.
 2. For location of elements in plan, do not vary from that indicated by more than plus or minus 1/2 inch.
 3. For location of elements in elevation, do not vary from that indicated by more than plus or minus 1/4 inch in a story height or 1/2 inch total.
- B. Lines and Levels:

1. For bed joints and top surfaces of bearing walls, do not vary from level by more than 1/4 inch in 10 feet, or 1/2-inch maximum.
 2. For conspicuous horizontal lines, such as lintels, sills, parapets, and reveals, do not vary from level by more than 1/8 inch in 10 feet, 1/4 inch in 20 feet, or 1/2 inch maximum.
 3. For vertical lines and surfaces, do not vary from plumb by more than 1/4 inch in 10 feet, 3/8 inch in 20 feet, or 1/2 inch maximum.
 4. For conspicuous vertical lines, such as external corners, door jambs, reveals, and expansion and control joints, do not vary from plumb by more than 1/8 inch in 10 feet, 1/4 inch in 20 feet, or 1/2 inch maximum.
 5. For lines and surfaces, do not vary from straight by more than 1/4 inch in 10 feet, 3/8 inch in 20 feet, or 1/2 inch maximum.
 6. For vertical alignment of exposed head joints, do not vary from plumb by more than 1/4 inch in 10 feet or 1/2 inch maximum.
 7. For faces of adjacent exposed masonry units, do not vary from flush alignment by more than 1/16 inch except due to warpage of masonry units within tolerances specified for warpage of units.
- C. Joints:
1. For bed joints, do not vary from thickness indicated by more than plus or minus 1/8 inch, with a maximum thickness limited to 1/2 inch.
 2. For exposed bed joints, do not vary from bed-joint thickness of adjacent courses by more than 1/8 inch.
 3. For head and collar joints, do not vary from thickness indicated by more than plus 3/8 inch or minus 1/4 inch.
 4. For exposed head joints, do not vary from thickness indicated by more than plus or minus 1/8 inch. Do not vary from adjacent bed-joint and head-joint thicknesses by more than 1/8 inch.
 5. For exposed bed joints and head joints of stacked bond, do not vary from a straight line by more than 1/16 inch from one masonry unit to the next.

3.4 LAYING MASONRY WALLS

- A. Lay out walls in advance for accurate spacing of surface bond patterns with uniform joint thicknesses and for accurate location of openings, movement-type joints, returns, and offsets. Avoid using less-than-half-size units, particularly at corners, jambs, and, where possible, at other locations.
- B. Bond Pattern for Exposed Masonry: Unless otherwise indicated, lay exposed masonry in running bond **[stack bond] [1/3 running bond] [Flemish bond] [English bond] [bond pattern indicated on Drawings]**. Do not use units with less-than-nominal 4 inch horizontal face dimensions at corners or jambs.
- C. Lay concealed masonry with all units in a wythe in running bond or bonded by lapping not less than 2 inches **[4 inches]**. Bond and interlock each course of each wythe at corners. Do not use units with less-than-nominal 4 inch horizontal face dimensions at corners or jambs.
- D. Sound Absorbing CMU: Lay units in running bond or stack bond as specified with closed tops up and in a full horizontal bed of mortar. Lay units with slots facing toward room or area where sound absorption is required as indicated on Drawings. Keep slots free of mortar and debris. Keep exposed mortar at bottom of each slot neatly tooled. Do not use rake type joints.
- E. Stopping and Resuming Work: Stop Work by stepping back units in each course from those in course below; do not tooth. When resuming Work, clean masonry surfaces that are to receive mortar, remove loose masonry units and mortar, **[and wet brick]** if required before laying fresh masonry.
- F. Built-in Work: As construction progresses, build in items specified in this and other Sections. Fill in solidly with masonry around built-in items.

- G. Where built-in items are to be embedded in cores of hollow masonry units, place a layer of metal lath, wire mesh, or plastic mesh in the joint below, and rod mortar or grout into core.
- H. Fill cores in hollow CMUs with grout 24 inches under bearing plates, beams, lintels, posts, and similar items unless indicated otherwise.
- I. Build nonload-bearing interior partitions full height of story to underside of solid floor or roof structure above unless indicated otherwise.
 - 1. Install compressible filler in joint between top of partition and underside of structure above.
 - 2. Fasten partition top anchors to structure above and build into top of partition. Grout cells of CMUs solidly around plastic tubes of anchors and push tubes down into grout to provide 1/2 inch clearance between end of anchor rod and end of tube. Space anchors 48 inches on center unless otherwise indicated.
 - 3. Wedge nonload-bearing partitions against structure above with small pieces of tile, slate, or metal. Fill joint with mortar after dead-load deflection of structure above approaches final position.
 - 4. At fire-rated partitions, treat joint between top of partition and underside of structure above to comply with Section 078443 – Joint Firestopping.

3.5 MORTAR BEDDING AND JOINTING

- A. Lay **[face brick]** and CMUs as follows:
 - 1. Bed face shells in mortar and make head joints of depth equal to bed joints.
 - 2. Bed webs in mortar in all courses of piers, columns, and pilasters.
 - 3. Bed webs in mortar in grouted masonry, including starting course on footings.
 - 4. Fully bed entire units, including areas under cells, at starting course on footings where cells are not grouted.
 - 5. Fully bed units and fill cells with mortar at anchors and ties as needed to fully embed anchors and ties in mortar.
- B. Lay solid masonry units **[and hollow brick]** with completely filled bed and head joints; butter ends with sufficient mortar to fill head joints and shove into place. Do not deeply furrow bed joints or slush head joints.
- C. Set **[stone] [cast-stone]** trim units in full bed of mortar with full vertical joints. Fill dowel, anchor, and similar holes.
 - 1. Clean soiled surfaces with fiber brush and soap powder and rinse thoroughly with clear water.
 - 2. Allow cleaned surfaces to dry before setting.
 - 3. Wet joint surfaces thoroughly before applying mortar.
 - 4. Rake out mortar joints for pointing with sealant.
- D. [Lay structural clay tile as follows:]
 - 1. **[Lay vertical-cell units with full head joints unless otherwise indicated. Provide bed joints with full mortar coverage on face shells and webs.]**
 - 2. **][Lay horizontal-cell units with full bed joints unless otherwise indicated. Keep drainage channels, if any, free of mortar. Form head joints with sufficient mortar so excess will be squeezed out as units are placed in position. Butter both sides of units to be placed, or butter 1 side of unit already in place and 1 side of unit to be placed.]**
 - 3. **][Maintain joint thicknesses indicated except for minor variations required to maintain bond alignment. If not indicated, lay walls with 1/4- to 3/8-inch-thick joints.]**
- E. Tool exposed joints slightly concave when thumbprint hard, using a jointer larger than joint thickness unless otherwise indicated.
 - 1. For glazed masonry units, use a nonmetallic jointer 3/4 inch or more in width.
- F. Cut joints flush for masonry walls to receive plaster or other direct-applied finishes (other than paint) unless otherwise indicated.

- G. Cut joints flush where indicated to receive waterproofing, cavity wall insulation, and air barriers unless otherwise indicated.

3.6 COMPOSITE MASONRY

- A. Bond wythes of composite masonry together using one of the following methods:
 - 1. Individual Metal Ties: Provide ties as shown installed in horizontal joints, but not less than 1 metal tie for 2.67 square feet of wall area spaced not to exceed 24 inches on center horizontally and 16 inches on center vertically. Stagger ties in alternate courses. Provide additional ties within 12 inches of openings and space not more than 36 inches apart around perimeter of openings. At intersecting and abutting walls, provide ties at no more than 24 inches on center vertically.
 - 2. Masonry Joint Reinforcement: Installed in horizontal mortar joints.
 - a. Where bed joints of both wythes align, use ladder-type reinforcement extending across both wythes.
 - b. Where bed joints of wythes do not align, use adjustable (2-piece) type reinforcement with continuous horizontal wire in facing wythe attached to ties.
 - 3. Header Bonding: Provide masonry unit headers extending not less than 3 inches into each wythe. Space headers not more than 8 inches clear horizontally and 16 inches clear vertically.
- B. Collar Joints: Solidly fill collar joints by parging face of first wythe that is laid and shoving units of other wythe into place.
- C. Corners: Provide interlocking masonry unit bond in each wythe and course at corners unless otherwise indicated.
 - 1. Provide continuity with masonry-joint reinforcement at corners by using prefabricated L-shaped units as well as masonry bonding.
- D. Intersecting and Abutting Walls: Unless vertical expansion or control joints are shown at juncture, bond walls together as follows:
 - 1. Provide individual metal ties not more than 8 inches on center.
 - 2. Provide continuity with masonry-joint reinforcement by using prefabricated T-shaped units.
 - 3. Provide rigid metal anchors not more than 24 inches on center. If used with hollow masonry units, embed ends in mortar-filled cores.

3.7 CAVITY WALLS

- A. Bond wythes of cavity walls together using one of the following methods:
 - 1. Individual Metal Ties: Provide ties as shown installed in horizontal joints, but not less than 1 metal tie for 2.67 square feet of wall area spaced not to exceed 24 inches on center horizontally and 16 inches on center vertically. Stagger ties in alternate courses. Provide additional ties within 12 inches of openings and space not more than 36 inches apart around perimeter of openings. At intersecting and abutting walls, provide ties at no more than 24 inches on center vertically.
 - a. Where bed joints of wythes do not align, use adjustable (2-piece) type ties.
 - b. Where one wythe is of clay masonry and the other of concrete masonry, use adjustable (2-piece) type ties to allow for differential movement regardless of whether bed joints align.
 - 2. Masonry-Joint Reinforcement: Installed in horizontal mortar joints.
 - a. Where bed joints of both wythes align, use ladder-type reinforcement extending across both wythes.
 - b. Where bed joints of wythes do not align, use adjustable (2-piece) type reinforcement with continuous horizontal wire in facing wythe attached to ties.
 - c. Where one wythe is of clay masonry and the other of concrete masonry, use adjustable (2-piece) type reinforcement with continuous horizontal wire in facing wythe attached to ties to allow for differential movement regardless of whether bed joints align.

3. Header Bonding: Provide masonry unit headers extending not less than 3 inches into each wythe. Space headers not more than 8 inches clear horizontally and 16 inches clear vertically.
 4. Masonry-Veneer Anchors: Comply with requirements for anchoring masonry veneers.
- B. Bond wythes of cavity walls together using bonding system indicated on Drawings.
- C. Keep cavities clean of mortar droppings and other materials during construction. Bevel beds away from cavity, to minimize mortar protrusions into cavity. Do not attempt to trowel or remove mortar fins protruding into cavity.
- D. Parge cavity face of backup wythe in a single coat approximately 3/8 inch thick. Trowel face of parge coat smooth.
- E. Installing Cavity Wall Insulation: Place small dabs of adhesive, spaced approximately 12 inches on center both ways, on inside face of insulation boards, or attach with plastic fasteners designed for this purpose. Fit courses of insulation between wall ties and other confining obstructions in cavity, with edges butted tightly both ways. Press units firmly against inside wythe of masonry or other construction as shown.
1. Fill cracks and open gaps in insulation with crack sealer compatible with insulation and masonry.

3.8 ANCHORED MASONRY VENEERS

- A. Anchor masonry veneers to wall framing and concrete and masonry backup with seismic masonry-veneer anchors to comply with the following requirements:
1. Fasten screw-attached and seismic anchors through sheathing to wall framing and to **[concrete] [and]** masonry backup with metal fasteners of type indicated. Use 2 fasteners unless anchor design only uses one fastener.
 2. Embed **[tie sections]** connector sections and continuous wire in masonry joints.
 3. Locate anchor sections to allow maximum vertical differential movement of ties up and down.
 4. Space anchors as indicated, but not more than 18 inches on center vertically and 24 inches on center horizontally, with not less than one anchor for each 2 sq. ft. of wall area. Install additional anchors within 12 inches of openings and at intervals, not exceeding 8 inches, around perimeter.
 5. Space anchors as indicated, but not more than 16 inches on center vertically and 25 inches on center horizontally, with not less than one anchor for each 2.67 sq. ft. **[3.5 sq. ft.]** of wall area. Install additional anchors within 12 inches of openings and at intervals, not exceeding 36 inches, around perimeter.
 6. Space anchors as indicated, but not more than 18 inches on center vertically and horizontally. Install additional anchors within 12 inches of openings and at intervals, not exceeding 24 inches, around perimeter.
- B. Provide not less than 2 inches of airspace between back of masonry veneer and face of sheathing or insulation.
1. Keep airspace clean of mortar droppings and other materials during construction. Bevel beds away from airspace, to minimize mortar protrusions into airspace. Do not attempt to trowel or remove mortar fins protruding into airspace.

3.9 MASONRY-JOINT REINFORCEMENT

- A. General: Install entire length of longitudinal side rods in mortar with a minimum cover of 5/8 inch on exterior side of walls, 1/2 inch elsewhere. Lap reinforcement a minimum of 6 inches.
1. Space reinforcement not more than 16 inches on center.
 2. Space reinforcement not more than 8 inches on center in foundation walls and parapet walls.
 3. Provide reinforcement not more than 8 inches above and below wall openings and extending 12 inches beyond openings in addition to continuous reinforcement.

- B. Interrupt joint reinforcement at control and expansion joints unless otherwise indicated.
- C. Provide continuity at wall intersections by using prefabricated T-shaped units.
- D. Provide continuity at corners by using prefabricated L-shaped units.
- E. Cut and bend reinforcing units as directed by manufacturer for continuity at corners, returns, offsets, column fireproofing, pipe enclosures, and other special conditions.

3.10 ANCHORING MASONRY TO STRUCTURAL STEEL **[AND] [CONCRETE]**

- A. Anchor masonry to structural steel **[and] [concrete]**, where masonry abuts or faces structural steel or concrete, to comply with the following:
 - 1. Provide an open space not less than 1 inch wide between masonry and structural steel **[or] [concrete]** unless otherwise indicated. Keep open space free of mortar and other rigid materials.
 - 2. Anchor masonry with anchors embedded in masonry joints and attached to structure.
 - 3. Space anchors as indicated, but not more than 24 inches on center vertically and 36 inches on center horizontally.

3.11 CONTROL AND EXPANSION JOINTS

- A. General: Install control- and expansion-joint materials in unit masonry as masonry progresses. Do not allow materials to span control and expansion joints without provision to allow for in-plane wall or partition movement.
- B. Form control joints in concrete masonry using one of the following methods:
 - 1. Fit bond-breaker strips into hollow contour in ends of CMUs on one side of control joint. Fill resultant core with grout, and rake out joints in exposed faces for application of sealant.
 - 2. Install preformed control-joint gaskets designed to fit standard sash block.
 - 3. Install temporary foam-plastic filler in head joints, and remove filler when unit masonry is complete for application of sealant.
- C. [Form expansion joints in brick as follows:]
 - 1. Build flanges of metal expansion strips into masonry. Lap each joint 4 inches in direction of water flow. Seal joints below grade and at junctures with horizontal expansion joints if any.
 - 2. Build flanges of **factory-fabricated**, expansion-joint units into masonry.
 - 3. Build in compressible joint fillers where indicated.
 - 4. Form open joint full depth of brick wythe and of width indicated, but not less than 3/8 inch for installation of sealant and backer rod specified in Section 079200 – Joint Sealants.
- D. Provide horizontal, pressure-relieving joints by either leaving an airspace or inserting a compressible filler of width required for installing sealant and backer rod specified in Section 079200 – Joint Seals, but not less than 3/8 inch.
 - 1. Locate horizontal, pressure-relieving joints beneath shelf angles supporting masonry.

3.12 LINTELS

- A. Install steel lintels where indicated on structural Drawings. Provide minimum bearing of 8 inches at each jamb unless otherwise indicated.
- B. Provide minimum bearing of 8 inches at each jamb unless otherwise indicated.

3.13 FLASHING, WEEP HOLES, AND CAVITY VENTS

- A. General: Install embedded flashing and weep holes in masonry at shelf angles, lintels, ledges, other obstructions to downward flow of water in wall, and where indicated. Install cavity vents at shelf angles, ledges, and other obstructions to upward flow of air in cavities, and where indicated.

- B. Install flashing as follows unless otherwise indicated:
1. Prepare masonry surfaces so they are smooth and free from projections that could puncture flashing. Where flashing is within mortar joint, place through-wall flashing on sloping bed of mortar and cover with mortar. Before covering with mortar, seal penetrations in flashing with adhesive, sealant, or tape as recommended by flashing manufacturer.
 2. At multiwythe masonry walls, including cavity walls, extend flashing through outer wythe, turned up a minimum of 8 inches, and through inner wythe to within 1/2 inch of interior face of wall in exposed masonry. Where interior face of wall is to receive furring or framing, carry flashing completely through inner wythe and turn flashing up approximately 2 inches on interior face.
 3. At masonry-veneer walls, extend flashing through veneer, across airspace behind veneer, and up face of sheathing at least 8 inches; with upper edge tucked under water-resistive barrier air or barrier, lapping at least 4 inches. Fasten upper edge of flexible flashing to sheathing through termination bar.
 4. At lintels and shelf angles, extend flashing a minimum of 6 inches into masonry at each end. At heads and sills, extend flashing 6 inches at ends and turn up not less than 4 inches to form end dams.
 5. Install metal drip edges beneath flexible flashing at exterior face of wall. Stop flexible flashing 1/2 inch back from outside face of wall, and adhere flexible flashing to top of metal drip edge.
 6. Install metal flashing termination beneath flexible flashing at exterior face of wall. Stop flexible flashing 1/2 inch back from outside face of wall, and adhere flexible flashing to top of metal flashing termination.
 7. Cut flexible flashing off flush with face of wall after masonry wall construction is completed.
- C. Install single-wythe CMU flashing system in bed joints of CMU walls where indicated to comply with manufacturer's written instructions. Install CMU cell pans with upturned edges located below face shells and webs of CMUs above and with weep spouts aligned with face of wall. Install CMU web covers so that they cover upturned edges of CMU cell pans at CMU webs and extend from face shell to face shell.
- D. Install reglets and nailers for flashing and other related construction where they are shown to be built into masonry.
- E. Install weep holes in exterior wythes and veneers in head joints of first course of masonry immediately above embedded flashing.
1. Use **[specified weep/cavity vent products]** **[or]** **[open-head joints]** to form weep holes.
 2. Use wicking material to form weep holes above flashing under brick sills. Turn wicking down at lip of sill to be as inconspicuous as possible.
 3. Space weep holes 24 inches on center unless otherwise indicated.
 4. Space weep holes formed from **[plastic tubing]** **[or]** **[wicking material]** 16 inches on center.
 5. Cover cavity side of weep holes with plastic insect screening at cavities insulated with loose-fill insulation.
 6. Trim wicking material flush with outside face of wall after mortar has set.
- F. Place pea gravel in cavities as soon as practical to a height equal to height of first course above top of flashing, but not less than 2 inches, to maintain drainage.
1. Fill cavities full height by placing pea gravel in cavities as masonry is laid, so that at any point, masonry does not extend more than 24 inches above top of pea gravel.
- G. Place cavity drainage material in cavities and airspace behind veneers to comply with configuration requirements for cavity drainage material in "Miscellaneous Masonry Accessories" Article.
- H. Weeps/Vents: Use specified wicking material and plastic vents to form weep holes as follows:
1. Locations: Exterior wythes of first course of masonry immediately above embedded flashing.
 2. Wicking Material:
 - a. Form weep holes above flashing under brick sills spaced 16 inches on center.

- b. Turn wicking down at lip of sill to be as inconspicuous as possible.
- c. Trim wicking material flush with outside face of wall after mortar has set.
- 3. Plastic Vents:
 - a. Embed in head joints according to manufacturer's requirements.
 - b. Space at 16 inches on center.

3.14 INSTALLATION OF REINFORCED UNIT MASONRY

- A. Temporary Formwork and Shores: Construct formwork and shores as needed to support reinforced masonry elements during construction.
 - 1. Construct formwork to provide shape, line, and dimensions of completed masonry as indicated. Make forms sufficiently tight to prevent leakage of mortar and grout. Brace, tie, and support forms to maintain position and shape during construction and curing of reinforced masonry.
 - 2. Do not remove forms and shores until reinforced masonry members have hardened sufficiently to carry their own weight and that of other loads that may be placed on them during construction.
- B. Placing Reinforcement: Comply with requirements in TMS 602.
- C. Grouting: Do not place grout until entire height of masonry to be grouted has attained enough strength to resist grout pressure.
 - 1. Comply with requirements in TMS 602 for cleanouts and for grout placement, including minimum grout space and maximum pour height.
 - 2. Limit height of vertical grout pours to not more than 60 inches.

3.15 FIELD QUALITY CONTROL

- A. Testing and Inspecting: Owner will engage special inspectors to perform tests and inspections and prepare reports. Allow inspectors access to scaffolding and work areas as needed to perform tests and inspections. Retesting of materials that fail to comply with specified requirements shall be done at Contractor's expense.
- B. Inspections: Special inspections according to Level **[B]** **[and]** C in TMS 402, Section 3.1.3 Quality Assurance and Table 3.1.3 – Level C Quality Assurance.
 - 1. Provide continuous and periodic inspections according to TMS 402.
 - 2. Begin masonry construction only after inspectors have verified proportions of site-prepared mortar.
 - 3. Place grout only after inspectors have verified compliance of grout spaces and of grades, sizes, and locations of reinforcement.
 - 4. Place grout only after inspectors have verified the following:
 - a. Preparation of grout, mortar, and prism specimens.
 - b. Proportions of site-prepared grout.
 - c. Sizes, spacings, and locations of anchor rods for steel ledgers where anchors are cast-in with grout.
 - 5. Place grout only after inspectors have verified size, spacing, and locations of anchor rods for steel ledgers where anchors are cast-in with grout.
 - 6. Place grout only after inspectors have verified proportions of site-prepared grout.
- C. Testing Prior to Construction: 1 set of tests.
- D. Testing Frequency: 1 set of tests for each 5,000 sq. ft. of wall area or portion thereof.
- E. [Clay Masonry Unit Test: For each type of unit provided, according to ASTM C67 for compressive strength.]

- F. Concrete Masonry Unit Test: For each type of unit provided, according to ASTM C140 for compressive strength.
 - G. Mortar Aggregate Ratio Test (Proportion Specification): For each mix provided, according to ASTM C780.
 - H. Grout Test (Compressive Strength): For each mix provided, according to ASTM C1019.
- 3.16 **[PARGING]**
- A. Parge exterior faces of below-grade masonry walls, where indicated, in two uniform coats to a total thickness of 3/4 inch. Dampen wall before applying first coat, and scarify first coat to ensure full bond to subsequent coat.
 - B. Use a steel-trowel finish to produce a smooth, flat, dense surface with a maximum surface variation of 1/8 inch per foot. Form a wash at top of parging and a cove at bottom.
 - C. Damp-cure parging for at least 24 hours and protect parging until cured.
- 3.17 REPAIR
- A. Remove and replace masonry units that are loose, chipped, broken, stained, or otherwise damaged or that do not match adjoining units. Install new units to match adjoining units; install in fresh mortar, pointed to eliminate evidence of replacement.
- 3.18 POINTING
- A. Pointing: During the tooling of joints, enlarge voids and holes, except weep holes, and completely fill with mortar. Point up joints, including corners, openings, and adjacent construction, to provide a neat, uniform appearance. Prepare joints for sealant application, where indicated.
- 3.19 CLEANING
- A. In-Progress Cleaning: Clean unit masonry as Work progresses by dry brushing to remove mortar fins and smears before tooling joints.
 - B. Final Cleaning: After mortar is thoroughly set and cured, clean exposed masonry as follows:
 1. Remove large mortar particles by hand with wooden paddles and nonmetallic scrape hoes or chisels.
 2. Test cleaning methods on sample wall panel; leave 1/2 of panel uncleaned for comparison purposes. Obtain Architect's approval of sample cleaning before proceeding with cleaning of masonry.
 3. Protect adjacent **[stone and]** nonmasonry surfaces from contact with cleaner by covering them with liquid strippable masking agent or polyethylene film and waterproof masking tape.
 4. Wet wall surfaces with water before applying cleaners; remove cleaners promptly by rinsing surfaces thoroughly with clear water.
 5. **[Clean brick by bucket-and-brush hand-cleaning method described in BIA Technical Notes 20.]**
 6. Clean concrete masonry by applicable cleaning methods indicated in NCMA TEK 8-4A.
 7. Clean masonry with a proprietary acidic cleaner applied according to manufacturer's written instructions.
 8. **[Clean stone trim to comply with stone supplier's written instructions.]**
 9. **[Clean limestone units to comply with recommendations in ILI's "Indiana Limestone Handbook."]**

3.20 MASONRY WASTE DISPOSAL

- A. Salvageable Materials: Unless otherwise indicated, excess masonry materials are Contractor's property. At completion of unit masonry Work, remove from Project site.
- B. Waste Disposal as Fill Material: Dispose of clean masonry waste, including excess or soil-contaminated sand, waste mortar, and broken masonry units, by crushing and mixing with fill material as fill is placed.
 - 1. Crush masonry waste to less than 4 inches in each dimension.
 - 2. Mix masonry waste with at least two parts of specified fill material for each part of masonry waste. Fill material is specified in Division 31 Section for Earth Moving.
 - 3. Do not dispose of masonry waste as fill within 18 inches of finished grade.
- C. Masonry Waste Recycling: Return broken CMUs not used as fill to manufacturer for recycling.
- D. Excess Masonry Waste: Remove excess clean masonry waste that cannot be used as fill, as described above or recycled, and other masonry waste, and legally dispose of off Owner's property.

END OF SECTION 042000

SECTION 042200
CONCRETE UNIT MASONRY

PART 1 - GENERAL

- A. Section Includes:
 - 1. Decorative concrete masonry units.
- 1.2 ACTION SUBMITTALS
 - A. Product Data: For each type of product.
 - B. Samples: For each type and color of the following:
 - 1. Decorative CMUs.
- 1.3 INFORMATIONAL SUBMITTALS
 - A. Material Certificates: For each type and size of product. For masonry units, include data on material properties.
 - B. Mix Designs: For each type of mortar and grout. Include description of type and proportions of ingredients.
 - 1. Include test reports, according to ASTM C1019, for grout mixes required to comply with compressive strength requirement.
- 1.4 DELIVERY, STORAGE, AND HANDLING
 - A. Store masonry units on elevated platforms in a dry location. If units are not stored in an enclosed location, cover tops and sides of stacks with waterproof sheeting, securely tied. If units become wet, do not install until they are dry.
 - B. Store cementitious materials on elevated platforms, under cover, and in a dry location. Do not use cementitious materials that have become damp.
 - C. Store aggregates where grading and other required characteristics can be maintained and contamination avoided.
 - D. Store masonry accessories to prevent corrosion and accumulation of dirt and oil.
- 1.5 FIELD CONDITIONS
 - A. Protection of Masonry: During construction, cover tops of walls, projections, and sills with waterproof sheeting at end of each day's Work. Cover partially completed masonry when construction is not in progress.
 - B. Cold-Weather Requirements: Do not use frozen materials or materials mixed or coated with ice or frost. Do not build on frozen substrates. Remove and replace unit masonry damaged by frost or by freezing conditions. Comply with cold-weather construction requirements contained in TMS 602.
 - C. Hot-Weather Requirements: Comply with hot-weather construction requirements contained in TMS 602.

PART 2 - PRODUCTS

2.1 MANUFACTURERS

- A. Manufacturers: Subject to compliance with requirements, provide products from one of the following:
 - 1. Basalite Concrete Products, LLC.
 - 2. Central Pre-Mix Concrete Products Co.
 - 3. Eastside Masonry Products.
 - 4. Mutual Materials Co.
 - 5. Western Materials.
 - 6. Willamette Graystone, Inc.
 - 7. Approved substitutions.
- B. Source Limitations for Masonry Units: Obtain exposed masonry units of a uniform texture and color, or a uniform blend within ranges accepted for these characteristics, from single source from single manufacturer for each product required.
- C. Source Limitations for Mortar Materials: Obtain mortar ingredients of a uniform quality, including color for exposed masonry, from single manufacturer for each cementitious component and from single source or producer for each aggregate.

2.2 UNIT MASONRY, GENERAL

- A. Masonry Standard: Comply with TMS 602, except as modified by requirements in Contract Documents.
- B. Defective Units: Referenced masonry unit standards may allow a certain percentage of units to contain chips, cracks, or other defects exceeding limits stated. Do not use units where such defects are exposed in completed Work and will be within 20 feet vertically and horizontally of a walking surface.

2.3 CONCRETE MASONRY UNITS

- A. Shapes: Provide shapes indicated and as follows, with exposed surfaces matching exposed faces of adjacent units unless otherwise indicated.
 - 1. Provide special shapes for lintels, corners, jambs, sashes, movement joints, headers, bonding, and other special conditions.
- B. Integral Water Repellent: Provide units made with integral water repellent for exposed units and where indicated.
 - 1. Integral Water Repellent: Liquid polymeric, integral water-repellent admixture that does not reduce flexural bond strength. Units made with integral water repellent, when tested according to ASTM E514 as wall assembly made with mortar containing integral water-repellent manufacturer's mortar additive, with test period extended to 24 hours, shall show no visible water or leaks on the back of test specimen.
 - a. Products: Subject to compliance with requirements, provide one of the following:
 - 1) ACM Chemistries: RainBloc.
 - 2) BASF Corporation: MasterPel 240 of MasterPel 200HD.
 - 3) Euclid Chemical Company (The): Eucon Blocktite.
 - 4) GCP Applied Technologies Inc.: Dry-Block.
 - 5) Moxie International: Moxie Shield 1800 Admixture.
- C. CMUs: ASTM C90.
 - 1. Unit Compressive Strength: Provide units with minimum average net-area compressive strength of 1,900 psi.
 - 2. Density Classification: Normal weight unless otherwise indicated.
 - 3. Size (Width): Manufactured to dimensions 3/8 inch less than nominal dimensions.

4. Exposed Faces: Provide color and texture matching range represented by Architect's sample.
- D. Decorative CMUs: ASTM C90.
1. Products: Subject to compliance with requirements, provide one of the following:
 - a. Basalite Concrete Products, LLC.
 - b. Echelon Masonry.
 - c. Elgin Butler.
 - d. Mutual Materials Co.
 - e. Spectra-Glaze.
 2. Unit Compressive Strength: Provide units with minimum average net-area compressive strength of 2,150 psi.
 3. Density Classification: Normal weight.
 4. Size (Width): Manufactured to dimensions specified in "CMUs" Paragraph.
 5. Pattern and Texture:
 - a. Standard pattern, split-face finish.
 6. Colors: Manufacturer's standard grey.
- 2.4 MORTAR AND GROUT MATERIALS
- A. Portland Cement: ASTM C150, Type I or II, except Type III may be used for cold-weather construction. Provide natural color or white cement as required to produce mortar color indicated.
1. Alkali content shall not be more than 0.1 percent when tested according to ASTM C114.
- B. Hydrated Lime: ASTM C207, Type S.
- C. Portland Cement-Lime Mix: Packaged blend of portland cement and hydrated lime containing no other ingredients.
- D. Masonry Cement: Not allowed.
- E. Mortar Cement: ASTM C1329.
1. Products: Subject to compliance with requirements, provide one of the following:
 - a. Blue Circle Cement: Magnolia Superbond Mortar Cement.
 - b. Lafarge North America Inc.: Lafarge Mortar Cement.
 - c. SPEC MIX, Inc.: Mortar Cement & Sand.
- F. Aggregate for Mortar: ASTM C144.
1. White-Mortar Aggregates: Natural white sand or crushed white stone.
- G. Aggregate for Grout: ASTM C404.
- H. Cold-Weather Admixture: Nonchloride, noncorrosive, accelerating admixture complying with ASTM C494/, Type C, and recommended by manufacturer for use in masonry mortar of composition indicated.
1. Products: Subject to compliance with requirements, provide one of the following:
 - a. Addiment Incorporated: Mortar Kick.
 - b. Euclid Chemical Company (The): Accelguard 80.
 - c. GCP Applied Technologies Inc.: Morset.
- I. Water-Repellent Admixture: Liquid water-repellent mortar admixture intended for use with CMUs containing integral water repellent from same manufacturer.
1. Products: Subject to compliance with requirements, provide one of the following:
 - a. ACM Chemistries: RainBloc for Mortar.
 - b. GCP Applied Technologies Inc.: Dry-Block Mortar Admixture.
 - c. Master Builders Solutions by BASF: MasterPel 240MA.
 - d. SPEC MIX, Inc.: Preblended Integral Water Repellent (IWR) Masonry Mortar.
- J. Water: Potable.

2.5 REINFORCEMENT

- A. Masonry Joint Reinforcement, General: ASTM A951.
 - 1. Exterior Walls: Stainless steel.
 - 2. Wire Size for Side Rods: 0.187 inch diameter.
 - 3. Wire Size for Cross Rods: 0.187 inch diameter.
 - 4. Spacing of Cross Rods, Tabs, and Cross Ties: Not more than 16 inches on center.
 - 5. Provide in lengths of not less than 10 feet, with prefabricated corner and tee units.
- B. Masonry-Joint Reinforcement for Single-Wythe Masonry: Ladder type with single pair of side rods.

2.6 EMBEDDED FLASHING MATERIALS

- A. Flexible Flashing: Use the following unless otherwise indicated:
 - 1. Rubberized-Asphalt Flashing: Composite flashing product consisting of a pliable, adhesive rubberized-asphalt compound, bonded to a high-density, cross-laminated polyethylene film.
 - a. Products: Subject to compliance with requirements, provide 1 of the following:
 - 1) Advanced Building Products Inc.: Peel-N-Seal.
 - 2) Carlisle Coatings & Waterproofing: CCW-705-TWF Thru-Wall Flashing.
 - 3) Fiberweb—Clark Hammerbeam Corp.: Aquaflash 500.
 - 4) GCP Applied Technologies Inc.: Perm-A-Barrier Wall Flashing.
 - 5) Henry Company: Blueskin SA or Fortiflash 40.
 - 6) Polyguard Products, Inc.: Polyguard 400.
 - 7) Tremco, Inc.: ExoAir TWF.
 - 8) W. R. Meadows, Inc.: Air-Shield Thru-Wall Flashing.
 - 9) York Manufacturing, Inc.: York Seal Flashing.
 - b. Overall Thickness: Not less than 40 mils (0.040 inch).
 - c. Accessories: Provide preformed corners, end dams, other special shapes, and seaming materials produced by flashing manufacturer.
- B. Adhesives, Primers, and Seam Tapes for Flashings: Flashing manufacturer's standard products or products recommended by flashing manufacturer for bonding flashing sheets to each other and to substrates.

2.7 MORTAR AND GROUT MIXES

- A. General: Do not use admixtures, including pigments, air-entraining agents, accelerators, retarders, water-repellent agents, antifreeze compounds, or other admixtures unless otherwise indicated.
 - 1. Do not use calcium chloride in mortar or grout.
 - 2. Use portland cement-lime or mortar cement mortar unless otherwise indicated.
 - 3. Add cold-weather admixture (if used) at same rate for mortar that will be exposed to view, regardless of weather conditions, to ensure that mortar color is consistent.
- B. Mortar for Unit Masonry: Comply with ASTM C270, Proportion Specification. Provide the following types of mortar for applications stated unless another type is indicated or needed to provide required compressive strength of masonry.
 - 1. Type M: 2,500 psi; for masonry in contact with earth and walls below grade.
 - 2. Type S: 1,800 psi; for exterior, above-grade, non-load-bearing walls and for other applications where another type is not indicated.
- C. Grout for Unit Masonry: Comply with ASTM C476.
 - 1. Use grout of type indicated or, if not otherwise indicated, of type (fine or coarse) that will comply with TMS 602 for dimensions of grout spaces and pour height.

PART 3 - EXECUTION

3.1 INSTALLATION, GENERAL

- A. Use full-size units without cutting if possible. If cutting is required to provide a continuous pattern or to fit adjoining construction, cut units with motor-driven saws; provide clean, sharp, unchipped edges. Allow units to dry before laying unless wetting of units is specified. Install cut units with cut surfaces and, where possible, cut edges concealed.

3.2 TOLERANCES

A. Dimensions and Locations of Elements:

1. For dimensions in cross section or elevation, do not vary by more than plus 1/2 inch or minus 1/4 inch.
2. For location of elements in plan, do not vary from that indicated by more than plus or minus 1/2 inch.
3. For location of elements in elevation, do not vary from that indicated by more than plus or minus 1/4 inch in a story height or 1/2 inch total.

B. Lines and Levels:

1. For bed joints and top surfaces of bearing walls, do not vary from level by more than 1/4 inch in 10 feet, or 1/2-inch maximum.
2. For conspicuous horizontal lines, such as lintels, sills, parapets, and reveals, do not vary from level by more than 1/8 inch in 10 feet, 1/4 inch in 20 feet, or 1/2-inch maximum.
3. For vertical lines and surfaces, do not vary from plumb by more than 1/4 inch in 10 feet, 3/8 inch in 20 feet, or 1/2-inch maximum.
4. For conspicuous vertical lines, such as external corners, door jambs, reveals, and expansion and control joints, do not vary from plumb by more than 1/8 inch in 10 feet, 1/4 inch in 20 feet, or 1/2-inch maximum.
5. For lines and surfaces, do not vary from straight by more than 1/4 inch in 10 feet, 3/8 inch in 20 feet, or 1/2-inch maximum.

C. Joints:

1. For bed joints, do not vary from thickness indicated by more than plus or minus 1/8 inch, with a maximum thickness limited to 1/2 inch.
2. For head and collar joints, do not vary from thickness indicated by more than plus 3/8 inch or minus 1/4 inch.
3. For exposed head joints, do not vary from thickness indicated by more than plus or minus 1/8 inch.

3.3 LAYING MASONRY WALLS

- A. Lay out walls in advance for accurate spacing of surface bond patterns with uniform joint thicknesses and for accurate location of openings, movement-type joints, returns, and offsets. Avoid using less-than-half-size units, particularly at corners, jambs, and, where possible, at other locations.
- B. Bond Pattern for Exposed Masonry: Unless otherwise indicated, lay exposed masonry in running bond. Do not use units with less-than-nominal 4 inch horizontal face dimensions at corners or jambs.
- C. Built-in Work: As construction progresses, build in items specified in this and other Sections. Fill in solidly with masonry around built-in items.
- D. Where built-in items are to be embedded in cores of hollow masonry units, place a layer of metal lath, wire mesh, or plastic mesh in the joint below, and rod mortar or grout into core.
- E. Fill cores in hollow CMUs with grout 24 inches under bearing plates, beams, lintels, posts, and similar items unless otherwise indicated.

3.4 MORTAR BEDDING AND JOINTING

- A. Lay hollow CMUs as follows:
 - 1. Bed face shells in mortar and make head joints of depth equal to bed joints.
 - 2. Bed webs in mortar in all courses of piers, columns, and pilasters.
 - 3. Bed webs in mortar in grouted masonry, including starting course on footings.
 - 4. Fully bed entire units, including areas under cells, at starting course on footings where cells are not grouted.
- B. Lay solid CMUs with completely filled bed and head joints; butter ends with sufficient mortar to fill head joints and shove into place. Do not deeply furrow bed joints or slush head joints.
- C. Tool exposed joints slightly concave when thumbprint hard, using a jointer larger than joint thickness unless otherwise indicated.

3.5 MASONRY-JOINT REINFORCEMENT

- A. General: Install entire length of longitudinal side rods in mortar with a minimum cover of 5/8 inch on exterior side of walls, 1/2 inch elsewhere. Lap reinforcement a minimum of 6 inches.
 - 1. Provide reinforcement not more than 8 inches above and below wall openings and extending 12 inches beyond openings in addition to continuous reinforcement.
- B. Provide continuity at wall intersections by using prefabricated T-shaped units.

3.6 FLASHING

- A. General: Install embedded flashing at ledges and other obstructions to downward flow of water in wall where indicated.

3.7 FIELD QUALITY CONTROL

- A. Testing and Inspecting: Owner will engage special inspectors to perform tests and inspections and prepare reports. Allow inspectors access to scaffolding and work areas as needed to perform tests and inspections. Retesting of materials that fail to comply with specified requirements shall be done at Contractor's expense.

3.8 POINTING

- A. Pointing: During tooling of joints, enlarge voids and holes, except weep holes, and completely fill with mortar. Point up joints, including corners, openings, and adjacent construction, to provide a neat, uniform appearance. Prepare joints for sealant application, where indicated.

3.9 CLEANING

- A. In-Progress Cleaning: Clean unit masonry as Work progresses by dry brushing to remove mortar fins and smears before tooling joints.
- B. Final Cleaning: After mortar is thoroughly set and cured, clean exposed masonry as follows:
 - 1. Test cleaning methods on sample wall panel; leave 1/2 of panel uncleaned for comparison purposes. Obtain Architect's approval of sample cleaning before proceeding with cleaning of masonry.
 - 2. Clean concrete masonry by applicable cleaning methods indicated in NCMA TEK 8-4A.

3.10 MASONRY WASTE DISPOSAL

- A. Salvageable Materials: Unless otherwise indicated, excess masonry materials are Contractor's property. At completion of unit masonry Work, remove from Project site.
- B. Waste Disposal as Fill Material: Dispose of clean masonry waste, including excess or soil-contaminated sand, waste mortar, and broken masonry units, by crushing and mixing with fill material as fill is placed.
 - 1. Crush masonry waste to less than 4 inches in each dimension.
 - 2. Mix masonry waste with at least two parts of specified fill material for each part of masonry waste. Fill material is specified in Division 31 Section for Earth Moving.
 - 3. Do not dispose of masonry waste as fill within 18 inches of finished grade.
- C. Masonry Waste Recycling: Return broken CMUs not used as fill to manufacturer for recycling.
- D. Excess Masonry Waste: Remove excess clean masonry waste that cannot be used as fill, as described above or recycled, and other masonry waste, and legally dispose of off Owner's property.

END OF SECTION 042200

SECTION 051200
STRUCTURAL STEEL FRAMING

PART 1 - GENERAL

1.1 SUMMARY

- A. Section Includes:
1. Structural steel.
 2. Shear stud connectors.
 3. Shrinkage-resistant grout.

1.2 ADMINISTRATIVE REQUIREMENTS

- A. Coordination:
1. Coordinate selection of shop primers with topcoats to be applied over them. Comply with paint and coating manufacturers' recommendations to ensure that shop primers and topcoats are compatible with one another.
 2. Coordinate installation of anchorage items to be embedded in or attached to other construction without delaying Work. Provide embedment drawings, setting diagrams, sheet metal templates, instructions, and directions for installation.
- B. Preinstallation Meeting: Conduct meeting at Project site.
1. Meeting Time: Schedule meeting a minimum of 2 weeks prior to beginning Work of this Section and related Work.
 2. Attendees: Owner, Architect, structural engineer, Contractor, Contractor's superintendent, independent testing agency responsible for steel inspections, steel erection Subcontractor, manufacturer representatives of structural steel, steel joist, and steel decks, steel fabricator, and other entities as requested to attend.
 3. Before submitting design mixtures, review concrete design mixture and examine procedures for ensuring quality of concrete materials.
 4. Agenda Items:
 - a. Review the following items:
 - 1) Project chain of communications.
 - 2) Project schedule, fabrication and erection procedures and schedules.
 - 3) Bolting and welding procedures.
 - 4) Temporary frame stability/shoring procedures.
 - 5) WPSs and WPQRs for completeness and applicability.
 - b. Discuss safety issues, procedures for addressing non-conformance in shop and field, RFI procedures, and unique steel members or conditions that warrant special attention or erection sequencing.
 - c. Special Inspections and Testing Agency Procedures:
 - 1) Coordinate shop and field quality control with fabricator and erector.
 - 2) Verify fabricator and erector's QA procedures including joist installation and metal roof deck attachment procedures.
 - 3) Coordination of inspections,

1.3 ACTION SUBMITTALS

- A. Product Data:
1. Structural-steel materials.
 2. High-strength, bolt-nut-washer assemblies.
 3. Shear stud connectors.
 4. Anchor rods.

5. Threaded rods.
 6. Shop primer.
 7. Galvanized-steel primer.
 8. Etching cleaner.
 9. Galvanized repair coating.
- B. Sustainable Design Submittals:
1. Environmental Product Declaration (EPD): For each product.
 2. Health Product Declaration (HPD): For each product.
 3. Sourcing of Raw Materials: Corporate sustainability report for each manufacturer.
- C. Shop Drawings: Show fabrication of structural-steel components.
1. Include details of cuts, connections, splices, camber, holes, and other pertinent data.
 2. Include embedment Drawings.
 3. Indicate welds by standard AWS symbols, distinguishing between shop and field welds, and show size, length, and type of weld. Show backing bars that are to be removed and supplemental fillet welds where backing bars are to remain.
 4. Indicate type, size, and length of bolts, distinguishing between shop and field bolts.
 5. Identify members and connections of seismic-force-resisting system.
 6. Indicate locations and dimensions of protected zones.
 7. Identify demand-critical welds.
 8. Identify members not to be shop primed.
 9. Submit Shop Drawings that have been engineered and certified by professional engineer licensed in the State in which Project is located. Include seal and signature of professional engineer on Shop Drawings.
- D. Welding Procedure Specifications (WPSs) and Welding Procedure Qualification Records (WPQRs): Provide according to AWS D1.1 for each welded joint whether prequalified or qualified by testing, including the following:
1. Power source (constant current or constant voltage).
 2. Electrode manufacturer and trade name, for demand critical welds.
- 1.4 INFORMATIONAL SUBMITTALS
- A. Qualification Data:
1. For Installer and fabricator.
- B. Welding certificates.
- C. Quality Control (QC) Manuals: Fabricators' and erectors' written manuals for quality control procedures. Include minimally acceptable material control procedures, inspection procedures, and procedures for correction of non-conformance necessary to ensure quality of erected structural steel according to AISC
- D. Paint Compatibility Certificates: From manufacturers of topcoats applied over shop primers, certifying that shop primers are compatible with topcoats.
- E. Steel Primer Certification: From steel fabricator for specific surface preparation procedures and primers used for fabricated steel items to verify compliance with Specifications and compatibility of finish coat materials.
- F. Mill test reports for structural steel, including chemical and physical properties.
- G. Product Test Reports: For the following:
1. Bolts, nuts, and washers, including mechanical properties and chemical analysis.
 2. Direct-tension indicators.
 3. Tension-control, high-strength, bolt-nut-washer assemblies.
 4. Shear stud connectors.

5. Shop primers.
6. Nonshrink grout.

1.5 QUALITY ASSURANCE

- A. Fabricator Qualifications: A qualified fabricator with a minimum of 5 years documented experience with commercial quality work comparable in scope to this Project.
- B. Installer Qualifications: A qualified installer with a minimum of 5 years documented experience with commercial quality work comparable in scope to this Project.
- C. Shop-Painting Applicators: An installer with a minimum of 5 years documented experience with commercial quality work comparable in scope to this Project.
- D. Welding Qualifications: Qualify procedures and personnel according to AWS D1.1.
 1. Welders and welding operators performing Work on bottom-flange, demand-critical welds shall pass supplemental welder qualification testing, as required by AWS D1.8. FCAW-S and FCAW-G shall be considered separate processes for welding personnel qualification.

1.6 DELIVERY, STORAGE, AND HANDLING

- A. Store materials to permit easy access for inspection and identification. Keep steel members off ground and spaced by using pallets, dunnage, or other supports and spacers. Protect steel members and packaged materials from corrosion and deterioration.
 1. Do not store materials on structure in a manner that might cause distortion, damage, or overload to members or supporting structures. Repair or replace damaged materials or structures as directed.
- B. Store fasteners in a protected place in sealed containers with manufacturer's labels intact.
 1. Fasteners may be repackaged provided Owner's testing and inspecting agency observes repackaging and seals containers.
 2. Clean and relubricate bolts and nuts that become dry or rusty before use.
 3. Comply with manufacturers' written recommendations for cleaning and lubricating ASTM F3125, Grade F1852 bolt assemblies and for retesting bolt assemblies after lubrication.

PART 2 - PRODUCTS

2.1 PERFORMANCE CRITERIA

- A. Comply with applicable provisions of the following specifications and documents:
 1. ANSI/AISC 303.
 2. ANSI/AISC 341.
 3. ANSI/AISC 360.
 4. RCSC's "Specification for Structural Joints Using High-Strength Bolts."
- B. Connection Design Information:
 1. Option 1: Connection designs have been completed and connections indicated on Drawings.

2.2 STRUCTURAL-STEEL MATERIALS

- A. Recycled Content of Steel Products: Provide products with an average recycled content of steel products so postconsumer recycled content plus one-half of preconsumer recycled content is not less than the following:
 1. W-Shapes: 60 percent.
 2. Channels, Angles, M, S-Shapes: 60 percent.
 3. Plate and Bar: 25 percent.
 4. Cold-Formed Hollow Structural Sections: 25 percent.

- 5. Steel Pipe: 25 percent.
 - 6. Other Steel Materials: 25 percent.
 - B. W-Shapes: ASTM A992.
 - C. Channels, Angles, Plates, and Bars: ASTM A36.
 - D. Cold-Formed Hollow Structural Sections: ASTM A500, Grade B, structural tubing.
 - E. Steel Pipe: ASTM A53, Type E or Type S, Grade B.
 - 1. Weight Class: As required according to approved Shop Drawings.
 - 2. Finish: Black, except where indicated to be galvanized.
 - F. Steel Castings: ASTM A216, Grade WCB with supplementary requirement S11.
 - G. Steel Forgings: ASTM A668.
 - H. Welding Electrodes: Comply with AWS requirements and structural Drawing General Notes.
 - 1. Provide low-hydrogen welding electrodes that comply with ASTM E7018 for welding to SFRS.
- 2.3 BOLTS, CONNECTORS, AND ANCHORS
- A. High-Strength Bolts, Nuts, and Washers: ASTM F3125, Grade A325, Type 1, heavy-hex steel structural bolts; ASTM A563, Grade DH, heavy-hex carbon-steel nuts; and ASTM F436, Type 1, hardened carbon-steel washers; all with plain finish.
 - 1. Direct-Tension Indicators: ASTM F959, Type 325-1, compressible-washer type with plain finish.
 - B. Tension-Control, High-Strength Bolt-Nut-Washer Assemblies: ASTM F3125, Grade F1852, Type 1, heavy-hex head assemblies consisting of steel structural bolts with splined ends; ASTM A563, Grade DH, heavy-hex carbon-steel nuts; and ASTM F436, Type 1, hardened carbon-steel washers.
 - 1. Finish: Plain.
 - C. Shear Stud Connectors: ASTM A108, Grades 1015 through 1020, headed-stud type, cold-finished carbon steel; AWS D1.1, Type B.
- 2.4 RODS
- A. Unheaded Anchor Rods: ASTM F1554, Grade 36.
 - 1. Configuration: Hooked.
 - 2. Nuts: ASTM A563 heavy-hex carbon steel.
 - 3. Plate Washers: ASTM A36 carbon steel.
 - 4. Washers: ASTM F436, Type 1, hardened carbon steel.
 - 5. Finish: Plain.
 - B. Headed Anchor Rods: ASTM F1554, Grade 36, straight.
 - 1. Nuts: ASTM A563 heavy-hex carbon steel.
 - 2. Plate Washers: ASTM A36 carbon steel.
 - 3. Washers: ASTM F436, Type 1, hardened carbon steel.
 - 4. Finish: Plain.
 - C. Threaded Rods: ASTM A36.
 - 1. Nuts: ASTM A563 heavy-hex carbon steel.
 - 2. Washers: ASTM A36 carbon steel.
 - 3. Finish: Plain.
- 2.5 PRIMER
- A. Steel Primer:

1. Comply with Section 099600 – High-Performance Coatings.
 2. Fabricator's standard fast-curing, lead- and chromate-free, nonasphaltic, rust-inhibiting, primer complying with MPI #79 and compatible with topcoat.
 3. Use primer containing pigments that make it easily distinguishable from zinc-rich primer.
- B. Galvanized Steel Primer:
1. Vinyl wash primer complying with MPI #80.
 2. Water-based galvanized metal primer complying with MPI #134.
 3. Etching Cleaner: MPI #25 for galvanized metal as specified in Section 099000.
- 2.6 SHRINKAGE-RESISTANT GROUT
- A. Nonmetallic, Shrinkage-Resistant Grout: ASTM C1107, factory-packaged, nonmetallic aggregate grout, noncorrosive and nonstaining, mixed with water to consistency suitable for application and a 30 minute working time.
- 2.7 FABRICATION
- A. Structural Steel: Fabricate and assemble in shop to greatest extent possible. Fabricate according to ANSI/AISC 303, "Code of Standard Practice for Steel Buildings and Bridges," and to ANSI/AISC 360.
1. Camber structural-steel members where indicated.
 2. Fabricate beams with rolling camber up.
 3. Identify high-strength structural steel according to ASTM A6 and maintain markings until structural steel has been erected.
 4. Mark and match-mark materials for field assembly.
 5. Complete structural-steel assemblies, including welding of units, before starting shop-priming operations.
- B. Thermal Cutting: [**Perform thermal cutting by machine to greatest extent possible**] [**Not allowed**].
1. Plane thermally cut edges to be welded to comply with requirements in AWS D1.1.
- C. Bolt Holes: Cut, drill, mechanically thermal cut, or punch standard bolt holes perpendicular to metal surfaces as indicated on structural Drawings.
- D. Finishing: Accurately finish ends of columns and other members transmitting bearing loads.
- E. Cleaning: Clean and prepare steel surfaces that are to remain unpainted according to SSPC-SP 3.
- F. Shear Stud Connectors: Prepare steel surfaces as recommended by manufacturer of shear connectors. Use automatic end welding of headed-stud shear connectors according to AWS D1.1 and manufacturer's written instructions.
- G. Holes: Provide holes required for securing other Work to structural steel and for other Work to pass through steel members.
1. Cut, drill, or punch holes perpendicular to steel surfaces.
 2. Baseplate Holes: Cut, drill, mechanically thermal cut, or punch holes perpendicular to steel surfaces.
 3. Weld threaded nuts to framing and other specialty items indicated to receive other Work.
- 2.8 SHOP CONNECTIONS
- A. High-Strength Bolts: Shop install high-strength bolts according to RCSC's "Specification for Structural Joints Using High-Strength Bolts" for type of bolt and type of joint specified.
1. Joint Type: Snug tightened unless indicated otherwise.
- B. Weld Connections: Comply with AWS D1.1 and AWS D1.8 for tolerances, appearances, welding procedure specifications, weld quality, and methods used in correcting welding Work.

1. Assemble and weld built-up sections by methods that maintain true alignment of axes without exceeding tolerances in ANSI/AISC 303 for mill material.

2.9 GALVANIZING

- A. Hot-Dip Galvanized Finish: Apply zinc coating by hot-dip process to structural steel according to ASTM A123.
 1. Do not quench or apply post-galvanizing treatments that might interfere with paint adhesion.
 2. Fill vent and drain holes that are exposed in finished Work unless they function as weep holes, by plugging with zinc solder and filing off smooth.
 3. Galvanize lintels and shelf angles attached to structural-steel frame and located in exterior walls.
- B. Galvanizing Repair Coating: Zinc-rich, cold galvanizing compound as specified in Section 055000 – Metal Fabrications.

2.10 SHOP PRIMING

- A. Shop prime steel surfaces except the following:
 1. Surfaces embedded in concrete or mortar. Extend priming of partially embedded members to a depth of 2 inches.
 2. Surfaces to be field welded.
 3. Galvanized surfaces unless indicated to be painted.
 4. Surfaces enclosed in interior construction.
- B. Surface Preparation of Steel: Clean surfaces to be painted. Remove loose rust and mill scale and spatter, slag, or flux deposits. Prepare surfaces according to the following specifications and standards:
 1. SSPC-SP 3: Interior Steel.
 2. SSPC-SP 6 (WAB)/NACE WAB-3: Exterior steel, steel indicated as AESS, and steel indicated to receive high-performance coatings.
- C. Surface Preparation of Galvanized Steel: Prepare galvanized-steel surfaces for shop priming by thoroughly cleaning steel of grease, dirt, oil, flux, and other foreign matter, and treating with etching cleaner or in accordance with SSPC-SP 16.
- D. Priming: Immediately after surface preparation, apply primer according to manufacturer's written instructions and at rate recommended by SSPC to provide a minimum dry film thickness of 1.5 mils. Use priming methods that result in full coverage of joints, corners, crevices, bolts, welds, sharp edges, and exposed surfaces.
 1. Apply 2 coats of shop paint to surfaces that are inaccessible after assembly or erection. Change color of second coat to distinguish it from first.

2.11 SOURCE QUALITY CONTROL

- A. Testing Agency: Owner may engage a qualified testing agency to perform shop tests and inspections.
 1. Provide testing agency with access to places where structural-steel Work is being fabricated or produced to perform tests and inspections.
- B. Bolted Connections: Inspect and test shop-bolted connections according to RCSC's "Specification for Structural Joints Using High-Strength Bolts."
- C. Welded Connections: Visually inspect shop-welded connections according to AWS D1.1 and the following inspection procedures, at testing agency's option:
 1. Liquid Penetrant Inspection: ASTM E165.

2. Magnetic Particle Inspection: ASTM E709; performed on root pass and on finished weld. Cracks or zones of incomplete fusion or penetration are not accepted.
 3. Ultrasonic Inspection: ASTM E164.
- D. In addition to visual inspection, test and inspect shop-welded shear connectors according to requirements in AWS D1.1 for stud welding and as follows:
1. Perform bend tests if visual inspections reveal either a less-than-continuous 360-degree flash or welding repairs to any shear connector.
 2. Conduct tests according to requirements in AWS D1.1 on additional shear connectors if weld fracture occurs on shear connectors already tested.
- E. Prepare test and inspection reports.

PART 3 - EXECUTION

3.1 EXAMINATION

- A. Verify, with certified steel erector present, elevations of concrete- and masonry-bearing surfaces and locations of anchor rods, bearing plates, and other embedments for compliance with requirements.
1. Prepare a certified survey of existing conditions. Include bearing surfaces, anchor rods, bearing plates, and other embedments showing dimensions, locations, angles, and elevations.
- B. Proceed with installation only after unsatisfactory conditions have been corrected.

3.2 PREPARATION

- A. Provide temporary shores, guys, braces, and other supports during erection to keep structural steel secure, plumb, and in alignment against temporary construction loads and loads equal in intensity to design loads. Remove temporary supports when permanent structural steel, connections, and bracing are in place unless otherwise indicated.

3.3 ERECTION

- A. Set structural steel accurately in locations and to elevations indicated and according to ANSI/AISC 303 and ANSI/AISC 360.
- B. Baseplates, Bearing Plates, and Leveling Plates: Clean concrete- and masonry-bearing surfaces of bond-reducing materials, and roughen surfaces prior to setting plates. Clean bottom surface of plates.
1. Set plates for structural members on wedges, shims, or setting nuts as required.
 2. Weld plate washers to top of baseplate.
 3. Snug-tighten anchor rods after supported members have been positioned and plumbed. Do not remove wedges or shims but, if protruding, cut off flush with edge of plate before packing with grout.
 4. Promptly pack grout solidly between bearing surfaces and plates so no voids remain. Neatly finish exposed surfaces; protect grout and allow to cure. Comply with manufacturer's written installation instructions for shrinkage-resistant grouts.
- C. Maintain erection tolerances of structural steel within ANSI/AISC 303.
- D. Align and adjust various members that form part of complete frame or structure before permanently fastening. Before assembly, clean bearing surfaces and other surfaces that are in permanent contact with members. Perform necessary adjustments to compensate for discrepancies in elevations and alignment.
1. Level and plumb individual members of structure.
 2. Make allowances for difference between temperature at time of erection and mean temperature when structure is completed and in service.

- E. Splice members only where indicated.
- F. Do not use thermal cutting during erection unless approved by Architect. Finish thermally cut sections within smoothness limits in AWS D1.1.
- G. Do not enlarge unfair holes in members by burning or using drift pins. Ream holes that must be enlarged to admit bolts.
- H. Shear Stud Connectors: Prepare steel surfaces as recommended by manufacturer of shear connectors. Use automatic end welding of headed-stud shear connectors according to AWS D1.1 and manufacturer's written instructions.

3.4 FIELD CONNECTIONS

- A. High-Strength Bolts: Install high-strength bolts according to RCSC's "Specification for Structural Joints Using High-Strength Bolts" for type of bolt and type of joint specified.
 - 1. Joint Type: Snug tightened unless indicated otherwise.
- B. Weld Connections: Comply with AWS D1.1 and AWS D1.8 for tolerances, appearances, welding procedure specifications, weld quality, and methods used in correcting welding Work.
 - 1. Comply with ANSI/AISC 303 and ANSI/AISC 360 for bearing, alignment, adequacy of temporary connections, and removal of paint on surfaces adjacent to field welds.
 - 2. Remove backing bars or runoff tabs where indicated, back gouge, and grind steel smooth.
 - 3. Assemble and weld built-up sections by methods that maintain true alignment of axes without exceeding tolerances in ANSI/AISC 303, "Code of Standard Practice for Steel Buildings and Bridges," for mill material.

3.5 FIELD QUALITY CONTROL

- A. Special Inspections: Owner will engage a qualified special inspector to perform the following special inspections:
 - 1. Verify structural-steel materials and inspect steel frame joint details.
 - 2. Verify weld materials and inspect welds.
 - 3. Verify connection materials and inspect high-strength bolted connections.
- B. Testing Agency: Owner will engage a qualified testing agency to perform tests and inspections.
- C. Bolted Connections: Inspect and test bolted connections according to RCSC's "Specification for Structural Joints Using High-Strength Bolts."
- D. Welded Connections: Visually inspect field welds according to AWS D1.1.
 - 1. In addition to visual inspection, inspect and test field welds according to AWS D1.1 and the following inspection procedures, at testing agency's option:
 - a. Liquid Penetrant Inspection: ASTM E165.
 - b. Magnetic Particle Inspection: ASTM E709; performed on root pass and on finished weld. Cracks or zones of incomplete fusion or penetration are not accepted.
 - c. Ultrasonic Inspection: ASTM E164.
 - d. Radiographic Inspection: ASTM E94.
- E. In addition to visual inspection, test and inspect field-welded shear connectors according to requirements in AWS D1.1 for stud welding and as follows:
 - 1. Perform bend tests if visual inspections reveal either a less-than-continuous 360-degree flash or welding repairs to any shear connector.
 - 2. Conduct tests according to requirements in AWS D1.1 on additional shear connectors if weld fracture occurs on shear connectors already tested.

3.6 REPAIR

- A. Galvanized Surfaces: Clean field welds, bolted connections, and abraded areas, and repair with galvanizing repair coating.
- B. Touchup Painting: Immediately after erection, clean exposed areas where primer is damaged or missing and paint with same material as used for shop painting to comply with SSPC-PA 1 for touching up shop-painted surfaces.
 - 1. Clean and prepare surfaces by SSPC-SP 2 hand-tool cleaning or SSPC-SP 3 power-tool cleaning.
- C. Touchup Priming: Cleaning and touchup priming are specified in Section 099600 – High Performance Coatings.

END OF SECTION 051200

SECTION 055000
METAL FABRICATIONS

PART 1 - GENERAL

1.1 SUMMARY

A. Section Includes:

1. Steel framing and supports for:
 - a. Operable partitions.
 - b. Countertops.
 - c. Mechanical and electrical equipment.
 - d. Applications where framing and supports are not specified in other Sections.
2. Elevator machine beams and divider beams.
3. Steel shapes for supporting elevator door sills.
4. Shelf angles.
5. Elevator pit sump covers.
6. Abrasive metal nosings.

1.2 ADMINISTRATIVE REQUIREMENTS

A. Coordination:

1. Coordinate selection of shop primers with topcoats to be applied over them. Comply with paint and coating manufacturers' written recommendations to ensure that shop primers and topcoats are compatible with one another.
2. Coordinate installation of metal fabrications that are anchored to or that receive other Work. Furnish setting drawings, templates, and directions for installing anchorages, including sleeves, concrete inserts, anchor bolts, and items with integral anchors, that are to be embedded in concrete or masonry. Deliver such items to Project site in time for installation.

1.3 ACTION SUBMITTALS

A. Product Data: For the following:

1. Fasteners.
2. Shop primers.
3. Shrinkage-resisting grout.
4. Abrasive metal nosings.

B. Shop Drawings: Show fabrication and installation details. Include plans, elevations, sections, and details of metal fabrications and their connections. Show anchorage and accessory items. Provide Shop Drawings for the following:

1. Steel framing and supports for:
 - a. Countertops.
 - b. Mechanical and electrical equipment.
 - c. Applications where framing and supports are not specified in other Sections.
2. Elevator machine beams, hoist beams, and divider beams.
3. Steel shapes for supporting elevator door sills.
4. Steel pipe columns for supporting wood frame construction.
5. Shelf angles.
6. Elevator pit sump covers.
7. Loose steel lintels.

C. Samples for Verification: For each type and finish of extruded nosing.

1.4 INFORMATIONAL SUBMITTALS

- A. Qualification Data: For professional engineer.
- B. Welding certificates.
- C. Paint Compatibility Certificates: From manufacturers of topcoats applied over shop primers, certifying that shop primers are compatible with topcoats.
- D. Research/Evaluation Reports: For post-installed anchors, from ICC-ES.

1.5 QUALITY ASSURANCE

- A. Welding Qualifications: Qualify procedures and personnel according to the following:
 - 1. AWS D1.1, "Structural Welding Code - Steel."

PART 2 - PRODUCTS

2.1 PERFORMANCE CRITERIA

- A. Thermal Movements: Allow for thermal movements from ambient and surface temperature changes acting on exterior metal fabrications by preventing buckling, opening of joints, overstressing of components, failure of connections, and other detrimental effects.
 - 1. Temperature Change: 120 deg F, ambient; 180 deg F, material surfaces.

2.2 METALS

- A. Metal Surfaces, General: Provide materials with smooth, flat surfaces unless otherwise indicated. For metal fabrications exposed to view in completed Work, provide materials without seam marks, roller marks, rolled trade names, or blemishes.
- B. Recycled Content of Steel Products: Postconsumer recycled content plus 1/2 of preconsumer recycled content not less than 25 percent.
- C. Steel Plates, Shapes, and Bars: ASTM A36.
- D. Steel Tubing: ASTM A500, cold-formed steel tubing.
- E. Steel Pipe: ASTM A53, Standard Weight (Schedule 40) unless otherwise indicated.
- F. Cast Iron: Either gray iron, ASTM A48, or malleable iron, ASTM A47, unless otherwise indicated.
- G. Aluminum Plate and Sheet: ASTM B209, Alloy 6061-T6.
- H. Aluminum Extrusions: ASTM B221, Alloy 6063-T6.

2.3 FASTENERS

- A. Unless otherwise indicated, provide Type 304 stainless-steel fasteners for exterior use and zinc-plated fasteners with coating complying with ASTM B633 or ASTM F1941, Class Fe/Zn 5, at exterior walls.
 - 1. Select fasteners for type, grade, and class required.
 - 2. Provide stainless-steel fasteners for fastening aluminum, stainless steel, and nickel silver.
- B. Steel Bolts and Nuts: Regular hexagon-head bolts, ASTM A307, Grade A; with hex nuts, ASTM A563; and, where indicated, flat washers.

- C. Anchor Bolts: ASTM F1554, Grade 36, of dimensions indicated; with nuts, ASTM A563; and, where indicated, flat washers.
 - 1. Provide hot-dip galvanized or mechanically deposited, zinc coating where item being fastened is indicated to be galvanized.
- D. Anchors, General: Capable of sustaining, without failure, a load equal to 4 times the load imposed when installed in concrete, as determined by testing per ASTM E488, conducted by a qualified independent testing agency.
- E. Cast-in-Place Anchors in Concrete: Either threaded type or wedge type unless otherwise indicated; galvanized ferrous castings, either ASTM A47 malleable iron or ASTM A27 cast steel. Provide bolts, washers, and shims as needed, all hot-dip galvanized per ASTM F2329.
- F. Post-Installed Anchors: Torque-controlled expansion anchors or chemical anchors.
 - 1. Material for Interior Locations: Carbon-steel components zinc plated to comply with ASTM B633 or ASTM F1941, Class Fe/Zn 5, unless otherwise indicated.
 - 2. Material for Exterior Locations and Where Stainless Steel is Indicated: ASTM F593, Alloy Group 1 stainless steel bolts, and ASTM F594, Alloy Group 1 or 2 stainless steel nuts.
- G. Slotted-Channel Inserts: Cold-formed, hot-dip galvanized-steel box channels (struts) complying with MFMA-4, 1-5/8 by 7/8 inches by length indicated with anchor straps or studs not less than 3 inches long at not more than 8 inches on center. Provide with temporary filler and tee-head bolts, complete with washers and nuts, all zinc-plated to comply with ASTM B633, Class Fe/Zn 5, as needed for fastening to inserts.

2.4 MISCELLANEOUS MATERIALS

- A. Steel Primers:
 - 1. Provide primers that comply with Section 099000 – Painting and Coating.
 - 2. Universal Shop Primer: Fabricator's standard fast-curing, lead- and chromate-free, nonasphaltic, rust-inhibiting, primer complying with MPI #79 and compatible with topcoat.
 - a. Use primer containing pigments that make it easily distinguishable from zinc-rich primer.
 - 3. Water-Based Primer: Emulsion type, anticorrosive primer for mildly corrosive environments that is resistant to flash rusting when applied to cleaned steel, complying with MPI #107 and compatible with topcoat.
- B. Galvanized Steel Primer:
 - 1. Vinyl wash primer complying with MPI #80.
 - 2. Water-based galvanized metal primer complying with MPI #134.
 - 3. Etching Cleaner: MPI #25 for galvanized metal as specified in Section 099000.
- C. Shop Primer for Galvanized Steel: Primer formulated for exterior use over zinc-coated metal and compatible with finish paint systems indicated.
- A. Galvanizing Repair Coating: Zinc-rich, cold galvanizing compound complying with SSPC-Paint 20 or ASTM A780, and compatible with paints and coatings scheduled to be used over it.
 - 1. Products: Subject to compliance, provide one of the following:
 - a. Alvin Products; a div. of Dampney Co., Inc.: Galvax.
 - b. Rust-Oleum: 7000 System Cold Galvanizing Compound.
 - c. ITW Professional Brands; LPS: Cold Galvanize Corrosion INHIBITOR.
 - d. ZRC Worldwide: Galvilite.
 - e. Approved substitution.
 - 2. Zinc Content: Minimum 93 percent by weight.
 - 3. VOC Content: Maximum 385 g/L.
- B. Bituminous Paint: Cold-applied asphalt emulsion complying with ASTM D1187.

- C. Shrinkage-Resistant Grout: ASTM C1107, factory-packaged, nonmetallic, nonstaining, noncorrosive, nongaseous grout; recommended by manufacturer for interior and exterior applications.

2.5 FABRICATION, GENERAL

- A. Shop Assembly: Preassemble items in shop to greatest extent possible. Disassemble units only as necessary for shipping and handling limitations. Use connections that maintain structural value of joined pieces. Clearly mark units for reassembly and coordinated installation.
- B. Cut, drill, and punch metals cleanly and accurately. Remove burrs and ease edges to a radius of approximately 1/32 inch unless otherwise indicated. Remove sharp or rough areas on exposed surfaces.
- C. Form bent-metal corners to smallest radius possible without causing grain separation or otherwise impairing Work.
- D. Form exposed Work with accurate angles and surfaces and straight edges.
- E. Weld corners and seams continuously to comply with the following:
 - 1. Use materials and methods that minimize distortion and develop strength and corrosion resistance of base metals.
 - 2. Obtain fusion without undercut or overlap.
 - 3. Remove welding flux immediately.
 - 4. At exposed connections, finish exposed welds and surfaces smooth and blended so no roughness shows after finishing.
- F. Form exposed connections with hairline joints, flush and smooth, using concealed fasteners or welds where possible. Where exposed fasteners are required, use Phillips flat-head (countersunk) fasteners unless otherwise indicated. Locate joints where least conspicuous.
- G. Fabricate seams and other connections that are exposed to weather in a manner to exclude water. Provide weep holes where water may accumulate.
- H. Cut, reinforce, drill, and tap metal fabrications as indicated to receive finish hardware, screws, and similar items.
- I. Provide for anchorage of type indicated. Coordinate with supporting structure. Space anchoring devices to secure metal fabrications rigidly in place and to support indicated loads.
- J. Where units are indicated to be cast into concrete, equip with integrally welded steel strap anchors, 1/8 by 1-1/2 inches, with a minimum 6 inch embedment and 2 inch hook, not less than 8 inches from ends and corners of units and 24 inches on center, unless otherwise indicated.

2.6 MISCELLANEOUS FRAMING AND SUPPORTS

- A. Provide steel framing and supports not specified in other Sections as needed to complete Work.
- B. Fabricate units from steel shapes, plates, and bars of welded construction unless otherwise indicated. Fabricate to sizes, shapes, and profiles indicated and as necessary to receive adjacent construction.
 - 1. Furnish inserts for units installed after concrete is placed.
- C. Fabricate supports for operable partitions from continuous steel beams of sizes indicated or as recommended by partition manufacturer, with attached bearing plates, anchors, and braces as indicated or as recommended by partition manufacturer. Drill or punch bottom flanges of beams to receive partition track hanger rods; locate holes where indicated on operable partition Shop Drawings.

- D. Fabricate steel pipe columns for supporting wood frame construction from steel pipe with steel baseplates and top plates as indicated. Drill or punch baseplates and top plates for anchor and connection bolts and weld to pipe with fillet welds all around. Make welds the same size as pipe wall thickness unless otherwise indicated.
 - 1. Unless otherwise indicated, fabricate from Schedule 40 steel pipe.
 - 2. Unless otherwise indicated, provide 1/2-inch baseplates with four 5/8-inch anchor bolts and 1/4-inch top plates.
- E. Vanity Top Supports and Countertop Supports: 3/8 inch by 2 inch bent steel support supports as detailed. Pre-drill holes. Profile as indicated on Drawings. Prime paint finish.
- F. Flat Strap and Backing Plate: Steel sheet for blocking and bracing in length and width indicated.
 - 1. Minimum Base-Metal Thickness: 0.018 inch.
- G. Prime miscellaneous framing and supports with zinc-rich primer where indicated.

2.7 METAL LADDERS

- A. General:
 - 1. Comply with ANSI A14.3, except for elevator pit ladders.
 - 2. For elevator pit ladders, comply with ASME A17.1/CSA B44.
- B. Steel Elevator Pit Ladders:
 - 1. Space siderails 16 to 18 inches apart unless otherwise indicated.
 - 2. Siderails: Continuous, 3/8-by-2-1/2-inch steel flat bars, with eased edges.
 - 3. Rungs: 3/4 to 1-inch-diameter steel bars spaced 12 inches on center.
 - 4. Fit rungs in centerline of siderails; plug-weld and grind smooth on outer rail faces.
 - 5. Contractor's Option:
 - a. Provide nonslip surfaces on top of each rung, either by coating rung with aluminum-oxide granules set in epoxy-resin adhesive or by using type of manufactured rung filled with aluminum-oxide grout.
 - b. Provide nonslip surfaces on top of each rung by coating with abrasive material metallically bonded to rung.
 - 6. Support each ladder at top and bottom and not more than 60 inches on center with welded or bolted steel brackets unless indicated otherwise.
 - 7. Prime interior ladders, including brackets and fasteners, with primer specified in Section 099600 – High-Performance Coatings.

2.8 ELEVATOR PIT SUMP COVERS

- A. Fabricate from 1/8 inch rolled-steel floor plate with four 1 inch diameter holes for water drainage and for lifting.
- B. Provide steel angle supports as indicated.

2.9 MISCELLANEOUS STEEL TRIM

- A. Unless otherwise indicated, fabricate units from steel shapes, plates, and bars of profiles shown with continuously welded joints and smooth exposed edges. Miter corners and use concealed field splices where possible.
- B. Provide cutouts, fittings, and anchorages as needed to coordinate assembly and installation with other Work.
- C. Galvanize and prime exterior miscellaneous steel trim.

2.10 ABRASIVE METAL NOSINGS

- A. Extruded Units: Aluminum units with abrasive filler consisting of aluminum oxide, silicon carbide, or a combination of both, in an epoxy-resin binder. Fabricate units in lengths necessary to accurately fit openings or conditions.
 - 1. Recycled Content of Steel Products: Postconsumer recycled content plus 1/2 of preconsumer recycled content not less than 25 percent.
 - 2. Single Component Type-1: Ribbed abrasive units with embedment anchor; no nose.
 - a. Products: Subject to compliance with requirements, provide products from one of the following:
 - 1) American Safety Tread Company: 1211.
 - 2) Balco, Inc.: PC-150.
 - 3) Nystrom: Model STSB-N1.375E.
 - 4) Wooster Products, Inc.: Supergrit Type 610.
 - b. Size: Nominal 1-3/8 inch wide, 1/4 inch thick.
 - c. Locations: Poured concrete steps and precast concrete treads.
- B. Abrasive Filler Strip: 1/16 inch projection above aluminum extrusion.
 - 1. Filler Strip Color: Black.
- C. Provide units with integral anchors for embedding units in concrete.
 - 1. Embedment Anchor: Minimum 5/8 inch long.
- D. Apply clear lacquer to concealed surfaces of extruded units set into concrete.

2.11 LOOSE STEEL LINTELS

- A. Fabricate loose steel lintels from steel angles and shapes of size indicated for openings and recesses in masonry walls and partitions at locations indicated. Fabricate in single lengths for each opening unless otherwise indicated. Weld adjoining members together to form a single unit where indicated.
- B. Size loose lintels to provide bearing length at each side of openings equal to 1/12 of clear span, but not less than 8 inches unless otherwise indicated.
- C. Galvanize loose steel lintels located in exterior walls.

2.12 FINISHES, GENERAL

- A. Finish metal fabrications after assembly. Finish exposed surfaces to remove tool and die marks and stretch lines, and to blend into surrounding surface.

2.13 STEEL AND IRON FINISHES

- A. Galvanizing: Hot-dip galvanize items as indicated to comply with ASTM A153 for steel and iron hardware and with ASTM A123 for other steel and iron products.
 - 1. Do not quench or apply post galvanizing treatments that might interfere with paint adhesion.
- B. Preparation for Shop Priming Galvanized Items: After galvanizing, thoroughly clean railings of grease, dirt, oil, flux, and other foreign matter, and treat with metallic phosphate process.
- C. Shop prime iron and steel items not indicated to be galvanized unless they are to be embedded in concrete, sprayed-on fireproofing, or masonry, or unless otherwise indicated.
 - 1. Shop prime with universal shop primer unless zinc-rich primer is indicated.
- D. Preparation for Shop Priming: Prepare surfaces to comply with requirements indicated below:
 - 1. SSPC-SP 3: Interior Steel.
 - 2. SSPC-SP 6 (WAB)/NACE WAB-3: Exterior steel and steel indicated to receive high-performance coatings.

- E. Shop Priming: Apply shop primer to comply with SSPC-PA 1, "Paint Application Specification No. 1: Shop, Field, and Maintenance Painting of Steel," for shop painting.
 - 1. Stripe paint corners, crevices, bolts, welds, and sharp edges.

PART 3 - EXECUTION

3.1 INSTALLATION, GENERAL

- A. Cutting, Fitting, and Placement: Perform cutting, drilling, and fitting required for installing metal fabrications. Set metal fabrications accurately in location, alignment, and elevation; with edges and surfaces level, plumb, true, and free of rack; and measured from established lines and levels.
- B. Fit exposed connections accurately together to form hairline joints. Weld connections that are not to be left as exposed joints but cannot be shop welded because of shipping size limitations. Do not weld, cut, or abrade surfaces of exterior units that have been hot-dip galvanized after fabrication and are for bolted or screwed field connections.
- C. Field Welding: Comply with the following requirements:
 - 1. Use materials and methods that minimize distortion and develop strength and corrosion resistance of base metals.
 - 2. Obtain fusion without undercut or overlap.
 - 3. Remove welding flux immediately.
 - 4. At exposed connections, finish exposed welds and surfaces smooth and blended so no roughness shows after finishing and contour of welded surface matches that of adjacent surface.
- D. Fastening to In-Place Construction: Provide anchorage devices and fasteners where metal fabrications are required to be fastened to in-place construction. Provide threaded fasteners for use with concrete and masonry inserts, toggle bolts, through bolts, lag screws, wood screws, and other connectors.
- E. Provide temporary bracing or anchors in formwork for items that are to be built into concrete, masonry, or similar construction.
- F. Corrosion Protection: Coat concealed surfaces of aluminum that come into contact with grout, concrete, masonry, wood, or dissimilar metals with the following:
 - 1. Cast Aluminum: Heavy coat of bituminous paint.
 - 2. Extruded Aluminum: 2 coats of clear lacquer.

3.2 INSTALLATION OF MISCELLANEOUS FRAMING AND SUPPORTS

- A. General: Install framing and supports to comply with requirements of items being supported, including manufacturers' written instructions and requirements indicated on Shop Drawings.
- B. Anchor supports for operable partitions securely to, and rigidly brace from, building structure.
- C. Install pipe columns on concrete footings with grouted baseplates. Position and grout column baseplates as specified in "Installing Bearing and Leveling Plates" Article.
 - 1. Grout baseplates of columns supporting steel girders after girders are installed and leveled.

3.3 INSTALLATION OF NOSINGS

- A. Center nosings on tread widths unless otherwise indicated.
- B. For nosings embedded in concrete steps or curbs, align nosings flush with riser faces and level with tread surfaces.

3.4 REPAIR

- A. Galvanized Surfaces: Clean field welds, bolted connections, and abraded areas, and repair with galvanizing repair coating.
- B. Touchup Painting:
 - 1. Immediately after erection, clean field welds, bolted connections, and abraded areas. Paint uncoated and abraded areas with the same material as used for shop painting to comply with SSPC-PA 1 for touching up shop-painted surfaces.
 - a. Apply by brush or spray to provide a minimum 2.0-mil dry film thickness.
 - 2. Cleaning and touchup painting of field welds, bolted connections, and abraded areas of shop paint are specified in Section 099000 – Painting and Coating.

END OF SECTION 055000

SECTION 055213
PIPE AND TUBE RAILINGS

PART 1 - GENERAL

1.1 SUMMARY

- A. Section Includes:
1. Steel railings.
 2. Aluminum railings.
 3. Stainless-steel railings.

1.2 ADMINISTRATIVE REQUIREMENTS

- A. Coordination:
1. Coordinate selection of shop primers with topcoats to be applied over them. Comply with paint and coating manufacturers' written recommendations to ensure that shop primers and topcoats are compatible with one another.
 2. Coordinate installation of anchorages for railings. Furnish setting drawings, templates, and directions for installing anchorages, including sleeves, concrete inserts, anchor bolts, and items with integral anchors, that are to be embedded in concrete or masonry. Deliver such items to Project site in time for installation.
- B. Scheduling:
1. Schedule installation so wall attachments are made only to completed walls. Do not support railings temporarily by any means that do not satisfy structural performance requirements.

1.3 ACTION SUBMITTALS

- A. Product Data: For the following:
1. Manufacturer's product lines of mechanically connected railings.
 2. Railing brackets.
 3. Grout, anchoring cement, and paint products.
- B. Shop Drawings: Include plans, elevations, sections, details, and attachments to other Work.
- C. Samples: For each type of exposed finish required.
1. Sections of each distinctly different linear railing member, including handrails, top rails, posts, and balusters, including finish.
 2. Fittings and brackets.
 3. Assembled Sample of railing system, made from full-size components, including top rail, post, handrail, and infill. Sample need not be full height.
 - a. Show method of connecting and finishing members at intersections.
- D. Delegated-Design Submittal: For railings, including analysis data signed and sealed by qualified professional engineer responsible for their preparation.

1.4 INFORMATIONAL SUBMITTALS

- A. Qualification Data: For delegated-design professional engineer and testing agency.
- B. Welding certificates.
- C. Paint Compatibility Certificates: From manufacturers of topcoats applied over shop primers certifying that shop primers are compatible with topcoats.

- D. Product Test Reports: For pipe and tube railings, for tests performed by a qualified testing agency, according to ASTM E894 and ASTM E935.
- E. Evaluation Reports: For post-installed anchors, from ICC-ES or other qualified testing agency acceptable to authorities having jurisdiction.

1.5 QUALITY ASSURANCE

- A. Welding Qualifications: Qualify procedures and personnel according to the following:
 - 1. AWS D1.1, "Structural Welding Code - Steel."
 - 2. AWS D1.2, "Structural Welding Code - Aluminum."
 - 3. AWS D1.6, "Structural Welding Code - Stainless Steel."

1.6 DELIVERY, STORAGE, AND HANDLING

- A. Protect mechanical finishes on exposed surfaces from damage by applying a strippable, temporary protective covering before shipping.

1.7 FIELD CONDITIONS

- A. Field Measurements: Verify actual locations of walls and other construction contiguous with metal fabrications by field measurements before fabrication.

PART 2 - PRODUCTS

2.1 MANUFACTURERS

- A. Manufacturers: Subject to compliance with requirements, provide products by one of the following:

- 1. ~~Steel Pipe and Tube Railings:~~
 - a. ~~American Stair, Inc.:~~
 - b. ~~Ametco Manufacturing Corporation.~~
 - c. ~~R&B Wagner, Inc.~~
 - d. ~~VIVA Railings, LLC.~~
- 2. ~~Aluminum Pipe and Tube Railings:~~
 - a. ~~Ametco Manufacturing Corporation.~~
 - b. ~~Blum, Julius & Co., Inc.~~
 - c. ~~C.R. Laurence Co., Inc.~~
 - d. ~~CraneVeyor Corp. Hollaender Manufacturing Company.~~
 - f. ~~Kee Safety, Inc.~~
 - g. ~~Superior Aluminum Products, Inc.~~
 - h. ~~Tuttle Railing Systems; a Division of Tuttle Aluminum & Bronze, Inc.~~
 - i. ~~R&B Wagner, Inc.~~
 - j. ~~VIVA Railings, LLC.~~
- 3. ~~Stainless Steel Pipe and Tube Railings:~~
 - a. ~~Blum, Julius & Co., Inc.~~
 - b. ~~C.R. Laurence Co., Inc.~~
 - c. ~~Tuttle Railing Systems; a Division of Tuttle Aluminum & Bronze, Inc.~~
 - d. ~~R&B Wagner, Inc.~~
 - e. ~~VIVA Railings, LLC.~~

- B. Source Limitations: Obtain each type of railing from single source from single manufacturer.

2.2 PERFORMANCE CRITERIA

- A. Delegated Design: Engage a qualified professional engineer, as defined in Section 014000 – Quality Requirements, to design railings, including attachment to building construction.

- B. Structural Performance: Railings, including attachment to building construction, shall withstand effects of gravity loads and the following loads and stresses within limits and under conditions indicated:
 - 1. Handrails and Top Rails of Guards:
 - a. Uniform load of 50 lbf/ ft. applied in any direction.
 - b. Concentrated load of 200 lbf applied in any direction.
 - c. Uniform and concentrated loads need not be assumed to act concurrently.
 - 2. Infill of Guards:
 - a. Concentrated load of 50 lbf applied horizontally on an area of 1 sq. ft.
 - b. Infill load and other loads need not be assumed to act concurrently.
- C. Thermal Movements: Allow for thermal movements from ambient and surface temperature changes.
 - 1. Temperature Change: 120 deg F, ambient; 180 deg F, material surfaces.

2.3 METALS, GENERAL

- A. Metal Surfaces, General: Provide materials with smooth surfaces, without seam marks, roller marks, rolled trade names, stains, discolorations, or blemishes.
- B. Brackets, Flanges, and Anchors: Cast or formed metal of same type of material and finish as supported rails unless otherwise indicated.
 - 1. Provide type of bracket with flange tapped for concealed anchorage to threaded hanger bolt and that provides 1-1/2 inch clearance from inside face of handrail to finished wall surface.

2.4 STEEL RAILINGS

- A. Source Limitations: Obtain each type of railing from single source from single manufacturer.
- B. Tubing: ASTM A500 (cold formed) unless indicated otherwise.
- C. Pipe: ASTM A53, Type F or Type S, Grade A, Standard Weight (Schedule 40), unless another grade and weight are required by structural loads.
 - 1. Provide galvanized finish for exterior installations and where indicated.
- D. Plates, Shapes, and Bars: ASTM A36.
- E. Cast Iron Fittings: Either gray iron, ASTM A48, or malleable iron, ASTM A47, unless otherwise indicated.
- F. Expanded Metal Infill Panels: ASTM F1267, [**Type I (expanded)**] [**Type II (expanded and flattened)**], Class 1 (uncoated).
 - 1. Style Designation: [**3/4 number 13**] [**1-1/2 number 10**].
- G. Perforated Metal Infill Panels: Cold-rolled steel sheet, ASTM A1008, or hot-rolled steel sheet, ASTM A1011, commercial steel Type B.
 - 1. Product: Subject to compliance with requirements, provide products by one of the following:
 - a. Alabama Metal Industries Corporation; a Gibraltar Industries company.
 - b. Brown-Campbell Company.
 - c. McNichols Co.
 - d. NUCOR Grating; a Fisher & Ludlow Co.
 - 2. Thickness: 0.060 inch.
 - 3. Pattern: 1/4 inch holes 3/8 inch on center. in staggered rows.
- H. Perforated Meta Infill Panels: Galvanized-steel sheet, ASTM A653, G90 coating, commercial steel Type B.
 - 1. Product: Subject to compliance with requirements, provide products by one of the following:
 - a. Alabama Metal Industries Corporation; a Gibraltar Industries company.
 - b. Brown-Campbell Company.

- c. McNichols Co.
 - d. NUCOR Grating; a Fisher & Ludlow Co.
 - 2. Thickness: 0.064 inch.
 - 3. Pattern: 1/4 inch holes 3/8 inch on center. in staggered rows [**1/8 by 1 inch round end slotted holes in staggered rows**].
- I. Woven-Wire Mesh Infill Panels: Intermediate-crimp, [**diamond**] [**square**] pattern, 2 inch woven-wire mesh, made from 0.134 inch diameter wire complying with ASTM A510.

2.5 ALUMINUM RAILINGS

- A. Source Limitations: Obtain each type of railing from single source from single manufacturer.
- B. Aluminum, General: Provide alloy and temper recommended by aluminum producer and finisher for type of use and finish indicated, and with not less than strength and durability properties of alloy and temper designated below for each aluminum form required.
- C. Extruded [**Bars**] [**and**] [**Tubing**]: ASTM B221, Alloy 6063-T5/T52.
- D. Extruded Structural [**Pipe**] [**and**] [**Round Tubing**]: ASTM B429, Alloy 6063-T6.
 - 1. Provide Standard Weight (Schedule 40) pipe unless otherwise indicated.
- E. Drawn Seamless Tubing: ASTM B210, Alloy 6063-T832.
- F. Plate and Sheet: ASTM B209, Alloy 6061-T6.
- G. Die and Hand Forgings: ASTM B247, Alloy 6061-T6.
- H. Castings: ASTM B26, Alloy A356.0-T6.
- I. Perforated Metal Infill Panels: Aluminum sheet, ASTM B209, Alloy 3003 H-14.
 - 1. Product: Subject to compliance with requirements, provide product by one of the following:
 - a. Alabama Metal Industries Corporation; a Gibraltar Industries company.
 - b. Brown-Campbell Company.
 - c. McNichols Co.
 - d. NUCOR Grating; a Fisher & Ludlow Co.
 - 2. Description: Minimum solid margins both sides of sheet parallel to length of sheet. Shear holes through both ends of sheet parallel to width of sheet.
 - 3. Thickness: 0.050 inch.
 - 4. Perforations: 1/8 inch holes 3/16 inch on center. in staggered rows.
 - 5. Coverage: 32.6 holes/sq. in.
 - 6. Open Area: 40 percent.
 - 7. Bar Width: 1/16 inch.
- J. Woven-Wire Mesh Infill Panels: Intermediate-crimp, [**diamond**] [**square**] pattern, 2 inch woven-wire mesh, made from 0.162 inch diameter wire complying with ASTM B211, Alloy 6061-T94.

2.6 STAINLESS STEEL RAILINGS

- A. Tubing: ASTM A554, Grade MT 304.
- B. Pipe: ASTM A312, Grade TP 304.
- C. Castings: ASTM A743, Grade CF 8 or CF 20.
- D. Plate and Sheet: ASTM A240 or ASTM A666, Type 304.

- E. Expanded Metal Infill Panels: ASTM F1267, [**Type I (expanded)**] [**Type II (expanded and flattened)**], Class 3 (corrosion-resistant steel), made from stainless-steel sheet, ASTM A240 or ASTM A666, Type 304.
 - 1. Style Designation: [**3/4 number 13**] [**1-1/2 number 10**].
- F. Perforated Metal Infill Panels: Stainless-steel sheet, ASTM A240 or ASTM A666, Type 304, 0.062 inch thick, [**with 1/4 inch holes 3/8 inch on center. in staggered rows**].
 - 1. Basis-of-Design Product: Provide product with perforations matching [**product indicated on Drawings**].
- G. Woven-Wire Mesh: Intermediate-crimp, [**diamond**] [**square**] pattern, 2 inch woven-wire mesh, made from 0.141 inch diameter wire complying with ASTM A580, Type 304.
- H. Woven-Wire Mesh Infill Panels: Intermediate-crimp, made from 0.141 inch diameter wire complying with ASTM A580, Type 304.
 - 1. Product: Subject to compliance with requirements, provide specified product from McNichols Co. or approved substitution from one of the following:
 - a. Alabama Metal Industries Corporation; a Gibraltar Industries company.
 - b. Brown-Campbell Company.
 - c. NUCOR Grating; a Fisher & Ludlow Co.
 - 2. Product Line: Designer Metals.
 - 3. Designer Type: Designer Mesh.
 - 4. Construction: Designer Woven.
 - 5. Series Name AURA.
 - 6. Series Number: 8857.
 - 7. Weave Type: Triple shute, long way of opening (LWO) parallel to length of sheet,
 - 8. Thickness: 0.0595 inch.
 - 9. Coverage: 32.6 holes/sq. in.
 - 10. Open Area: 48 percent.

2.7 FASTENERS

- A. Fastener Materials:
 - 1. Ungalvanized-Steel Railings: Plated steel fasteners complying with ASTM F1941, Class Fe/Zn 5 for zinc coating.
 - 2. Hot-Dip Galvanized Railings: Type 304 stainless-steel or hot-dip zinc-coated steel fasteners complying with ASTM A153 or ASTM F2329 for zinc coating.
 - 3. [**Aluminum Railings: Type 304 stainless-steel fasteners.**]
 - 4. [**Stainless-Steel Railings: Type 304 stainless-steel fasteners.**]
 - 5. Finish exposed fasteners to match appearance, including color and texture, of railings.
- B. Fasteners for Anchoring Railings to Other Construction: Select fasteners of type, grade, and class required to produce connections suitable for anchoring railings to other types of construction indicated and capable of withstanding design loads.
- C. Fasteners for Interconnecting Railing Components:
 - 1. Provide concealed fasteners for interconnecting railing components and for attaching them to other Work, unless otherwise indicated.
 - 2. Provide concealed fasteners for interconnecting railing components and for attaching them to other Work, unless exposed fasteners are unavoidable or are the standard fastening method for railings indicated.
 - 3. Provide [**Phillips**] [**tamper-resistant**] [**square or hex socket**] flat-head machine screws for exposed fasteners unless otherwise indicated.
- D. Post-Installed Anchors: Fastener systems with working capacity greater than or equal to design load, according to an evaluation report acceptable to authorities having jurisdiction, based on ICC-ES AC193 or ICC-ES AC308.

1. Material for Interior Locations: Carbon-steel components zinc-plated to comply with ASTM B633 or ASTM F1941, Class Fe/Zn 5, unless otherwise indicated.
2. Material for Exterior Locations and Where Stainless Steel Is Indicated: Alloy Group 1 stainless-steel bolts, ASTM F593, and nuts, ASTM F594.

2.8 MISCELLANEOUS MATERIALS

- A. Handrail Brackets: **[Cast iron] [Cast aluminum,] [Cast stainless steel,] [Cast nickel-silver,]** center of handrail **[2-1/2 inches] [3-1/8 inches]** from **[face of railing] [wall]**.
- B. Welding Rods and Bare Electrodes: Select according to AWS specifications for metal alloy welded.
 1. For **[aluminum] [and] [stainless-steel]** railings, provide type and alloy as recommended by producer of metal to be welded and as required for color match, strength, and compatibility in fabricated items.
- C. Steel Primer:
 1. Comply with Section 099000 – Painting and Coating **[and] [Section 099600 – High-Performance Coatings]**.
 2. Fabricator's standard fast-curing, lead- and chromate-free, nonasphaltic, rust-inhibiting, primer complying with MPI #79 and compatible with topcoat.
 3. Use primer containing pigments that make it easily distinguishable from zinc-rich primer.
- D. Galvanized Steel Primer:
 1. Vinyl wash primer complying with MPI #80.
 2. Water-based galvanized metal primer complying with MPI #134.
 3. Etching Cleaner: MPI #25 for galvanized metal as specified in Section 099000.
- E. Galvanizing Repair Coating: Zinc-rich, cold galvanizing compound as specified in Section 055000 – Metal Fabrications.
- F. Intermediate Coats and Topcoats: Provide products that comply with Section 099000 – Painting and Coating **[and] [Section 099600 – High-Performance Coatings]**.
- G. Epoxy Intermediate Coat: Complying with MPI #77 and compatible with primer and topcoat.
- H. Polyurethane Topcoat: Complying with MPI #72 and compatible with undercoat.
- I. Bituminous Paint: Cold-applied asphalt emulsion complying with ASTM D1187.
- J. Nonmetallic, Shrinkage-Resistant Grout: ASTM C1107, factory-packaged, nonmetallic aggregate grout; recommended by manufacturer for interior and exterior applications; noncorrosive and nonstaining; mixed with water to consistency suitable for application and a 30 minute working time.
- K. Anchoring Cement: Factory-packaged, nonshrink, nonstaining, hydraulic-controlled expansion cement formulation for mixing with water at Project site to create pourable anchoring, patching, and grouting compound.
 1. Water-Resistant Product: At exterior locations and where indicated on Drawings, provide formulation that is resistant to erosion from water exposure without needing protection by a sealer or waterproof coating and that is recommended by manufacturer for exterior use.

2.9 FABRICATION

- A. General: Fabricate railings to comply with requirements indicated for design, dimensions, member sizes and spacing, details, finish, and anchorage, but not less than that required to support structural loads.
- B. Shop-assemble railings to greatest extent possible to minimize field splicing and assembly.
 1. Disassemble units only as necessary for shipping and handling limitations.

2. Clearly mark units for reassembly and coordinated installation.
 3. Use connections that maintain structural value of joined pieces.
- C. Cut, drill, and punch metals cleanly and accurately.
1. Remove burrs and ease edges to a radius of approximately 1/32 inch unless otherwise indicated.
 2. Remove sharp or rough areas on exposed surfaces.
- D. Form Work true to line and level with accurate angles and surfaces.
- E. Fabricate connections that are exposed to weather in a manner that excludes water.
1. Provide weep holes where water may accumulate.
 2. Locate weep holes in inconspicuous locations.
- F. Cut, reinforce, drill, and tap as indicated to receive finish hardware, screws, and similar items.
- G. Connections: Fabricate railings with welded connections unless otherwise indicated.
- H. Welded Connections: Cope components at connections to provide close fit, or use fittings designed for this purpose. Weld all around at connections, including at fittings.
1. Use materials and methods that minimize distortion and develop strength and corrosion resistance of base metals.
 2. Obtain fusion without undercut or overlap.
 3. Remove flux immediately.
 4. At exposed connections, finish exposed welds to comply with NOMMA's "Voluntary Joint Finish Standards" as follows:
 - a. **[Finish #1; with no evidence of a welded joint.]**
 - 1) **[Application: Architectural class stairs].**
 - b. Finish #2; completely sanded joint, some undercutting and pinholes okay.
 - c. Finish #2; completely sanded joint, some undercutting and pinholes okay.
 - 1) Application: Commercial class stairs.
 - d. Finish #3; partially dressed weld with spatter removed.
 - 1) Application: Service class stairs.
 - e. Finish #4; good quality, uniform undressed weld with minimal splatter.
 - 1) Application: Industrial class stairs.
- I. Welded Connections for Aluminum Pipe: Fabricate railings to interconnect members with concealed internal welds that eliminate surface grinding, using manufacturer's standard system of sleeve and socket fittings.
- J. Form changes in direction as follows:
1. Form rail-to-end post connections and changes in rail direction by radius bends, unless mitered corners are indicated.
 2. Form elbow and wall returns by bending or by inserting prefabricated elbow fittings.
 3. By bending to smallest radius that will not result in distortion of railing member.
- K. For changes in direction made by bending, use jigs to produce uniform curvature for each repetitive configuration required. Maintain cross section of member throughout entire bend without buckling, twisting, cracking, or otherwise deforming exposed surfaces of components.
- L. Close exposed ends of railing members with prefabricated end fittings.
- M. Provide wall returns at ends of wall-mounted handrails unless otherwise indicated. Close ends of returns unless clearance between end of rail and wall is 1/4 inch or less.
- N. Brackets, Flanges, Fittings, and Anchors: Provide wall brackets, flanges, miscellaneous fittings, and anchors to interconnect railing members to other Work unless otherwise indicated.

1. At brackets and fittings fastened to **[plaster]** **[or]** gypsum board partitions, provide crush-resistant fillers or other means to transfer loads through wall finishes to structural supports and prevent bracket or fitting rotation and crushing of substrate.
 - O. Provide inserts and other anchorage devices for connecting railings to concrete or masonry Work. Fabricate anchorage devices capable of withstanding loads imposed by railings. Coordinate anchorage devices with supporting structure.
 - P. For railing posts set in concrete, provide steel or stainless-steel sleeves not less than 6 inches long with inside dimensions not less than 1/2 inch greater than outside dimensions of post, with metal plate forming bottom closure.
 1. Provide sleeves of same material as railings.
 - Q. For removable railing posts, fabricate slip-fit sockets from **[steel]** **[stainless-steel]** tube or pipe whose ID is sized for a close fit with posts; limit movement of post without lateral load, measured at top, to not more than one-fortieth of post height. Provide socket covers designed and fabricated to resist being dislodged.
 1. **[Provide chain with eye, snap hook, and staple across gaps formed by removable railing sections at locations indicated. Fabricate from same metal as railings.]**
 - R. Expanded-Metal Infill Panels: Fabricate infill panels from expanded metal made from same metal as railings in which they are installed.
 1. Edge panels with U-shaped channels made from metal sheet, of same metal as expanded metal and not less than 0.043 inch thick.
 2. Orient expanded metal with long dimension of diamonds **[parallel to top rail]** **[perpendicular to top rail]** **[horizontal]** **[vertical]** **[as indicated on Drawings]**.
 - S. Perforated-Metal Infill Panels: Fabricate infill panels from perforated metal made from **[steel]** **[galvanized steel]** **[aluminum]** **[stainless steel]** **[same metal as railings in which they are installed]**.
 1. Edge panels with U-shaped channels made from metal sheet, of same metal as perforated metal and not less than 0.043 inch thick.
 2. Orient perforated metal with pattern as indicated on Drawings **[parallel to top rail]** **[perpendicular to top rail]** **[horizontal]** **[vertical]**.
 - T. Woven-Wire Mesh Infill Panels: Fabricate infill panels from woven-wire mesh crimped into 1 by 1/2 by 1/8 inch metal channel frames. Make wire mesh and frames from same metal as railings in which they are installed.
 1. Orient wire mesh with Orient wire mesh with as indicated on Drawings.
 2. Orient wire mesh with as indicated on Drawings.
 3. Orient wire mesh with **[diamonds vertical]** **[diamonds perpendicular to top rail]** **[wires perpendicular and parallel to top rail]** **[wires horizontal and vertical]**.
 - U. Toe Boards: Where indicated, provide toe boards at railings around openings and at edge of open-sided floors and platforms. Fabricate to dimensions and details indicated.
- 2.10 STEEL AND IRON FINISHES
- A. Galvanized Railings:
 1. Hot-dip galvanize exterior steel railings, including hardware, after fabrication.
 2. Comply with ASTM A123 for hot-dip galvanized railings.
 3. Comply with ASTM A153 for hot-dip galvanized hardware.
 4. Do not quench or apply post galvanizing treatments that might interfere with paint adhesion.
 5. Fill vent and drain holes that are exposed in the finished Work, unless indicated to remain as weep holes, by plugging with zinc solder and filing off smooth.

- B. For galvanized railings, provide hot-dip galvanized fittings, brackets, fasteners, sleeves, and other ferrous components.
- C. Preparing Galvanized Railings for Shop Priming: After galvanizing, thoroughly clean railings of grease, dirt, oil, flux, and other foreign matter, and treat with etching cleaner.
- D. For nongalvanized-steel railings, provide nongalvanized ferrous-metal fittings, brackets, fasteners, and sleeves; however, galvanize anchors to be embedded in exterior concrete or masonry.
- E. Preparation for Shop Priming: Prepare uncoated ferrous-metal surfaces to comply with requirements indicated below:
 - 1. SSPC-SP 3: Interior railings and guard rails.
 - 2. SSPC-SP 6 (WAB)/NACE WAB-3: Exterior railings and guard rails and railings and guard rails indicated to receive high-performance coatings.
- F. Primer Application: Apply shop primer to prepared surfaces of railings unless otherwise indicated. Comply with requirements in SSPC-PA 1, "Shop, Field, and Maintenance Painting of Steel," for shop painting. Primer need not be applied to surfaces to be embedded in concrete or masonry.
 - 1. Shop prime uncoated railings with universal shop primer unless zinc-rich primer or primers specified in Section 099600 – High-Performance Coatings are indicated.
 - 2. Do not apply primer to galvanized surfaces.
- G. Shop-Painted Finish: Comply with Section 099000 – Painting and Coating [and] [Section 099600 – High-Performance Coatings].
 - 1. Color: As selected by Architect from manufacturer's full range.
- H. High-Performance Coating: Apply epoxy intermediate and polyurethane topcoats to prime-coated surfaces. Comply with coating manufacturer's written instructions and with requirements in SSPC-PA 1, "Shop, Field, and Maintenance Painting of Steel," for shop painting. Apply at spreading rates recommended by coating manufacturer.
 - 1. Color: As selected by Architect from manufacturer's full range.

2.11 ALUMINUM FINISHES

- A. Appearance of Finished Work: Variations in appearance of abutting or adjacent pieces are acceptable if they are within 1/2 of range of approved Samples. Noticeable variations in same piece are unacceptable. Variations in appearance of other components are acceptable if they are within range of approved Samples and are assembled or installed to minimize contrast.
- B. Clear Anodic Finish: AAMA 611, AA-M12C22A41, Class I, 0.018 mm or thicker.
- C. Color Anodic Finish: AAMA 611, AA-M12C22A42/A44, Class I, 0.018 mm or thicker.
 - 1. Color: [Champagne] [Light bronze] [Medium bronze] [Dark bronze] [Black].
 - 2. Color: As selected by Architect from full range of industry colors and color densities.
- D. Baked-Enamel or Powder-Coat Finish: AAMA 2603 except with a minimum dry film thickness of 1.5 mils. Comply with coating manufacturer's written instructions for cleaning, conversion coating, and applying and baking finish.
 - 1. Color and Gloss: As selected by Architect from manufacturer's full range.
- E. Siliconized Polyester Finish: Epoxy primer and silicone-modified, polyester-enamel topcoat; with a dry film thickness of not less than 0.2 mil for primer and 0.8 mil for topcoat.
 - 1. Color and Gloss: As selected by Architect from manufacturer's full range.
- F. **[High-Performance Organic Finish: 2-coat fluoropolymer finish complying with AAMA 2605 and containing not less than 70 percent PVDF resin by weight in color coat. Prepare, pretreat, and apply coating to exposed metal surfaces to comply with coating and resin manufacturers' written instructions.]**

1. **[Color and Gloss: As selected by Architect from manufacturer's full range.]**

- G. Superior Performance Organic Finish, 3-Coat **[4-Coat]** PVDF: Fluoropolymer finish complying with AAMA 2605 and containing not less than 70 percent PVDF resin by weight in both color coat and clear topcoat. Prepare, pretreat, and apply coating to exposed metal surfaces to comply with coating and resin manufacturers' written instructions.

1. Color and Gloss: As selected by Architect from manufacturer's full range.

2.12 STAINLESS-STEEL FINISHES

- A. Surface Preparation: Remove tool and die marks and stretch lines, or blend into finish.
- B. Polished Finishes: Grind and polish surfaces to produce uniform finish, free of cross scratches.
1. Run grain with long dimension of each piece.
 2. When polishing is completed, passivate and rinse surfaces.
 3. Remove embedded foreign matter and leave surfaces chemically clean.
- C. Stainless Steel Pipe and Tubing Finishes:
1. 180-Grit Polished Finish: Uniform, directionally textured finish.
- D. Stainless Steel Sheet and Plate Finishes:
1. Directional Satin Finish: ASTM A480, No. 4.

PART 3 - EXECUTION

3.1 EXAMINATION

- A. Examine **[plaster] [and]** gypsum board assemblies, where reinforced to receive anchors, to verify that locations of concealed reinforcements are clearly marked for Installer. Locate reinforcements and mark locations if not already done.

3.2 INSTALLATION, GENERAL

- A. Perform cutting, drilling, and fitting required for installing railings.
1. Fit exposed connections together to form tight, hairline joints.
 2. Install railings level, plumb, square, true to line; without distortion, warp, or rack.
 3. Set railings accurately in location, alignment, and elevation; measured from established lines and levels.
 4. Do not weld, cut, or abrade surfaces of railing components that are coated or finished after fabrication and that are intended for field connection by mechanical or other means without further cutting or fitting.
 5. Set posts plumb within a tolerance of 1/16 inch in 3 feet.
 6. Align rails so variations from level for horizontal members and variations from parallel with rake of steps and ramps for sloping members do not exceed 1/4 **[1/16]** inch in 12 feet.
- B. Control of Corrosion: Prevent galvanic action and other forms of corrosion by insulating metals and other materials from direct contact with incompatible materials.
1. **[Coat concealed surfaces of aluminum that will be in contact with grout, concrete, masonry, wood, or dissimilar metals, with a heavy coat of bituminous paint.]**
- C. Adjust railings before anchoring to ensure matching alignment at abutting joints.
- D. Fastening to In-Place Construction: Use anchorage devices and fasteners where necessary for securing railings and for properly transferring loads to in-place construction.

3.3 RAILING CONNECTIONS

- A. Nonwelded Connections: Use mechanical or adhesive joints for permanently connecting railing components. Seal recessed holes of exposed locking screws using plastic cement filler colored to match finish of railings.
- B. Welded Connections: Use fully welded joints for permanently connecting railing components. Comply with requirements for welded connections in "Fabrication" Article whether welding is performed in shop or in the field.

3.4 ANCHORING POSTS

- A. Use stainless steel pipe sleeves preset and anchored into concrete for installing posts. After posts are inserted into sleeves, fill annular space between post and sleeve with nonshrink, nonmetallic grout or anchoring cement, mixed and placed to comply with anchoring material manufacturer's written instructions.
- B. **[Form or core-drill holes not less than 5 inches deep and 3/4 inch larger than OD of post for installing posts in concrete. Clean holes of loose material, insert posts, and fill annular space between post and concrete with [nonshrink, nonmetallic grout] [or] [anchoring cement], mixed and placed to comply with anchoring material manufacturer's written instructions.]**
- C. Cover anchorage joint with flange of same metal as post, welded to post after placing anchoring material.
- D. Anchor posts to metal surfaces with oval flanges, angle type, or floor type as required by conditions, connected to posts and to metal supporting members as follows:
 - 1. For steel pipe railings, weld flanges to post and bolt to metal supporting surfaces.
 - 2. **[For aluminum pipe railings, attach posts using fittings designed and engineered for this purpose.]**
 - 3. **[For stainless-steel pipe railings, weld flanges to post and bolt to supporting surfaces.]**
- E. **[Install removable railing sections, where indicated, in slip-fit metal sockets cast in concrete.]**

3.5 ATTACHING RAILINGS

- A. Anchor railing ends to concrete and masonry with flanges connected to **[brackets on underside of rails connected to]** railing ends and anchored to wall construction with anchors and bolts.
- B. Anchor railing ends to metal surfaces with flanges bolted to metal surfaces and welded to railing ends **[or] [connected to railing ends using nonwelded connections]**.
- C. Attach handrails to wall with wall brackets, except where end flanges are used. Provide brackets with 1-1/2 inch clearance from inside face of handrail and finished wall surface.
 - 1. Use type of bracket with **[flange tapped for concealed anchorage to threaded hanger bolt] [predrilled hole for exposed bolt anchorage]**.
 - 2. Locate brackets as indicated or, if not indicated, at spacing required to support structural loads.
- D. Secure wall brackets and railing end flanges to building construction as follows:
 - 1. Concrete and Solid Masonry Anchorage: Use drilled-in expansion shields and hanger or lag bolts.
 - 2. Hollow Masonry Anchorage: Use toggle bolts.
 - 3. **[Wood Stud Partitions: Use hanger or lag bolts set into studs or wood backing between studs. Coordinate with carpentry work to locate backing members.]**
 - 4. Steel-Framed Partitions: Use either of the following:
 - a. Self-tapping screws of size and type required to support structural loads, to fasten brackets directly to steel framing or concealed steel reinforcements.

- b. Toggle bolts installed through flanges of steel framing or through concealed steel reinforcements.

3.6 REPAIR

- A. Galvanized Surfaces: Clean field welds, bolted connections, and abraded areas, and repair with galvanizing repair coating.
- B. Touchup Painting:
 - 1. Immediately after erection, clean field welds, bolted connections, and abraded areas of shop paint, and paint exposed areas with same material as used for shop painting to comply with SSPC-PA 1 requirements for touching up shop-painted surfaces.
 - 2. Apply by brush or spray to provide a minimum 2.0 mil dry film thickness.
- C. Touchup Painting: Cleaning and touchup painting of field welds, bolted connections, and abraded areas of shop paint are specified in Section 099000 –Painting and Coating and Section 099600 – High Performance Coatings.

3.7 CLEANING

- A. Clean [**aluminum**] [**and**] [**stainless steel**] by washing thoroughly with clean water and soap and rinsing with clean water.

3.8 PROTECTION

- A. Protect finishes of railings from damage during construction period with temporary protective coverings approved by railing manufacturer. Remove protective coverings at time of Substantial Completion.
- B. Restore finishes damaged during installation and construction period, so no evidence remains of correction work. Return items that cannot be refinished in the field to the shop; make required alterations and refinish entire unit, or provide new units.

END OF SECTION 055213

SECTION 055313
BAR GRATINGS

PART 1 - GENERAL

1.1 SUMMARY

- A. Section Includes:
1. Metal bar gratings.
 2. Metal frames and supports for gratings.

1.2 ADMINISTRATIVE REQUIREMENTS

- A. Coordination:
1. Coordinate selection of shop primers with topcoats to be applied over them. Comply with paint and coating manufacturers' written recommendations to ensure that shop primers and topcoats are compatible with one another.
 2. Coordinate installation of anchorages for gratings, grating frames, and supports. Furnish setting drawings, templates, and directions for installing anchorages, including sleeves, concrete inserts, anchor bolts, and items with integral anchors, that are to be embedded in concrete or masonry. Deliver such items to Project site in time for installation.

1.3 ACTION SUBMITTALS

- A. Product Data: For the following:
1. Metal bar gratings.
 2. Clips and anchorage devices for gratings.
 3. Paint products.
- B. Shop Drawings: Include plans, sections, details, and attachments to other Work.
- C. Delegated-Design Submittal: For gratings, including manufacturer's published load tables and analysis data signed and sealed by qualified professional engineer responsible for their preparation.

1.4 INFORMATIONAL SUBMITTALS

- A. **[Mill Certificates: Signed by manufacturers of stainless steel certifying that products furnished comply with requirements.]**
- B. Welding certificates.
- C. Paint Compatibility Certificates: From manufacturers of topcoats applied over shop primers certifying that shop primers are compatible with topcoats.

1.5 QUALITY ASSURANCE

- A. Welding Qualifications: Qualify procedures and personnel per the following:
1. AWS D1.1, "Structural Welding Code - Steel."
 2. AWS D1.2, "Structural Welding Code - Aluminum."
 3. AWS D1.3, "Structural Welding Code - Sheet Steel."
 4. AWS D1.6, "Structural Welding Code - Stainless Steel."

1.6 FIELD CONDITIONS

- A. Field Measurements: Verify actual locations of walls and other construction contiguous with gratings by field measurements before fabrication.

PART 2 - PRODUCTS

2.1 MANUFACTURERS

- A. Manufacturers: Subject to compliance with requirements, provide products by one of the following:
 1. Brown-Campbell Company.
 2. Eaton.
 3. Grating Pacific, Inc.
 4. IKG.
 5. McNichols Co.
 6. Metalex, a Unit of Jason Incorporated.
 7. NUCOR Grating; a Fisher & Ludlow Co.
 8. SlipNOT Metal Safety Flooring, Division of WS Molnar Company.
 9. Approved substitution.

2.2 PERFORMANCE CRITERIA

- A. Delegated Design: Engage a qualified professional engineer, as defined in Section 014000 – Quality Requirements, to design gratings.
- B. Structural Performance: Gratings shall withstand effects of gravity loads and the following loads and stresses within limits and under conditions indicated.
 1. Floors: Uniform load of 125 lbf/sq. ft. or concentrated load of 2,000 lbf, whichever produces the greater stress.
 2. Floors: Uniform load of 250 lbf/sq. ft. or concentrated load of 3,000 lbf, whichever produces the greater stress.
 3. Walkways and Elevated Platforms Other Than Exits: Uniform load of 60 lbf/sq. ft.
 4. Walkways and Elevated Platforms Used as Exits: Uniform load of 100 lbf/sq. ft.
 5. Sidewalks and Vehicular Driveways, Subject to Trucking: Uniform load of 250 lbf/sq. ft. or concentrated load of 8,000 lbf, whichever produces the greater stress.
 6. Limit deflection to L/360 or 1/4 inch, whichever is less.
- C. Seismic Performance: Provide gratings capable of withstanding effects of earthquake motions determined per ASCE 7.
 1. Component Importance Factor: 1.5.

2.3 METAL BAR GRATINGS

- A. Metal Bar Grating Standards: Comply with NAAMM MBG 531, "Metal Bar Grating Manual."
- B. **Pressure-Locked Steel Grating**: Close mesh grating fabricated by pressing rectangular flush-top crossbars into slotted bearing bars.
 1. Bearing Bar Spacing: 7/16 inch on center.
 2. Bearing Bar Height: 1 inch.
 3. Bearing Bar Thickness: 3/16 inch.
 4. Crossbar Spacing: 4 inches on center.
 5. Percent Open Area: 55.
 6. Width: 36.inches.
 7. Traffic Surface: Plain.
 8. Steel Finish: Hot-dip galvanized with a coating weight of not less than 1.8 ounces per square foot of coated surface.

- C. Pressure-Locked Steel Grating: Fabricated by pressing rectangular, flush-top crossbars into slotted bearing bars swaging crossbars between bearing bars.
1. Bearing Bar Spacing: 7/16 or 1/2 inch [11/16 inch] [15/16 inch] [1-3/16 inches] on center.
 2. Bearing Bar Depth: 1-1/4 inches [1 inch] [1-1/2 inches] [1-3/4 inches] [2 inches] [2-1/4 inches] [2-1/2 inches] [As required to comply with structural performance requirements].
 3. Bearing Bar Thickness: 3/16 inch [1/8 inch] [1/4 inch] [As required to comply with structural performance requirements].
 4. Crossbar Spacing: 4 inches [2 inches] on center.
 5. Grating Mark P-11-4 (1 x 3/16) STEEL: 1-by-3/16 inch bearing bars at 11/16 inch on center, and crossbars at 4 inches on center.
 6. Grating Mark P-15-4 (1-1/4 x 1/8) STEEL: 1-1/4-by-1/8 inch bearing bars at 15/16 inch on center, and crossbars at 4 inches on center.
 7. Grating Mark P-19-4 (1-1/2 x 3/16) STEEL: 1-1/2-by-3/16 inch bearing bars at 1-3/16 inches on center, and crossbars at 4 inches on center.
 8. Grating Mark: As indicated.
 9. Traffic Surface: Plain [Serrate] [Knurled] [Applied abrasive finish consisting of aluminum-oxide aggregate in an epoxy-resin adhesive] [As indicated].
 10. Steel Finish:
 - a. Interior: Shop primed.
 - b. Exterior: Hot-dip galvanized with a coating weight of not less than 1.8 ounces per square foot of coated surface shop primed.
- D. Pressure-Locked, **Stainless-Steel** Grating: Fabricated by swaging crossbars between bearing bars pressing rectangular flush-top crossbars into slotted bearing bars.
1. Bearing Bar Spacing: [7/16 or 1/2 inch] [11/16 inch] [15/16 inch] [1-3/16 inches] [1-3/8 inches] [1-7/8 inches] [2-3/8 inches] on center.
 2. Bearing Bar Depth: [3/4 inch] [1 inch] [1-1/4 inches] [1-1/2 inches] [1-3/4 inches] [2 inches] [2-1/4 inches] [2-1/2 inches] [3 inches] [3-1/2 inches] [4 inches] [4-1/2 inches] [5 inches] [As required to comply with structural performance requirements].
 3. Bearing Bar Thickness: [1/8 inch] [3/16 inch] [1/4 inch] [3/8 inch] [As required to comply with structural performance requirements].
 4. Crossbar Spacing: [2 inches] [4 inches] on center.
 5. Grating Mark P-11-4 (1 x 3/16) STAINLESS STEEL: 1-by-3/16-inch bearing bars at 11/16 inch on center, and crossbars at 4 inches on center.
 6. Grating Mark P-15-2 (1 x 1/8) STAINLESS STEEL: 1-by-1/8-inch bearing bars at 15/16 inch on center, and crossbars at 2 inches on center.
 7. Grating Mark P-19-4 (1-1/2 x 3/16) STAINLESS STEEL: 1-1/2-by-3/16-inch bearing bars at 1-3/16 inches on center, and crossbars at 4 inches on center.
 8. Grating Mark P-30-4 (3 x 3/8) STAINLESS STEEL: 3-by-3/8-inch bearing bars at 1-7/8 inches on center, and crossbars at 4 inches on center.
 9. Grating Mark: As indicated.
 10. Traffic Surface: Plain Serrated Knurled Applied abrasive finish consisting of aluminum-oxide aggregate in an epoxy-resin adhesive.
- E. Pressure-Locked, Stainless-Steel Grating: Fabricated by swaging crossbars between bearing bars pressing rectangular flush-top crossbars into slotted bearing bars.
1. Basis-of-Design Product: Subject to compliance with requirements, provide Model Entec-58 SSS Clean Tread by Kadee Industries or approved substitution.
 2. Tread Material: Type 304 stainless steel, 3/32 inch by 3/16 inch.
 - a. **Standard Slot Opening: 5/321 inch.**
 3. Support Rods: Type 304 stainless steel, 1/2 inch rods spaced 2 inches on center.
 4. Directional Satin Finish: No. 4 finish.
 5. Frames: 304 stainless steel angle.
 6. Provide hidden locking devices to prevent warping and rattling.

- F. Pressure-Locked, Rectangular Bar Aluminum Grating: Fabricated by swaging crossbars between bearing bars pressing rectangular flush-top crossbars into slotted bearing bars.
1. Bearing Bar Spacing: **[7/16 or 1/2 inch] [11/16 inch] [15/16 inch] [1-3/16 inches]** on center.
 2. Bearing Bar Depth: **[1 inch] [1-1/4 inches] [1-1/2 inches] [1-3/4 inches] [2 inches] [2-1/4 inches] [2-1/2 inches] [As required to comply with structural performance requirements]**.
 3. Bearing Bar Thickness: **[1/8 inch] [3/16 inch] [1/4 inch] [As required to comply with structural performance requirements]**.
 4. Crossbar Spacing: **[2 inches] [4 inches]** on center.
 5. Grating Mark P-7-4 (1 x 1/8) ALUMINUM: 1-by-1/8 inch bearing bars at 7/16 inch on center, and crossbars at 4 inches on center.
 6. Grating Mark P-11-4 (1 x 3/16) ALUMINUM: 1-by-3/16 inch bearing bars at 11/16 inch on center, and crossbars at 4 inches on center.
 7. Grating Mark P-15-4 (1-1/2 x 3/16) ALUMINUM: 1-1/2-by-3/16 inch bearing bars at 15/16 inch on center, and crossbars at 4 inches on center.
 8. Grating Mark P-19-4 (2 x 3/16) ALUMINUM: 2-by-3/16 inch bearing bars at 1-3/16 inches on center, and crossbars at 4 inches on center.
 9. Grating Mark: As indicated.
 10. Traffic Surface: Plain Applied abrasive finish consisting of aluminum-oxide aggregate in an epoxy-resin adhesive.
 11. Aluminum Finish: Mill finish Class I, clear, anodized finish.
- G. Pressure-Locked, Aluminum I-Bar Grating: Fabricated by swaging crossbars between bearing bars.
1. Bearing Bar Spacing: **[7/16 or 1/2 inch] [11/16 inch] [15/16 inch] [1-3/16 inches]** on center.
 2. Bearing Bar Depth: **[1 inch] [1-1/4 inches] [1-1/2 inches] [1-3/4 inches] [2 inches] [2-1/4 inches] [2-1/2 inches] [As required to comply with structural performance requirements]**.
 3. Bearing Bar Flange Width: 1/4 inch.
 4. Crossbar Spacing: **[2 inches] [4 inches]** on center.
 5. Grating Mark P-11-4 (1 I-Bar) ALUMINUM: 1 inch I-bar bearing bars at 11/16 inch on center, and crossbars at 4 inches on center.
 6. Grating Mark P-15-2 (1 I-Bar) ALUMINUM: 1 inch I-bar bearing bars at 15/16 inch on center, and crossbars at 2 inches on center.
 7. Grating Mark P-19-4 (1-1/2 I-Bar) ALUMINUM: 1-1/2 inch I-bar bearing bars at 1-3/16 inches on center, and crossbars at 4 inches on center.
 8. Grating Mark: As indicated.
 9. Traffic Surface: Plain Applied abrasive finish consisting of aluminum-oxide aggregate in an epoxy-resin adhesive.
 10. Aluminum Finish: Mill finish Class I, clear, anodized finish.
- H. **[Welded Steel Grating:]**
1. Bearing Bar Spacing: **[7/16 or 1/2 inch] [11/16 inch] [15/16 inch] [1-3/16 inches] [1-3/8 inches] [1-7/8 inches] [2-3/8 inches]** on center.
 2. Bearing Bar Depth: **[3/4 inch] [1 inch] [1-1/4 inches] [1-1/2 inches] [1-3/4 inches] [2 inches] [2-1/4 inches] [2-1/2 inches] [3 inches] [3-1/2 inches] [4 inches] [4-1/2 inches] [5 inches] [As required to comply with structural performance requirements]**.
 3. Bearing Bar Thickness: **[1/8 inch] [3/16 inch] [1/4 inch] [3/8 inch] [As required to comply with structural performance requirements]**.
 4. Crossbar Spacing: **[2 inches] [4 inches]** on center.
 5. Grating Mark W-11-4 (1 x 3/16) STEEL: 1-by-3/16-inch bearing bars at 11/16 inch on center, and crossbars at 4 inches on center.
 6. Grating Mark W-15-4 (1 x 1/8) STEEL: 1-by-1/8-inch bearing bars at 15/16 inch on center, and crossbars at 4 inches on center.
 7. Grating Mark W-19-4 (1-1/4 x 3/16) STEEL: 1-1/4-by-3/16-inch bearing bars at 1-3/16 inches on center, and crossbars at 4 inches on center

8. Grating Mark W-19-4 (1-1/2 x 3/16) STEEL: 1-1/2-by-3/16-inch bearing bars at 1-3/16 inches on center, and crossbars at 4 inches on center.
9. Grating Mark W-19-4 (2 x 1/4) STEEL: 2-by-1/4-inch bearing bars at 1-3/16 inches on center, and crossbars at 4 inches on center.
10. Grating Mark W-30-4 (5 x 3/8) STEEL: 5-by-3/8-inch bearing bars at 1-7/8 inches on center, and crossbars at 4 inches on center.
11. Grating Mark: As indicated.
12. Traffic Surface: Serrated **[Plain] [Knurled] [Applied abrasive finish consisting of aluminum-oxide aggregate in an epoxy-resin adhesive] [As indicated].**
13. Steel Finish:
 - a. Interior: Shop primed.
 - b. Exterior: Hot-dip galvanized with a coating weight of not less than 1.8 ounces per square foot of coated surface shop primed.

2.4 FERROUS METALS

- A. Recycled Content of Steel Products: Postconsumer recycled content plus 1/2 of preconsumer recycled content not less than 25 percent.
- B. Steel Plates, Shapes, and Bars: ASTM A36.
- C. Steel Bars for Bar Gratings: ASTM A36 or steel strip, ASTM A1011 or ASTM A1018.
- D. Wire Rod for Bar Grating Crossbars: ASTM A510.
- E. Uncoated Steel Sheet: ASTM A1011, structural steel, Grade 30.
- F. Galvanized-Steel Sheet: ASTM A653, structural quality, Grade 33, with G90 coating.
- G. **[Stainless-Steel Sheet, Strip, Plate, and Flat Bars: ASTM A240, Type 304.]**
- H. **[Stainless-Steel Bars and Shapes: ASTM A276, Type 304.]**

2.5 ALUMINUM

- A. Provide alloy and temper recommended by aluminum producer and finisher for type of use indicated, and with not less than strength and durability properties of alloy and temper designated below for each aluminum form required.
- B. Extruded Bars and Shapes: ASTM B221, alloys as follows:
 1. 6061-T6 or 6063-T6, for bearing bars of gratings and shapes.
 2. 6061-T1, for grating crossbars.
- C. **[Aluminum Sheet: ASTM B209, Alloy 5052-H32.]**

2.6 FASTENERS

- A. General: Unless otherwise indicated, provide Type 304 stainless-steel fasteners for exterior use and zinc-plated fasteners with coating complying with ASTM B633 or ASTM F1941, Class Fe/Zn 5, at exterior walls. Select fasteners for type, grade, and class required.
 1. Provide stainless-steel fasteners for fastening aluminum.
 2. Provide stainless steel fasteners for fastening stainless steel.
- B. Steel Bolts and Nuts: Regular hexagon-head bolts, ASTM A307, Grade A; with hex nuts, ASTM A563; and, where indicated, flat washers.
- C. Stainless-Steel Bolts and Nuts: Regular hexagon-head annealed stainless-steel bolts, nuts, and, where indicated, flat washers; ASTM F593 for bolts and ASTM F594 for nuts, Alloy Group 1.

- D. Anchor Bolts: ASTM F1554, Grade 36, of dimensions indicated; with nuts, ASTM A563; and, where indicated, flat washers.
 - 1. Hot-dip galvanize or provide mechanically deposited, zinc coating where item being fastened is indicated to be galvanized.
- E. Post-Installed Anchors: Torque-controlled expansion anchors or chemical anchors capable of sustaining, without failure, a load equal to 4 times load imposed when installed in concrete [**and 6 times load imposed when installed in unit masonry**], as determined by testing according to ASTM E488, conducted by a qualified independent testing agency.
 - 1. Material for **Interior** Locations: Carbon-steel components zinc plated to comply with ASTM B633 or ASTM F1941, Class Fe/Zn 5, unless otherwise indicated.
 - 2. Material for **Exterior** Locations and Where Stainless Steel is Indicated: Alloy Group 1 stainless-steel bolts, ASTM F593, and nuts, ASTM F594.

2.7 MISCELLANEOUS MATERIALS

- A. Steel Primer:
 - 1. Comply with Section 099000 – Painting and Coating [**and**] [**Section 099600 – High-Performance Coatings**].
 - 2. Fabricator's standard fast-curing, lead- and chromate-free, nonasphaltic, rust-inhibiting, primer complying with MPI #79 and compatible with topcoat.
 - 3. Use primer containing pigments that make it easily distinguishable from zinc-rich primer.
- B. Galvanized Steel Primer:
 - 1. Vinyl wash primer complying with MPI #80.
 - 2. Water-based galvanized metal primer complying with MPI #134.
 - 3. Etching Cleaner: MPI #25 for galvanized metal as specified in Section 099000.
- C. Galvanizing Repair Coating: Zinc-rich, cold galvanizing compound as specified in Section 055000 – Metal Fabrications.
- D. Bituminous Paint: Cold-applied asphalt emulsion complying with ASTM D1187.

2.8 FABRICATION

- A. Shop Assembly: Fabricate grating sections in shop to greatest extent possible to minimize field splicing and assembly. Disassemble units only as necessary for shipping and handling limitations. Use connections that maintain structural value of joined pieces. Clearly mark units for reassembly and coordinated installation.
- B. Cut, drill, and punch material cleanly and accurately. Remove burrs and ease edges to a radius of approximately 1/32 inch unless otherwise indicated. Remove sharp or rough areas on exposed surfaces.
- C. Form from materials of size, thickness, and shapes indicated, but not less than that needed to support indicated loads.
- D. Fit exposed connections accurately together to form hairline joints.
- E. Welding: Comply with AWS recommendations and the following:
 - 1. Use materials and methods that minimize distortion and develop strength and corrosion resistance of base metals.
 - 2. Obtain fusion without undercut or overlap.
 - 3. Remove welding flux immediately.
- F. Provide for anchorage of type indicated; coordinate with supporting structure. Fabricate and space anchoring devices to secure gratings, frames, and supports rigidly in place and to support indicated loads.

1. Fabricate toeplates to fit grating units and weld to units in shop unless attaching in field is indicated.
 2. Toeplate Height: 4 inches unless otherwise indicated.
- G. Removable Grating Sections: Fabricate with banding bars attached by welding to entire perimeter of each section. Include anchors and fasteners of type indicated or, if not indicated, as recommended by manufacturer for attaching to supports.
1. **[Provide no fewer than 4 weld lugs for each heavy-duty grating section, with each lug shop welded to 2 bearing bars.]**
 2. **[Provide no fewer than 4 saddle clips for each grating section composed of rectangular bearing bars 3/16 inch or less in thickness and spaced 15/16 inch or more on center, with each clip designed and fabricated to fit over 2 bearing bars.]**
 3. Provide no fewer than 4 weld lugs for each grating section composed of rectangular bearing bars 3/16 inch or less in thickness and spaced less than 15/16 inch on center, with each lug shop welded to 3 or more bearing bars. Interrupt intermediate bearing bars as necessary for fasteners securing grating to supports.
 4. **[Provide no fewer than 4 flange blocks for each section of aluminum I-bar grating, with block designed to fit over lower flange of I-shaped bearing bars.]**
 5. Furnish threaded bolts with nuts and washers for securing grating to supports.
 6. Furnish self-drilling fasteners with washers for securing grating to supports.
 7. Furnish galvanized malleable-iron flange clamp with galvanized bolt for securing grating to supports. Furnish as a system designed to be installed from above grating by one person.
 - a. Products: Subject to compliance with requirements, provide one of the following:
 - 1) Grating Fasteners, LLC: G-Clip Series.
 - 2) Kee Safety, Inc.: Grating Clip.
 - 3) LNA Solutions, a Kee Safety company: Grate-Fix or GF Grate-Fast.
 - 4) McNichols Co.: Grating Fastener.
 - 5) Approved substitution.
- H. Fabricate cutouts in grating sections for penetrations indicated.
1. Edge-band openings in grating that interrupt 4 or more bearing bars with bars of same size and material as bearing bars.
 2. Arrange cutouts to permit grating removal without disturbing items penetrating gratings.
- I. Do not notch bearing bars at supports to maintain elevation.

2.9 GRATING FRAMES AND SUPPORTS

A. Frames and Supports:

1. Fabricate from metal shapes, plates, and bars of welded construction to sizes, shapes, and profiles indicated and as necessary to receive gratings.
2. Miter and weld connections for perimeter angle frames.
3. Cut, drill, and tap units to receive hardware and similar items.
4. Unless otherwise indicated, fabricate from same basic metal as gratings.
5. Equip units indicated to be cast into concrete or built into masonry with integrally welded anchors. Unless otherwise indicated, space anchors 24 inches on center and provide minimum anchor units in form of steel straps 1-1/4 inches wide by 1/4 inch thick by 8 inches long.

B. Galvanize steel frames and supports in the following locations:

1. Exterior.
2. Interior, where indicated.

2.10 [ALUMINUM FINISHES]

A. [Clear Anodic Finish: AAMA 611, AA-M12C22A41, Class I.]

2.11 STEEL FINISHES

- A. Finish gratings, frames, and supports after assembly.
- B. Galvanizing: Hot-dip galvanize items as indicated to comply with ASTM A153 for steel and iron hardware and with ASTM A123 for other steel and iron products.
 - 1. Do not quench or apply post galvanizing treatments that might interfere with paint adhesion.
- C. Preparation for Shop Priming Galvanized Items: After galvanizing, thoroughly clean railings of grease, dirt, oil, flux, and other foreign matter, and treat with metallic phosphate process.
- D. Shop prime gratings, frames, and supports not indicated to be galvanized unless otherwise indicated.
 - 1. Shop prime with universal shop primer unless zinc-rich primer or primers specified in Section 099600 – High-Performance Coatings are indicated.
- E. Preparation for Shop Priming: Prepare surfaces to comply with requirements indicated below:
 - 1. SSPC-SP 3: Interior Steel.
 - 2. SSPC-SP 6 (WAB)/NACE WAB-3: Exterior steel and steel indicated to receive high-performance coatings.
- F. Shop Priming: Apply shop primer to comply with SSPC-PA 1, "Paint Application Specification No. 1: Shop, Field, and Maintenance Painting of Steel," for shop painting.
 - 1. Stripe paint corners, crevices, bolts, welds, and sharp edges.

PART 3 - EXECUTION

3.1 INSTALLATION, GENERAL

- A. Fastening to In-Place Construction: Provide anchorage devices and fasteners where necessary for securing gratings to in-place construction. Include threaded fasteners for concrete and masonry inserts, through-bolts, lag bolts, and other connectors.
- B. Cutting, Fitting, and Placement: Perform cutting, drilling, and fitting required for installing gratings. Set units accurately in location, alignment, and elevation; measured from established lines and levels and free of rack.
- C. Provide temporary bracing or anchors in formwork for items that are to be built into concrete or masonry.
- D. Fit exposed connections accurately together to form hairline joints.
 - 1. Weld connections that are not to be left as exposed joints but cannot be shop welded because of shipping size limitations. Do not weld, cut, or abrade the surfaces of exterior units that have been hot-dip galvanized after fabrication and are for bolted or screwed field connections.
- E. Attach toeplates to gratings by welding at locations indicated.
- F. Field Welding: Comply with AWS recommendations and the following:
 - 1. Use materials and methods that minimize distortion and develop strength and corrosion resistance of base metals.
 - 2. Obtain fusion without undercut or overlap.
 - 3. Remove welding flux immediately.
- G. Corrosion Protection: Coat concealed surfaces of aluminum that will come into contact with grout, concrete, masonry, wood, or dissimilar metals, with a heavy coat of bituminous paint.

3.2 INSTALLING METAL BAR GRATINGS

- A. General: Install gratings to comply with recommendations of referenced metal bar grating standards that apply to grating types and bar sizes indicated, including installation clearances and standard anchoring details.
- B. **[Attach removable units to supporting members with type and size of clips and fasteners indicated or, if not indicated, as recommended by grating manufacturer for type of installation conditions shown.]**
- C. Attach nonremovable units to supporting members by welding where both materials are same; otherwise, fasten by bolting as indicated above.

3.3 REPAIR

- A. Galvanized Surfaces: Clean field welds, bolted connections, and abraded areas, and repair with galvanizing repair coating.
- B. Touchup Painting: Cleaning and touchup painting of field welds, bolted connections, and abraded areas of shop paint are specified in Section 099600 – High Performance Coatings.

END OF SECTION 055313

SECTION 061000
ROUGH CARPENTRY

PART 1 - GENERAL

1.1 SUMMARY

- A. Section Includes:
1. Framing with dimension lumber.
 2. Framing with engineered wood products.
 3. Shear wall panels.
 4. Rooftop equipment bases and support curbs.
 5. Wood blocking and nailers.
 6. Wood furring.
 7. Wood sleepers.
 8. Plywood backing panels.

1.2 ACTION SUBMITTALS

- A. Product Data: For each type of process and factory-fabricated product.
1. Indicate component materials and dimensions.
 2. Include construction and application details.
 3. Include data for wood-preserved treatment from chemical treatment manufacturer and certification by treating plant that treated materials comply with requirements. Indicate type of preservative used and net amount of preservative retained.
 4. Include data for fire-retardant treatment from chemical treatment manufacturer and certification by treating plant that treated materials comply with requirements. Include physical properties of treated materials based on testing by a qualified independent testing agency.
 5. For fire-retardant treatments, include physical properties of treated lumber both before and after exposure to elevated temperatures, based on testing by a qualified independent testing agency according to ASTM D5664.
 6. For products receiving a waterborne treatment, include statement that moisture content of treated materials was reduced to levels specified before shipment to Project site.
- B. Sustainable Design Submittals:
1. Environmental Product Declaration (EPD): For each product.
 2. Chain-of-Custody Certificates: For certified wood products. Include statement of costs.
 3. Chain-of-Custody Qualification Data: For manufacturer and vendor.
 4. Laboratory Test Reports: For composite wood products, indicating compliance with requirements for low-emitting materials.
 5. Product Data: For installation adhesives, indicating VOC content.
 6. Laboratory Test Reports: For installation adhesives, indicating compliance with requirements for low-emitting materials.
- C. Fastener Patterns: Full-size templates for fasteners in exposed framing.

1.3 INFORMATIONAL SUBMITTALS

- A. Evaluation Reports: For the following, from ICC-ES:
1. Preservative-treated and fire-retardant-treated wood products.
 2. Engineered wood products.
 3. Shear wall panels.
 4. Power-driven fasteners.
 5. Post-installed and metal framing anchors.

- B. Certificates of Inspection: Issued by lumber grading agency for exposed wood products not marked with grade stamp.

1.4 QUALITY ASSURANCE

- A. Testing Agency Qualifications: For testing agency providing classification marking for fire-retardant treated material, an inspection agency acceptable to authorities having jurisdiction that periodically performs inspections to verify that materials bearing classification marking is representative of material tested.
- B. Manufacturer Qualifications: A qualified manufacturer that is certified for chain of custody by an FSC-accredited certification body.
- C. Vendor Qualifications: A vendor that is certified for chain of custody by an FSC-accredited certification body.

1.5 DELIVERY, STORAGE, AND HANDLING

- A. Store materials under cover and protected from weather and contact with damp or wet surfaces. Stack lumber flat with spacers between each bundle to provide air circulation. Provide for air circulation around stacks and under coverings.

PART 2 - PRODUCTS

2.1 WOOD PRODUCTS, GENERAL

- A. Certified Wood: The following wood products shall be certified as "FSC Pure" according to FSC STD-01-001 and FSC STD-40-004.
- B. Comply with DOC PS 20 and with applicable rules of grading agencies indicated. If no grading agency is indicated, comply with applicable rules of any rules-writing agency certified by ALSC Board of Review. Grade lumber by an agency certified by ALSC Board of Review to inspect and grade lumber under the rules indicated.
 - 1. Factory mark each piece of lumber with grade stamp of grading agency.
 - 2. For exposed lumber indicated to receive a stained or natural finish, mark grade stamp on end or back of each piece or omit grade stamp and provide certificates of grade compliance issued by grading agency.
 - 3. Dress lumber, S4S, unless otherwise indicated.
- C. Maximum Moisture Content of Lumber: As indicated on structural Drawings.
- D. Engineered Wood Products: Acceptable to authorities having jurisdiction and for which current model code research or evaluation reports exist that show compliance with building code in effect for Project.
 - 1. Allowable design stresses, as published by manufacturer, shall meet or exceed those indicated. Manufacturer's published values shall be determined from empirical data or by rational engineering analysis and demonstrated by comprehensive testing performed by a qualified independent testing agency.
- E. Lumber fabricated from old growth timber is not permitted

2.2 WOOD-PRESERVATIVE-TREATED MATERIALS

- A. Manufacturers: Subject to compliance with requirements, provide wood-preservative-treatment products from one of the following:
 - 1. Hoover Treated Wood Products, Inc.
 - 2. Koppers Performance Chemicals.

3. Lonza.
 4. Viance – Treated Wood Solutions.
 5. Approved substitutions.
- B. Preservative Treatment by Pressure Process: AWWPA U1 Use Categories as follows:
1. UC2: Interior lumber not in contact with ground but may be subject to dampness.
 2. UC3B: Exterior lumber not in contact with ground.
 3. UC4A: Exterior lumber in contact with ground.
- C. Preservative Chemicals: Acceptable to authorities having jurisdiction.
1. Do not use chemicals containing arsenic or chromium except as approved by AHJ for timber posts.
 2. For exposed items indicated to receive a stained or natural finish, chemical formulations shall not require incising, contain colorants, bleed through, or otherwise adversely affect finishes.
- D. Kiln-dry lumber after treatment to a maximum moisture content of 19 percent. Do not use material that is warped or that does not comply with requirements for untreated material.
- E. Mark lumber with treatment quality mark of an inspection agency approved by ALSC Board of Review.
1. For exposed lumber indicated to receive stained or natural finish, mark end or back of each piece, or omit marking and provide certificates of treatment compliance issued by inspection agency if acceptable to inspection agency or authorities having jurisdiction.
- F. Application: Treat items indicated on Drawings, and the following:
1. Wood nailers, curbs, equipment support bases, blocking, stripping, and similar members in connection with roofing, flashing, vapor barriers, and waterproofing.
 2. Wood sills, sleepers, blocking, furring, and similar concealed members in contact with masonry or concrete.
 3. Wood framing and furring attached directly to interior of below-grade exterior masonry or concrete walls.
 4. Wood floor plates that are installed over concrete slabs-on-grade.

2.3 FIRE-RETARDANT-TREATED MATERIALS

- A. Manufacturers: Subject to compliance with requirements, provide fire-retardant-treatment from one of the following:
1. Hoover Treated Wood Products, Inc.
 2. Koppers Performance Chemicals.
 3. Lonza.
 4. Viance – Treated Wood Solutions.
 5. Approved substitutions.
- B. Where fire-retardant-treated materials are indicated, materials shall comply with requirements in this Article, that are acceptable to authorities having jurisdiction, and with fire-test-response characteristics specified as determined by testing identical products per test method indicated by a qualified testing agency.
- C. Fire-Retardant-Treated Lumber and Plywood by Pressure Process: Products with a flame-spread index of 25 or less when tested according to ASTM E84, and with no evidence of significant progressive combustion when the test is extended an additional 20 minutes, and with flame front not extending more than 10.5 feet beyond centerline of burners at any time during the test.
1. Treatment shall not promote corrosion of metal fasteners.
 2. Exterior Type: Treated materials shall comply with requirements specified above for fire-retardant-treated lumber and plywood by pressure process after being subjected to accelerated weathering according to ASTM D2898.
 - a. Application: Exterior locations and where indicated.

3. Interior Type A: Treated materials shall have a moisture content of 28 percent or less when tested according to ASTM D3201 at 92 percent relative humidity.
 - a. Application: Where exterior type is not indicated.
 4. Design Value Adjustment Factors: Treated lumber shall be tested according to ASTM D5664 and design value adjustment factors shall be calculated according to ASTM D6841. For enclosed roof framing, framing in attic spaces, and where high temperature fire-retardant treatment is indicated, provide material with adjustment factors of not less than 0.85 modulus of elasticity and 0.75 for extreme fiber in bending for Project's climatological zone.
- D. Kiln-dry lumber after treatment to maximum moisture content of 19 percent. Kiln-dry plywood backing panels after treatment to maximum moisture content of 15 percent.
- E. Identify fire-retardant-treated wood with appropriate classification marking of qualified testing agency.
 1. For exposed lumber indicated to receive stained or natural finish, mark end or back of each piece. Omit marking and provide certificates of treatment compliance issued by inspection agency if acceptable to local jurisdiction.
- F. For exposed items indicated to receive a stained or natural finish, chemical formulations shall not bleed through, contain colorants, or otherwise adversely affect finishes.
- G. Application: Treat items indicated on Drawings.
- 2.4 DIMENSION LUMBER FRAMING
- A. Non-Load-Bearing Interior Partitions: Construction or No. 2 grade.
 1. Species:
 - a. Hem-fir; WCLIB, or WWPA.
 - b. Western woods; WCLIB or WWPA.
 2. Application: Interior, non-load-bearing partitions.
- B. Load-Bearing Partitions: As indicated on structural Drawings.
- C. Joists, Rafters, and Other Framing Not Listed Above: As indicated on structural Drawings.
- 2.5 TIMBER FRAMING
- A. Comply with the following requirements, according to grading rules of grading agency indicated:
 1. Species and Grade: As indicated on structural Drawings.
 2. Maximum Moisture Content: 23 percent.
 3. Additional Restriction: Free of heart centers.
- 2.6 ENGINEERED WOOD PRODUCTS
- A. Composite Wood Products: Products shall be made using ultra-low-emitting formaldehyde resins as defined in California Air Resources Board's "Airborne Toxic Control Measure to Reduce Formaldehyde Emissions from Composite Wood Products" or shall be made with no added formaldehyde.
- B. Source Limitations: Obtain each type of engineered wood product from single source from a single manufacturer.
- C. Laminated-Veneer Lumber: Structural composite lumber made from wood veneers with grain primarily parallel to member lengths, evaluated and monitored according to ASTM D5456 and manufactured with an exterior-type adhesive complying with ASTM D2559.

1. Manufacturers: Subject to compliance with requirements, provide products by one of the following:
 - a. Boise Cascade Corporation.
 - b. Louisiana-Pacific Corporation.
 - c. Pacific Woodtech Corporation.
 - d. RedBuilt, LLC.
 - e. Roseburg Forest Products.
 - f. Weyerhaeuser Company.
 - g. Approved substitution.
 2. Laminated-Veneer Lumber Properties: As indicated on structural Drawings.
- D. Parallel-Strand Lumber: Structural composite lumber made from wood strand elements with grain primarily parallel to member lengths, evaluated and monitored according to ASTM D5456 and manufactured with an exterior-type adhesive complying with ASTM D2559.
1. Manufacturers: Subject to compliance with requirements, provide products by one of the following:
 - a. Louisiana-Pacific Corporation.
 - b. Pacific Woodtech Corporation.
 - c. RedBuilt, LLC.
 - d. Weyerhaeuser Company.
 - e. Approved substitution.
 2. Parallel-Strand Lumber Properties: As indicated on structural Drawings.
- E. Wood I-Joists: Prefabricated units, I-shaped in cross section, made with solid or structural composite lumber flanges and wood-based structural panel webs, let into and bonded to flanges. Comply with material requirements of and with structural capacities established and monitored according to ASTM D5055.
1. Manufacturers: Subject to compliance with requirements, provide products by one of the following:
 - a. Boise Cascade Corporation.
 - b. Louisiana-Pacific Corporation.
 - c. RedBuilt, LLC.
 - d. Roseburg Forest Products.
 - e. Weyerhaeuser Company.
 - f. Approved substitution.
 2. Web Material: Either oriented strand board or plywood, complying with DOC PS 2, Exposure 1, not less than those indicated.
 3. Wood I-Joist Properties: As indicated on structural Drawings.
 4. Comply with APA PRI-400. Factory mark I-joists with APA-EWS trademark indicating nominal joist depth, joist class, span ratings, mill identification, and compliance with APA-EWS standard.
- F. Rim Boards: Product designed to be used as a load-bearing member and to brace wood I-joists at bearing ends, complying with research or evaluation report for I-joists.
1. Manufacturer: Provide products by same manufacturer as I-joists.
 2. Material: : As indicated on structural Drawings.
 3. Thickness: As indicated on structural Drawings.
 4. Comply with APA PRR-401, rim board grade. Factory mark rim boards with APA-EWS trademark indicating thickness, grade, and compliance with APA-EWS standard.
- 2.7 SHEAR WALL PANELS
- A. Manufacturers: Subject to compliance with requirements, provide products by one of the following:
1. Shear Transfer Systems.
 2. Simpson Strong-Tie Co., Inc.
 3. Weyerhaeuser Company.

- B. Wood-Framed Shear Wall Panels: Prefabricated assembly consisting of wood perimeter framing, tie downs, and Exposure I, Structural I plywood or OSB sheathing.
- C. Allowable design loads, as published by manufacturer, shall meet or exceed those of basis-of-design products. Manufacturer's published values shall be determined from empirical data or by rational engineering analysis and demonstrated by comprehensive testing performed by a qualified independent testing agency.

2.8 MISCELLANEOUS LUMBER

- A. General: Provide miscellaneous lumber indicated and lumber for support or attachment of other construction, including the following:
 - 1. Blocking.
 - 2. Nailers.
 - 3. Rooftop equipment bases and support curbs.
 - 4. Furring.
- B. Dimension Lumber Items: Construction or No. 2 grade lumber of the following species:
 - 1. Hem-fir; WCLIB or WWPA.
 - 2. Western woods; WCLIB or WWPA.
- C. Concealed Boards: 15 percent maximum moisture content of any of the following species and grades:
 - 1. Hem-fir, Standard or No. 3 Common grade; WCLIB or WWPA.
 - 2. Western woods, Standard or No. 3 Common grade; WCLIB or WWPA.
- D. For blocking not used for attachment of other construction, Utility, Stud, or No. 3 grade lumber of any species may be used provided that it is cut and selected to eliminate defects that will interfere with its attachment and purpose.
- E. For blocking and nailers used for attachment of other construction, select and cut lumber to eliminate knots and other defects that will interfere with attachment of other Work.
- F. For furring strips for installing plywood or hardboard paneling, select boards with no knots capable of producing bent-over nails and damage to paneling.

2.9 PLYWOOD BACKING PANELS

- A. Equipment Backing Panels: Plywood, DOC PS 1, Exposure 1, C-D Plugged, fire-retardant treated, not less than 3/4 inch nominal thickness unless indicated otherwise.

2.10 FASTENERS

- A. Provide fasteners of size and type indicated, that comply with requirements specified in this Article for material and manufacture, and are acceptable to authorities having jurisdiction.
 - 1. Where rough carpentry is exposed to weather, in ground contact, pressure-preservative treated, or in area of high relative humidity, provide fasteners with hot-dip zinc coating complying with ASTM A153.
- B. Nails, Brads, and Staples: ASTM F1667.
- C. Power-Driven Fasteners: Fastener systems with an evaluation report acceptable to authorities having jurisdiction, based on ICC-ES AC70.
- D. Post-Installed Anchors: Fastener systems with an evaluation report acceptable to authorities having jurisdiction, as appropriate for substrate, as indicated on structural Drawings:

2.11 METAL FRAMING ANCHORS

- A. Manufacturers: Subject to compliance with requirements, provide products by one of the following:
 - 1. Cleveland Steel Specialty Co.
 - 2. KC Metals Products, Inc.
 - 3. Phoenix Metal Products, Inc.
 - 4. Simpson Strong-Tie Co., Inc.
 - 5. USP Structural Connectors.
 - 6. Approved substitution.
- B. Allowable design loads, as published by manufacturer, shall meet or exceed those of basis-of-design products. Manufacturer's published values shall be determined from empirical data or by rational engineering analysis and demonstrated by comprehensive testing performed by a qualified independent testing agency. Framing anchors shall be punched for fasteners adequate to withstand same loads as framing anchors.
- C. Galvanized-Steel Sheet: Hot-dip, zinc-coated steel sheet complying with ASTM A653, G60 coating designation.
 - 1. Use for interior locations unless otherwise indicated.
- D. Hot-Dip, Heavy-Galvanized Steel Sheet: ASTM A653; structural steel (SS), high-strength low-alloy steel Type A (HSLAS Type A), or high-strength low-alloy steel Type B (HSLAS Type B); G185 coating designation; and not less than 0.034 inch thick.
 - 1. Use for wood-preservative-treated lumber and where indicated.
- E. Stainless-Steel Sheet: ASTM A666, Type 304.
 - 1. Use for exterior locations and where indicated.
- F. Bridging: Rigid, V-section, nailless type, 0.050 inch thick, length to suit joist size and spacing.

2.12 MISCELLANEOUS MATERIALS

- A. Sill-Sealer Gaskets: Glass-fiber-resilient insulation, fabricated in strip form, for use as a sill sealer; 1 inch nominal thickness, compressible to 1/32 inch; selected from manufacturer's standard widths to suit width of sill members indicated.
- A. Flexible Flashing: Composite, self-adhesive, flashing product as specified in Section 076500 – Flexible Flashing.
- B. Adhesives for Gluing Furring to Concrete or Masonry: Formulation complying with ASTM D3498 that is approved for use indicated by adhesive manufacturer.
 - 1. Verify VOC content is 70 g/L or less.
 - 2. Verify products comply with testing and product requirements of California Department of Public Health's "Standard Method for the Testing and Evaluation of Volatile Organic Chemical Emissions from Indoor Sources Using Environmental Chambers."
- C. Water-Repellent Preservative: NWWDA-tested and -accepted formulation containing 3-iodo-2-propynyl butyl carbamate, combined with an insecticide containing chlorpyrifos as its active ingredient.

PART 3 - EXECUTION

3.1 INSTALLATION, GENERAL

- A. Framing Standard: Comply with AF&PA's WCD 1, "Details for Conventional Wood Frame Construction," unless otherwise indicated.

- B. Framing with Engineered Wood Products: Install engineered wood products to comply with manufacturer's written instructions.
- C. Set rough carpentry to required levels and lines, with members plumb, true to line, cut, and fitted. Fit rough carpentry accurately to other construction. Locate furring, nailers, blocking, and similar supports to comply with requirements for attaching other construction.
- D. Install plywood backing panels by fastening to studs; coordinate locations with utilities requiring backing panels. Install fire-retardant-treated plywood backing panels with classification marking of testing agency exposed to view.
- E. Install metal framing anchors to comply with manufacturer's written instructions. Install fasteners through each fastener hole.
- F. Install sill sealer gasket to form continuous seal between sill plates and foundation walls.
- G. Do not splice structural members between supports unless otherwise indicated.
- H. Provide blocking and framing as indicated and as required to support facing materials, fixtures, specialty items, and trim.
 - 1. Provide metal clips for fastening gypsum board at corners and intersections where framing or blocking does not provide a surface for fastening edges of panels. Space clips not more than 16 inches on center.
- I. Provide fire blocking in furred spaces, stud spaces, and other concealed cavities as indicated and as follows:
 - 1. Furred spaces of walls, at each floor level, at ceiling, and at not more than 96 inches on center with solid wood blocking or noncombustible materials accurately fitted to close furred spaces.
 - 2. Concealed spaces of wood-framed walls and partitions at each floor level, at ceiling line of top story, and at not more than 96 inches on center. Where fire blocking is not inherent in framing system used, provide closely fitted solid wood blocks of same width as framing members and 2 inch nominal thickness.
 - 3. Concealed spaces between floor sleepers with same material as sleepers to limit concealed spaces to not more than 100 sq. ft. and to solidly fill space below partitions.
 - 4. Concealed spaces behind combustible cornices and exterior trim at not more than 20 feet on center.
- J. Sort and select lumber so that natural characteristics do not interfere with installation or with fastening other materials to lumber. Do not use materials with defects that interfere with function of member or pieces that are too small to use with minimum number of joints or optimum joint arrangement.
- K. Apply copper naphthenate field treatment in compliance with AWPA M4, to cut surfaces of preservative-treated lumber.
 - 1. Application: Items not continuously protected from liquid water.
- L. Where wood-preservative-treated lumber is installed adjacent to metal decking, install continuous flexible flashing separator between wood and metal decking.
- M. Securely attach rough carpentry Work to substrate by anchoring and fastening as indicated, complying with the following:
 - 1. ICC-ES evaluation report for fastener.
- N. Use steel common nails unless otherwise indicated. Select fasteners of size that will not fully penetrate members where opposite side will be exposed to view or will receive finish materials. Make tight connections between members. Install fasteners without splitting wood. Drive nails snug but do not countersink nail heads unless otherwise indicated.

3.2 INSTALLATION OF WOOD BLOCKING AND NAILERS

- A. Install where indicated and where required for attaching other Work. Form to shapes indicated and cut as required for true line and level of attached Work. Coordinate locations with other Work involved.
- B. Attach items to substrates to support applied loading. Recess bolts and nuts flush with surfaces unless otherwise indicated.

3.3 INSTALLATION OF WOOD FURRING

- A. Install level and plumb with closure strips at edges and openings. Shim with wood as required for tolerance of finish Work.
- B. Furring to Receive Plywood or Paneling: Install 1 by 3 inch nominal-size furring at 24 inches on center
- C. Furring to Receive Gypsum Board: Install 1 by 2 inch nominal-size furring vertically at 16 inches on center

3.4 INSTALLATION OF WALL AND PARTITION FRAMING

- A. General: Provide single bottom plate and double top plates using members of 2 inch nominal thickness whose widths equal that of studs, except single top plate may be used for non-load-bearing partitions. Fasten plates to supporting construction unless otherwise indicated.
 - 1. For exterior walls, provide 2 by 6 inch nominal size wood studs spaced 16 inches on center unless otherwise indicated.
 - 2. For interior partitions and walls, provide 2 by 6 inch or 2 by 4 inch nominal size wood studs spaced 16 inches on center unless otherwise indicated.
 - 3. Provide continuous horizontal blocking at midheight of partitions more than 96 inches high, using members of 2 inch nominal thickness and of same width as wall or partitions.
- B. Construct corners and intersections with 3 or more studs, except that 2 studs may be used for interior non-load-bearing partitions.
- C. Frame openings with multiple studs and headers. Provide nailed header members of thickness equal to width of studs. Support headers on jamb studs.
 - 1. For non-load-bearing partitions, provide double-jamb studs and headers not less than 4 inch nominal depth for openings 48 inches and less in width, 6 inch nominal depth for openings 48 to 72 inches in width, 8 inch nominal depth for openings 72 to 120 inches in width, and not less than 10 inch nominal depth for openings 10 to 12 feet in width.
 - 2. For load-bearing walls, provide double-jamb studs for openings 60 inches and less in width, and triple-jamb studs for wider openings. Provide headers of depth indicated.

3.5 INSTALLATION OF FLOOR JOIST FRAMING

- A. General: Install floor joists with crown edge up and support ends of each member with not less than 1-1/2 inches of bearing on wood. Attach floor joists as follows:
 - 1. Where supported on wood members, by toe nailing or by using metal framing anchors.
 - 2. Where framed into wood supporting members, by using wood ledgers as indicated or, if not indicated, by using metal joist hangers.
- B. Fire Cuts: At joists built into masonry, bevel cut ends 3 inches and do not embed more than 4 inches.
- C. Frame openings with headers and trimmers supported by metal joist hangers; double headers and trimmers where span of header exceeds 48 inches.
- D. Do not notch in middle third of joists; limit notches to 1/6 depth of joist, 1/3 at ends. Do not bore holes larger than 1/3 depth of joist; do not locate closer than 2 inches from top or bottom.

- E. Provide solid blocking of 2 inch nominal thickness by depth of joist at ends of joists unless nailed to header or band.
- F. Lap members framing from opposite sides of beams, girders, or partitions not less than 4 inches or securely tie opposing members together. Provide solid blocking of 2 inch nominal thickness by depth of joist over supports.
- G. Provide solid blocking between joists under jamb studs for openings.
- H. Under non-load-bearing partitions, provide double joists separated by solid blocking equal to depth of studs above.
 - 1. Provide triple joists separated as above, under partitions receiving ceramic tile and similar heavy finishes or fixtures.
- I. Provide bridging of type indicated below, at intervals of 96 inches on center between joists.
 - 1. Diagonal wood bridging formed from bevel-cut, 1 by 3 inch nominal-size lumber, double-crossed and nailed at both ends to joists.
 - 2. Steel bridging installed to comply with bridging manufacturer's written instructions.

3.6 INSTALLATION OF CEILING JOIST AND RAFTER FRAMING

- A. Ceiling Joists: Install with crown edge up and complying with requirements specified above for floor joists. Face nail to ends of parallel rafters.
 - 1. Where ceiling joists are at right angles to rafters, provide additional short joists parallel to rafters from wall plate to first joist; nail to ends of rafters and to top plate, and nail to first joist or anchor with framing anchors or metal straps. Provide 1 by 8 inch nominal-size or 2 by 4 inch nominal-size stringers spaced 48 inches on center crosswise over main ceiling joists.
- B. Rafters: Notch to fit exterior wall plates and use metal framing anchors. Double rafters to form headers and trimmers at openings in roof framing, if any, and support with metal hangers. Where rafters abut at ridge, place directly opposite each other and nail to ridge member or use metal ridge hangers.
 - 1. At valleys, provide double-valley rafters of size indicated or, if not indicated, of same thickness as regular rafters and 2 inches deeper. Bevel ends of jack rafters for full bearing against valley rafters.
 - 2. At hips, provide hip rafter of size indicated or, if not indicated, of same thickness as regular rafters and 2 inches deeper. Bevel ends of jack rafters for full bearing against hip rafter.
- C. Provide collar beams (ties) as indicated or, if not indicated, provide 1 by 6 inch nominal-size boards between every third pair of rafters, but not more than 48 inches on center. Locate below ridge member, at third point of rafter span. Cut ends to fit roof slope and nail to rafters.
- D. Provide special framing as indicated for eaves, overhangs, dormers, and similar conditions if any.

3.7 INSTALLATION OF STAIR FRAMING

- A. Provide stair framing members of size, space, and configuration indicated or, if not indicated, to comply with requirements as indicated on structural Drawings.
- B. Provide stair framing with no more than 3/16 inch variation between adjacent treads and risers and no more than 3/8 inch variation between largest and smallest treads and risers within each flight.

3.8 PROTECTION

- A. Protect wood that has been treated with inorganic boron (SBX) from weather. If, despite protection, inorganic boron-treated wood becomes wet, apply EPA-registered borate treatment. Apply borate solution by spraying to comply with EPA-registered label.
- B. Protect rough carpentry from weather. If, despite protection, rough carpentry becomes wet enough that moisture content exceeds that specified, apply EPA-registered borate treatment. Apply borate solution by spraying to comply with EPA-registered label.

END OF SECTION 061000

SECTION 061600
SHEATHING

PART 1 - GENERAL

1.1 SUMMARY

- A. Section Includes:
1. Gypsum board sheathing.
 2. Wood structural panel sheathing.
 3. Subflooring.
 4. Underlayment.
 5. Sheathing joint-and-penetration treatment materials.

1.2 ACTION SUBMITTALS

- A. Product Data: For each type of process and factory-fabricated product. Indicate component materials and dimensions and include construction and application details.
1. Include data for fire-retardant treatment from chemical treatment manufacturer and certification by treating plant that treated plywood complies with requirements. Include physical properties of treated materials.
 2. For fire-retardant treatments, include physical properties of treated plywood both before and after exposure to elevated temperatures, based on testing by a qualified independent testing agency in accordance with ASTM D5516.
 3. For products receiving waterborne treatment, include statement that moisture content of treated materials was reduced to levels specified before shipment to Project site.
- B. Sustainable Design Submittals:
1. Chain-of-Custody Certificates: For certified wood products. Include statement of costs.
 2. Chain-of-Custody Qualification Data: For manufacturer and vendor.
 3. Laboratory Test Reports: For composite wood products, indicating compliance with requirements for low-emitting materials.
 4. Product Data: For installation adhesives, indicating VOC content.
 5. Laboratory Test Reports: For installation adhesives, indicating compliance with requirements for low-emitting materials.
 6. Product Data: For installation adhesives, indicating VOC content.
 7. Laboratory Test Reports: For installation adhesives, indicating compliance with requirements for low-emitting materials.

1.3 INFORMATIONAL SUBMITTALS

- A. Evaluation Reports: For the following, from ICC-ES:
1. Fire-retardant-treated plywood.

1.4 QUALITY ASSURANCE

- A. Certified Wood: Provide an invoice including vendor's chain-of-custody number, product cost, and entity being invoiced.
- B. Vendor Qualifications: A vendor that is certified for chain of custody by an FSC-accredited certification body.

1.5 DELIVERY, STORAGE, AND HANDLING

- A. Deliver materials in original, unopened packaging and store in an enclosed shelter providing protection from damage and exposure to the elements.
 - 1. Store within temperature limits required by manufacturer.
 - 2. Store air- and water-resistive sheathing board supported on risers on a flat platform.
 - 3. Comply with manufacturer's written instructions for safety and handling.
- B. Store accessory materials in a location with constant ambient temperatures of 40 to 80 deg F.
- C. Stack panels flat with spacers beneath and between each bundle to provide air circulation. Protect sheathing from weather by covering with waterproof sheeting, securely anchored. Provide for air circulation around stacks and under coverings.

1.6 WARRANTY

PART 2 - PRODUCTS

2.1 PERFORMANCE CRITERIA

- A. Fire-Resistance Ratings: As tested per ASTM E119; testing by a qualified testing agency. Identify products with appropriate markings of applicable testing agency.
 - 1. Fire-Resistance Ratings: Indicated by design designations from UL's "Fire Resistance Directory" or from listings of another qualified testing agency.

2.2 FIRE-RETARDANT-TREATED PLYWOOD

- A. Where fire-retardant-treated materials are indicated, use materials complying with requirements in this article that are acceptable to authorities having jurisdiction and with fire-test-response characteristics specified as determined by testing identical products per test method indicated by a qualified testing agency.
- B. Fire-Retardant-Treated Plywood by Pressure Process: Products with a flame-spread index of 25 or less when tested according to ASTM E84, and with no evidence of significant progressive combustion when test is extended an additional 20 minutes, and with flame front not extending more than 10.5 feet beyond centerline of burners at any time during test.
 - 1. Use treatment that does not promote corrosion of metal fasteners.
 - 2. Exterior Type: Treated materials shall comply with requirements specified above for fire-retardant-treated plywood by pressure process after being subjected to accelerated weathering according to ASTM D2898. Use for exterior locations and where indicated.
 - 3. Interior Type A: Treated materials shall have a moisture content of 28 percent or less when tested according to ASTM D3201 at 92 percent relative humidity. Use where exterior type is not indicated.
 - 4. Design Value Adjustment Factors: Treated lumber plywood shall be tested according to ASTM D5516 and design value adjustment factors shall be calculated according to ASTM D6305. Span ratings after treatment shall be not less than span ratings specified.
- C. Kiln-dry material after treatment to a maximum moisture content of 15 percent. Do not use material that is warped or does not comply with requirements for untreated material.
- D. Identify fire-retardant-treated plywood with appropriate classification marking of qualified testing agency.
- E. Application: Treat plywood indicated on Drawings, and the following:

2.3 WALL SHEATHING

- A. Glass-Mat Fiber-Reinforced Gypsum Sheathing: ASTM C1177, with fiberglass mat laminated to both sides and with manufacturer's standard edges.
 - 1. Products: Subject to compliance with requirements, provide one of the following:
 - a. CertainTeed Corporation: GlasRoc Type X.
 - b. Georgia-Pacific Gypsum LLC: DensGlass Fireguard Sheathing.
 - c. National Gypsum Company: Gold Bond eXP Fire-Shield Interior Extreme Gypsum Panel.
 - d. USG Corporation: Securock Glass-Mat Sheathing Firecode X.
 - e. Approved substitution.
 - 2. Type and Thickness: Regular, Type X, 5/8 inch thick.
 - 3. Size: 48 inches by longest practical length for vertical installation.
 - 4. Maximum framing spacing is 16 inches on center.
- B. Tile Backer Units: Cementitious tile backer units as specified in Section 092900 – Gypsum Board.
- C. Plywood Wall Sheathing: As indicated on structural Drawings.

2.4 ROOF SHEATHING

- A. Oriented-Strand-Board Sheathing: As indicated on structural Drawings.
 - 1. Field verify thickness to match existing at locations required to replace existing damaged roof sheathing.
 - a. Submit discrepancies to Architect for review prior to ordering or proceeding with Work.
- B. (Alternate): Plywood Roof Sheathing: As indicated on structural Drawings.
 - 1. Field verify thickness to match existing at locations required to replace existing damaged roof sheathing.
 - a. Submit discrepancies to Architect for review prior to ordering or proceeding with Work.

2.5 PARAPET SHEATHING

- A. Oriented-Strand-Board Sheathing: As indicated on structural Drawings.

2.6 SUBFLOORING AND UNDERLAYMENT

- A. Oriented-Strand-Board Combination Subfloor-Underlayment: As indicated on structural Drawings.

2.7 FASTENERS

- A. General: Provide fasteners of size and type indicated that comply with requirements specified in this article for material and manufacture.
 - 1. Provide screws with hot-dip zinc coating complying with ASTM A153.
- B. Power-Driven Fasteners: Fastener systems with an evaluation report acceptable to authorities having jurisdiction, based on ICC-ES AC70.
- C. Screws for Fastening Sheathing to Framing: For gypsum and wood panel sheathing, comply with the following:
 - 1. Wood Framing Metal Framing: ASTM C1002.

2.8 SHEATHING JOINT-AND-PENETRATION TREATMENT MATERIALS

- A. Sealant for Glass-Mat Gypsum Sheathing: Silicone emulsion sealant complying with ASTM C834, compatible with sheathing tape and sheathing and recommended by tape and sheathing manufacturers for use with glass-fiber sheathing tape and for covering exposed fasteners.

1. Sheathing Tape: Self-adhering glass-fiber tape, minimum 2 inches wide, 10 by 10 or 10 by 20 threads per inch, of type recommended by sheathing and tape manufacturers for use with silicone emulsion sealant in sealing joints in glass-mat gypsum sheathing and with a history of successful in-service use.
- B. Joint Compound for Exterior Applications:
1. Glass-Mat Gypsum Sheathing Board: As recommended by manufacturer.

PART 3 - EXECUTION

3.1 INSTALLATION, GENERAL

- A. Do not use materials with defects that impair quality of sheathing or pieces that are too small to use with minimum number of joints or optimum joint arrangement. Arrange joints so that pieces do not span between fewer than 3 support members.
- B. Cut panels at penetrations, edges, and other obstructions of Work; fit tightly against abutting construction unless otherwise indicated.
- C. Coordinate sheathing installation with flashing and joint-sealant installation so these materials are installed in sequence and manner that prevent exterior moisture from passing through completed assembly.
- D. Do not bridge building expansion joints; cut and space edges of panels to match spacing of structural support elements.
- E. Coordinate sheathing installation with installation of materials installed over sheathing so sheathing is not exposed to precipitation or left exposed at end of workday when rain is forecast.

3.2 INSTALLATION OF GYPSUM SHEATHING

- A. Comply with GA-253 and with manufacturer's written instructions.
 1. Fasten gypsum sheathing to wood framing with screws.
 2. Install boards with a 3/8 inch gap where non-load-bearing construction abuts structural elements.
 3. Install boards with a 1/4 inch gap where they abut masonry or similar materials that might retain moisture, to prevent wicking.
- B. Apply fasteners so heads bear tightly against face of sheathing, but do not cut into facing.
- C. Horizontal Installation: Install sheathing with V-grooved edge down and tongue edge up. Interlock tongue with groove to bring long edges in contact with edges of adjacent boards without forcing. Abut ends of boards over centers of studs, and stagger end joints of adjacent boards not less than 1 stud spacing. Attach boards at perimeter and within field of board to each steel stud.
 1. Space fasteners approximately 8 inches on center and set back a minimum of 3/8 inch from edges and ends of boards.
- D. Seal sheathing joints according to sheathing manufacturer's written instructions.
 1. Apply glass-fiber sheathing tape to glass-mat gypsum sheathing joints and apply and trowel sealant to embed entire face of tape in sealant. Apply sealant to exposed fasteners with a trowel so fasteners are completely covered. Seal other penetrations and openings.

3.3 INSTALLATION OF WOOD STRUCTURAL PANEL

- A. General: Comply with applicable recommendations in APA Form No. E30, "Engineered Wood Construction Guide," for types of structural-use panels and applications indicated.

- B. Fastening Methods: Fasten panels as indicated below:
 - 1. Combination Subfloor-Underlayment:
 - a. Glue and Screw to wood framing.
 - b. Space panels 1/8 inch apart at edges and ends.
 - 2. Subflooring:
 - a. Glue and Screw to wood framing.
 - b. Space panels 1/8 inch apart at edges and ends.
 - 3. Underlayment:
 - a. Screw to subflooring.
 - b. Space panels 1/32 inch apart at edges and ends.
 - c. Fill and sand edge joints of underlayment receiving resilient flooring immediately before installing flooring.
 - 4. Wall and Roof Sheathing:
 - a. Screw to wood framing. Apply a continuous bead of glue to framing members at edges of wall sheathing panels.
 - b. Space panels 1/8 inch apart at edges and ends.
- 3.4 INSTALLATION OF CEMENTITIOUS BACKER UNITS
- A. Comply with manufacturer's written instructions for type of application indicated.
 - B. Refer to Section 092900 for installation of cementitious tile backer units.
- 3.5 PROTECTION
- A. Gypsum Sheathing: Protect sheathing by covering exposed exterior surface of sheathing with weather-resistant sheathing paper securely fastened to framing. Apply covering immediately after sheathing is installed.

END OF SECTION 061600

SECTION 061753
SHOP-FABRICATED WOOD TRUSSES

PART 1 - GENERAL

1.1 SUMMARY

- A. Section Includes:
1. Wood roof trusses.
 2. Wood girder trusses.

1.2 ACTION SUBMITTALS

- A. Sustainable Design Submittals:
1. Environmental Product Declaration (EPD): For each product.
 2. Chain-of-Custody Certificates: For certified wood products. Include statement of costs.
 3. Chain-of-Custody Qualification Data: For manufacturer and vendor.
- B. Shop Drawings: Show fabrication and installation details for trusses.
1. Show location, pitch, span, camber, configuration, and spacing for each type of truss required.
 2. Indicate sizes, stress grades, and species of lumber.
 3. Indicate locations of permanent bracing required to prevent buckling of individual truss members due to design loads.
 4. Indicate locations, sizes, and materials for permanent bracing required to prevent buckling of individual truss members due to design loads.
 5. Indicate type, size, material, finish, design values, orientation, and location of metal connector plates.
 6. Show splice details and bearing details.
 7. Submit Shop Drawings that have been engineered and certified by professional engineer licensed in the State in which Project is located. Include seal and signature of professional engineer on Shop Drawings.
- C. Delegated-Design Submittal: For metal-plate-connected wood trusses indicated to comply with performance requirements and design criteria, including analysis data signed and sealed by qualified professional engineer responsible for their preparation.

1.3 INFORMATIONAL SUBMITTALS

- A. Qualification Data: For metal connector-plate manufacturer and fabricator.
- B. Material Certificates: For dimension lumber specified to comply with minimum specific gravity. Indicate species and grade selected for each use and specific gravity.
- C. Product Certificates: For metal-plate-connected wood trusses, signed by officer of truss-fabricating firm.
- D. Evaluation Reports: For the following, from ICC-ES:
1. Metal-plate connectors.
 2. Metal truss accessories.

1.4 QUALITY ASSURANCE

- A. Metal Connector-Plate Manufacturer Qualifications: A manufacturer that is a member of TPI and that complies with quality-control procedures in TPI 1 for manufacture of connector plates.
 - 1. Manufacturer's responsibilities include providing professional engineering services needed to assume engineering responsibility.
 - 2. Engineering Responsibility: Preparation of Shop Drawings and comprehensive engineering analysis by a qualified professional engineer.
- B. Fabricator Qualifications: Shop that participates in a recognized quality-assurance program, complies with quality-control procedures in TPI 1, and involves third-party inspection by an independent testing and inspecting agency acceptable to Architect and authorities having jurisdiction and is certified for chain of custody by an FSC-accredited certification body.
- C. Certified Wood: Provide an invoice including vendor's chain-of-custody number, product cost, and entity being invoiced.
- D. Vendor Qualifications: A vendor that is certified for chain of custody by an FSC-accredited certification body.

1.5 DELIVERY, STORAGE, AND HANDLING

- A. Handle and store trusses to comply with recommendations in SBCA BCSI, "Building Component Safety Information: Guide to Good Practice for Handling, Installing, Restraining, & Bracing Metal Plate Connected Wood Trusses."
 - 1. Store trusses flat, off of ground, and adequately supported to prevent lateral bending.
 - 2. Protect trusses from weather by covering with waterproof sheeting, securely anchored.
 - 3. Provide for air circulation around stacks and under coverings.
- B. Inspect trusses showing discoloration, corrosion, or other evidence of deterioration. Discard and replace trusses that are damaged or defective.

PART 2 - PRODUCTS

2.1 PERFORMANCE CRITERIA

- A. Delegated Design: Engage a qualified professional engineer, as defined in Section 014000 – Quality Requirements, to design metal-plate-connected wood trusses.
- B. Structural Performance: Metal-plate-connected wood trusses shall be capable of withstanding design loads within limits and under conditions indicated. Comply with requirements in TPI 1 unless more stringent requirements are specified below.
 - 1. Design Loads: As indicated on structural Drawings.
 - 2. Maximum Deflection under Design Loads: As indicated on structural Drawings.
- C. Comply with applicable requirements and recommendations of TPI 1, TPI DSB, and SBCA BCSI.
- D. Wood Structural Design Standard: Comply with applicable requirements in AF&PA's "National Design Specifications for Wood Construction" and its "Supplement."
- E. Certified Wood: Wood products shall be certified as "FSC Pure" according to FSC STD-01-001 and FSC STD-40-004.

2.2 DIMENSION LUMBER

- A. Lumber: DOC PS 20 and applicable rules of any rules-writing agency certified by the American Lumber Standard Committee (ALSC) Board of Review. Provide lumber graded by an agency certified by the ALSC Board of Review to inspect and grade lumber under the rules indicated.
 - 1. Factory mark each piece of lumber with grade stamp of grading agency.
 - 2. For exposed lumber indicated to receive a stained or natural finish, omit grade stamp and provide certificates of grade compliance issued by grading agency.
 - 3. Provide dressed lumber, S4S.
 - 4. Provide dry lumber with 15 percent maximum moisture content at time of dressing.
- B. Minimum Chord Size for Roof Trusses: 2 by 6 inches nominal for both top and bottom chords, unless indicated otherwise.
- C. Minimum Specific Gravity for Top Chords: 0.50.
- D. Permanent Bracing: Provide wood bracing that complies with requirements for miscellaneous lumber as indicated on structural Drawings.

2.3 METAL CONNECTOR PLATES

- A. Manufacturers: Subject to compliance with requirements, provide products by one of the following:
 - 1. Alpine Engineered Products, Inc.; a division of ITW Building Components Group, Inc.
 - 2. Cherokee Metal Products, Inc.; Masengill Machinery Company.
 - 3. CompuTrus, Inc.
 - 4. Eagle Metal Products.
 - 5. Jager Building Systems, Inc.
 - 6. MiTek Industries, Inc.
 - 7. Robbins Engineering, Inc.
 - 8. Truswal Systems Corporation.
- B. General: Fabricate connector plates to comply with TPI 1.
- C. Hot-Dip Galvanized-Steel Sheet: ASTM A 653; Structural Steel (SS), high-strength low-alloy steel Type A (HSLAS Type A), or high-strength low-alloy steel Type B (HSLAS Type B); G60 coating designation; and not less than 0.036 inch thick.
 - 1. Use for interior locations unless otherwise indicated.

2.4 FASTENERS

- A. General: Provide fasteners of size and type indicated that comply with requirements specified in this article for material and manufacture.
 - 1. Provide fasteners for use with metal framing anchors that comply with written recommendations of metal framing manufacturer.
- B. Nails, Brads, and Staples: ASTM F 1667.

2.5 METAL FRAMING ANCHORS AND ACCESSORIES

- A. Manufacturers: Subject to compliance with requirements, provide products by one of the following:
 - 1. Cleveland Steel Specialty Co.
 - 2. KC Metals Products, Inc.
 - 3. Phoenix Metal Products, Inc.
 - 4. Simpson Strong-Tie Co., Inc.
 - 5. USP Structural Connectors.

- B. Allowable design loads, as published by manufacturer, shall comply with or exceed those of basis-of-design products. Manufacturer's published values shall be determined from empirical data or by rational engineering analysis and demonstrated by comprehensive testing performed by a qualified independent testing agency. Framing anchors shall be punched for fasteners adequate to withstand same loads as framing anchors.
- C. Galvanized-Steel Sheet: Hot-dip, zinc-coated steel sheet complying with ASTM A 653, G60 coating designation.
 - 1. Use for interior locations unless otherwise indicated.

2.6 MISCELLANEOUS MATERIALS

- A. Galvanizing Repair Coating: Zinc-rich, cold galvanizing compound as specified in Section 055000 – Metal Fabrications.

2.7 FABRICATION

- A. Cut truss members to accurate lengths, angles, and sizes to produce close-fitting joints.
- B. Fabricate metal connector plates to sizes, configurations, thicknesses, and anchorage details required to withstand design loads for types of joint designs indicated.
- C. Assemble truss members in design configuration indicated; use jigs or other means to ensure uniformity and accuracy of assembly, with joints closely fitted to comply with tolerances in TPI 1. Position members to produce design camber indicated.
 - 1. Fabricate wood trusses within manufacturing tolerances in TPI 1.
- D. Connect truss members by metal connector plates located and securely embedded simultaneously in both sides of wood members by air or hydraulic press.

2.8 SOURCE QUALITY CONTROL

- A. Special Inspections: Owner will engage a qualified special inspector to perform special inspections.
 - 1. Provide special inspector with access to fabricator's documentation of detailed fabrication and quality-control procedures that provide a basis for inspection control of the workmanship and the fabricator's ability to conform to approved construction documents and referenced standards.
 - 2. Provide special inspector with access to places where wood trusses are being fabricated to perform inspections.
- B. Correct deficiencies in Work that special inspections indicate do not comply with Contract Documents.

PART 3 - EXECUTION

3.1 INSTALLATION

- A. Install wood trusses only after supporting construction is in place and is braced and secured.
- B. If trusses are delivered to Project site in more than one piece, assemble trusses before installing.
- C. Hoist trusses in place by lifting equipment suited to sizes and types of trusses required, exercising care not to damage truss members or joints by out-of-plane bending or other causes.
- D. Install and brace trusses according to TPI recommendations and as indicated.
- E. Install trusses plumb, square, and true to line and securely fasten to supporting construction.

- F. Space trusses as indicated on structural Drawings. Adjust and align trusses in location before permanently fastening.
 - G. Anchor trusses securely at bearing points; use metal truss tie-downs or floor truss hangers as applicable. Install fasteners through each fastener hole in metal framing anchors according to manufacturer's fastening schedules and written instructions.
 - H. Securely connect each truss ply required for forming built-up girder trusses.
 - 1. Anchor trusses to girder trusses as indicated.
 - I. Install and fasten permanent bracing during truss erection and before construction loads are applied. Anchor ends of permanent bracing where terminating at walls or beams.
 - 1. Install bracing as indicated on structural Drawings.
 - 2. Install and fasten strongback bracing vertically against vertical web of parallel-chord floor trusses at centers indicated.
 - J. Install wood trusses within installation tolerances in TPI 1.
 - K. Do not alter trusses in field. Do not cut, drill, notch, or remove truss members.
 - L. Replace wood trusses that are damaged or do not comply with requirements.
 - 1. Damaged trusses may be repaired according to truss repair details signed and sealed by qualified professional engineer responsible for truss design, when approved by Architect.
- 3.2 REPAIR
- A. Repair damaged galvanized coatings on exposed surfaces according to ASTM A 780 and manufacturer's written instructions.
- 3.3 PROTECTION
- A. Protect wood that has been treated with inorganic boron (SBX) from weather. If, despite protection, inorganic boron-treated wood becomes wet, apply EPA-registered borate treatment. Apply borate solution by spraying to comply with EPA-registered label.
 - B. Protect wood trusses from weather. If, despite protection, wood trusses become wet, apply EPA-registered borate treatment. Apply borate solution by spraying to comply with EPA-registered label.
- 3.4 FIELD QUALITY CONTROL
- A. Special Inspections: Owner will engage a qualified special inspector to perform special inspections to verify that temporary installation restraint/bracing and permanent individual truss member restraint/bracing are installed in accordance with approved truss submittal package.

END OF SECTION 061753

SECTION 061800
GLUED-LAMINATED CONSTRUCTION

PART 1 - GENERAL

1.1 SUMMARY

- A. Section includes:
1. Framing using structural glued-laminated timber.

1.2 DEFINITIONS

- A. Structural Glued-Laminated (Glulam) Timber: An engineered, stress-rated timber product assembled from selected and prepared wood laminations bonded together with adhesives and with grain of laminations approximately parallel longitudinally.

1.3 ACTION SUBMITTALS

- A. Product Data: For each type of product.
1. Include data on lumber, adhesives, fabrication, and protection.
 2. For connectors. Include installation instructions.
- B. Sustainable Design Submittals:
1. Environmental Product Declaration (EPD): For each product.
 2. Chain-of-Custody Certificates: For certified wood products. Include statement of costs.
 3. Chain-of-Custody Qualification Data: For manufacturer and vendor.
 4. Laboratory Test Reports: For laminating adhesives, indicating compliance with requirements for low-emitting materials.
- C. Shop Drawings:
1. Show layout of structural glued-laminated timber system and full dimensions of each member.
 2. Indicate species and laminating combination.
 3. Include large-scale details of connections.
 4. Include seismic design calculations.

1.4 INFORMATIONAL SUBMITTALS

- A. Certificates of Conformance: Issued by a qualified testing and inspecting agency indicating that structural glued-laminated timber complies with requirements in AITC A190.1.
- B. Research/Evaluation Reports: For structural glued-laminated timber and timber connectors, from ICC-ES.

1.5 QUALITY ASSURANCE

- A. Manufacturer Qualifications: An AITC- or APA-EWS-licensed firm, certified for chain of custody by an FSC-accredited certification body.
- B. Certified Wood: Provide an invoice including vendor's chain-of-custody number, product cost, and entity being invoiced.
- C. Vendor Qualifications: A vendor that is certified for chain of custody by an FSC-accredited certification body.

1.6 DELIVERY, STORAGE, AND HANDLING

- A. General: Comply with provisions in AITC 111.
- B. Individually wrap members using plastic-coated paper covering with water-resistant seams.

PART 2 - PRODUCTS

2.1 PERFORMANCE CRITERIA

- A. Structural Performance: Structural glued-laminated timber and connectors shall withstand effects of structural loads shown on Drawings without exceeding allowable design working stresses listed in AITC 117 or determined according to ASTM D3737 and acceptable to AHJ.
- B. Seismic Performance: Structural glued-laminated timber and connectors shall withstand effects of earthquake motions determined according to ASCE 7.

2.2 STRUCTURAL GLUED-LAMINATED TIMBER

- A. General: Provide structural glued-laminated timber that complies with AITC A190.1 and AITC 117 or research/evaluation reports acceptable to authorities having jurisdiction.
 - 1. Factory mark each piece of structural glued-laminated timber with AITC Quality Mark or APA-EWS trademark. Place mark on surfaces that are not exposed in completed Work.
 - 2. Provide structural glued-laminated timber made from single species.
 - 3. Provide structural glued-laminated timber made from solid lumber laminations; do not use laminated veneer lumber.
 - 4. Provide structural glued-laminated timber made with wet-use adhesive complying with AITC A190.1.
 - 5. Verify adhesives comply with testing and product requirements of California Department of Public Health's "Standard Method for the Testing and Evaluation of Volatile Organic Chemical Emissions from Indoor Sources Using Environmental Chambers."
- B. Certified Wood: Wood products shall be certified as "FSC Pure" according to FSC STD-01-001 and FSC STD-40-004.
- C. Species and Grades for Structural Glued-Laminated Timber: Douglas fir-larch in grades needed to comply with "Performance Criteria" Article and properties indicated on structural Drawings.
- D. Appearance Grade: Architectural, complying with AITC 110.
 - 1. For Architectural appearance grades, fill voids as required by AITC 110.

2.3 TIMBER CONNECTORS

- A. Manufacturers: Subject to compliance with requirements, provide products by one of the following:
 - 1. Cleveland Steel Specialty Co.
 - 2. Simpson Strong-Tie Co., Inc.
 - 3. USP Structural Connectors.
 - 4. Approved substitutions.
- B. Fabricate beam seats, shoes, hangers, connectors strap ties, tie rods, and other structural steel components as indicated on structural Drawings.
- C. Fabricate connectors and anchors as follows or as indicated on structural Drawings:
 - 1. Bolts: ASTM A307, Grade A; 3/4 inch diameter.
 - 2. Nuts: ASTM A563.
 - 3. Flat Washers: Where indicated.

- D. Finish steel assemblies and fasteners with rust-inhibitive primer, 2-mil dry film thickness.

2.4 MISCELLANEOUS MATERIALS

- A. End Sealer: Manufacturer's standard, transparent, colorless wood sealer that is effective in retarding the transmission of moisture at cross-grain cuts and is compatible with indicated finish.
- B. Penetrating Sealer: Manufacturer's standard, transparent, penetrating wood sealer that is compatible with indicated finish.

2.5 FABRICATION

- A. Shop fabricate for connections to greatest extent possible, including cutting to length and drilling bolt holes.
 - 1. Dress exposed surfaces as needed to remove planing and surfacing marks.
- B. End-Cut Sealing: Immediately after end cutting each member to final length, apply a saturation coat of end sealer to ends and other cross-cut surfaces, keeping surfaces flood coated for not less than 10 minutes.
- C. Seal Coat: After fabricating, sanding, and end-coat sealing, apply a heavy saturation coat of penetrating sealer on surfaces of each unit.

PART 3 - EXECUTION

3.1 EXAMINATION

- A. Examine substrates in areas to receive structural glued-laminated timber, with Installer present, for compliance with requirements, installation tolerances, and other conditions affecting performance of Work.
- B. Proceed with installation only after unsatisfactory conditions have been corrected.

3.2 INSTALLATION

- A. Erect structural glued-laminated timber true and plumb and with uniform, close-fitting joints. Provide temporary bracing to maintain lines and levels until permanent supporting members are in place.
 - 1. Handle and temporarily support glued-laminated timber to prevent surface damage, compression, and other effects that might interfere with indicated finish.
- B. Cutting: Avoid extra cutting after fabrication. Where field fitting is unavoidable, comply with requirements for shop fabrication.
- C. Fit structural glued-laminated timber by cutting and restoring exposed surfaces to match specified surfacing.
 - 1. Pre-drill for fasteners using timber connectors as templates.
 - 2. Finish exposed surfaces to remove planing or surfacing marks and to provide a finish equivalent to that produced by machine sanding with No. 120 grit sandpaper.
 - 3. Coat cross cuts with end sealer.
- D. Install timber connectors as indicated.
 - 1. Install bolts with same orientation within each connection and in similar connections, unless indicated otherwise.

3.3 REPAIR

- A. Repair damaged surfaces and finishes after completing erection. Replace damaged structural glued-laminated timber if repairs are not approved by Architect.

3.4 PROTECTION

- A. Do not remove wrappings on individually wrapped members until they no longer serve a useful purpose, including protection from weather, sunlight, soiling, and damage from Work of other trades.
 - 1. Coordinate wrapping removal with finishing Work. Retain wrapping where it can serve as a painting shield.
 - 2. Slit underside of wrapping to prevent accumulation of moisture inside wrapping.

END OF SECTION 061800

SECTION 062023
INTERIOR FINISH CARPENTRY

PART 1 - GENERAL

1.1 SUMMARY

- A. Section Includes:
 - 1. Interior standing and running trim.
 - 2. Shelving and clothes rods.
 - 3. Shelf standards and brackets.

1.2 ACTION SUBMITTALS

- A. Product Data: For each type of process and factory-fabricated product. Indicate component materials, dimensions, profiles, textures, and colors and include construction and application details.
- B. Sustainable Design Submittals:
 - 1. Environmental Product Declaration (EPD): For each product.
 - 2. Chain-of-Custody Certificates: For certified wood products. Include statement of costs.
 - 3. Chain-of-Custody Qualification Data: For manufacturer and vendor.
 - 4. Laboratory Test Reports: For composite wood products, indicating compliance with requirements for low-emitting materials.
 - 5. Product Data: For installation adhesives, indicating VOC content.
 - 6. Laboratory Test Reports: For installation adhesives, indicating compliance with requirements for low-emitting materials.
- C. Samples for Verification:
 - 1. For each species and cut of lumber and panel products with non-factory-applied finish, with 1/2 of exposed surface finished; 12 inch long sections for lumber and 80 sq. in. for panels.
 - 2. For each finish system and color of lumber and panel products with factory-applied finish, 12 inch long sections for lumber and 80 sq. in. for panels.
 - 3. Reclaimed Wood: 12 inch long sections of lumber indicating wood species, quality, and variation of condition of available stock.

1.3 INFORMATIONAL SUBMITTALS

- A. Qualification Data: For Installer and fabricator.
- B. Product Certificates: For each type of product.
- C. Quality Standard Compliance Certificates: AWI Quality Certification Program or WI Certified Compliance Program.
- D. Reclaimed Wood Certificate: For each species of reclaimed wood certifying that adequate quantity is available.

1.4 QUALITY ASSURANCE

- A. Certified Wood: Provide an invoice including vendor's chain-of-custody number, product cost, and entity being invoiced.
- B. Vendor Qualifications: A vendor that is certified for chain of custody by an FSC-accredited certification body.

- C. Fabricator Qualifications: Shop that employs skilled workers who custom-fabricate products similar to those required for this Project and whose products have a record of successful in-service performance.
 - 1. Shop Certification: AWI's Quality Certification Program (QCP) accredited participant.
 - D. Manufacturer Qualifications: A qualified manufacturer that is certified for chain of custody by an FSC-accredited certification body.
 - E. Mockups: Build mockups to verify selections made under Sample submittals, to demonstrate aesthetic effects, and to set quality standards for materials and execution.
 - 1. Build mockups of typical paneling as shown on Drawings.
 - 2. Subject to compliance with requirements, approved mockups may become part of completed Work if undisturbed at time of Substantial Completion.
- 1.5 DELIVERY, STORAGE, AND HANDLING
- A. Stack lumber, plywood, and other panels flat with spacers between each bundle to provide air circulation.
 - 1. Protect materials from weather by covering with waterproof sheeting, securely anchored.
 - 2. Provide for air circulation around stacks and under coverings.
 - B. Deliver interior finish carpentry materials only when environmental conditions comply with requirements specified for installation areas. If interior finish carpentry materials must be stored in other than installation areas, store only where environmental conditions comply with requirements specified for installation areas.
- 1.6 FIELD CONDITIONS
- A. Environmental Limitations: Do not deliver or install interior finish carpentry materials until building is enclosed and weatherproof, wet-Work in space is completed and nominally dry, and HVAC system is operating and maintaining temperature and relative humidity at occupancy levels during remainder of construction period.
 - B. Do not install finish carpentry materials that are wet, moisture damaged, or mold damaged.
 - 1. Indications that materials are wet or moisture damaged include, but are not limited to, discoloration, sagging, or irregular shape.
 - 2. Indications that materials are mold damaged include, but are not limited to, fuzzy or splotchy surface contamination and discoloration.

PART 2 - PRODUCTS

2.1 FABRICATORS

- A. Fabricators: Subject to compliance with requirements, provide products by one of the following:
 - 1. Advanced Custom Cabinets.
 - 2. Central Cabinet Systems, a division of Frontier Door & Cabinet.
 - 3. Custom Interiors.
 - 4. Genothen.
 - 5. ISEC.
 - 6. Northwest Millwork.
 - 7. Old Mill Cabinets and Millwork.
 - 8. Pacific Cabinets, Inc.
 - 9. Skagit Architectural Millwork.
 - 10. Approved substitutions.

- B. Source Limitations: Firm engaged to assume responsibility for production of interior finish carpentry shall be responsible for the following:
 - 1. Section 064023 – Interior Architectural Woodwork.
 - 2. Section 064100 – Architectural Wood Casework.

2.2 MATERIALS, GENERAL

- A. Certified Wood: The following wood products shall be certified as "FSC Pure" according to FSC STD-01-001 and FSC STD-40-004.
 - 1. Interior standing and running trim.
 - 2. Shelving.
- B. Composite Wood Products: Provide products made using ultra-low-emitting formaldehyde resins as defined in California Air Resources Board's "Airborne Toxic Control Measure to Reduce Formaldehyde Emissions from Composite Wood Products" or shall be made with no added formaldehyde.
 - 1. Medium-Density Fiberboard (MDF): ANSI A208.2, Grade 130.
 - a. Products: Subject to compliance with requirements, provide one of the following:
 - 1) ampine; Div. of Timber Products Company: Apex MDF.
 - 2) ARAUCO North America: Trupan Standard MDF.
 - 3) Del-Tin Fiber, LLC: Solidium Ultra MDF.
 - 4) Georgia-Pacific Wood Products LLC: UltraStock Premium MDF.
 - 5) Roseburg Forest Products Co.: Medite II.
 - 6) Timber Products Company: Masisa Ultralight MDF.
 - 7) West Fraser Timber Co., Ltd.: WestPine EcoGold MDF.
 - 8) Weyerhaeuser Company: Super-Refined MDF2.
- C. Lumber: DOC PS 20 and applicable rules of grading agencies indicated. If no grading agency is indicated, comply with applicable rules of any rules-writing agency certified by the American Lumber Standard Committee's (ALSC) Board of Review. Grade lumber by an agency certified by ALSC's Board of Review to inspect and grade lumber under the rules indicated.
 - 1. Factory mark each piece of lumber with grade stamp of grading agency.
 - 2. For exposed lumber, mark grade stamp on end or back of each piece or omit grade stamp and provide certificates of grade compliance issued by grading agency.
- D. Reclaimed Wood: Lumber fabricated from timber recovered from riverbeds or otherwise abandoned is permitted provided the following conditions are met:
 - 1. Wood is clean, non-impregnated, free of contamination, and not previously stained.
 - 2. Existing finishes have been removed.
 - 3. Wood is solid stock material free of marks, dents, and other defects.
 - 4. Wood source has been identified and lumber has been regraded by an agency certified by ALSC's Board of Review to inspect and grade lumber under rules indicated.
 - 5. Lumber fabricated from old growth timber is not permitted.
- E. Softwood Plywood: DOC PS 1, medium-density overlay (MDO).
- F. Hardboard: ANSI A135.4.
- G. Medium-Density Fiberboard (MDF): ANSI A208.2, Grade 130.
 - 1. Products: Subject to compliance with requirements, provide one of the following:
 - a. ampine; Div. of Timber Products Company: Apex MDF.
 - b. ARAUCO North America: Trupan Standard MDF.
 - c. Georgia-Pacific Wood Products LLC: UltraStock Premium MDF.
 - d. Roseburg Forest Products Co.: Medite II.
 - e. Timber Products Company: Masisa Ultralight MDF.
 - f. West Fraser Timber Co., Ltd.: WestPine EcoGold MDF.
 - g. Weyerhaeuser Company: Super-Refined MDF2.

- H. Thermoset Decorative Panels: MDF finished with thermally fused, melamine-impregnated decorative paper and complying with requirements of NEMA LD 3, Grade VGL, for Test Methods 3.3, 3.4, 3.6, 3.8, and 3.10.
 - 1. Color: As selected by Architect from manufacturer's full range.

2.3 INTERIOR TRIM

- A. Maximum Moisture Content of Finish Woods:
 - 1. Interior Use: Kiln dried or air dried to 5 percent. 10 percent maximum delivered to site.
- B. Softwood Lumber Trim for Transparent Finish (Stain or Clear Finish):
 - 1. Species and Grade:
 - a. Douglas fir-larch; WCLIB or WWPA.
 - b. Idaho white pine; WWPA.
 - c. Western red cedar; WCLIB or WWPA, Clear Heart.
 - 2. Cut: Plain sawn.
 - 3. Finger Jointing: Not allowed.
 - 4. Face Surface: Surfaced (smooth).
- C. Hardwood Lumber Trim for Transparent Finish (Stain or Clear Finish):
 - 1. Species and Grade: As selected by Architect; NHLA.
 - 2. Finger Jointing: Not allowed.
 - 3. Gluing for Width: Use for lumber base wider than 6 inches.
 - 4. Veneered Material: Use for lumber trim, other than base, wider than 6 inches.
 - 5. Face Surface: Surfaced (smooth).
 - 6. Matching: Selected for compatible grain and color.
- D. Lumber Trim for Opaque Finish (Painted Finish):
 - 1. Material: Primed MDF.
 - 2. Maximum Moisture Content: 15 percent with at least 85 percent of shipment at 12 percent or less.
 - 3. Finger Jointing: Allowed.
 - 4. Face Surface: Surfaced (smooth).

2.4 SHELVING AND CLOTHES RODS

- A. Exposed Shelving: Made from the following material, 3/4 inch thick:
 - 1. MDF panel with PLAM on exposed surfaces, and PVC T-mold edges.
- B. Shelf Brackets with and without Rod Support: BHMA A156.16, prime-painted formed steel.
 - 1. Manufacturers: Subject to compliance with requirements, provide products from the following:
 - a. A&M Hardware, Inc.
 - b. EPCO, Engineered Products Co.
 - c. Knape & Vogt Manufacturing Company.
- C. Metal Clothes Rods: BHMA A156.16, L03131; nominal 1-1/4 inch diameter, chrome-plated-steel tubes with minimum 0.120 inch wall thickness.
- D. Metal Rod Flanges: Chrome-plated steel. Sized to fit closet rods.
- E. Intermediate Closet Rod Support: Heavy-duty, non-adjustable shelf and rod bracket.
 - 1. Size: 12-1/2 inches long by 9-1/2 inches high by 1 inch wide.
 - 2. Maximum Rod Size: 1-3/8 inch.
 - 3. Load Capacity: 250 lbs.
 - 4. Color: White.

2.5 SHELF STANDARDS AND BRACKETS

- A. Adjustable Shelf Standards and Shelf Rests: BHMA A156.9, B04071; with shelf rests, B04081.
1. Shelf Pilaster Standards: Recess-mounted, zinc-plated, cold rolled steel with 1/2 inch on-center vertical adjustments:
 - a. Products: Subject to compliance with requirements, provide one of the following:
 - 1) Knape & Vogt Manufacturing Company: 255 ZC Pilaster Standards.
 - 2) Richelieu: 62162552G Series.
 - 3) Approved substitution.
 - b. Material: Minimum 0.028 inch thick high-strength steel.
 - c. Dimensions: 5/8 inch wide by 3/16 inch deep.
 2. Pilaster Shelf Clips:
 - a. Products: Subject to compliance with requirements, provide one of the following:
 - 1) Knape & Vogt Manufacturing Company: 256 ZC Pilaster Standards.
 - 2) Richelieu: 256BBLZC.
 - 3) Approved substitution.
 - b. Material: Minimum 0.028 inch thick high-strength steel.
 3. Finish: Zinc-plated cold rolled steel.
- B. Heavy-Duty Standards and Brackets: BHMA A156.9, B04102.
1. Standards: Surface-mounted, anochrome-plated, cold rolled steel with 2 inch on-center vertical adjustments:
 - a. Products: Subject to compliance with requirements, provide one of the following:
 - 1) Knape & Vogt Manufacturing Company: 87 Series Super-Duty Industrial Grade Standards.
 - 2) Richelieu: Series #87.
 - 3) Approved substitution.
 - b. Material: Minimum 0.1094 inch thick high-strength steel.
 - c. Dimensions: 5/8 inch wide by 11/16 inch deep.
 2. Brackets: Heavy-duty steel brackets with molded nylon locking cam that secures bracket to standard.
 - a. Products: Subject to compliance with requirements, provide one of the following:
 - 1) Knape & Vogt Manufacturing Company: 187 Series Super-Duty Industrial Grade Brackets.
 - 2) Richelieu: Series #87.
 - 3) Approved substitution.
 - b. Material: Minimum 0.1094 inch thick high-strength steel.
 - c. Dimensions: 5/8 inch wide by 3/16 inch deep.
 - d. Provide manufacturer's compatible shelf rests and rubber.

2.6 MISCELLANEOUS MATERIALS

- A. Fasteners for Interior Finish Carpentry: Nails, screws, and other anchoring devices of type, size, material, and finish required for application indicated to provide secure attachment, concealed where possible.

2.7 GLUES AND ADHESIVES

- A. General: Unless indicated otherwise, comply with the following:
1. Verify adhesives comply with testing and product requirements of California Department of Public Health's "Standard Method for the Testing and Evaluation of Volatile Organic Chemical Emissions from Indoor Sources Using Environmental Chambers."
- B. Glue: Aliphatic-resin, polyurethane, or resorcinol wood glue recommended by manufacturer for general carpentry use.
1. Verify adhesives have a VOC content of 30 g/L or less.

- C. Multipurpose Construction Adhesive: Formulation, complying with ASTM D3498, that is recommended for indicated use by adhesive manufacturer.
 - 1. Verify adhesives have a VOC content of 70 g/L or less.

2.8 FABRICATION

- A. Back out or kerf backs of the following members, except those with ends exposed in finished Work:
 - 1. Interior standing and running trim, except shoe and crown molds.
- B. Ease edges of lumber less than 1 inch in nominal thickness to 1/16 inch radius and edges of lumber 1 inch or more in nominal thickness to 1/8 inch radius.

PART 3 - EXECUTION

3.1 EXAMINATION

- A. Examine substrates, with Installer present, for compliance with requirements for installation tolerances and other conditions affecting performance of Work.
- B. Examine finish carpentry materials before installation. Reject materials that are wet, moisture damaged, and mold damaged.
- C. Proceed with installation only after unsatisfactory conditions have been corrected.

3.2 PREPARATION

- A. Clean substrates of projections and substances detrimental to application.
- B. Before installing interior finish carpentry, condition materials to average prevailing humidity in installation areas for a minimum of 24 hours unless longer conditioning is recommended by manufacturer.

3.3 INSTALLATION, GENERAL

- A. Do not use materials that are unsound; warped; improperly treated or finished; inadequately seasoned; too small to fabricate with proper jointing arrangements; or with defective surfaces, sizes, or patterns.
- B. Install interior finish carpentry level, plumb, true, and aligned with adjacent materials.
 - 1. Use concealed shims where necessary for alignment.
 - 2. Scribe and cut interior finish carpentry to fit adjoining Work. Refinish and seal cuts as recommended by manufacturer.
 - 3. Where face fastening is unavoidable, countersink fasteners, fill surface flush, and sand unless otherwise indicated.
 - 4. Install to tolerance of 1/8 inch in 96 inches for level and plumb. Install adjoining interior finish carpentry with 1/32 inch maximum offset for flush installation and 1/16 inch maximum offset for reveal installation.
 - 5. Coordinate interior finish carpentry with materials and systems in or adjacent to it. Provide cutouts for mechanical and electrical items that penetrate interior finish carpentry.

3.4 INSTALLATION OF STANDING AND RUNNING TRIM

- A. Install trim with minimum number of joints as is practical, using full-length pieces from maximum lengths of lumber available.
 - 1. Do not use pieces less than 24 inches long, except where necessary.
 - 2. Stagger joints in adjacent and related standing and running trim.

3. Miter at returns, miter at outside corners, and cope at inside corners to produce tight-fitting joints with full-surface contact throughout length of joint.
4. Use scarf joints for end-to-end joints.
5. Install trim after gypsum-board joint finishing operations are completed.
6. Install without splitting; drill pilot holes before fastening where necessary to prevent splitting.
7. Fasten to prevent movement or warping.
8. Countersink fastener heads on exposed carpentry Work and fill holes.

3.5 INSTALLATION OF SHELVING AND CLOTHES RODS

- A. Install shelf brackets according to manufacturer's written instructions, spaced not more than 32 inches on center. Fasten to framing members, blocking, or metal backing, or use toggle bolts or hollow wall anchors.
- B. Cut shelves to neatly fit openings with only enough gap to allow shelves to be removed and reinstalled.
 1. Fasten shelves to brackets to comply with bracket manufacturer's written instructions.
- C. Install rod flanges for rods as indicated.
 1. Fasten to shelf cleats, framing members, blocking, or metal backing, or use toggle bolts or hollow wall anchors.
 2. Install rods in rod flanges.

3.6 INSTALLATION OF SHELF STANDARDS AND BRACKETS

- A. Install standards for adjustable shelf supports according to manufacturer's written instructions. Fasten to framing members, blocking, or metal backing, or use toggle bolts or hollow wall anchors.
 1. Space standards not more than 32 inches on center.
 2. Space fasteners not more than 12 inches on center.
- B. Cut shelves to neatly fit openings with only enough gap to allow shelves to be removed and reinstalled.
 1. Install shelves, fully seated on shelf supports.

3.7 ADJUSTING AND CLEANING

- A. Replace interior finish carpentry that is damaged or does not comply with requirements.
 1. Interior finish carpentry may be repaired or refinished if Work complies with requirements and shows no evidence of repair or refinishing.
- B. Adjust joinery for uniform appearance.
- C. Clean interior finish carpentry on exposed and semiexposed surfaces.
- D. Restore damaged or soiled areas and touch up factory-applied finishes if any.

3.8 PROTECTION

- A. Protect installed products from damage from weather and other causes during construction.
- B. Remove and replace finish carpentry materials that are wet, moisture damaged, and mold damaged.
 1. Indications that materials are wet or moisture damaged include discoloration, sagging, or irregular shape.
 2. Indications that materials are mold damaged include fuzzy or splotchy surface contamination and discoloration.

END OF SECTION 062023

SECTION 064023
INTERIOR ARCHITECTURAL WOODWORK

PART 1 - GENERAL

1.1 SUMMARY

- A. Section Includes:
 - 1. Interior frames and jambs.
 - 2. Interior stairs and railings.
 - 3. Wood furring, blocking, shims, and hanging strips for installing interior architectural woodwork items that are not concealed within other construction.
- B. Related Requirements:
 - 1. Section 062023 – Interior Finish Carpentry.

1.2 ADMINISTRATIVE REQUIREMENTS

- A. Coordination:
 - 1. Coordinate sizes and locations of framing, blocking, furring, reinforcements, and other related units of Work specified in other Sections, to ensure that interior architectural woodwork can be supported and installed as indicated.
- B. Preinstallation Meetings: Conduct meeting at Project site.

1.3 ACTION SUBMITTALS

- A. Product Data: For the following:
 - 1. Anchors.
 - 2. Adhesives.
 - 3. Shop finishing materials.
- B. Sustainable Design Submittals:
 - 1. Environmental Product Declaration (EPD): For each product.
 - 2. Chain-of-Custody Certificates: For certified wood products. Include statement of costs.
 - 3. Chain-of-Custody Qualification Data: For manufacturer and vendor.
 - 4. Laboratory Test Reports: For composite wood products, indicating compliance with requirements for low-emitting materials.
 - 5. Product Data: For installation adhesives, indicating VOC content.
 - 6. Laboratory Test Reports: For installation adhesives, indicating compliance with requirements for low-emitting materials.
- C. Shop Drawings:
 - 1. Include dimensioned plans, elevations, and sections, and attachment details.
 - 2. Show large-scale details of fabricated items at a minimum 1 inch:1 foot.
 - 3. Show locations and sizes of furring, blocking, and hanging strips, including blocking and reinforcement concealed by construction and specified in other Sections.
 - 4. Apply AWI Quality Certification label to Shop Drawings.
- D. Samples for Verification: For the following:
 - 1. Lumber for Transparent Finish: Not less than 5 inches wide by 12 inches long, for each species and cut, finished on 1 side and 1 edge.
 - 2. Veneer Leaves: Representative of and selected from flitches to be used for transparent-finished interior architectural woodwork.

3. Lumber and Panel Products with Shop-Applied Opaque Finish: 8 inches wide by 10 inches long for lumber and for panels, for each finish system and color.
 - a. Finish 1/2 of exposed surface.

1.4 INFORMATIONAL SUBMITTALS

- A. Qualification Data: For Installer and fabricator.
- B. Product Certificates: For each type of product.

1.5 CLOSEOUT SUBMITTALS

- A. Quality Standard Compliance Certificates: AWI Quality Certification .

1.6 QUALITY ASSURANCE

- A. Manufacturer's Qualifications: Employs skilled workers who custom fabricate products similar to those required for this Project and whose products have a record of successful in-service performance.
 1. Manufacturer's Certification: Licensed participant in AWI Quality Certification Program (QCP).
- B. Installer Qualifications: Manufacturer of products and licensed participant in AWI's Quality Certification Program (QCP).
- C. Mockups: Build mockups to verify selections made under Sample submittals, to demonstrate aesthetic effects, and to set quality standards for materials and execution.
 1. Build mockups of typical interior architectural woodwork as shown on Drawings.
 2. Approval of mockups does not constitute approval of deviations from Contract Documents contained in mockups unless Owner specifically approves such deviations by Change Order.
 3. Subject to compliance with requirements, approved mockups may become part of completed Work if undisturbed at time of Substantial Completion.

1.7 DELIVERY, STORAGE, AND HANDLING

- A. Comply with referenced woodworking standards.
- B. Do not deliver interior architectural woodwork until painting and similar finish operations that might damage woodwork have been completed in installation areas.
- C. Store woodwork in installation areas or in areas where environmental conditions comply with requirements specified in "Field Conditions" Article.
 1. Handle and store fire-retardant-treated wood to comply with chemical treatment manufacturer's written instructions.

1.8 FIELD CONDITIONS

- A. Environmental Limitations: Do not deliver or install interior architectural woodwork until building is enclosed, wet-Work is complete, and HVAC system is operating and maintaining temperature and relative humidity at levels designed for building occupants for remainder of construction period.
- B. Field Measurements: Where interior architectural woodwork is indicated to fit to other construction, verify dimensions of other construction by field measurements before fabrication, and indicate measurements on Shop Drawings.
 1. Locate concealed framing, blocking, and reinforcements that support woodwork by field measurements before being concealed by construction, and indicate measurements on Shop Drawings.

- C. Established Dimensions: Where interior architectural woodwork is indicated to fit to other construction, establish dimensions for areas where woodwork is to fit. Provide allowance for trimming at site, and coordinate construction to ensure that actual dimensions correspond to established dimensions.

PART 2 - PRODUCTS

2.1 FABRICATORS

- A. Fabricators: Subject to compliance with requirements, provide products by one of the following:
 - 1. Advanced Custom Cabinets.
 - 2. Central Cabinet Systems, a division of Frontier Door & Cabinet.
 - 3. Creoworks.
 - 4. Custom Interiors.
 - 5. Genothen.
 - 6. ISEC.
 - 7. Northwest Millwork.
 - 8. Old Mill Cabinets and Millwork.
 - 9. Pacific Cabinets, Inc.
 - 10. Skagit Architectural Millwork.
 - 11. Approved substitutions.
- B. Source Limitations: Firm engaged to assume responsibility for production of interior architectural woodwork shall be responsible for the following:
 - 1. Section 062023 – Interior Finish Carpentry.
 - 2. Section 064100 – Architectural Wood Casework.

2.2 PERFORMANCE CRITERIA

- A. Fire-Rated Frames: Complying with NFPA 80 and listed and labeled by a qualified testing agency acceptable to authorities having jurisdiction for fire-protection ratings indicated on Drawings, based on testing at positive pressure according to NFPA 252 or UL 10C.
 - 1. Smoke- and Draft-Control Assemblies: Listed and labeled for smoke and draft control by a qualified testing agency acceptable to authorities having jurisdiction, based on testing according to UL 1784 and installed in compliance with NFPA 105.
- B. Fire-Rated, Borrowed-Lite Assemblies: Complying with NFPA 80 and listed and labeled by a qualified testing agency acceptable to authorities having jurisdiction, for fire-protection ratings indicated, based on testing according to NFPA 257 or UL 9.

2.3 ARCHITECTURAL WOODWORK, GENERAL

- A. Quality Standard: Unless otherwise indicated, comply with AWS (Architectural Woodwork Standards) or NAAWS (North American Architectural Woodwork Standards) for grades of interior architectural woodwork indicated for construction, finishes, installation, and other requirements.
 - 1. Provide inspections of fabrication and installation together with labels and certificates from AWI or WI certification program indicating that woodwork complies with requirements of grades specified.
 - 2. Contract Documents may contain requirements that are more stringent than referenced woodwork quality standard. Comply with requirements of Contract Documents in addition to those of referenced quality standard.
- B. Certified Wood: Wood products shall be certified as "FSC Pure" according to FSC STD-01-001 and FSC STD-40-004.

2.4 INTERIOR STANDING AND RUNNING TRIM FOR TRANSPARENT FINISH

- A. Interior Trim: Specified in Section 062023 – Interior Finish Carpentry.

2.5 INTERIOR FRAMES AND JAMBS FOR OPAQUE FINISH

- A. Architectural Woodwork Standards Grade: Custom.
 - 1. Wood Species: Any closed-grain hardwood.
 - 2. Wood Moisture Content: 5 to 10 percent.
- B. Fire-Rated Interior Frames and Jambs: Products fabricated from fire-retardant MDF and listed and labeled by a testing and inspecting agency acceptable to authorities having jurisdiction, for fire ratings indicated, based on testing according to NFPA 252.
 - 1. Fire Rating: 20 minutes.

2.6 INTERIOR WOOD STAIRS AND RAILINGS

- A. Architectural Woodwork Standards Grade: Custom.
- B. Wood for Transparent Finish:
 - 1. Species and Cut: Red oak, plain sawn, unless indicated otherwise.
 - 2. Wood Moisture Content: 5 to 10 percent.
- C. Rough Carriages for Stairs: Laminated veneer lumber, made with an exterior-type adhesive complying with ASTM D2559, and with the following allowable design values as determined according to ASTM D5456:
 - 1. Extreme Fiber Stress in Bending, Edgewise: **[3,100 psi] [2,900 psi] [2,600 psi] [2,250 psi]** for 12 inch nominal-depth members.
 - 2. Modulus of Elasticity, Edgewise: **[2,000,000 psi] [1,800,000 psi] [1,500,000 psi]**.
- D. Finishes for Stair Parts: Transparent, unless indicated otherwise.
- E. Handrail Brackets: Cast aluminum or stainless steel with wall flange drilled for exposed anchor and with support arm for screwing to underside of rail. Size to provide 1-1/2 inch clearance between handrail and face of wall.
- F. Handrail/Bumper Rail Brackets: Pairs of extruded-aluminum channels: one for fastening to back of rail and one for fastening to face of wall, assembled in overlapping fashion and fastened together at top and bottom with self-tapping screws. Size to provide 1-1/2 inch clearance between handrail and wall.

2.7 HARDWOOD SHEET MATERIALS

- A. Composite Wood and Agrifiber Products: Provide materials that comply with requirements of referenced quality standard for each type of architectural cabinet and quality grade specified unless otherwise indicated.
 - 1. Recycled Content of MDF: Postconsumer recycled content plus 1/2 of preconsumer recycled content not less than 90 percent.
- B. Composite Wood Products: Products shall be made using ultra-low-emitting formaldehyde resins as defined in the California Air Resources Board's "Airborne Toxic Control Measure to Reduce Formaldehyde Emissions from Composite Wood Products" or shall be made with no added formaldehyde.
 - 1. Medium-Density Fiberboard (MDF): ANSI A208.2, Grade 130.
 - a. Products: Subject to compliance with requirements, provide one of the following:
 - 1) ampine; Div. of Timber Products Company: Apex MDF.
 - 2) ARAUCO North America: Trupan Standard MDF.
 - 3) Georgia-Pacific Wood Products LLC: UltraStock Premium MDF.

- 4) Roseburg Forest Products Co.: Medite II.
 - 5) Timber Products Company: Masisa Ultralight MDF.
 - 6) West Fraser Timber Co., Ltd.: WestPine EcoGold MDF.
 - 7) Weyerhaeuser Company: Super-Refined MDF2.
2. Softwood Plywood: DOC PS 1, medium-density overlay.

- C. Verify adhesives comply with testing and product requirements of California Department of Public Health's "Standard Method for the Testing and Evaluation of Volatile Organic Chemical Emissions from Indoor Sources Using Environmental Chambers."

2.8 MISCELLANEOUS MATERIALS

- A. Furring, Blocking, Shims, and Nailers: Softwood or hardwood lumber, kiln-dried to less than 15 percent moisture content.
1. Fire-Retardant Treatment: Complying with requirements; provide where indicated. Provide fire-retardant-treated softwood lumber when required by AHJ.
- B. Provide self-drilling screws for metal-framing supports, as recommended by metal-framing manufacturer.
- C. Anchors: Select material, type, size, and finish required for each substrate for secure anchorage.
1. Provide metal expansion sleeves or expansion bolts for post-installed anchors.
 2. Use nonferrous-metal or hot-dip galvanized anchors and inserts at inside face of exterior walls and at floors.
- D. Installation Adhesive: Product recommended by fabricator for each substrate for secure anchorage.
1. Verify adhesives have a VOC content of 70 g/L or less.
 2. Verify adhesives comply with testing and product requirements of California Department of Public Health's "Standard Method for the Testing and Evaluation of Volatile Organic Chemical Emissions from Indoor Sources Using Environmental Chambers."

2.9 FABRICATION

- A. Sand fire-retardant-treated wood lightly to remove raised grain on exposed surfaces before fabrication.
- B. Fabricate interior architectural woodwork to dimensions, profiles, and details indicated.
1. Ease edges to radius indicated for the following:
 - a. Edges of Solid-Wood (Lumber) Members: 1/16 inch unless otherwise indicated.
 - b. Edges of Rails and Similar Members More Than 3/4 Inch Thick: 1/8 inch.
- C. Complete fabrication, including assembly, to maximum extent possible before shipment to Project site.
1. Disassemble components only as necessary for shipment and installation.
 2. Where necessary for fitting at site, provide allowance for scribing, trimming, and fitting.
 3. Trial fit assemblies at fabrication shop that cannot be shipped completely assembled.
 - a. Install dowels, screws, bolted connectors, and other fastening devices that can be removed after trial fitting.
 - b. Verify that parts fit as intended, and check measurements of assemblies against field measurements indicated on approved Shop Drawings before disassembling for shipment.
- D. Stairs: Cut rough carriages to accurately fit treads and risers.
1. Glue treads to risers, and glue and nail treads and risers to carriages.
 2. Fabricate stairs with treads and risers no more than 1/8 inch from indicated position and no more than 1/16 inch out of relative position for adjacent treads and risers.

2.10 SHOP PRIMING

- A. Preparations for Finishing: Comply with referenced quality standard for sanding, filling countersunk fasteners, sealing concealed surfaces, and similar preparations for finishing interior architectural woodwork, as applicable to each unit of work.
- B. Interior Architectural Woodwork for Opaque Finish: Shop prime with 1 coat of wood primer as specified in Section 099000 –Painting and Coating.
 - 1. Backpriming: Apply 1 coat of primer, compatible with finish coats, to concealed surfaces of woodwork. Apply 2 coats to surfaces installed in contact with concrete or masonry and to end-grain surfaces.
- C. Interior Architectural Woodwork for Transparent Finish: Shop-seal concealed surfaces with required pretreatments and first coat of finish as specified in Part 3, Transparent Finish.
 - 1. Backpriming: Apply 1 coat of sealer, compatible with finish coats, to concealed surfaces of woodwork. Apply 2 coats to surfaces installed in contact with concrete or masonry and to end-grain surfaces.

2.11 SHOP FINISHING

- A. Finish interior architectural woodwork with transparent finish at fabrication shop. Defer only final touchup, cleaning, and polishing until after installation.
- B. Preparation for Finishing: Comply with Architectural Woodwork Standards, Section 5 for sanding, filling countersunk fasteners, sealing concealed surfaces, and similar preparations for finishing interior architectural woodwork, as applicable to each unit of Work.
 - 1. Backpriming: Apply 1 coat of sealer or primer, compatible with finish coats, to concealed surfaces of interior architectural woodwork. Apply 2 coats to end-grain surfaces.
- C. Transparent Finish:
 - 1. Architectural Woodwork Standards Grade: Custom.
 - 2. Finish: System – 11, Polyurethane, Catalyzed.
 - 3. Wash Coat for Closed-Grain Woods: Apply wash-coat sealer to cabinets made from closed-grain wood before staining and finishing.
 - 4. Staining: As selected by Architect.
 - 5. Open Finish for Open-Grain Woods: Do not apply filler to open-grain woods.
 - 6. Sheen: Satin, 31-45 gloss units measured on 60 degree gloss meter per ASTM D523.

PART 3 - EXECUTION

3.1 PREPARATION

- A. Before installation, condition interior architectural woodwork to humidity conditions in installation areas for not less than 72 hours prior to beginning of installation.
- B. Before installing interior architectural woodwork, examine shop-fabricated Work for completion and complete Work as required, including removal of packing and backpriming of concealed surfaces.

3.2 INSTALLATION

- A. Grade: Install interior architectural woodwork to comply with same grade as item to be installed.
- B. Assemble interior architectural woodwork and complete fabrication at Project site to extent that it was not completed during shop fabrication.

- C. Install interior architectural woodwork level, plumb, true in line, and without distortion.
 - 1. Shim as required with concealed shims.
 - 2. Install level and plumb to a tolerance of 1/8 inch in 96 inches.
- D. Scribe and cut interior architectural woodwork to fit adjoining Work, refinish cut surfaces, and repair damaged finish at cuts.
- E. Fire-Retardant-Treated Wood: Install fire-retardant-treated wood to comply with chemical treatment manufacturer's written instructions, including those for adhesives used to install woodwork.
- F. Anchor interior architectural woodwork to anchors or blocking built in or directly attached to substrates.
 - 1. Secure with countersunk, concealed fasteners and blind nailing.
 - 2. Use fine finishing nails or finishing screws for exposed fastening, countersunk and filled flush with interior architectural woodwork.
 - 3. For shop-finished items, use filler matching finish of items being installed.
- G. Stairs: Securely anchor carriages to supporting substrates.
 - 1. Install stairs with treads and risers no more than 1/8 inch from indicated position.
 - 2. Secure with countersunk, concealed fasteners and blind nailing.
 - 3. Use fine finishing nails or finishing screws for exposed fastening, countersunk and filled flush with wood surface.
- H. Railings: Install rails with no more than 1/8 inch in 96 inch variation from a straight line.
 - 1. Stair Rails: Glue and dowel or pin balusters to treads and railings, and railings to newel posts.
 - a. Secure with countersunk, concealed fasteners and blind nailing.
 - b. Use fine finishing nails or finishing screws for exposed fastening, countersunk and filled flush with wood surface.
 - 2. Wall Rails: Support rails on wall brackets securely fastened to wall framing.
 - a. Space rail brackets evenly along run, but not more than 96 inches on center.

3.3 REPAIR AND CLEANING

- A. Repair damaged and defective interior architectural woodwork, where possible, to eliminate functional and visual defects and to result in interior architectural woodwork being in compliance with requirements of referenced quality standard for specified grade.
- B. Where not possible to repair, replace defective woodwork.
- C. Touch up finishing Work specified in this Section after installation of interior architectural woodwork.
 - 1. Fill nail holes with matching filler where exposed.
 - 2. Apply specified finish coats, including stains and paste fillers if any, to exposed surfaces where only sealer/prime coats are shop applied.
- D. Field Finish: See Section 099000 – Painting and Coating for final finishing of installed interior architectural woodwork not indicated to be shop finished.
- E. Clean interior architectural woodwork on exposed and semiexposed surfaces.

3.4 FIELD QUALITY CONTROL

- A. Inspections: Provide inspection of installed Work through AWI's Quality Certification Program (QCP) certifying that woodwork, including installation, complies with requirements of referenced quality standards for specified grade.
 - 1. Inspection entity shall prepare and submit report of inspection.

END OF SECTION 064023

SECTION 064100
ARCHITECTURAL WOOD CASEWORK

PART 1 - GENERAL

1.1 SUMMARY

- A. Section Includes:
 - 1. Wood-veneer-faced architectural cabinets.
 - 2. Wood furring, blocking, shims, and hanging strips for installing architectural casework that are not concealed within other construction.
 - 3. Shop finishing of architectural casework.
- B. Related Requirements:
 - 1. Section 123623.13 – Plastic-Laminate-Clad Countertops.
 - 2. Section 123661.19 – Quartz Agglomerate Countertops.

1.2 ADMINISTRATIVE REQUIREMENTS

- A. Coordination:
 - 1. Coordinate sizes and locations of framing, blocking, furring, reinforcements, and other related units of Work specified in other Sections to support loads imposed by installed and fully loaded casework.
- B. Preinstallation Meetings: Conduct meeting at Project site.

1.3 ACTION SUBMITTALS

- A. Product Data: For each type of product.
 - 1. Include data for fire-retardant treatment from chemical-treatment manufacturer and certification by treating plant that treated materials comply with requirements.
- B. Sustainable Design Submittals:
 - 1. Environmental Product Declaration (EPD): For each product.
 - 2. Chain-of-Custody Certificates: For certified wood products. Include statement of costs.
 - 3. Product Data: For installation adhesives, indicating VOC content.
 - 4. Laboratory Test Reports: For installation adhesives, indicating compliance with requirements for low-emitting materials.
 - 5. Laboratory Test Reports: For composite wood products, indicating compliance with requirements for low-emitting materials.
- C. Shop Drawings:
 - 1. Include plans, sections, details, and attachments to other Work. Detail fabrication and installation, including field joints.
 - 2. Show direction of veining, grain, or other directional pattern.
 - 3. Show large-scale details.
 - 4. Show locations and sizes of furring, blocking, and hanging strips, including concealed blocking and reinforcement specified in other Sections.
 - 5. Show locations and sizes of cutouts and holes for items installed in architectural casework.
 - 6. Apply AWI Quality Certification Program label to Shop Drawings.

- D. Samples for Verification: For the following:
 - 1. Lumber for Transparent Finish: Not less than 5 inches wide by 12 inches long, for each species and cut, finished on one side and one edge.
 - 2. Veneer Leaves: Representative of and selected from flitches to be used for transparent-finished casework.
 - 3. Thermoset Decorative Panels: 12 by 12 inches, for each color, pattern, and surface finish.
 - a. Provide edge banding on one edge.
 - 4. Corner Pieces:
 - a. Cabinet-front frame joints between stiles and rails and at exposed end pieces, 18 inches high by 18 inches wide by 6 inches deep.
 - b. Miter joints for standing trim.
 - 5. Exposed Cabinet Hardware and Accessories: 1 full-size unit for each type and finish.

1.4 INFORMATIONAL SUBMITTALS

- A. Qualification Data: For manufacturer and Installer.
- B. Product Certificates: For the following:
 - 1. Composite wood products.
 - 2. Adhesives.
- C. Evaluation Reports: For fire-retardant-treated materials, from ICC-ES.

1.5 CLOSEOUT SUBMITTALS

- A. Quality Standard Compliance Certificates: AWI Quality Certification Program (QCP) certificates.
- B. Maintenance Data: For quartz agglomerate material to include in maintenance manuals. Include Product Data for care products used or recommended by Installer and names, addresses, and telephone numbers of local sources for products.

1.6 QUALITY ASSURANCE

- A. Manufacturer's Qualifications: Company specializing in fabricating products specified in this Section with minimum 5 years of documented experience.
 - 1. Company with at least 5 projects in the past 5 years with value of woodwork within 20 percent of cost of woodwork for this Project.
 - 2. Manufacturer's Certification: Licensed participant in AWI Quality Certification Program (QCP).
- B. Installer Qualifications: Fabricator of products and licensed participant in AWI's Quality Certification Program (QCP).
- C. Mockups: Build mockups to verify selections made under Sample submittals, to demonstrate aesthetic effects, and to set quality standards for materials and execution.
 - 1. Build mockups of typical architectural casework as shown on Drawings.

1.7 DELIVERY, STORAGE, AND HANDLING

- A. Do not deliver casework until painting and similar finish operations that might damage architectural casework have been completed in installation areas.
- B. Store casework in installation areas or in areas where environmental conditions comply with requirements specified in "Field Conditions" Article.
- C. Keep surfaces of casework covered with protective covering during handling and installation.

1.8 FIELD CONDITIONS

- A. Environmental Limitations: Do not deliver or install casework until building is enclosed, wet Work is complete, and HVAC system is operating and maintaining temperature and relative humidity at levels planned for building occupants during remainder of construction period.
 - 1. Maintain temperature and relative humidity during remainder of construction period in range recommended for Project location by AWI's "Architectural Woodwork Standards."
- B. Established Dimensions: Where casework is indicated to fit to other construction, establish dimensions for areas where casework is to fit. Provide allowance for trimming at site, and coordinate construction to ensure that actual dimensions correspond to established dimensions.
- C. Locate concealed framing, blocking, and reinforcements that support casework by field measurements before enclosing them, and indicate measurements on Shop Drawings.

PART 2 - PRODUCTS

2.1 CABINET MANUFACTURERS

- A. Manufacturers: Subject to compliance with requirements, provide products by one of the following:
 - 1. Advanced Custom Cabinets.
 - 2. Central Cabinet Systems, a division of Frontier Door & Cabinet.
 - 3. Creoworks.
 - 4. Custom Interiors.
 - 5. Genothen.
 - 6. Northwest Millwork.
 - 7. Old Mill Cabinets and Millwork.
 - 8. Pacific Cabinets, Inc.
 - 9. Skagit Architectural Millwork.
 - 10. Approved substitutions.
- B. Source Limitations: Firm engaged to assume responsibility for production of architectural wood casework shall be responsible for the following:
 - 1. Section 062023 – Interior Finish Carpentry.
 - 2. Section 064023 – Interior Architectural Woodwork.

2.2 CABINETS, GENERAL

- A. Quality Standard: Unless otherwise indicated, comply with AWI's "Architectural Woodwork Standards" for grades of interior architectural woodwork indicated for construction, finishes, installation, and other requirements.
 - 1. Provide labels and certificates from AWI certification program indicating that woodwork complies with requirements of grades specified.
 - 2. Contract Documents may contain requirements that are more stringent than referenced woodwork quality standard. Comply with requirements of Contract Documents in addition to those of referenced quality standard.
- B. Certified Wood: Wood products shall be certified as "FSC Pure" according to FSC STD-01-001 and FSC STD-40-004.

2.3 WOOD CASEWORK FOR TRANSPARENT FINISH

- A. Architectural Woodwork Standards Grade: Custom.
- B. Type of Construction: Frameless.

- C. Door and Drawer-Front Style: Flush overlay.
- D. Wood for Exposed Surfaces:
 - 1. Species: Red oak unless indicated otherwise.
 - 2. Cut: Plain sliced/plain sawn.
 - 3. Grain Direction: Vertically for drawer fronts, doors, and fixed panels.
 - 4. Matching of Veneer Leaves: Book match.
 - 5. Veneer Matching within Panel Face: Balance match.
- E. Semiexposed Surfaces:
 - 1. Surfaces Other Than Drawer Bodies: Compatible species to that indicated for exposed surfaces, stained to match.
 - a. Edges of Thermoset Decorative Panel Shelves: PVC or polyester edge banding.
 - 2. Drawer Subfronts, Backs, and Sides: Thermoset decorative panels with PVC or polyester edge banding.
 - 3. Drawer Bottoms: Thermoset decorative panels.
- F. Drawer Construction: Fabricate with exposed fronts fastened to subfront with mounting screws from interior of body.
 - 1. Join subfronts, backs, and sides with glued rabbeted joints supplemented by mechanical fasteners.

2.4 WOOD MATERIALS

- A. Wood Products: Provide materials that comply with requirements of referenced quality standard for each type of architectural cabinet and quality grade specified unless otherwise indicated.
 - 1. If using softwood lumber, do not use plain-sawn softwood lumber with exposed, flat surfaces more than 3 inches wide.
 - 2. Wood Moisture Content: 5 to 10 percent.
- B. Composite Wood Products, General: Provide materials that comply with requirements of referenced quality standard for each type of architectural cabinet and quality grade specified unless otherwise indicated.
 - 1. Recycled Content of MDF: Postconsumer recycled content plus 1/2 of preconsumer recycled content not less than 90 percent.
 - 2. Composite Wood Products: Products shall be made using ultra-low-emitting formaldehyde resins as defined in California Air Resources Board's "Airborne Toxic Control Measure to Reduce Formaldehyde Emissions from Composite Wood Products" or shall be made with no added formaldehyde.
 - 3. Medium-Density Fiberboard (MDF): ANSI A208.2, Grade 130.
 - a. Products: Subject to compliance with requirements, provide one of the following:
 - 1) ampine; Div. of Timber Products Company: Apex MDF.
 - 2) ARAUCO North America: Trupan Standard MDF.
 - 3) Georgia-Pacific Wood Products LLC: UltraStock Premium MDF.
 - 4) Roseburg Forest Products Co.: Medite II.
 - 5) Timber Products Company: Masisa Ultralight MDF.
 - 6) West Fraser Timber Co., Ltd.: WestPine EcoGold MDF.
 - 7) Weyerhaeuser Company: Super-Refined MDF2.
 - 4. Softwood Plywood: DOC PS 1, medium-density overlay.

2.5 CASEWORK HARDWARE AND ACCESSORIES

- A. General: Provide casework hardware and accessory materials associated with architectural casework except for items specified in Section 087100 – Door Hardware.
- B. Frameless Concealed Hinges (European Type): BHMA A156.9, B01602, self-closing type, 135 degrees of opening, self-closing with soft-close function.
 - 1. Where indicated, provide hinge manufacturer's opening angle stop designed to limit hinge opening past 86 deg.
- C. Back-Mounted Pulls: BHMA A156.9, B02011; back-mounted, solid metal.
 - 1. Products: Subject to compliance with requirements, provide 102-015-4SC by Olympus Lock, Inc. or approved substitution.
 - a. Profile: Round.
 - b. Diameter: 5/16 inch.
 - c. Mounting Hole CTC: 4 inches.
 - d. Projection: 7/8inch.
 - e. Material: Solid stainless steel.
 - f. Finish: US26D Satin Chromium Plated.
- D. Door and Drawer Locks, General:
 - 1. Standards: Comply with BHMA A156.11, Grade 1.
 - 2. Type: Surface-mounted, sliding deadbolt.
 - 3. Body; Die cast zinc.
 - 4. Overall Size: 1-1/4 inch wide, 1-5/8 inch high, 1/2 inch deep.
 - 5. Cylinder: Solid brass, 5-pin tumbler; re-keyable.
 - 6. Cylinder Length: 7/8 Inch.
 - 7. Cylinder Diameter: 7/8 inch.
 - 8. Deadbolt Size: 3/16 inch thick by 2 inch long.
 - 9. Deadbolt Projection: 3/4 inch.
 - 10. Door Locks: BHMA A156.11, E07121.
 - a. Products: Subject to compliance with requirements, provide one of the following:
 - 1) CompX Security Products: C8173-26D.
 - 2) Olympus Locks, Inc.: 100DR Series.
 - 3) Richelieu: Product No. OL107810126D.
 - 4) Approved substitution.
 - 11. Drawer Locks: BHMA A156.11, E07041.
 - a. Products: Subject to compliance with requirements, provide one of the following:
 - 1) CompX Security Products: C8178-26D.
 - 2) Olympus Locks, Inc.: 200DW Series.
 - 3) Richelieu: Product No. OL207810126D.
 - 4) Approved substitution.
 - 12. Accessories:
 - a. Trim Spacer: Through-bolt using machine screws, reinforcing trim spacer, and through-bolt mount. Do not mount with wood screws.
 - b. Face Plate: Through-bolt using machine screws reinforcing trim spacer, and through-bolt mount. Do not mount with wood screws.
 - c. Elbow Catch: Ives No. 2 Elbow Catch.
 - 1) Install at inactive leaf of double doors where a lock is shown on active leaf.
 - d. Flush Bolt: Ives 262, Flush Bolt.
 - 1) Install at inactive leaf of double doors where a lock is shown on active leaf.
- E. Door and Drawer Silencers: Self-adhering, clear, silicone rubber.
 - 1. Doors: Provide 1 silencer at top and bottom of closing edge of each swinging door.
 - 2. Drawers: Provide 1 silencer on back side of drawer front at each corner.

- F. Surface-Mounted Shelf Brackets: : BHMA A156.9, Grade 2. Heavy-duty wall support.
1. Basis-of-Design Product: Subject to compliance with requirements, provide 208 Series Super-Duty Ultimate L-Bracket by Knape & Vogt Manufacturing Company or approved substitution.
 2. Load Rating: Minimum 1,000 lbs.
 3. Material: Nominal 3/16 by 3/4 inch cold rolled steel.
 4. Size: 12 inch deep by 8 inch high unless indicated otherwise.
 5. Finish: Manufacturer's standard powder coating.
 6. Color: As selected by Architect from manufacturer's color range.
 7. Fasteners: Provide anchors and fasteners appropriate for mounting to scheduled substrate and for securing specified shelving.
- G. Shelf Rests: Clear plastic, for supporting glass shelves at front and rear of brackets; lipped to prevent shelf from shifting.
1. Basis-of-Design Product: Subject to compliance with requirements, provide the following products from Knape & Vogt Manufacturing Company or approved substitution.
 2. Front Left and Right: Model 103 PLAS.
 3. Back: Model 104 PLAS.
- H. Drawer Slides: BHMA A156.9, B05091. Provide drawer slides with soft or quite close functions
1. General: Side mounted; with soft or quite close functions, full-over travel-extension unless indicated otherwise; zinc-plated steel ball-bearing slides, in Grades or load capacities indicated.
 2. Pencil Drawers Slides:
 - a. Load Capacity: 75 lbs.
 - b. Travel: 3/4 extension with hold-out/hold-in detents.
 - c. Mounting: To underside of top surface.
 - d. Drawer Width: Maximum 3 inches high and not more than 24 inches wide.
 3. Pencil Drawers: Plastic, 5-compartment.
 - a. Load Capacity: 75 lbs.
 - b. Size: Nominal 20-1/2 inch wide by 15 inch deep by 2 inch high.
 - c. Color: Black or light grey.
 4. Medium-Duty Drawer Slides: Provide slides with integral stops and stay-closed function.
 - a. Load Capacity: 100 lbs.
 - b. Travel: Full extension plus 1 inch over travel.
 - c. Mounting: Side surfaces.
 - d. Height: More than 3 inches but not more than 6 inches high.
 - e. Width Up to 24 inches.
 - f. Disconnect Types:
 - 1) Lever for widths up to 16 inches.
 - 2) Rail for more than 16 inch and not more than 24 inches wide.
 5. Heavy-Duty File Drawer Slides:
 - a. Load Capacities:
 - 1) Up to 24 Inches Wide 150 lbs.
 - 2) 24 to 42 Inches Wide: 200 lbs.
 - b. Travel: Full extension plus 1-1/2 inch over travel.
 - c. Mounting: Side surfaces.
 - d. Size: More than 6 inches high or more than 24 inches wide.
 - e. Disconnect Type: Rail.
 6. Trash and Recycling Bins:
 - a. Load Capacity: 175 lbs.
 - b. Travel: Full extension plus 1 inch over travel. Self-closing activation at 2-1/2 inches from opening.
 - c. Mounting: Casework floor.
 - d. Size: Not more than 20 inches high and 16 inches wide.
 - e. Disconnect Types: Lever.

- I. Exposed Hardware Finishes: For exposed hardware, provide finish that complies with BHMA A156.18 for BHMA finish number indicated, unless indicated otherwise.
 - 1. Satin Chromium Plated: BHMA 626 for brass or bronze base; BHMA 652 for steel base.
 - 2. Satin Stainless Steel: BHMA 630.
- J. For concealed hardware, provide manufacturer's standard finish that complies with product class requirements in BHMA A156.9.

2.6 MISCELLANEOUS MATERIALS

- A. Furring, Blocking, Shims, and Hanging Strips: Softwood or hardwood lumber, kiln-dried to less than 15 percent moisture content.
 - 1. Provide fire-retardant-treated softwood lumber when required by AHJ.
- B. Anchors: Select material, type, size, and finish required for each substrate for secure anchorage. Provide metal expansion sleeves or expansion bolts for post-installed anchors. Use nonferrous-metal or hot-dip galvanized anchors and inserts at inside face of exterior walls and at floors.
- C. Joint Sealants: Comply with requirements of Section 079200 – Joint Sealants.
 - 1. Verify adhesives have a VOC content of 70 g/L or less.
 - 2. Verify adhesives comply with testing and product requirements of California Department of Public Health's "Standard Method for the Testing and Evaluation of Volatile Organic Chemical Emissions from Indoor Sources Using Environmental Chambers."

2.7 CABINET FABRICATION

- A. Sand fire-retardant-treated wood lightly to remove raised grain on exposed surfaces before fabrication.
- B. Fabricate architectural casework to dimensions, profiles, and details indicated. Ease edges and corners to 1/16 inch radius unless otherwise indicated.
- C. Complete fabrication, including assembly and hardware application, to maximum extent possible before shipment to Project site. Disassemble components only as necessary for shipment and installation. Where necessary for fitting at site, provide ample allowance for scribing, trimming, and fitting.
 - 1. Trial fit assemblies at manufacturer's shop that cannot be shipped completely assembled. Install dowels, screws, bolted connectors, and other fastening devices that can be removed after trial fitting. Verify that various parts fit as intended and check measurements of assemblies against field measurements before disassembling for shipment.
- D. Shop-cut openings to maximum extent possible to receive hardware, appliances, plumbing fixtures, electrical Work, and similar items. Locate openings accurately and use templates or roughing-in diagrams to produce accurately sized and shaped openings. Sand edges of cutouts to remove splinters and burrs.
 - 1. Seal edges of cutouts by saturating with varnish.

2.8 SHOP FINISHING

- A. General: Finish architectural casework at manufacturer's shop as specified in this Section. Defer only final touchup, cleaning, and polishing until after installation.
- B. Preparation for Finishing: Comply with referenced quality standard for sanding, filling countersunk fasteners, sealing concealed surfaces, and similar preparations for finishing architectural cabinets, as applicable to each unit of Work.
 - 1. Backpriming: Apply 1 coat of sealer or primer, compatible with finish coats, to concealed surfaces of cabinets.

- C. Transparent Finish:
 - 1. Architectural Woodwork Standards Grade: Custom.
 - 2. Finish: System – 11, Polyurethane, Catalyzed.
 - 3. Wash Coat for Closed-Grain Woods: Apply wash-coat sealer to cabinets made from closed-grain wood before staining and finishing.
 - 4. Staining: As selected by Architect.
 - 5. Open Finish for Open-Grain Woods: Do not apply filler to open-grain woods.
 - 6. Sheen: Satin, 31-45 gloss units measured on 60 degree gloss meter per ASTM D523.

PART 3 - EXECUTION

3.1 EXAMINATION

- A. Examine substrates to receive casework for conditions under which casework will be installed, with Installer present, for compliance with requirements for installation tolerances and other conditions affecting performance of casework.
- B. Proceed with installation only after unsatisfactory conditions have been corrected.

3.2 PREPARATION

- A. Before installation, condition casework to humidity conditions in installation areas for not less than 72 hours.

3.3 INSTALLATION OF CABINETS

- A. Architectural Woodwork Standards Grade: Install cabinets to comply with quality standard grade of item to be installed.
- B. Assemble cabinets and complete fabrication at Project site to extent that it was not completed in shop.
- C. Anchor cabinets to anchors or blocking built in or directly attached to substrates. Secure with countersunk, concealed fasteners and blind nailing. Use fine finishing nails or finishing screws for exposed fastening, countersunk and filled flush with woodwork.
- D. Install cabinets level, plumb, and true in line to a tolerance of 1/8 inch in 96 inches using concealed shims.
 - 1. Scribe and cut cabinets to fit adjoining Work, refinish cut surfaces, and repair damaged finish at cuts.
 - 2. Install cabinets without distortion so doors and drawers fit openings and are accurately aligned. Adjust hardware to center doors and drawers in openings and to provide unencumbered operation. Complete installation of hardware and accessory items as indicated.
 - 3. Maintain veneer sequence matching of cabinets with transparent finish.
 - 4. Fasten wall cabinets through back, near top and bottom, and at ends not more than 16 inches on center with fasteners appropriate for anchoring to structure.
- E. Shop Finishes: Touch up finishing after installation of architectural cabinets. Fill nail holes with matching filler.
 - 1. Apply specified finish coats, including stains and paste fillers if any, to exposed surfaces where only sealer/prime coats are shop applied.
- F. Field Finishing: See Section 099000 – Painting and Coatings for finishing of installed architectural cabinets.

3.4 FIELD QUALITY CONTROL

- A. Inspections: Provide inspection of installed Work through AWI's Quality Certification Program certifying that woodwork, including installation, complies with requirements of referenced quality standards for specified grade.
 - 1. Inspection entity shall prepare and submit report of inspection.

3.5 REPAIR

- A. Repair damaged and defective casework, where possible, to eliminate functional and visual defects. Where not possible to repair, replace architectural casework. Adjust joinery for uniform appearance.

3.6 FIELD QUALITY CONTROL

- A. Inspections: Provide inspection of installed Work through AWI's Quality Certification Program certifying that woodwork, including installation, complies with requirements of referenced quality standards for specified grade.
 - 1. Inspection entity shall prepare and submit report of inspection.

3.7 ADJUSTING

- A. Adjust hardware so doors and drawers are centered in openings and operate smoothly without warp or bind. Lubricate operating hardware as recommended by manufacturer.

3.8 CLEANING

- A. Clean casework on exposed and semiexposed surfaces. Touch up as required to restore damaged or soiled areas to match original factory finish, as approved by Architect.

END OF SECTION 064100

SECTION 071700
BENTONITE WATERPROOFING

PART 1 - GENERAL

1.1 SUMMARY

- A. Section Includes:
1. Bentonite waterproofing.
 2. Molded-sheet drainage panels.

1.2 ADMINISTRATIVE REQUIREMENTS

- A. Preinstallation Meeting: Conduct meeting at Project.
1. Meeting Time: Schedule meeting a minimum of 2 weeks prior to beginning Work of this Section and related Work.
 2. Require attendance by Architect, Owner, Contractor, Installers, manufacturers' representatives, and other parties directly affecting Work of this Section.
 3. Review bentonite waterproofing requirements including surface preparation, substrate condition and pretreatment, forecasted weather conditions, special details and sheet flashings, installation procedures, testing and inspection procedures, and protection and repairs.

1.3 ACTION SUBMITTALS

- A. Product Data: For each type of product.
1. Include construction details, material descriptions, and installation instructions.
- B. Sustainable Design Submittals:
1. Environmental Product Declaration (EPD): For each product.
 2. Health Product Declaration (HPD): For each product.
- C. Shop Drawings:
1. Include installation details for waterproofing, flashing, penetrations, and interface with other Work.
 - a. Indicate foundation wall to footing transition, inside and outside corner wall, and terminations.
- D. Samples: For each of the following products, in sizes indicated:
1. Waterproofing: 6 inches square.
 2. **[Protection Course: 6 inches square.**
 3.]Molded-Sheet Drainage Panels: 6 inches square.
 4. **[Insulation Drainage Panels: 6 inches square.]**

1.4 INFORMATIONAL SUBMITTALS

- A. Product Certificates: For each type of bentonite waterproofing material.
- B. Qualification Data: For Installer.
- C. Sample Warranty: For manufacturer's special warranty.

1.5 QUALITY ASSURANCE

- A. Installer Qualifications: An entity that employs installers and supervisors who are trained and approved by bentonite waterproofing manufacturer with a minimum of 5 years of experience.
 - 1. Installer shall have not less than 5 waterproofing projects similar to requirements for this Project with satisfactory in-service performance.
- B. Manufacturer Qualifications: Company specializing in manufacturing of bentonite waterproofing components with a minimum of 5 years of experience.
- C. Mockups: Build mockups to set quality standards for fabrication and installation.
 - 1. Build mockup of installation on typical vertical and horizontal surfaces 10 sq. ft. in size.
 - 2. Approval of mockups does not constitute approval of deviations from Contract Documents contained in mockups unless Architect specifically approves such deviations in writing.
 - 3. Subject to compliance with requirements, approved mockups may become part of completed Work if undisturbed at time of Substantial Completion.

1.6 PRECONSTRUCTION TESTING

- A. Preconstruction Testing: Engage a qualified testing agency to perform preconstruction testing on ground water.
 - 1. Obtain 2 liters water of samples from Project site at approximate locations where bentonite waterproofing will be installed.
 - 2. Ship water samples in uncontaminated, sealed, plastic containers. Include on container Project name, city, and state to bentonite waterproofing manufacturer for evaluation.
 - 3. Test water samples for acids, alkalis, brine, or other contaminants that may inhibit performance of bentonite waterproofing materials.
 - 4. Comply with bentonite waterproofing manufacturer's written instructions for testing.
 - 5. Submit manufacturer's test results and bentonite waterproofing manufacturer's product recommendations to Architect and Owner prior to start of bentonite waterproofing installation.

1.7 DELIVERY, STORAGE, AND HANDLING

- A. Delivery and Handling:
 - 1. Deliver waterproofing materials in factory sealed and labeled packaging.
 - 2. Sequence deliveries to avoid delays while minimizing on-site storage.
 - 3. Handle and store waterproofing materials in compliance with waterproofing manufacturer's instructions and recommendations.
 - 4. Remove damaged materials from site and properly dispose of in a legal manner.
- B. Storage:
 - 1. Do not double-stack pallets during shipping or storage.
 - 2. Protect waterproofing materials from moisture, excessive temperatures, sources of ignition, prolonged sunlight, and damage from construction operations.
 - 3. Provide cover, top and all sides, for materials stored on-site, allowing for adequate ventilation.

1.8 FIELD CONDITIONS

- A. Weather Limitations: Proceed with installation only when existing and forecasted weather conditions permit bentonite waterproofing to be installed according to manufacturer's written instructions and warranty requirements.
 - 1. Do not apply bentonite waterproofing materials to surfaces where ice or frost is visible. Do not apply bentonite waterproofing materials in areas with standing water.
 - 2. Do not place bentonite clay products in panel or composite form on damp surfaces unless such practice is approved in writing by manufacturer.

1.9 WARRANTY

- A. Special Warranty: Manufacturer agrees to repair or replace components of bentonite waterproofing system that fail in materials or workmanship within specified warranty period.
 - 1. Warranty Period: 5 years from date of Substantial Completion.

PART 2 - PRODUCTS

2.1 MATERIALS, GENERAL

- A. Source Limitations for Waterproofing System: Obtain bentonite waterproofing materials, protection course, and molded-sheet drainage panels from single source from single manufacturer.

2.2 COMPOSITE POLYETHYLENE/BENTONITE MEMBRANE

- A. Composite Polyethylene/Bentonite Membrane: Dual layer waterproofing membrane consisting of sodium bentonite clay granules heat-fused to layers of HDPE on one side and nonwoven polypropylene geomembrane on the other side.
 - 1. Products: Subject to compliance with requirements, provide one of the following:
 - a. Carlisle Coatings & Waterproofing Inc.: CCW MiraCLAY GM.
 - b. CETCO – Building Materials Group: Voltex DS.
 - c. Henry Company: MiraCLAY.
 - d. Tremco Incorporated: Paraseal GM/LG – 20 mil.
 - e. W. R. Meadows, Inc.: Clay-Tite.
 - f. Approved substitution.
 - 2. Weight: Minimum of 1.0 lb/sq. ft.
 - 3. Grab Tensile Strength: Minimum 120 lbf according to ASTM D 4632.
 - 4. Puncture Resistance: 140 lbf according to ASTM D 4833.
 - 5. Vapor Permeance: 0.03 perms according to ASTM E 96, Procedure B.

2.3 MOLDED-SHEET DRAINAGE PANELS

- A. Molded-Sheet Drainage Panel (MSD.PANEL-2): Composite subsurface drainage panel consisting of a studded, nonbiodegradable, molded-plastic-sheet drainage core; with a nonwoven, needle-punched geotextile facing laminated to one side of core, and acts as protection over waterproofing membrane.
 - 1. Products: Subject to compliance with requirements, provide the following:
 - a. American Hydrotech, Inc.: Hydrodrain 400.
 - b. Carlisle Coatings & Waterproofing Inc.: CCW MiraDRAIN 6000/6200.
 - c. CETCO – Building Materials Group: Aquadrain 15X.
 - d. GCP Applied Technologies Inc.: Hydroduct 200.
 - e. Tremco Incorporated: TREMDrain 1000.
 - f. W. R. Meadows, Inc.: Mel-Drain 5035.
 - g. Approved substitution.
 - 2. Panel Size: 12 inch by 35 foot roll.
 - 3. Core Thickness: ASTM D1777; not less than 0.40 inch.
 - 4. Compressive Strength: ASTM D1621; not less than 15,000 psf.
 - 5. Puncture Resistance: ASTM D3787; 65 lbf.
 - 6. Elongation: ASTM D4632; 50 percent.
 - 7. Apparent Opening Size: ASTM D4751; 70 US std. sieve.
 - 8. Flow Capacity: ASTM D4716; not less than 17 gpm/ft.
 - 9. Panel Orientation: Open core side against waterproofing, filter fabric side out.
 - 10. Application: Vertical and horizontal conditions needing high compressive strength and high flow capacity.

2.4 ACCESSORIES

- A. Granular Bentonite: Sodium bentonite clay containing a minimum of 90 percent montmorillonite (hydrated aluminum silicate), with a minimum of 90 percent passing a No. 20 sieve.
- B. Bentonite Mastic: Bentonite compound of trowelable consistency, specifically formulated for application at joints and penetrations.
- C. Bentonite Tubes: Manufacturer's standard 2-inch-diameter, water-soluble tube containing approximately 1.5 lb/ft. of granular bentonite; hermetically sealed; designed specifically for placing on wall footings at line of joint with exterior base of wall.
- D. Metal Termination Bars: Manufacturer's standard stainless-steel or aluminum bars, pre-drilled at 6 inches on center, installed with noncorrosive fasteners.
 - 1. Size: Minimum 1/8 inch thick by 1 inch wide.
- E. Plastic Protection Sheet: Polyethylene sheeting according to ASTM D 4397; thickness as recommended in writing by waterproofing manufacturer to suit application but at least 6 mils thick.
- F. Cement Grout Patching Material: Grout mix compatible with substrate being patched and recommended in writing by waterproofing manufacturer.
- G. Masonry Fasteners: Case-hardened nails or hardened-steel, powder-actuated fasteners. Depending on manufacturer's written requirements, provide 1/2 or 1 inch diameter washers under fastener heads.
- H. Sealants: As recommended in writing by waterproofing manufacturer. Comply with requirements specified in Section 079200 – Joint Sealants.
- I. Tapes: Waterproofing manufacturer's recommended waterproof tape for joints between sheets, membranes, or panels.
- J. Adhesive: Waterproofing manufacturer's water-based adhesive used to secure waterproofing to both vertical and horizontal surfaces.

PART 3 - EXECUTION

3.1 EXAMINATION

- A. Examine substrates, areas, and conditions, with Installer present, for compliance with requirements for substrate preparations and other conditions affecting performance of bentonite waterproofing.
- B. Examine bentonite materials before installation. Reject materials that have been prematurely exposed to moisture.
- C. Verify that substrate is complete and that Work that will penetrate waterproofing is complete and rigidly installed.
- D. Proceed with installation only after unsatisfactory conditions have been corrected.

3.2 PREPARATION

- A. Clean, prepare, and treat substrates according to manufacturer's written instructions.
- B. Formed Concrete Surfaces: Remove fins and projections. Fill voids, rock pockets, form-tie holes, and other defects with bentonite mastic or cement grout patching material according to manufacturer's written instructions.

- C. Horizontal Concrete Surfaces: Remove debris, standing water, oily substances, mud, and similar substances that could impair bonding ability of concrete or effectiveness of waterproofing. Fill voids, cracks greater than 1/8 inch, honeycomb areas, and other defects with bentonite mastic or cement grout patching material according to manufacturer's written instructions.
- D. Excavation Support and Protection System: If water is seeping, use plastic protection sheets or other suitable means to prevent wetting bentonite waterproofing. Fill minor gaps and spaces 1/8 inch wide or wider with wood, metal, concrete, or other appropriate filling material. Cover or fill large voids and crevices with cement mortar according to manufacturer's written instructions.

3.3 INSTALLATION, GENERAL

- A. Prepare substrates, voids, cracks, and cavities; and install waterproofing and accessories according to manufacturer's written instructions.
 - 1. Before installing, verify correct side of waterproofing that shall face substrate surface.
 - 2. Apply granular bentonite around penetrations in horizontal surfaces and changes in plane according to manufacturer's details in preparation for bentonite tubes and mastic.
 - 3. Apply bentonite tubes, bentonite mastic, or both at changes of plane, construction joints in substrate, projections, and penetrations.
 - 4. Prime concrete substrates. Primer may be omitted on concrete surfaces that comply with manufacturer's written requirements for dryness, surface texture, and freedom from imperfections.
- B. Apply bentonite tubes continuously on footing against base of wall to be waterproofed.
- C. Protect waterproofing from damage and wetting before and during subsequent construction operations. Repair punctures, tears, and cuts.
- D. Install protection course before backfilling or placing overburden when recommended in writing by waterproofing manufacturer.

3.4 INSTALLATION OF GEOTEXTILE/BENTONITE SHEET

- A. Install a continuous layer of waterproofing sheets directly against surface to be waterproofed. Lap ends and edges a minimum of 4 inches on horizontal and vertical substrates unless otherwise indicated. Stagger end joints between sheets a minimum of 24 inches. Fasten seams by stapling to adjacent sheet or nailing to substrate.
- B. Concrete Walls: Starting at bottom of wall, apply waterproofing sheets horizontally against wall. Secure with masonry fasteners spaced according to manufacturer's written instructions. Extend to bottom of footing, grade beam, or wall, and secure.
 - 1. Termination at Grade: Extend waterproofing sheets to within 12 inches of finish grade unless otherwise indicated. Secure top edge with termination bar. Apply sealant to top edge of termination bar.
 - 2. Underslabs: On horizontal surfaces, install waterproofing sheets according to manufacturer's written instructions. Tie horizontal waterproofing sheet to vertical waterproofing sheets as required by waterproofing manufacturer, using corner transition sheets. Secure corner edges of membrane with washer-head fasteners or pneumatic staples at 12 inches on center.

3.5 MOLDED-SHEET DRAINAGE PANEL INSTALLATION

- A. Place and secure molded-sheet drainage panels according to manufacturer's written instructions. Use adhesives or another method that does not penetrate waterproofing. Lap edges and ends of geotextile to maintain continuity. Protect installed molded-sheet drainage panels during subsequent construction.

3.6 FIELD QUALITY CONTROL

- A. Manufacturer's Field Service: Engage a factory-authorized service representative to test and inspect completed waterproofing installation before covering with other construction, and provide written report stating that installation complies with manufacturer's written instructions.
 - 1. Remove and replace applications of bentonite waterproofing where inspection indicates that it does not comply with specified requirements.

END OF SECTION 071700

SECTION 072100
THERMAL INSULATION

PART 1 - GENERAL

1.1 SUMMARY

- A. Section Includes:
 - 1. Extruded polystyrene foam-plastic board insulation.
 - 2. Glass-fiber blanket insulation.
 - 3. Spray foam sealant.
 - 4. Polyethylene vapor retarders.
- B. Products Installed But Not Furnished Under This Section:
 - 1. Section 072119 – Foamed-In-Place Insulation.

1.2 ACTION SUBMITTALS

- A. Product Data: For each type of product.
- B. Sustainable Design Submittals:
 - 1. Product Data: For adhesives, indicating VOC content.
 - 2. Laboratory Test Reports: For adhesives, indicating compliance with requirements for low-emitting materials.
 - 3. Laboratory Test Reports: For insulation, indicating compliance with requirements for low-emitting materials.

1.3 INFORMATIONAL SUBMITTALS

- A. Installer's Certification: Listing type, manufacturer, and R-value of insulation installed in each element of building thermal envelope.
 - 1. Sign, date, and post certification in a conspicuous location on Project site.
- B. Product Test Reports: For each product, for tests performed by a qualified testing agency.
- C. Evaluation Reports: For foam-plastic insulation, from ICC-ES.

1.4 DELIVERY, STORAGE, AND HANDLING

- A. Protect insulation materials from physical damage and from deterioration due to moisture, soiling, and other sources. Store inside and in a dry location. Comply with manufacturer's written instructions for handling, storing, and protecting during installation.
- B. Protect foam-plastic board insulation as follows:
 - 1. Do not expose to sunlight except to necessary extent for period of installation and concealment.
 - 2. Protect against ignition at all times. Do not deliver foam-plastic board materials to Project site until just before installation time.
 - 3. Quickly complete installation and concealment of foam-plastic board insulation in each area of construction.

PART 2 - PRODUCTS

2.1 INSULATION, GENERAL

- A. Insulation shall comply with requirements of California Department of Public Health's "Standard Method for the Testing and Evaluation of Volatile Organic Chemical Emissions from Indoor Sources Using Environmental Chambers."
- B. Recycled Content:
 - 1. Postconsumer recycled content plus 1/2 of preconsumer recycled content not less than the following:
 - a. Extruded Polystyrene Foam-Plastic Board: 50 percent.
 - b. Glass-Fiber Blanket: 50 percent.
 - c. Loose-Fill: 30 percent.
- C. Labeling: Provide identification of mark indicating R-value of each piece of insulation 12 inches and wider in width.

2.2 EXTRUDED POLYSTYRENE FOAM-PLASTIC BOARD INSULATION

- A. Extruded-Polystyrene Board: ASTM C578, unfaced, of type and minimum compressive strength indicated below.
 - 1. Products: Subject to compliance with requirements, provide one of the following:
 - a. DiversiFoam Products: CertiFoam.
 - b. Dow Chemical Company: STYROFOAM Brand XPS.
 - c. Kingspan Insulation Limited: GreenGuard XPS Insulation Board.
 - d. Owens Corning Insulating Systems, LLC: Foamular Extruded Polystyrene Insulation.
 - e. Approved substitution.
 - 2. Thickness: As indicated on Drawings.
 - 3. Board Edges:
 - a. Type IV: Square.
 - b. Type VII: Rabbeted bottom layer; square top layer.
 - 4. Minimum Compressive Strength:
 - a. Type IV: 1.55 pcf density, 25 psi.
 - b. Type VII: 2.20 pcf density, 60 psi.
 - 5. R-Value: 4.20 per inch.
 - 6. Surface-Burning Characteristics: Comply with ASTM E84.
 - a. Flame-Spread Index: 25 or less.
 - b. Smoke-Developed Index: 450 or less.
 - 7. Fire Propagation Characteristics: Passes NFPA 285 testing as part of an approved assembly.
 - 8. Applications:
 - a. Type VII: At exterior plaza decks, protected roof membranes, and where indicated.
 - b. Type IV: Below grade slab edges as detailed.

2.3 GLASS-FIBER BLANKET INSULATION

- A. Glass-Fiber Blanket Insulation, General:
 - 1. Thermal Values: Provide insulation at the following locations with minimum R-Value of 4.5 per inch at 32 degrees F.
 - a. Cavities of 3-1/2 inches: R-15.
 - b. Cavities of 6-1/4 inches: R-19.
 - 2. Surface-Burning Characteristics: Comply with ASTM E84.
 - a. Flame Spread: 25.
 - b. Smoke Developed:
 - 1) Unfaced 50.
 - 2) Faced: 0.

3. Combustibility: Non-combustible when tested according to ASTM E136.
 4. Thermal Resistivity: 4.3 deg F x h x sq. ft./Btu x in. at 75 deg F.
 5. Fire Propagation Characteristics: Passes NFPA 285 testing as part of an approved assembly.
- B. Glass-Fiber Blanket, Unfaced: ASTM C665, Type I.
1. Manufacturers: Subject to compliance with requirements, provide products by one of the following:
 - a. CertainTeed Corporation: CertaPro Sustainable Insulation.
 - b. Johns Manville; a Berkshire Hathaway company: Formaldehyde-free Unfaced Fiberglass
 - c. Owens Corning Insulating Systems, LLC: EcoTouch PINK Fiberglas Insulation.
 - d. Approved substitution.
 2. Applications:
 - a. Exterior stud framed walls.
- C. Glass-Fiber Blanket Insulation, Foil Faced: ASTM C665, Type III (reflective faced), Class A (faced surface with a flame-spread index of 25 or less); Category 1 (membrane is a vapor barrier), faced with foil scrim, foil-scrim kraft, or foil-scrim polyethylene.
1. Products: Subject to compliance with requirements, provide one of the following:
 - a. CertainTeed Corporation: Sustainable Insulation.
 - b. Johns Manville; a Berkshire Hathaway company: ComfortTherm poly-encapsulated thermal and acoustical batts.
 - c. Knauf Insulation: EcoBatt Insulation.
 - d. Owens Corning Insulating Systems, LLC: EcoTouch Flame Spread 25 Fiberglass Insulation.
 - e. Approved substitution.
 2. Surface-Burning Characteristics: Comply with ASTM E84.
 - a. Flame-Spread Index: 25 or less.
 - b. Smoke-Developed Index: 50 or less.
 3. Applications:
 - a. Exposed ceilings under conditioned spaces.

2.4 SPRAY-APPLIED CELLULOSIC INSULATION

- A. Refer to Section 072119 – Foamed-In-Place Insulation.

2.5 INSULATION ATTACHMENT DEVICES

- A. Adhesively Attached, Spindle-Type Insulation Hanger: Plate welded to projecting spindle; capable of holding insulation of specified thickness securely in position indicated with self-locking washer in place.
1. Products: Subject to compliance with requirements, provide one of the following:
 - a. AGM Industries, Inc.: Series T TACTOO Insul-Hangers.
 - b. Gemco: Spindle Type.
 - c. Approved substitution.
 2. Plate: Perforated, galvanized carbon-steel sheet, 0.030 inch thick by 2 inches square.
 3. Spindle: Copper-coated, low-carbon steel; fully annealed; 0.105 inch in diameter; length to suit depth of insulation indicated.
- B. Insulation-Retaining Washers: Self-locking washers formed from 0.016 inch thick galvanized-steel sheet, with beveled edge for increased stiffness, sized as required to hold insulation securely in place, but not less than 1-1/2 inches square or in diameter.
1. Manufacturers: Subject to compliance with requirements, provide products from the following:
 - a. AGM Industries, Inc.
 - b. Gemco.
 - c. Approved substitution.

2. Protect ends with capped self-locking washers incorporating a spring steel insert to ensure permanent retention of cap in the following locations:
 - a. Crawl spaces.
 - b. Ceiling plenums.
 - c. Attic spaces.
 - d. Where indicated.
- C. Insulation Standoff: Fabricated from galvanized mild-steel sheet for fitting over spindle of insulation anchor to maintain air space indicated between face of insulation and substrate to which anchor is attached.
 1. Products: Subject to compliance with requirements, provide one of the following:
 - a. Gemco: Clutch Clip.
 - b. Approved substitution.
- D. Insulation Support Strap: Continuous, galvanized metal support strip, 0.032 inch thickness by 1 inch wide, with approximately 2-1/2 inch long pre-punched arrow shaped tabs at 8 inches on center for impaling insulation.
 1. Products: Subject to compliance with requirements, provide the following:
 - a. J/R Metal Frames Manufacturing, Inc.: Insul-Hold.
 - b. Approved substitution.
- E. Anchor Adhesive: Product with demonstrated capability to bond insulation anchors securely to substrates indicated without damaging insulation, fasteners, and substrates.
 1. Products: Subject to compliance with requirements, provide one of the following:
 - a. AGM Industries, Inc.: TACTOO Adhesive.
 - b. Gemco: Tuff Bond Hanger Adhesive.
 - c. Approved substitution.

2.6 POLYETHYLENE VAPOR RETARDERS

- A. Sheet Vapor Retarder: Polyimide film vapor retarder for use with unfaced, vapor permeable glass fiber and mineral wool insulation in wall and ceiling cavities.
 1. Product: Subject to compliance with requirements, provide the following:
 - a. CertainTeed Corporation: MemBrain.
 - b. Approved substitution.
 2. Thickness: 2 mil.
 3. Water Vapor Permeance: ASTM E96.
 - a. Dry Cup Method: 1.0 perms.
 - b. Wet Cup Method: 10.0 perms.
 4. Surface Burning Characteristics: Class I, Class A ratings according to ASTM E84:
 - a. Flame-Spread Index: 20 or less.
 - b. Smoke-Developed Index: 55 or less.

2.7 INSULATION FOR MISCELLANEOUS VOIDS

- A. Spray Foam Sealant (SF.SLNT-1): Single component, low-pressure, closed cell, polyurethane foam used as an air barrier foam.
 1. Products: Subject to compliance with requirements, provide one of the following:
 - a. Dow Chemical Company: Great Stuff Pro.
 - b. Henkel Corporation: OSI QUAD Foam Window & Door Installation Foam.
 - c. Hilti, Inc.: CF 812 Window and Door Pro.
 - d. Tremco, Inc.: ExoAir FlexFoam.
 2. Applications:
 - a. Sealing perimeters of window and door rough openings in exterior walls.
 - b. Sound-deadening of hollow metal frames.

- B. Spray Foam Sealant (SF.SLNT-2): Single component, closed cell, polyurethane foam.
 - 1. Products: Subject to compliance with requirements, provide one of the following:
 - a. DAP Products, Inc.: Daptex Plus.
 - b. Dow Chemical Company: Great Stuff Pro.
 - c. Soudal: Soudasil.
 - d. WillsealUSA, LLC: Niversal Foam Sealant.
 - e. Approved substitution.
 - 2. Applications: Miscellaneous voids

2.8 ACCESSORIES

- A. Vapor-Retarder Tape: Pressure-sensitive tape of type recommended by vapor-retarder manufacturer for sealing joints and penetrations in vapor retarder.
- B. Vapor-Retarder Fasteners: Pancake-head, self-tapping steel drill screws; with fender washers.
- C. Adhesive for Bonding Insulation: Product compatible with insulation and air and water barrier materials, and with demonstrated capability to bond insulation securely to substrates without damaging insulation and substrates.
 - 1. Verify adhesives have a VOC content of 70 g/L or less.
 - 2. Verify adhesives comply with testing and product requirements of California Department of Public Health's "Standard Method for the Testing and Evaluation of Volatile Organic Chemical Emissions from Indoor Sources Using Environmental Chambers."

PART 3 - EXECUTION

3.1 INSTALLATION, GENERAL

- A. Comply with insulation manufacturer's written instructions applicable to products and applications.
- B. Install insulation that is undamaged, dry, and unsoiled and that has not been left exposed to ice, rain, or snow at any time.
- C. Extend insulation to envelop entire area to be insulated. Fit tightly around obstructions and fill voids with insulation. Remove projections that interfere with placement.
- D. Provide sizes to fit applications and selected from manufacturer's standard thicknesses, widths, and lengths. Apply single layer of insulation units unless multiple layers are otherwise shown or required to make up total thickness or to achieve R-value.
- E. Use insulation support straps where indicated on Drawings and to supplement other attachment methods necessitated by Project conditions.

3.2 INSTALLATION OF SLAB INSULATION

- A. On vertical slab edge and foundation surfaces, set insulation units using manufacturer's recommended adhesive according to manufacturer's written instructions. Stagger end joints and tightly butt panel edges in both directions for tight fit.
 - 1. If not otherwise indicated, extend insulation a minimum of 36 inches below exterior grade line.
- B. On horizontal surfaces, loosely lay insulation units according to manufacturer's written instructions. Stagger end joints and tightly butt panel edges in both directions for tight fit.
 - 1. If not otherwise indicated, extend insulation a minimum of 36 inches in from exterior walls.

3.3 INSTALLATION OF FOUNDATION WALL INSULATION

- A. Stagger end joints and tightly butt panel edges in both directions for tight fit. Install foundation insulation using with of the following methods:
 - 1. Anchor Installation: Install board insulation on concrete substrates by adhesively attached, spindle-type insulation anchors as follows:
 - a. Fasten insulation anchors to concrete substrates with insulation anchor adhesive according to anchor manufacturer's written instructions. Space anchors according to insulation manufacturer's written instructions for insulation type, thickness, and application.
 - b. Apply insulation standoffs to each spindle to create cavity width indicated on Drawings between concrete substrate and insulation.
 - c. After adhesive has dried, install board insulation by pressing insulation into position over spindles and securing it tightly in place with insulation-retaining washers, taking care not to compress insulation.
 - d. Where insulation will not be covered by other building materials, apply capped washers to tips of spindles.
 - 2. Adhesive Installation: Install with adhesive or press into tacky waterproofing or dampproofing according to manufacturer's written instructions.

3.4 INSTALLATION OF FRAMED CONSTRUCTION INSULATION

- A. Blanket Insulation: Install in cavities formed by framing members according to the following requirements:
 - 1. Use insulation widths and lengths that fill the cavities formed by framing members. If more than 1 length is required to fill cavities, provide lengths that will produce a snug fit between ends.
 - 2. Place insulation in cavities formed by framing members to produce a friction fit between edges of insulation and adjoining framing members.
 - 3. Maintain 3 inch clearance of insulation around recessed lighting fixtures not rated for or protected from contact with insulation.
 - 4. For wood-framed construction, install blankets according to ASTM C1320 and as follows:
 - a. With faced blankets having stapling flanges, lap blanket flange over flange of adjacent blanket to maintain continuity of vapor retarder once finish material is installed over it.
- B. Vapor-Retarder-Faced Blankets (INSUL-4B): Tape joints and ruptures in vapor-retarder facings, and seal each continuous area of insulation to ensure airtight installation.
 - 1. Exterior Walls: Set units with facing placed toward exterior of construction unless indicated otherwise on Drawings.
 - 2. Interior Walls: Set units with facing toward areas of high humidity unless indicated otherwise on Drawings.
- C. Miscellaneous Voids: Install insulation in miscellaneous voids and cavity spaces where required to prevent gaps in insulation using the following materials:
 - 1. Glass-Fiber Insulation: Compact to approximately 40 percent of normal maximum volume equaling a density of approximately 2.5 lb/cu. ft.
 - 2. Spray Foam Sealant: Apply according to manufacturer's written instructions.
- D. Loose-Fill Insulation: Apply according to ASTM C1015 and manufacturer's written instructions.
 - 1. Level horizontal applications to uniform thickness as indicated, lightly settle to uniform density, but do not compact excessively.
- E. Spray-Applied Cellulosic Insulation: Refer to Section 072119 – Foamed-In-Place Insulation.

3.5 INSTALLATION OF VAPOR RETARDERS ON FRAMING

- A. Place vapor retarders on side of construction indicated on Drawings.
- B. Extend vapor retarders to extremities of areas to protect from vapor transmission. Secure vapor retarders in place with adhesives, vapor retarder fasteners, or other anchorage system as recommended by manufacturer. Extend vapor retarders to cover miscellaneous voids in insulated substrates, including those filled with loose-fiber insulation.
- C. Seal vertical joints in vapor retarders over framing by lapping no fewer than two studs and sealing with vapor-retarder tape according to vapor-retarder manufacturer's written instructions. Locate all joints over framing members or other solid substrates.
- D. Seal joints caused by pipes, conduits, electrical boxes, and similar items penetrating vapor retarders with vapor-retarder tape to create an airtight seal between penetrating objects and vapor retarders.
- E. Repair tears or punctures in vapor retarders immediately before concealment by other Work. Cover with vapor-retarder tape or another layer of vapor retarder.

3.6 PROTECTION

- A. Protect installed insulation from damage due to harmful weather exposures, physical abuse, and other causes.
- B. Provide temporary coverings or enclosures where insulation is subject to abuse and cannot be concealed and protected by permanent construction immediately after installation.
- C. Protect vapor retarders from damage until concealed by permanent construction.

END OF SECTION 072100

SECTION 072119
FOAMED-IN-PLACE INSULATION

PART 1 - GENERAL

1.1 SUMMARY

- A. Section Includes:
1. Closed-cell spray polyurethane foam.

1.2 ACTION SUBMITTALS

- A. Product Data: For each type of product.
- B. Sustainable Design Submittals:
1. Product Data: For recycled content, indicating postconsumer and preconsumer recycled content and cost.
 2. Environmental Product Declaration (EPD): For each product.
 3. Health Product Declaration (HPD): For each product.

1.3 INFORMATIONAL SUBMITTALS

- A. Qualification Data: For Installer.
- B. Product Test Reports: For each product, for tests performed by a qualified testing agency.
- C. Evaluation Reports: For spray-applied polyurethane foam-plastic insulation, from ICC-ES.

1.4 QUALITY ASSURANCE

- A. Installer Qualifications: Authorized representative who is trained and approved by manufacturer.

1.5 DELIVERY, STORAGE, AND HANDLING

- A. Protect insulation materials from physical damage and from deterioration due to moisture, soiling, and other sources. Store inside and in a dry location. Comply with manufacturer's written instructions for handling, storing, and protecting during installation.

PART 2 - PRODUCTS

2.1 CLOSED-CELL SPRAY POLYURETHANE FOAM

- A. Closed-Cell Spray Polyurethane Foam: ASTM C1029, Type II, 2-component, medium-density, spray-applied polyurethane foam insulation.
1. Products: Subject to compliance with requirements, provide one of the following:
 - a. Carlisle Spray Foam Insulation: SealTite PRO Closed Cell.
 - b. Gaco Western LLC: GacoOnePass F1850.
 - c. Icynene Inc.: ProSeal LE.
 - d. Approved substitution.
 2. Closed Cell Content: ASTM D2856; minimum of 90 percent.
 3. Core Density: ASTM D1622; Minimum 1.7 pcf.
 4. Thermal Values: ASTM C518; minimum aged R-value for the following:
 - a. Less Than 4 Inches Thick: 6.8 deg F x h x sq. ft./Btu x in. at 75 deg F.
 5. Vapor Permeance: Not to exceed the following per ASTM E96:
 - a. 1.39 perms at 1 inch thickness.

6. Compressive Strength: ASTM D1621; 27 psi minimum.
7. Air Permeance: Maximum 0.02 cfm/sq. ft. of surface area at 1.57-lbf/sq. ft. pressure difference when tested according to ASTM E2178.
8. Surface-Burning Characteristics: Comply with ASTM E84; testing by qualified testing agency. Identify products with appropriate markings of applicable testing agency.
 - a. Flame-Spread Index: 25 or less.
 - b. Smoke-Developed Index: 450 or less.
9. Fire Propagation Characteristics: Passes NFPA 285 testing as part of an approved assembly.

2.2 MISCELLANEOUS MATERIALS

- A. Primer: Material recommended by insulation manufacturer where required for adhesion of insulation to substrates.

PART 3 - EXECUTION

3.1 PREPARATION

- A. Verify that substrates are clean, dry, and free of substances that are harmful to insulation.
- B. Priming: Prime substrates where recommended by insulation manufacturer. Apply primer to comply with insulation manufacturer's written instructions. Confine primers to areas to be insulated; do not allow spillage or migration onto adjoining surfaces.

3.2 INSTALLATION

- A. Comply with insulation manufacturer's written instructions applicable to products and applications.
- B. Spray insulation to envelop entire area to be insulated and fill voids.
- C. Apply in multiple passes to not exceed maximum thicknesses recommended by manufacturer. Do not spray into rising foam.
- D. Framed Construction: Install into cavities formed by framing members to achieve thickness indicated on Drawings.
- E. Cavity Walls: Install into cavities to thickness indicated on Drawings.
- F. Miscellaneous Voids: Apply according to manufacturer's written instructions.

3.3 PROTECTION

- A. Protect installed insulation from damage due to harmful weather exposures, physical abuse, and other causes.

END OF SECTION 072119

SECTION 072500
WEATHER BARRIERS

PART 1 - GENERAL

1.1 SUMMARY

- A. Section Includes:
 - 1. Building wrap.
 - 2. Drainage material.
- B. Related Requirements:
 - 1. Section 076500 – Flexible Flashing.

1.2 ACTION SUBMITTALS

- A. Product Data: For each type of product.
 - 1. For building wrap, include data on air and water-vapor permeance based on testing according to referenced standards.
- B. Shop Drawings: Show details of building wrap at terminations, openings, and penetrations. Show details of flexible flashing applications.

1.3 INFORMATIONAL SUBMITTALS

- A. Evaluation Reports: For water-resistive barrier and flexible flashing, from ICC-ES.

1.4 WARRANTY

- A. Manufacturer's Product Warranty: To repair or replace weather barrier product that fails in materials within specified warranty period.
 - 1. Warranty Period: 10 years from date of Substantial Completion.

PART 2 - PRODUCTS

2.1 WATER-RESISTIVE BARRIER

- A. Building Wrap: ASTM E1677, Type I air barrier; non-woven, non-perforated polypropylene fabric, UV stabilized; and acceptable to authorities having jurisdiction.
 - 1. Products: Subject to compliance with requirements, provide one of the following:
 - a. Dow Chemical Company: Weathermate Plus Housewrap.
 - b. DuPont Safety & Construction: Tyvek CommercialWrap. .
 - c. VaproShield LLC: WrapShield IT Integrated Tape .
 - d. Approved substitution.
 - 2. Thickness: Nominally 0.020 inch.
 - 3. Tensile Strength: Minimum 65 lbs./30 in. when tested according to ASTM D882, Method A.
 - 4. Water-Vapor Permeance: When tested according to ASTM E96 Method indicated:
 - a. Procedure A; Desiccant Method: Not less than 20 perms.
 - b. Procedure B; Water Method: Not less than 20 perms.
 - 5. Air Permeance, Product: Not more than 0.001 cfm/sq. ft. at 1.57 lbf/sq. ft. when tested in accordance with ASTM E 2178.
 - 6. Air Permeance, Assembly: Not more than 0.04 cfm/sq. ft. at 1.57 lbf/sq. ft. when tested in accordance with ASTM E 2357 and evaluated by ABAA.
 - 7. Allowable UV Exposure Time: Not less than 180 days.

- 8. Surface Burning Characteristics: ASTM E84, Class A.
 - a. Flame Spread: 25.
 - b. Smoke Developed: 25 [**450**].
 - 9. Flame Propagation Test: Materials and construction shall be as tested according to NFPA 285.
 - 10. Weather barrier system to have a VOC content of 30 g/L or less.
- B. Building-Wrap Tape: Pressure-sensitive plastic tape recommended by building-wrap manufacturer for sealing joints and penetrations in building wrap.
- 2.2 FLEXIBLE FLASHING
- A. Specified in Section 076500 – Flexible Flashing.

PART 3 - EXECUTION

3.1 INSTALLATION OF WATER-RESISTIVE BARRIER

- A. Cover exposed exterior surface of sheathing with water-resistive barrier securely fastened to framing immediately after sheathing is installed.
- B. Cover sheathing with water-resistive barrier as follows:
 - 1. Cut back barrier 1/2 inch on each side of the break in supporting members at expansion- or control-joint locations.
 - 2. Apply barrier to cover vertical flashing with a minimum 4 inch overlap unless otherwise indicated.
- C. Building Wrap: Comply with manufacturer's written instructions and warranty requirements.
 - 1. Seal seams, edges, fasteners, and penetrations with tape.
 - 2. Extend into jambs of openings and seal corners with tape.

3.2 INSTALLATION OF FLEXIBLE FLASHING

- A. Apply flexible flashing where indicated to comply with manufacturer's written instructions.
 - 1. Prime substrates as recommended by flashing manufacturer.
 - 2. Lap seams and junctures with other materials at least 4 inches except that at flashing flanges of other construction, laps need not exceed flange width.
 - 3. Lap flashing over water-resistive barrier at bottom and sides of openings.
 - 4. Lap water-resistive barrier over flashing at heads of openings.
 - 5. After flashing has been applied, roll surfaces with a hard rubber or metal roller to ensure that flashing is completely adhered to substrates.

END OF SECTION 072500

SECTION 073013
ROOFING UNDERLAYMENTS

PART 1 - GENERAL

1.1 SUMMARY

- A. Section Includes:
 - 1. Self-adhering sheet underlayment.
 - 2. Synthetic sheet underlayment.

1.2 ACTION SUBMITTALS

- A. Product Data: For each product indicated.
- B. Samples for Verification: 12 inch square Samples for the following products, to verify color selected:
 - 1. Self-adhering underlayment.
 - 2. Synthetic sheet underlayment.

1.3 INFORMATIONAL SUBMITTALS

- A. Qualification Data: For Installer.
- B. Product Test Reports: For each type of underlayment product indicated, for tests performed by manufacturer and witnessed by a qualified testing agency.
- C. Research Reports: For synthetic underlayment, from ICC-ES, indicating that product is suitable for intended use under applicable building codes.
- D. Sample Warranty: For manufacturer's materials warranty.

1.4 QUALITY ASSURANCE

- A. Fire-Test-Response Characteristics: Provide underlayment and related roofing materials with fire-test-response characteristics indicated, as determined by testing identical products per test method below by UL or another testing and inspecting agency acceptable to authorities having jurisdiction. Identify materials with appropriate markings of applicable testing and inspecting agency.
 - 1. Exterior Fire-Test Exposure: Class A; ASTM E108 or UL 790, for application and roof slopes indicated.

1.5 DELIVERY, STORAGE, AND HANDLING

- A. Store underlayment materials in a dry, well-ventilated location protected from weather, sunlight, and moisture in accordance with manufacturer's written instructions.
- B. Store underlayment rolls on end, on pallets or other raised surfaces. Do not double-stack rolls.
- C. Protect unused roofing materials from weather, sunlight, and moisture when left overnight or when roofing Work is not in progress.
- D. Handle, store, and place underlayment materials in a manner to prevent damage to roof deck or structural supporting members.

1.6 FIELD CONDITIONS

- A. Environmental Limitations: Proceed with installation only when existing and forecasted weather conditions permit product installation and related Work to be performed in accordance with manufacturer's written instructions and warranty requirements.
1. Install self-adhering, polymer-modified bitumen sheet underlayment within range of ambient and substrate temperatures recommended in writing by manufacturer.

1.7 WARRANTY

- A. Manufacturer's Warranty: Manufacturer agrees to repair or replace synthetic underlayment that fails within specified warranty period by allowing water to penetrate roofing substrates to which it is applied due to decomposition beneath primary roof covering under which it is installed.
1. Warranty Period: 20 years from date of Substantial Completion.

PART 2 - PRODUCTS

2.1 UNDERLAYMENT MATERIALS

- A. Source Limitations: Obtain underlayments through one source from a single manufacturer.
- B. Self-Adhering, Modified Bitumen Sheet Underlayment (Type 1A): ASTM D1970, cold applied, glass-fiber-mat-reinforced, SBS-modified asphalt; with slip-resistant top surface and release backing. Provide primer for adjoining concrete, masonry, and metal surfaces to receive underlayment.
1. Products: Subject to compliance with requirements, provide one of the following:
 - a. Carlisle Coatings & Waterproofing Inc.: WIP 300HT.
 - b. CertainTeed Corporation: WinterGuard HT.
 - c. Malarkey Roofing Products: 406 SecureStart HT.
 - d. Owens Corning Roofing and Asphalt, LLC: Titanium PSU30.
 - e. Protecto Wrap Company: Protecto Jiffy Seal Ice & Water Guard HT.
 - f. Approved substitution.
 2. Thickness: Minimum of 40 mils.
 3. Service Temperature: Minimum 230 deg F.
 4. Minimum Roof Slope: Do not install on slopes less than 1:12.
 5. Allowable UV Exposure Time: Not less than 120 days.
 6. Thermal Stability: ASTM D1970, stable after testing at 240 deg F.
 7. Low-Temperature Flexibility: ASTM D1970; passes after testing at minus 20 deg F.
- C. Synthetic Sheet Underlayment (Type 2): UV-resistant polypropylene, polyolefin, or polyethylene polymer fabric with surface coatings or treatments to improve traction underfoot and abrasion resistance; evaluated and documented to be suitable for use as a roof underlayment under applicable codes by a testing and inspecting agency acceptable to authorities having jurisdiction.
1. Products: Subject to compliance with requirements, provide one of the following:
 - a. CertainTeed Corporation: DiamondDeck.
 - b. GAF: Tiger Paw Premium Roof Deck Protection.
 - c. Kirsch Building Products, LLC:
 - 1) Metal Roofing: SharkSkin Ultra
 - 2) Asphalt Shingles: SharkSkin Comp.
 - d. Malarkey Roofing Products: 1031 SecureStart Plus.
 - e. Owens Corning Roofing and Asphalt, LLC: Titanium UDL30 or UDL50.
 - f. SPD Advanced Polymer Products, Inc.: Palisade Synthetic Roofing Underlayment
 - g. Approved substitution.
 2. Physical Compliance: Meets requirements of ASTM D226 Types I and II, and ASTM D4869.
 3. Minimum Thickness: 15 mils.
 4. Minimum Weight: 40 lbs./10 squares.

5. Minimum Roof Slope: Do not install on slopes less than 4:12.
6. Allowable UV Exposure Time: Not less than 180 days.
7. Water Transmission: ASTM D4869; passes.
8. Surface Burning: ASTM E108; Class A.

2.2 ACCESSORIES

- A. Asphalt Roofing Cement: ASTM D4586, Type II, asbestos free.
- B. Roofing Nails: ASTM F1667; aluminum, stainless-steel, or hot-dip galvanized steel wire shingle nails, minimum 0.120 inch diameter, barbed shank as recommended by shingle manufacturer, sharp-pointed, with a minimum 3/8 inch diameter flat head and of sufficient length to penetrate 3/4 inch into solid wood decking or extend at least 1/8 inch through OSB or plywood sheathing.
 1. Where nails are in contact with metal flashing, use nails made from same metal as flashing.
- C. Synthetic Underlayment Fasteners: Hot-dip galvanized-steel wire nails with low-profile metal or plastic caps, 1 inch minimum diameter, or as recommended in writing by synthetic-underlayment manufacturer for applications indicated.

PART 3 - EXECUTION

3.1 EXAMINATION

- A. Examine substrates, areas, and conditions, with Installer present, for compliance with requirements for installation tolerances and other conditions affecting performance of Work.
 1. Examine roof sheathing to verify that sheathing joints are supported by framing and blocking and that installation is within flatness tolerances.
 2. Verify that substrate is sound, dry, smooth, clean, sloped for drainage, and completely anchored; and that provision has been made for flashings and penetrations.
- B. Prepare written report, endorsed by Installer, listing conditions detrimental to performance of Work.
- C. Proceed with installation only after unsatisfactory conditions have been corrected.

3.2 INSTALLATION OF UNDERLAYMENT, ASPHALT SHINGLES

- A. Comply with asphalt shingle and underlayment manufacturers' written installation instructions and with recommendations in NRCA's "The NRCA Roofing Manual: Steep-Slope Roof Systems" applicable to products and applications indicated unless more stringent requirements apply. Complete underlayment installation ready to receive Work of Section 073113 – Asphalt Shingles.
- B. Self-Adhering Sheet Underlayment: Install, wrinkle free, on roof deck.
 1. Comply with low-temperature installation restrictions of underlayment manufacturer.
 2. Install lapped in direction that sheds water.
 - a. Lap sides not less than 4 inches.
 - b. Lap ends not less than 6 inches, staggered 24 inches between succeeding courses.
 - c. Roll laps with roller.
 3. Prime concrete, masonry, and metal surfaces to receive self-adhering sheet.
 4. Apply underlayment over roof area indicated below:
 - a. Eaves: Extend from edges of eaves 36 inches beyond interior face of exterior wall.
 - b. Rakes: Extend from edges of rake 36 inches beyond interior face of exterior wall.
 - c. Valleys: Extend from lowest to highest point 18 inches on each side. Overlap ends of sheets not less than 6 inches.
 - d. Hips: Extend 18 inches on each side.
 - e. Ridges: Extend 36 inches on each side without obstructing continuous ridge vent slot.

- f. Sidewalls: Extend beyond sidewall 18 inches, and return vertically against sidewall not less than 4 inches.
 - g. Dormers, Chimneys, Skylights, and Other Roof-Penetrating Elements: Extend beyond penetrating element 18 inches, and return vertically against penetrating element not less than 4 inches.
 - h. Roof Slope Transitions: Extend 18 inches on each roof slope.
 - 5. Cover underlayment within 7 days.
- C. Synthetic Underlayment:
- 1. Install on roof deck parallel with and starting at eaves.
 - a. Lap sides and ends as recommended in writing by manufacturer, but not less than 4 inches for side laps and 6 inches for end laps.
 - b. Stagger end laps between succeeding courses at interval recommended in writing by manufacturer, but not less than 72 inches.
 - c. Fasten with underlayment nails in accordance with manufacturer's written instructions.
 - d. Cover underlayment within period recommended in writing by manufacturer.
 - 2. Install in single layer on roofs sloped at 4:12 and greater.
 - 3. Install in double layer on roofs sloped at less than 4:12, or as required by underlayment manufacture.
 - 4. Install synthetic underlayment on roof deck not covered by self-adhering sheet underlayment unless otherwise specified in this Section or indicated on Drawings.
 - a. Lap sides of underlayment over self-adhering sheet not less than 4 inches in direction to shed water.
 - b. Lap ends of underlayment not less than 6 inches over self-adhering sheet.
 - 5. Install fasteners in a grid pattern of 12 inches between side laps with 6 inch spacing at side and end laps, or as acceptable to AHJ.
 - 6. Terminate synthetic underlayment extended up not less than 4 inches against sidewalls, curbs, and other roof projections.

3.3 INSTALLATION OF UNDERLAYMENT, METAL ROOF PANELS

- A. Comply with metal roofing and underlayment manufacturers' written installation instructions applicable to products and applications indicated unless more stringent requirements apply. Complete underlayment installation ready to receive Work of Section 074113.16 – Standing Seam Metal Roof Panels.
- B. Self-Adhering Sheet Underlayment:
 - 1. Apply primer if required by underlayment manufacturer.
 - 2. Comply with temperature restrictions of underlayment manufacturer for installation.
 - 3. Apply at locations indicated below, unless indicated otherwise, wrinkle free, in shingle fashion to shed water, and with end laps of not less than 6 inches staggered 24 inches between courses.
 - 4. Overlap side edges not less than 3-1/2 inches.
 - 5. Extend underlayment into gutter trough.
 - 6. Roll laps with roller.
 - 7. Cover underlayment within 14 days.
 - 8. Apply over entire roof surface.

3.4 INSTALLATION OF UNDERLAYMENT, SHEET METAL FLASHING

- A. Comply with sheet metal flashing and underlayment manufacturers' written installation instructions applicable to products and applications indicated unless more stringent requirements apply. Complete underlayment installation ready to receive Work of Section 076200 – Sheet Metal Flashing and Trim.

- B. Self-Adhering Sheet Underlayment:
 - 1. Install self-adhering, high-temperature sheet underlayment; wrinkle free.
 - 2. Prime substrate if recommended by underlayment manufacturer.
 - 3. Comply with temperature restrictions of underlayment manufacturer for installation; use primer for installing underlayment at low temperatures.
 - 4. Apply in shingle fashion to shed water, with end laps of not less than 6 inches staggered 24 inches between courses.
 - 5. Overlap side edges not less than 3-1/2 inches. Roll laps and edges with roller.
 - 6. Roll laps and edges with roller.
 - 7. Cover underlayment within 14 days.
 - 8. Apply underneath parapet caps, coping, and other sheet metal flashing systems where indicated on Drawings.

 - C. Synthetic Sheet Underlayment:
 - 1. Install synthetic underlayment, wrinkle free, in accordance with manufacturers' written instructions, and using adhesive where possible to minimize use of mechanical fasteners under sheet metal.
 - 2. Lap horizontal joints not less than 4 inches.
 - 3. Lap end joints not less than 12 inches.
- 3.5 PROTECTION
- A. Protect installed underlayments until installation of roof covering and sheet metal flashing and trim.

END OF SECTION 073013

SECTION 073113
ASPHALT SHINGLES

PART 1 - GENERAL

1.1 SUMMARY

- A. Section Includes:
 - 1. Glass-fiber-reinforced asphalt shingles.
 - 2. Ridge vents.
 - 3. Metal flashing and trim.
- B. Related Requirements:
 - 1. Section 073013 – Roofing Underlayments.

1.2 DEFINITIONS

- A. Roofing Terminology: See ASTM D1079 for definitions of terms related to roofing Work in this Section.

1.3 ADMINISTRATIVE REQUIREMENTS

- A. Pre-Installation Meetings: Conduct meeting at Project site.

1.4 ACTION SUBMITTALS

- A. Product Data: For the following:
 - 1. Asphalt shingles.
 - 2. Ridge vents.
 - 3. Asphalt roofing cement.
 - 4. Elastomeric flashing sealant.
- B. Sustainable Design Submittals:
 - 1. Product Test Reports: For roof materials, documentation indicating that roof materials comply with Solar Reflectance Index requirements.
- C. Shop Drawings: For metal flashing and trim.
- D. Samples for Verification: For each exposed product and for each color and blend specified, in sizes indicated.
 - 1. Asphalt Shingles: Full size.
 - 2. Ridge and Hip Cap Shingles: Full size.
 - 3. Ridge Vent: 12 inch long.
 - 4. Exposed Valley Lining: 12 inches square.

1.5 INFORMATIONAL SUBMITTALS

- A. Qualification Data: For Installer.
- B. Product Test Reports: For each type of asphalt shingle product indicated, for tests performed by manufacturer and witnessed by a qualified testing agency.
- C. Sample Warranty: For manufacturer's materials warranty.

1.6 CLOSEOUT SUBMITTALS

- A. Maintenance Data: For asphalt shingles to include in maintenance manuals.
- B. Materials warranties.
- C. Roofing Installer's warranty.

1.7 MAINTENANCE MATERIAL SUBMITTALS

- A. Furnish extra materials that match products installed and that are packaged with protective covering for storage and identified with labels describing contents.
 - 1. Asphalt Shingles: 100 sq. ft. of each type and in each color and blend, in unbroken bundles.

1.8 QUALITY ASSURANCE

- A. Installer Qualifications: An authorized installer who is trained and approved by manufacturer.

1.9 DELIVERY, STORAGE, AND HANDLING

- A. Store roofing materials in a dry, well-ventilated location protected from weather, sunlight, and moisture in accordance with manufacturer's written instructions.
- B. Protect unused roofing materials from weather, sunlight, and moisture when left overnight or when roofing Work is not in progress.
- C. Handle, store, and place roofing materials in a manner to prevent damage to roof deck or structural supporting members.

1.10 FIELD CONDITIONS

- A. Environmental Limitations: Proceed with installation only when existing and forecasted weather conditions permit product installation and related Work to be performed in accordance with manufacturer's written instructions and warranty requirements.
 - 1. Install sheet underlayment Type 1A within range of ambient and substrate temperatures recommended in writing by manufacturer.

1.11 WARRANTY

- A. Special Project Warranty: Manufacturer's Total System Warranty, on signed form acceptable to Architect and Owner, covering Work of this Section, including components of roofing system indicated as follows:
 - 1. Materials as manufactured or authorized by roofing system manufacturer including underlayments, shingles, flashings, counterflashings, adhesives and sealants, fasteners, sheet metal Work, adhesives, and other products utilized in this installation.
 - 2. Warranty Period: 50 years from date of Substantial Completion.
- B. Materials Warranty: Manufacturer agrees to repair or replace asphalt shingles that fail within specified warranty period.
 - 1. Failures include the following:
 - a. Manufacturing defects.
 - b. Failure of asphalt shingles to self-seal after a reasonable time.
 - 2. Material Warranty Period: 50 years from date of Substantial Completion, prorated, with first 15 years nonprorated.
 - 3. Wind-Speed Warranty Period: Asphalt shingles will resist blow-off or damage caused by wind speeds of up to 130 mph for 15 years from date of Substantial Completion.
 - 4. Workmanship Warranty Period: 2 years from date of Substantial Completion.

- C. Roofing Installer's Warranty: On warranty form signed by Installer, in which Installer agrees to repair or replace components of asphalt-shingle roofing that fail in materials or workmanship within specified warranty period.
 - 1. Warranty Period: 2 years from date of Substantial Completion.

PART 2 - PRODUCTS

2.1 SOURCE LIMITATIONS

- A. Obtain each type of product from single source from single manufacturer.

2.2 PERFORMANCE CRITERIA

- A. Exterior Fire-Test Exposure: Provide asphalt shingles and related roofing materials identical to those of assemblies tested for Class A fire resistance in accordance with ASTM E108 or UL 790 by Underwriters Laboratories or another testing and inspecting agency acceptable to authorities having jurisdiction. Identify products with appropriate markings of applicable testing agency.
- B. Wind Resistance: Provide asphalt shingles that comply with requirements of ASTM D3161, Class F, and with ASTM D7158, Class H.
- C. Energy Performance, ENERGY STAR: Provide asphalt shingles that are listed on DOE's "ENERGY STAR Roof Product List" for steep-slope roof products.
- D. Heat Island Effect - Steep Roof: 3-year-aged SRI not less than 32 or initial SRI not less than 39 when calculated in accordance with ASTM E1980 based on testing identical products by a qualified testing agency.

2.3 GLASS-FIBER-REINFORCED ASPHALT SHINGLES

- A. Laminated-Strip Asphalt Shingles: ASTM D3462, laminated, multi-ply overlay construction; glass-fiber reinforced, mineral-granule surfaced, and self-sealing.
 - 1. Products: Subject to compliance with requirements, provide one of the following:
 - a. Atlas Roofing Corporation: StormMaster Slate.
 - b. CertainTeed Corporation: Northgate AR.
 - c. GAF: Timberline HD.
 - d. Malarkey Roofing Products: Highlander NEX AR].
 - e. Owens Corning Roofing and Asphalt, LLC: TruDefinition Duration Series.
 - f. Approved substitution.
 - 2. Butt Edge: Straight cut.
 - 3. Strip Size: Manufacturer's standard.
 - 4. Algae Resistance: Granules resist algae discoloration.
 - 5. Color and Blends: As selected by Architect from manufacturer's full range.
- B. Hip and Ridge Shingles: Manufacturer's standard units to match asphalt shingles.

2.4 UNDERLAYMENT MATERIALS

- A. Roofing Underlayments: Specified in Section 073013 – Roofing Underlayments.

2.5 RIDGE VENTS

- A. Rigid Ridge Vent: Manufacturer's standard, rigid-section, high-density, UV-stabilized plastic ridge vent for use under ridge shingles.

- B. Rigid Vent: Manufacturer's standard, rigid section, high-density polypropylene or other UV-stabilized plastic ridge vent with nonwoven geotextile filter strips and external deflector baffles; for use under ridge shingles.
 - 1. Manufacturers: Subject to compliance with requirements, provide products by one of the following:
 - a. Air Vent Inc., a CertainTeed Company: ShingleVent II.
 - b. Cor-A-Vent, Inc.: V-Series.
 - c. GAF Materials Corporation: Cobra Rigid Vent II.
 - d. Globe Building Materials, Inc.: SmartAir Ridge Vent.
 - e. Lomanco, Inc.: OR-4.
 - f. Mid-America Building Products: RidgeMaster Plus.
 - g. Owens Corning Roofing and Asphalt, LLC: VentSure Ridge Vent.
 - h. Ridglass Manufacturing Company, Inc.: Coolvent.
 - i. Solar Group, Inc. (The), a Gibraltar Company: PRV4.
 - j. Trimline Building Products: Trimline Ridge Vent.
 - 2. Minimum Net Free Area: <Insert area>.
 - 3. Width: <Insert width>.
 - 4. Thickness: <Insert thickness>.

2.6 ACCESSORIES

- A. Asphalt Roofing Cement: ASTM D4586 Type II, asbestos free.
- B. Elastomeric Flashing Sealant: ASTM C920, Type S, Grade NS, one-part, non-sag, elastomeric polymer sealant; of class and use classifications required to seal joints and remain watertight; recommended in writing by manufacturer for installation of flashing systems.
- C. Roofing Nails: ASTM F1667, Hot-dip galvanized-steel wire shingle nails, minimum 0.120 inch diameter, sharp-pointed, with a 3/8 to 7/16 inch diameter flat head and of sufficient length to penetrate 3/4 inch into solid wood decking or extend at least 1/8 inch through sheathing less than 3/4 inch thick.
 - 1. Where nails are in contact with metal flashing, use nails made from same metal as flashing.
- D. Underlayment Nails: Aluminum, stainless steel, or hot-dip galvanized-steel wire nails with low-profile metal or plastic caps, 1 inch minimum diameter.
 - 1. Provide with minimum 0.0134 inch thick metal cap, 0.010 inch thick power-driven metal cap, or 0.035 inch thick plastic cap; and with minimum 0.083 inch thick ring shank or 0.091 inch thick smooth shank of length to penetrate at least 3/4 inch into roof sheathing or to penetrate through roof sheathing less than 3/4 inch thick.

2.7 METAL FLASHING AND TRIM

- A. Comply with requirements in Section 076200 – Sheet Metal Flashing and Trim.
- B. Fabricate sheet metal flashing and trim to comply with recommendations in SMACNA's "Architectural Sheet Metal Manual" that apply to design, dimensions, metal, and other characteristics of the item unless otherwise specified in this Section or indicated on Drawings.
 - 1. Open-Valley Flashings: Fabricate from metal sheet not less than 24 inches wide in lengths not exceeding 10 feet, with 1 inch high, inverted-V profile water diverter at center of valley and equal flange widths of not less than 11 inches.
 - a. Hem flange edges for fastening with metal cleats.
 - b. Add stiffening ribs in flashings to promote drainage.
 - 2. Drip Edges: Fabricate in lengths not exceeding 10 feet with minimum 2 inch roof-deck flange and 1-1/2 inch fascia flange with 3/8 inch drip at lower edge.
 - 3. Vent-Pipe Flashings: ASTM B749, Type L51121, at least 1/16 inch thick. Provide lead sleeve sized to slip over and turn down into pipe, soldered to skirt at slope of roof, and extending at least 4 inches from pipe onto roof.

PART 3 - EXECUTION

3.1 EXAMINATION

- A. Examine substrates, areas, and conditions, with Installer present, for compliance with requirements for installation tolerances and other conditions affecting performance of the Work.
 - 1. Examine roof sheathing to verify that sheathing joints are supported by framing and blocking or metal clips and that installation is within flatness tolerances.
 - 2. Verify that substrate is sound, dry, smooth, clean, sloped for drainage, and completely anchored and that provisions have been made for flashings and penetrations through asphalt shingles.
 - 3. Verify that vent stacks and other penetrations through roofing are installed and securely fastened.
- B. Prepare written report, endorsed by Installer, listing conditions detrimental to performance of the Work.
- C. Proceed with installation only after unsatisfactory conditions have been corrected.

3.2 INSTALLATION OF UNDERLAYMENT MATERIALS

- A. Install underlayment materials to comply with requirements specified in Section 073013 – Roofing Underlayments.
- B. Metal-Flashed, Open-Valley Underlayment: Install 2 layers of minimum 36 inch wide underlayment centered in valley.
 - 1. Use same underlayment as installed on field of roof.
 - 2. Stagger end laps between layers at least 72 inches.
 - 3. Lap ends of each layer at least 12 inches in direction that sheds water, and seal with asphalt roofing cement.
 - 4. Fasten each layer to roof deck with underlayment nails located as far from valley center as possible and only to extent necessary to hold underlayment in place until installation of valley flashing.
 - 5. Lap roof-deck underlayment over first layer of valley underlayment at least 6 inches.

3.3 INSTALLATION OF METAL FLASHING AND TRIM

- A. Install metal flashings and trim to comply with requirements in Section 076200 – Sheet Metal Flashing and Trim.
 - 1. Install metal flashings in accordance with recommendations in ARMA's "Asphalt Roofing Residential Manual - Design and Application Methods" and NRCA's "NRCA Guidelines for Asphalt Shingle Roof Systems."
 - 2. Bed flanges of metal flashings using asphalt roofing cement or elastomeric flashing sealant.
- B. Open-Valley Flashings: Install centered in valleys, lapping ends at least 8 inches in direction that sheds water. Fasten upper end of each length to roof deck beneath overlap.
 - 1. Secure hemmed flange edges into metal cleats and fastened to roof deck.
 - 2. Adhere minimum 9 inch wide strips of self-adhering sheet underlayment to metal flanges and to underlying self-adhering sheet underlayment.
 - a. Place strips parallel to and over flanges so that they will be just concealed by installed shingles.
 - 3. Provide a closure at end of the inverted-V profile of the valley metal to minimize water and ice infiltration.
- C. Rake Drip Edges: Install over underlayment materials and fasten to roof deck.
- D. Eave Drip Edges: Install below underlayment materials and fasten to roof deck.

- E. Pipe Flashings: Form flashing around pipe penetrations and asphalt shingles. Fasten and seal to asphalt shingles as recommended by manufacturer.

3.4 INSTALLATION OF ASPHALT SHINGLES

- A. Install asphalt shingles in accordance with manufacturer's written instructions and recommendations in ARMA's "Asphalt Roofing Residential Manual - Design and Application Methods" and NRCA's "NRCA Guidelines for Asphalt Shingle Roof Systems."
- B. Install starter strip along lowest roof edge, consisting of an asphalt shingle strip at least 7 inches wide with self-sealing strip face up at roof edge.
 - 1. Extend asphalt shingles 1/2 inch over fasciae at eaves and rakes.
 - 2. Install starter strip along rake edge.
- C. Install first and remaining courses of laminated asphalt shingles stair-stepping diagonally across roof deck with manufacturer's recommended offset pattern at succeeding courses, maintaining uniform exposure.
- D. Fasten asphalt shingle strips with number of nails indicated in manufacturer's written instructions for roof slope and design wind speed indicated on Drawings and for warranty requirements specified in this Section.
 - 1. Locate fasteners in accordance with manufacturer's written instructions.
 - 2. Where roof slope is less than 4:12, hand seal self-sealing asphalt shingles to improve shingles' positive bond by applying asphalt roofing cement spots between course overlaps after nailing upper course.
 - 3. When ambient temperature during installation is below 50 deg F, hand seal self-sealing asphalt shingles by applying asphalt roofing cement spots between course overlaps after nailing upper course.
- E. Open Valleys: Cut and fit asphalt shingles at open valleys, trimming upper concealed corners of shingle strips.
 - 1. Maintain uniform width of exposed open valley from highest to lowest point.
 - 2. Extend shingle a minimum of 4 inches over valley metal.
 - 3. Set valley edge of asphalt shingles in a 3 inch wide bed of asphalt roofing cement.
 - 4. Do not nail asphalt shingles to metal open-valley flashings.
- F. Ridge Vents: Install continuous ridge vents over asphalt shingles in accordance with manufacturer's written instructions. Fasten with roofing nails of sufficient length to penetrate sheathing.
- G. Hip and Ridge Shingles: Maintain same exposure of cap shingles as roofing-shingle exposure. Lap cap shingles at ridges to shed water away from direction of prevailing winds.
 - 1. Fasten with roofing nails of sufficient length to penetrate sheathing.
 - 2. Fasten ridge cap asphalt shingles to cover ridge vent without obstructing airflow.

END OF SECTION 073113

SECTION 074113.16
STANDING-SEAM METAL ROOF PANELS

PART 1 - GENERAL

1.1 SUMMARY

- A. Section Includes:
 - 1. Standing-seam metal roof panels.
- B. Related Requirements:
 - 1. Section 073013 – Roofing Underlayments.
 - 2. Section 074293 – Soffit Panels, for metal soffits.

1.2 ADMINISTRATIVE REQUIREMENTS

- A. Coordination:
 - 1. Coordinate sizes and locations of roof curbs, equipment supports, and roof penetrations with actual equipment provided.
 - 2. Coordinate metal panel installation with rain drainage Work, flashing, trim, construction of soffits, and other adjoining Work to provide a leakproof, secure, and noncorrosive installation.
- B. Preinstallation Meetings: Conduct meeting at Project site.
 - 1. Meet with Owner, Architect, Owner's insurer if applicable, metal panel Installer, metal panel manufacturer's representative, structural-support Installer, and installers whose Work interfaces with or affects metal panels, including installers of roof accessories and roof-mounted equipment.
 - 2. Review and finalize construction schedule and verify availability of materials, Installer's personnel, equipment, and facilities needed to make progress and avoid delays.
 - 3. Review methods and procedures related to metal panel installation, including manufacturer's written instructions.
 - 4. Examine support conditions for compliance with requirements, including alignment between and attachment to structural members.
 - 5. Review structural loading limitations of deck during and after roofing.
 - 6. Review flashings, special details, drainage, penetrations, equipment curbs, and condition of other construction that affect metal panels.
 - 7. Review governing regulations and requirements for insurance, certificates, and tests and inspections if applicable.
 - 8. Review temporary protection requirements for metal panel systems during and after installation.
 - 9. Review procedures for repair of metal panels damaged after installation.
 - 10. Document proceedings, including corrective measures and actions required, and furnish copy of record to each participant.

1.3 ACTION SUBMITTALS

- A. Product Data: For each type of product.
 - 1. Include construction details, material descriptions, dimensions of individual components and profiles, and finishes for each type of panel and accessory.
- B. Sustainable Design Submittals:
 - 1. Product Test Reports: For roof materials, documentation indicating that roof materials comply with Solar Reflectance Index requirements.
- C. Shop Drawings:

1. Include fabrication and installation layouts of metal panels; details of edge conditions, joints, panel profiles, corners, anchorages, attachment system, trim, flashings, closures, and accessories; and special details.
 2. Accessories: Include details of the flashing, trim, and anchorage systems, at a scale of not less than 1-1/2 inches per 12 inches.
- D. Samples for Verification: For each type of exposed finish required, prepared on Samples of size indicated below:
1. Metal Panels: 12 inches long by actual panel width. Include fasteners, closures, and other metal panel accessories.
- E. Delegated-Design Submittal: For standing-seam metal roof panel systems indicated to comply with performance requirements and design criteria, including analysis data signed and sealed by qualified professional engineer responsible for their preparation.
- 1.4 INFORMATIONAL SUBMITTALS
- A. Qualification Data: For Installer.
 - B. Product Test Reports: For each product, for tests performed by a qualified testing agency.
 - C. Sample Warranties: For special warranties.
- 1.5 CLOSEOUT SUBMITTALS
- A. Maintenance Data: For metal panels to include in maintenance manuals.
- 1.6 QUALITY ASSURANCE
- A. Manufacturer Qualifications: A firm that specializes in manufacturing of specified metal roofing systems with a minimum of 10 years of documented experience.
 - B. Installer Qualifications: An entity that employs installers and supervisors who are trained and approved by manufacturer with a minimum of 5 years of documented experience.
 - C. UL-Certified, Portable Roll-Forming Equipment: UL-certified, portable roll-forming equipment capable of producing metal panels warranted by manufacturer to be the same as factory-formed products. Maintain UL certification of portable roll-forming equipment for duration of Work.
 - D. Mockups: Build mockups to verify selections made under Sample submittals and to demonstrate aesthetic effects and set quality standards for fabrication and installation.
 1. Build mockup of typical roof area and eave, including fascia, **[and soffit]** as shown on Drawings; including attachments, underlayment, and accessories.
 - a. Mockup Size: 12 sq. ft. by full thickness.
 - b. Illustrate a complete assembly of each profile, proposed thickness, and finish.
 - c. Illustrate each type of exposed seam and seam termination.
 2. Approval of mockups does not constitute approval of deviations from Contract Documents contained in mockups unless Architect specifically approves such deviations in writing.
 3. Approved mockups may become part of completed Work if undisturbed at time of Substantial Completion.
- 1.7 DELIVERY, STORAGE, AND HANDLING
- A. Deliver components, metal panels, and other manufactured items so as not to be damaged or deformed. Package metal panels for protection during transportation and handling.
 - B. Unload, store, and erect metal panels in a manner to prevent bending, warping, twisting, and surface damage.

- C. Stack metal panels horizontally on platforms or pallets, covered with suitable weathertight and ventilated covering. Store metal panels to ensure dryness, with positive slope for drainage of water. Do not store metal panels in contact with other materials that might cause staining, denting, or other surface damage.
- D. Retain strippable protective covering on metal panels during installation.
- E. Copper Panels: Wear gloves when handling to prevent fingerprints and soiling of surface.

1.8 FIELD CONDITIONS

- A. Weather Limitations: Proceed with installation only when existing and forecasted weather conditions permit assembly of metal panels to be performed according to manufacturers' written instructions and warranty requirements.

1.9 WARRANTY

- A. Special Warranty: Manufacturer agrees to repair or replace components of metal panel systems that fail in materials or workmanship within specified warranty period.
 - 1. Failures include the following:
 - a. Structural failures including rupturing, cracking, or puncturing.
 - b. Deterioration of metals and other materials beyond normal weathering.
 - 2. Warranty Period: 2 years from date of Substantial Completion.
- B. Special Warranty on Panel Finishes: Manufacturer agrees to repair finish or replace metal panels that show evidence of deterioration of factory-applied finishes within specified warranty period.
 - 1. Exposed Panel Finish: Deterioration includes the following:
 - a. Color fading more than 5 Delta E units when tested according to ASTM D2244.
 - b. Chalking in excess of a No. 8 rating when tested according to ASTM D4214.
 - c. Cracking, checking, peeling, or failure of paint to adhere to bare metal.
 - 2. Finish Warranty Period: 10 **[20]** years from date of Substantial Completion.

PART 2 - PRODUCTS

2.1 MANUFACTURERS

- A. Source Limitations: Obtain standing-seam metal roof panels[,], **[formed metal roof panels]**[,], **[and metal wall panels]**[,], **[and metal soffit panels]** from single source from single manufacturer.

2.2 PERFORMANCE CRITERIA

- A. Recycled Content: Postconsumer recycled content plus 1/2 of preconsumer recycled content not less than 50 percent.
- B. Delegated Design: Engage a qualified professional engineer, as defined in Section 014000 – Quality Requirements, to design standing-seam metal roof panel systems, including attachment to building construction.
- C. Solar Reflectance Index (SRI): 3-year-aged SRI not less than **[64]** **[32]** or initial SRI not less than **[82]** **[39]** when calculated according to ASTM E1980, based on testing identical products by a qualified testing agency.
- D. Energy Performance: Provide roof panels that are listed on the EPA/DOE's ENERGY STAR "Roof Product List" for **[low]** steep-slope roof products.
- E. Energy Performance: Provide roof panels according to one of the following when tested according to CRRC-1:

1. 3-year, aged solar reflectance of not less than 0.55 and emissivity of not less than 0.75.
 2. 3-year, aged Solar Reflectance Index of not less than 64 when calculated according to ASTM E1980.
- F. Structural Performance: Provide metal panel systems capable of withstanding the effects of the following loads, based on testing according to ASTM E1592:
1. Wind Loads: As indicated on Drawings.
 2. Other Design Loads: As indicated on Drawings.
 3. Deflection Limits: For wind loads, no greater than 1/180 [**1/240**] of span.
- G. Seismic Performance: Exterior metal panel systems, including anchors and connections, shall withstand effects of earthquake motions determined according to ASCE 7.
1. Component Importance Factor: 1.0.
- H. Air Leakage: Air leakage of not more than 0.02 [**0.06**] cfm/sq. ft. when tested according to ASTM E1680 or ASTM E283 at the following test-pressure difference:
1. Test-Pressure Difference: Positive and negative 12 lbf/sq. ft. [**15 lbf/sq. ft.**] [**1.57 lbf/sq. ft.**] [**6.24 lbf/sq. ft.**]
- I. Water Penetration under Static Pressure: No water penetration when tested according to ASTM E1646 or ASTM E331 at the following test-pressure difference:
1. Test-Pressure Difference: 15 lbf/sq. ft. [**2.86 lbf/sq. ft.**] [**6.24 lbf/sq. ft.**].
- J. Wind-Uplift Resistance: Provide metal roof panel assemblies that comply with UL 580 for wind-uplift-resistance class indicated.
1. Uplift Rating: UL 90.
- K. **[FM Global Listing: Provide metal roof panels and component materials that comply with requirements in FM Global 4471 as part of a panel roofing system and that are listed in FM Global's "Approval Guide" for Class 1 or noncombustible construction, as applicable. Identify materials with FM Global markings.]**
1. **[Fire/Windstorm Classification: Class 1A-[60] [75] [90] [105] [120].**
 2. **[Hail Resistance: MH].**
- L. Thermal Movements: Allow for thermal movements from ambient and surface temperature changes by preventing buckling, opening of joints, overstressing of components, failure of joint sealants, failure of connections, and other detrimental effects. Base calculations on surface temperatures of materials due to both solar heat gain and nighttime-sky heat loss.
1. Temperature Change (Range): 120 deg F, ambient; 180 deg F, material surfaces.

2.3 STANDING-SEAM METAL ROOF PANELS

- A. Provide factory-formed metal roof panels designed to be installed by lapping and interconnecting raised side edges of adjacent panels with joint type indicated and mechanically attaching panels to supports using concealed clips in side laps. Include clips, cleats, pressure plates, and accessories required for weathertight installation.
1. Steel Panel Systems: Unless more stringent requirements are indicated, comply with ASTM E1514.
 2. **[Aluminum Panel Systems: Unless more stringent requirements are indicated, comply with ASTM E1637.]**
- B. Vertical-Rib, Snap-Joint, Standing-Seam Metal Roof Panels: Formed with vertical ribs at panel edges and a flat pan [**intermediate stiffening ribs symmetrically spaced**] between ribs; designed for sequential installation by mechanically attaching panels to supports using concealed clips located under 1 side of panels, engaging opposite edge of adjacent panels, and snapping panels together.
1. Basis-of-Design Product: Subject to compliance with requirements, provide **<Insert Product Name>** by **<Insert Manufacturer's Name>** or approved substitution from one of the following:

- a. AEP Span, a Division of ASC Profiles, Inc.: Design Span hp.
 - b. Berridge Manufacturing Company: Cee-Lock Panel.
 - c. MBCI, Inc. Product: BattenLok HS.
 - d. Firestone Building Products, LLC.
 - e. Innovative Metals Company, Inc. (IMETCO): TwinLok 1.5.
 - f. McElroy Metal, Inc.: Maxima 1.5" Panel
 - g. Metal Sales Manufacturing Corporation.
 - h. Peterson Aluminum Corporation.
 - i. Approved substitution.
2. Metallic-Coated Steel Sheet: Zinc-coated (galvanized) steel sheet complying with ASTM A653, G90 coating designation, structural quality. Prepainted by coil-coating process to comply with ASTM A755.
 - a. Nominal Thickness: 0.0232 inch.
 - b. Exterior Finish: 2-coat fluoropolymer.
 - c. Color: Selected by Architect from manufacturer's full range.
 3. Clips: 2-piece floating to accommodate thermal movement.
 - a. Material: 0.0250 inch thick, stainless-steel sheet or as required to meet performance requirements.
 4. Panel Coverage: 16 inches.
 5. Panel Height: 1.75 inches.
- C. Vertical-Rib, Snap-Joint, Standing-Seam Metal Roof Panels: Formed with vertical ribs at panel edges and a flat pan [**intermediate stiffening ribs symmetrically spaced**] between ribs; designed for sequential installation by mechanically attaching panels to supports using concealed clips located under one side of panels, engaging opposite edge of adjacent panels, and snapping panels together.
1. Basis-of-Design Product: Subject to compliance with requirements, provide **<Insert Product Name>** by **<Insert Manufacturer's Name>** or approved substitution from one of the following:
 - a. AEP Span, a Division of ASC Profiles, Inc..
 - b. ATAS International, Inc.
 - c. Berridge Manufacturing Company.
 - d. Firestone Building Products, LLC.
 - e. Innovative Metals Company, Inc. (IMETCO).
 - f. MBCI.
 - g. McElroy Metal, Inc.
 - h. Metal Sales Manufacturing Corporation.
 - i. Morin; a Kingspan Group Company.
 - j. NorthClad Rainscreen Solutions.
 - k. Petersen Aluminum Corp.
 - l. Approved substitution.
 2. Metallic-Coated Steel Sheet: Zinc-coated (galvanized) steel sheet complying with ASTM A653, G90 coating designation [**or aluminum-zinc alloy-coated steel sheet complying with ASTM A792, Class AZ50 coating designation**]; structural quality. Prepainted by the coil-coating process to comply with ASTM A755.
 - a. Nominal Thickness: [**0.022 inch**] [**0.028 inch**] [**0.034 inch**] [**0.040 inch**] [**0.052 inch**].
 - b. Exterior Finish: [**2-coat fluoropolymer**] [**3-coat fluoropolymer**] [**Mica fluoropolymer**] [**Metallic fluoropolymer**] [**FEVE fluoropolymer**] [**Siliconized polyester**].
 - c. Color: As selected by Architect from manufacturer's full range.
 3. Clips: 2-piece floating to accommodate thermal movement.
 - a. [**Material: 0.028 inch nominal thickness, zinc-coated (galvanized) or aluminum-zinc alloy-coated steel sheet.**]
 - b. Material: 0.0250 inch thick, stainless steel sheet.
 4. Panel Coverage: [**10 inches**] [**12 inches**] [**14 inches**] [**16 inches**] [**18 inches**] [**24 inches**].
 5. Panel Height: [**1.0 inch**] [**1.5 inches**] [**1.75 inches**].

- D. Vertical-Rib, Seamed-Joint, Standing-Seam Metal Roof Panels: Formed with vertical ribs at panel edges and a flat pan [**intermediate stiffening ribs symmetrically spaced**] between ribs; designed for sequential installation by mechanically attaching panels to supports using concealed clips located under 1 side of panels, engaging opposite edge of adjacent panels, and mechanically seaming panels together.
1. Basis-of-Design Product: Subject to compliance with requirements, provide <Insert Product Name> by <Insert Manufacturer's Name> or approved substitution from one of the following:
 - a. AEP Span, a Division of ASC Profiles, Inc.: [**Span-Lok hp**] [**SpanSeam**] Metal Roofing.
 - b. ATAS International, Inc.
 - c. Berridge Manufacturing Company.
 - d. Firestone Building Products, LLC.: UNA-CLAD UC-3.
 - e. Innovative Metals Company, Inc. (IMETCO).
 - f. MBCI.
 - g. McElroy Metal, Inc.
 - h. Metal Sales Manufacturing Corporation.
 - i. Morin; a Kingspan Group Company.
 - j. NorthClad Rainscreen Solutions.
 - k. Petersen Aluminum Corp.
 - l. Approved substitution.
 2. Metallic-Coated Steel Sheet: Zinc-coated (galvanized) steel sheet complying with ASTM A653, G90 coating designation. Prepainted by coil-coating process to comply with ASTM A755.
 - a. Nominal Thickness: 0.0250 inch.
 - b. Exterior Finish: 2-coat fluoropolymer.
 - c. Color: As selected by Architect from manufacturer's full range.
 3. Clips: Floating to accommodate thermal movement.
 - a. Material: 0.0250 inch thick, stainless-steel sheet or as required to meet performance requirements.
 4. Joint Type: Single folded.
 5. Panel Coverage: 16 inches.
 6. Panel/Seam Height: 2.0 inches.
- E. Vertical-Rib, Seamed-Joint, Standing-Seam Metal Roof Panels: Formed with vertical ribs at panel edges and a flat pan [**intermediate stiffening ribs symmetrically spaced**] between ribs; designed for sequential installation by mechanically attaching panels to supports using concealed clips located under one side of panels, engaging opposite edge of adjacent panels, and mechanically seaming panels together.
1. Basis-of-Design Product: Subject to compliance with requirements, provide <Insert Product Name> by <Insert Manufacturer's Name> or approved substitution from one of the following:
 - a. AEP Span, a Division of ASC Profiles, Inc..
 - b. ATAS International, Inc.
 - c. Berridge Manufacturing Company.
 - d. Firestone Building Products, LLC.
 - e. Innovative Metals Company, Inc. (IMETCO).
 - f. MBCI.
 - g. McElroy Metal, Inc.
 - h. Metal Sales Manufacturing Corporation.
 - i. Morin; a Kingspan Group Company.
 - j. NorthClad Rainscreen Solutions.
 - k. Petersen Aluminum Corp.
 - l. Approved substitution.
 2. Metallic-Coated Steel Sheet: Zinc-coated (galvanized) steel sheet complying with ASTM A653, G90 coating designation [**or aluminum-zinc alloy-coated steel sheet complying with ASTM A792, Class AZ50 coating designation**]; structural quality. Prepainted by the coil-coating process to comply with ASTM A755.

- a. Nominal Thickness: **[0.022 inch] [0.028 inch] [0.034 inch] [0.040 inch] [0.052 inch]**.
- b. Exterior Finish: **[2-coat fluoropolymer] [3-coat fluoropolymer] [Mica fluoropolymer] [Metallic fluoropolymer] [FEVE fluoropolymer] [Siliconized polyester]**.
- c. Color: As selected by Architect from manufacturer's full range.
3. Clips: 2-piece floating to accommodate thermal movement.
 - a. **[Material: 0.028 inch nominal thickness, zinc-coated (galvanized) or aluminum-zinc alloy-coated steel sheet.]**
 - b. Material: 0.0250 inch thick, stainless steel sheet.
4. Joint Type: **[Single folded] [Double folded] [As standard with manufacturer]**.
5. Panel Coverage: **[12 inches] [14 inches] [16 inches] [18 inches] [20 inches] [24 inches]**.
6. Panel Height: **[1.5 inches] [2.0 inches] [2.5 inches]**.

2.4 UNDERLAYMENT MATERIALS

- A. Roofing underlayment materials are specified in Section 073013 – Roofing Underlayments.

2.5 MISCELLANEOUS MATERIALS

- A. Miscellaneous Metal Subframing and Furring: ASTM C645; cold-formed, metallic-coated steel sheet, ASTM A653, G90 coating designation or ASTM A792, Class AZ50 coating designation unless otherwise indicated. Provide manufacturer's standard sections as required for support and alignment of metal panel system.
- B. Panel Accessories: Provide components required for a complete, weathertight panel system including trim, copings, fasciae, mullions, sills, corner units, clips, flashings, sealants, gaskets, fillers, closure strips, and similar items. Match material and finish of metal panels unless otherwise indicated.
 1. Closures: Provide closures at eaves and ridges, fabricated of same metal as metal panels.
 2. Backing Plates: Provide metal backing plates at panel end splices, fabricated from material recommended by manufacturer.
 3. Closure Strips: Closed-cell, expanded, cellular, rubber or crosslinked, polyolefin-foam or closed-cell laminated polyethylene; minimum 1 inch thick, flexible closure strips; cut or premolded to match metal panel profile. Provide closure strips where indicated or necessary to ensure weathertight construction.
- C. Flashing and Trim: Provide flashing and trim formed from same material as metal panels as required to seal against weather and to provide finished appearance. Locations include, but are not limited to, eaves, rakes, corners, bases, framed openings, ridges, fasciae, and fillers. Finish flashing and trim with same finish system as adjacent metal panels.
- D. Gutters: Formed from same material roof panels, complete with end pieces, outlet tubes, and other special pieces as required. Fabricate in minimum 96 inch long sections, of size and metal thickness according to SMACNA's "Architectural Sheet Metal Manual." Furnish gutter supports spaced a maximum of 36 inches on center, fabricated from same metal as gutters. Provide wire ball strainers of compatible metal at outlets. Finish gutters to match metal roof panels.
- E. Downspouts: Formed from same material as roof panels. Fabricate in 10 foot long sections, complete with formed elbows and offsets, of size and metal thickness according to SMACNA's "Architectural Sheet Metal Manual". Finish downspouts to match gutters.
- F. Roof Curbs: Fabricated from same material as roof panels, minimum 0.048 inch nominal thickness; with bottom of skirt profiled to match roof panel profiles, with welded top box and integral full-length cricket. Fabricate curb subframing of minimum 0.060 inch nominal thickness, angle-, C-, or Z-shaped steel sheet. Fabricate curb and subframing to withstand indicated loads, of size and height indicated. Finish roof curbs to match metal roof panels.
 1. Insulate roof curb with 1 inch thick, rigid insulation.

- G. Panel Fasteners: Self-tapping screws designed to withstand design loads.
- H. Panel Sealants: Provide sealant type recommended by manufacturer that are compatible with panel materials, are nonstaining, and do not damage panel finish.
 - 1. Sealant Tape: Pressure-sensitive, 100 percent solids, gray polyisobutylene compound sealant tape with release-paper backing; 1/2 inch wide and 1/8 inch thick.
 - 2. Joint Sealant: ASTM C920; as recommended in writing by metal roof panel manufacturer and complying with Section 079200.
 - 3. Butyl-Rubber-Based, Solvent-Release Sealant: ASTM C1311.
- I. **[Snow Guards: As specified in Section 077253.]**

2.6 FABRICATION

- A. Fabricate and finish metal panels and accessories at the factory, by manufacturer's standard procedures and processes, as necessary to fulfill indicated performance requirements demonstrated by laboratory testing. Comply with indicated profiles and with dimensional and structural requirements.
- B. On-Site Fabrication: Subject to compliance with requirements of this Section, metal panels may be fabricated on-site using UL-certified, portable roll-forming equipment if panels are of same profile and warranted by manufacturer to be equal to factory-formed panels. Fabricate according to equipment manufacturer's written instructions and to comply with details shown.
- C. Provide panel profile, including major ribs and intermediate stiffening ribs, if any, for full length of panel.
- D. Fabricate metal panel joints with factory-installed captive gaskets or separator strips that provide a weathertight seal and prevent metal-to-metal contact, and that minimize noise from movements.
- E. Sheet Metal Flashing and Trim: Fabricate flashing and trim to comply with manufacturer's recommendations and recommendations in SMACNA's "Architectural Sheet Metal Manual" that apply to design, dimensions, metal, and other characteristics of item indicated.
 - 1. Form exposed sheet metal accessories that are without excessive oil canning, buckling, and tool marks and that are true to line and levels indicated, with exposed edges folded back to form hems.
 - 2. **[Seams for Aluminum: Fabricate nonmoving seams with flat-lock seams. Form seams and seal with epoxy seam sealer. Rivet joints for additional strength.]**
 - 3. Seams for Other Than Aluminum: Fabricate nonmoving seams in accessories with flat-lock seams. Tin edges to be seamed, form seams, and solder.
 - 4. Sealed Joints: Form nonexpansion, but movable, joints in metal to accommodate sealant and to comply with SMACNA standards.
 - 5. Conceal fasteners and expansion provisions where possible. Exposed fasteners are not allowed on faces of accessories exposed to view.
 - 6. Fabricate cleats and attachment devices from same material as accessory being anchored or from compatible, noncorrosive metal recommended in writing by metal panel manufacturer.
 - a. Size: As recommended by SMACNA's "Architectural Sheet Metal Manual" or metal panel manufacturer for application, but not less than thickness of metal being secured.

2.7 FINISHES

- A. Protect mechanical and painted finishes on exposed surfaces from damage by applying a strippable, temporary protective covering before shipping.
- B. Appearance of Finished Work: Variations in appearance of abutting or adjacent pieces are acceptable if they are within 1/2 of range of approved Samples. Noticeable variations in same piece

are unacceptable. Variations in appearance of other components are acceptable if they are within range of approved Samples and are assembled or installed to minimize contrast.

C. Steel Panels and Accessories:

1. 2-Coat Fluoropolymer: AAMA 621. Fluoropolymer finish containing not less than 70 percent polyvinylidene fluoride (PVDF) resin by weight in color coat. Prepare, pretreat, and apply coating to exposed metal surfaces to comply with coating and resin manufacturers' written instructions.
2. 3-Coat Fluoropolymer: AAMA 621. Fluoropolymer finish containing not less than 70 percent polyvinylidene fluoride (PVDF) resin by weight in both color coat and clear topcoat. Prepare, pretreat, and apply coating to exposed metal surfaces to comply with coating and resin manufacturers' written instructions.
3. Mica Fluoropolymer: AAMA 621. 2-coat fluoropolymer finish with suspended mica flakes containing not less than 70 percent polyvinylidene fluoride (PVDF) resin by weight in color coat. Prepare, pretreat, and apply coating to exposed metal surfaces to comply with coating and resin manufacturers' written instructions.
4. FEVE Fluoropolymer: AAMA 621. 2-coat fluoropolymer finish containing 100 percent fluorinated ethylene vinyl ether resin (FEVE) in color coat. Prepare, pretreat, and apply coating to exposed metal surfaces to comply with coating and resin manufacturers' written instructions.
5. Siliconized Polyester: Epoxy primer and silicone-modified, polyester-enamel topcoat; with a dry film thickness of not less than 0.2 mil for primer and 0.8 mil for topcoat.
6. Concealed Finish: Apply pretreatment and manufacturer's standard white or light-colored acrylic or polyester backer finish consisting of prime coat and wash coat with a minimum total dry film thickness of 0.5 mil.

D. Aluminum Panels and Accessories:

1. 2-Coat Fluoropolymer: AAMA 2605. Fluoropolymer finish containing not less than 70 percent polyvinylidene fluoride (PVDF) resin by weight in color coat. Prepare, pretreat, and apply coating to exposed metal surfaces to comply with coating and resin manufacturers' written instructions.
2. 3-Coat Fluoropolymer: AAMA 2605. Fluoropolymer finish containing not less than 70 percent polyvinylidene fluoride (PVDF) resin by weight in both color coat and clear topcoat. Prepare, pretreat, and apply coating to exposed metal surfaces to comply with coating and resin manufacturers' written instructions.
3. Mica Fluoropolymer: AAMA 2605. 2-coat fluoropolymer finish with suspended mica flakes containing not less than 70 percent polyvinylidene fluoride (PVDF) resin by weight in color coat. Prepare, pretreat, and apply coating to exposed metal surfaces to comply with coating and resin manufacturers' written instructions.
4. Metallic Fluoropolymer: AAMA 2605. 3-coat fluoropolymer finish with suspended metallic flakes containing not less than 70 percent polyvinylidene fluoride (PVDF) resin by weight in both color coat and clear topcoat. Prepare, pretreat, and apply coating to exposed metal surfaces to comply with coating and resin manufacturers' written instructions.
5. FEVE Fluoropolymer: AAMA 2605. 2-coat fluoropolymer finish containing 100 percent fluorinated ethylene vinyl ether (FEVE) resin in color coat. Prepare, pretreat, and apply coating to exposed metal surfaces to comply with coating and resin manufacturers' written instructions.
6. Siliconized Polyester: Epoxy primer and silicone-modified, polyester-enamel topcoat; with a dry film thickness of not less than 0.2 mil for primer and 0.8 mil for topcoat.
7. Exposed Anodized Finish:
 - a. Clear Anodic Finish: AAMA 611, AA-M12C22A41, Class I, 0.018 mm or thicker.
 - b. Color Anodic Finish: AAMA 611, AA-M12C22A42/A44, Class I, 0.018 mm or thicker.
 - 1) Color: [Light bronze] [Medium bronze] [Dark bronze] [Black].

E. [Stainless Steel Panels and Accessories:]

1. Surface Preparation: Remove tool and die marks and stretch lines, or blend into finish.

2. Polished Finishes: Grind and polish surfaces to produce uniform finish, free of cross scratches.
 - a. Run grain of directional finishes with long dimension of each piece.
 - b. When polishing is completed, passivate and rinse surfaces. Remove embedded foreign matter and leave surfaces chemically clean.
 - c. Directional Satin Finish: ASTM A480 No. 4.

PART 3 - EXECUTION

3.1 EXAMINATION

- A. Examine substrates, areas, and conditions, with Installer present, for compliance with requirements for installation tolerances, metal panel supports, and other conditions affecting performance of Work.
 1. Examine primary and secondary roof framing to verify that rafters, purlins, angles, channels, and other structural panel support members and anchorages have been installed within alignment tolerances required by metal roof panel manufacturer.
 2. Examine solid roof sheathing to verify that sheathing joints are supported by framing or blocking and that installation is within flatness tolerances required by metal roof panel manufacturer.
 - a. Verify that air- or water-resistive barriers have been installed over sheathing or backing substrate to prevent air infiltration or water penetration.
- B. Examine roughing-in for components and systems penetrating metal panels to verify actual locations of penetrations relative to seam locations of metal panels before installation.
- C. Proceed with installation only after unsatisfactory conditions have been corrected.

3.2 PREPARATION

- A. Miscellaneous Supports: Install subframing, furring, and other miscellaneous panel support members and anchorages according to ASTM C754 and metal panel manufacturer's written recommendations.

3.3 INSTALLATION OF UNDERLAYMENT

- A. Underlayments: Install underlayment materials to comply with requirements specified in Section 073013 – Roofing Underlayments.
- B. Flashings: Install flashings to cover underlayment to comply with requirements specified in Section 076200 – Sheet Metal Flashing and Trim.

3.4 INSTALLATION OF STANDING SEAM METAL ROOF PANELS

- A. Install metal panels according to manufacturer's written instructions in orientation, sizes, and locations indicated. Install panels perpendicular to supports unless otherwise indicated. Anchor metal panels and other components of Work securely in place, with provisions for thermal and structural movement.
 1. Shim or otherwise plumb substrates receiving metal panels.
 2. Flash and seal metal panels at perimeter of all openings. Fasten with self-tapping screws. Do not begin installation until air- or water-resistive barriers and flashings that will be concealed by metal panels are installed.
 3. Install screw fasteners in predrilled holes.
 4. Locate and space fastenings in uniform vertical and horizontal alignment.
 5. Install flashing and trim as metal panel Work proceeds.
 6. Locate panel splices over, but not attached to, structural supports. Stagger panel splices and end laps to avoid a four-panel lap splice condition.
 7. Align bottoms of metal panels and fasten with blind rivets, bolts, or self-tapping screws. Fasten flashings and trim around openings and similar elements with self-tapping screws.

8. Provide weathertight escutcheons for pipe- and conduit-penetrating panels.
- B. Fasteners:
 1. Steel Panels: Use stainless steel fasteners for surfaces exposed to exterior; use galvanized-steel fasteners for surfaces exposed to interior.
 2. **[Aluminum Panels: Use aluminum or stainless steel fasteners for surfaces exposed to exterior; use aluminum or galvanized-steel fasteners for surfaces exposed to interior.]**
 3. **[Stainless Steel Panels: Use stainless steel fasteners.]**
- C. Anchor Clips: Anchor metal roof panels and other components of Work securely in place, using manufacturer's approved fasteners according to manufacturers' written instructions.
- D. Metal Protection: Where dissimilar metals contact each other or corrosive substrates, protect against galvanic action as recommended in writing by metal panel manufacturer.
- E. Standing-Seam Metal Roof Panel Installation: Fasten metal roof panels to supports with concealed clips at each standing-seam joint at location, spacing, and with fasteners recommended in writing by manufacturer.
 1. Install clips to supports with self-tapping fasteners.
 2. Install pressure plates at locations indicated in manufacturer's written installation instructions.
 3. Snap Joint: Nest standing seams and fasten together by interlocking and completely engaging factory-applied sealant.
 4. Seamed Joint: Crimp standing seams with manufacturer-approved, motorized seamer tool so clip, metal roof panel, and factory-applied sealant are completely engaged.
 5. Watertight Installation:
 - a. Apply a continuous ribbon of sealant or tape to seal joints of metal panels, using sealant or tape as recommend in writing by manufacturer as needed to make panels watertight.
 - b. Provide sealant or tape between panels and protruding equipment, vents, and accessories.
 - c. At panel splices, nest panels with minimum 6 inch end lap, sealed with sealant and fastened together by interlocking clamping plates.
- F. Accessory Installation: Install accessories with positive anchorage to building and weathertight mounting, and provide for thermal expansion. Coordinate installation with flashings and other components.
 1. Install components required for a complete metal panel system including trim, copings, corners, seam covers, flashings, sealants, gaskets, fillers, closure strips, and similar items. Provide types indicated by metal roof panel manufacturers; or, if not indicated, types recommended by metal roof panel manufacturer.
- G. Flashing and Trim: Comply with performance requirements, manufacturer's written installation instructions, and SMACNA's "Architectural Sheet Metal Manual." Provide concealed fasteners where possible, and set units true to line and level as indicated. Install Work with laps, joints, and seams that will be permanently watertight and weather resistant.
 1. Install exposed flashing and trim that is without buckling and tool marks, and that is true to line and levels indicated, with exposed edges folded back to form hems. Install sheet metal flashing and trim to fit substrates and achieve waterproof and weather-resistant performance.
 2. Expansion Provisions: Provide for thermal expansion of exposed flashing and trim. Space movement joints at a maximum of 10 feet with no joints allowed within 24 inches of corner or intersection. Where lapped expansion provisions cannot be used or would not be sufficiently weather resistant and waterproof, form expansion joints of intermeshing hooked flanges, not less than 1 inch deep, filled with mastic sealant (concealed within joints).
- H. Gutters: Join sections with riveted and soldered or lapped and sealed joints. Attach gutters to eave with gutter hangers spaced not more than 36 inches on center using manufacturer's standard fasteners. Provide end closures and seal watertight with sealant. Provide for thermal expansion.

- I. Downspouts: Join sections with telescoping joints. Provide fasteners designed to hold downspouts securely 1 inch away from walls; locate fasteners at top and bottom and at approximately 60 inches on center in between.
 - 1. Provide elbows at base of downspouts to direct water away from building.
 - 2. Connect downspouts to underground drainage system indicated.
- J. Roof Curbs: Install flashing around bases where they meet metal roof panels.
- K. Pipe Flashing: Form flashing around pipe penetration and metal roof panels. Fasten and seal to metal roof panels as recommended by manufacturer.
- L. **[Snow Guard Installation: As specified in Section 077253.]**

3.5 ERECTION TOLERANCES

- A. Installation Tolerances: Shim and align metal panel units within installed tolerance of 1/4 inch in 20 feet on slope and location lines as indicated and within 1/8 inch offset of adjoining faces and of alignment of matching profiles.

3.6 FIELD QUALITY CONTROL

- A. Manufacturer's Field Service: Engage a factory-authorized service representative to test and inspect metal roof panel installation, including accessories. Report results in writing.
- B. Remove and replace applications of metal roof panels where tests and inspections indicate that they do not comply with specified requirements.
- C. Additional tests and inspections, at Contractor's expense, are performed to determine compliance of replaced or additional Work with specified requirements.
- D. Prepare test and inspection reports.

3.7 CLEANING AND PROTECTION

- A. Remove temporary protective coverings and strippable films, if any, as metal panels are installed, unless otherwise indicated in manufacturer's written installation instructions. On completion of metal panel installation, clean finished surfaces as recommended by metal panel manufacturer. Maintain in a clean condition during construction.
- B. Replace metal panels that have been damaged or have deteriorated beyond successful repair by finish touchup or similar minor repair procedures.

END OF SECTION 074113.16

SECTION 074646
FIBER-CEMENT SIDING

PART 1 - GENERAL

1.1 SUMMARY

- A. Section Includes
 - 1. Fiber-cement siding and soffits.
 - 2. Vented, horizontal drainage furring.

1.2 ADMINISTRATIVE REQUIREMENTS

- A. Coordination:
 - 1. Coordinate siding installation with flashings and other adjoining construction to ensure proper sequencing.
- B. Preinstallation Meetings: Conduct Meeting at Project site.

1.3 ACTION SUBMITTALS

- A. Product Data: For each type of product.
- B. Shop Drawings:
 - 1. Provide detailed drawings of atypical, non-standard applications of cementitious siding materials which are outside scope of standard details and specifications provided by manufacturer.
- C. Samples for Verification:
 - 1. 12 inch long by actual width Samples of:
 - a. Each type of siding.
 - b. Soffit.
 - c. Trim and accessories.

1.4 INFORMATIONAL SUBMITTALS

- A. Product Certificates: For each type of fiber-cement siding, soffit, and drainage furring.
- B. Sealant Certification: From fiber-cement manufacturer indicating acceptance of proposed joint sealant.
- C. Product Test Reports: Based on evaluation of comprehensive tests performed by a qualified testing agency, for fiber-cement siding.
- D. Research/Evaluation Reports: For each type of fiber-cement siding required, from ICC-ES.

1.5 CLOSEOUT SUBMITTALS

- A. Maintenance Data: For each type of product, including drainage furring and related accessories, to include in maintenance manuals.

1.6 MAINTENANCE MATERIAL SUBMITTALS

- A. Furnish extra materials that match products installed and that are packaged with protective covering for storage and identified with labels describing contents.
 - 1. Furnish full lengths of fiber-cement siding and soffit, including drainage furring and related accessories, in a quantity equal to 2 percent of amount installed.

1.7 QUALITY ASSURANCE

- A. Installer Qualifications: An entity specializing in performing type of work specified and approved by manufacturer with a minimum of 3 years of documented experience.
- B. Mockups: Build mockups to verify selections made under Sample submittals and to demonstrate aesthetic effects and to set quality standards for fabrication and installation.
 - 1. Build mockup of typical wall area as shown on Drawings.
 - 2. Build mockups for fiber-cement siding and soffit, including drainage furring and related accessories.
 - a. Size: 48 inches long by 60 inches high.
 - b. Include outside corner on one end of mockup and inside corner on other end.
 - 3. Approval of mockups does not constitute approval of deviations from Contract Documents contained in mockups unless Architect specifically approves such deviations in writing.
 - 4. Subject to compliance with requirements, approved mockups may become part of completed Work if undisturbed at time of Substantial Completion.

1.8 DELIVERY, STORAGE, AND HANDLING

- A. Deliver and store packaged materials in original containers with labels intact until time of use.
- B. Store materials on elevated platforms, under cover, and in a dry location.

1.9 WARRANTY

- A. Special Warranty: Manufacturer agrees to repair or replace products that fail in materials or workmanship within specified warranty period.
 - 1. Failures include the following:
 - a. Structural failures including cracking and deforming.
 - b. Deterioration of materials beyond normal weathering.
 - 2. Warranty Period: 30 years from date of Substantial Completion.
- B. Special Warranty on Panel Finishes: Manufacturer agrees to repair finish or replace fiber-cement panels that show evidence of deterioration of factory-applied finishes within specified warranty period. Deterioration includes the following:
 - 1. Cracking, checking, peeling, or failure of paint to adhere to bare metal.
 - 2. Finish Warranty Period: Minimum 15 years from date of Substantial Completion.

PART 2 - PRODUCTS

2.1 MANUFACTURERS

- A. Manufacturers: Subject to compliance with requirements, provide products by one of the following:
 - 1. American Fiber Cement Corp.
 - 2. Elementia.
 - 3. James Hardie Building Products, Inc.
 - 4. Nichiha USA, Inc.
 - 5. Swisspearl.
 - 6. Approved substitution.

- B. Source Limitations: Obtain products, including related accessories, from single source from single manufacturer.

2.2 FIBER-CEMENT PRODUCTS, GENERAL

- A. Type A, Grade II, fiber-cement conforming to ASTM C1186; noncombustible when tested according to ASTM E136.
 - 1. Surface Burning Characteristics: Class A according to ASTM E84:
 - a. Flame Spread: 25.
 - b. Smoke Developed: 0.
 - 2. Factory primed with manufacturer's standard acrylic primer.

2.3 FIBER-CEMENT SIDING

- A. Siding Type-1: Panel siding complying with the following:
 - 1. Thickness: Not less than 5/16 inch.
 - 2. Width: 48 inches.
 - 3. Length: 120 inches.
 - 4. Surface: Smooth.
 - 5. Exposed Coverage: 40 sq. ft.
 - 6. Edges: Square or tongue and groove, 4 edges.
 - a. Edge Sealant: Joint sealant factory-applied to 1 end and 1 side edge.
- B. Siding Type-2: Lap siding with a sloped top, beveled drip edge, and nailing line.
 - 1. Thickness: Not less than 5/16 inch.
 - 2. Width: Nominal 12 inch wide with 10-3/4 inch exposure.
 - 3. Length: 144 inches.
 - 4. Surface: Smooth.
 - 5. Edges: Ship-lapped on long edges.
 - a. Edge Sealant: Joint sealant factory-applied to 1 end and 1 side edge.

2.4 FIBER-CEMENT TRIM

- A. Manufacturer's trim units from same collection as siding and complying with the following:
 - 1. Type: Batten.
 - 2. Thickness: Not less than 1 inch.
 - 3. Width: 2.5 and 5.5 inches where indicated on Drawings.
 - 4. Length: 144 inches.
 - 5. Surface: Smooth Textured.
 - 6. Edges: Square 4 edges.
 - a. Edge Sealant: Joint sealant factory-applied to 1 end and 1 side edge.

2.5 ACCESSORIES

- A. Siding Accessories, General: Provide starter strips, edge trim, outside and inside corner caps, and other items as recommended or provided by fiber-cement panel manufacturer for Project configuration.
 - 1. Provide accessories matching color and texture of adjacent siding unless otherwise indicated.
- B. Hat-Shaped, Drainage Furring Channels: ASTM C955; steel furring channels with dimpled face and punched sides to minimize effects of hydrostatic pressure and allow ventilation behind siding system.
 - 1. Material: 0.0451 inch thick galvanized structural steel, Grade 33, with G90 coating.
 - 2. Minimum Base-Metal Thickness:
 - 3. Depth: 3/4 inch.
 - 4. Width: 4-3/4 inches overall with 3 inch wide face and 3/4 inch wide legs.

- C. Closures Components: Premanufactured products complying with the following:
 - 1. Material: 0.015 inch thick aluminum.
 - 2. Sizes:
 - a. Corners: As indicated.
 - b. Junction Flashing: 6 inches wide for 3 inch coverage on each side of butt joints.
 - 3. Surface: Smooth.
 - 4. Finish: Manufacturer's standard primer on exposed surfaces and epoxy coating on concealed surfaces.
- D. Flashing: Provide stainless-steel flashing complying with Section 076200 – Sheet Metal Flashing and Trim at window and door heads and where indicated.
- E. Fasteners:
 - 1. For fastening to metal, use ribbed bugle-head screws of sufficient length to penetrate a minimum of 1/4 inch, or 3 screw-threads, into substrate.
 - 2. For fastening to wood, use siding nails or ribbed bugle-head screws of sufficient length to penetrate a minimum of 1 inch into substrate.
- F. Continuous Soffit Vents: Aluminum, hat-channel shape, with perforations; 2 inches wide and not less than 96 inches long.
 - 1. Net-Free Area: Minimum of 6 sq. in./linear ft.
 - 2. Finish: Mill finish unless indicated otherwise.
- G. Insect Screening for Soffit Vents: Stainless steel, 18 by 18 mesh.
- H. Paint: As specified in Section 099000 –Painting and Coating, and acceptable to fiber-cement siding manufacturer.
 - 1. Provide primer acceptable to fiber-cement panel manufacturer if panels are not shop-primed.
- I. Sealant: Minimum ASTM C920, Type S, Grade NS, Class 35, urethane or silicone that provides 2 sided adhesion; acceptable to fiber-cement manufacturer.

PART 3 - EXECUTION

3.1 EXAMINATION

- A. Examine substrates for compliance with requirements for installation tolerances and other conditions affecting performance of fiber-cement siding and soffit and related accessories.
- B. Verify that weather or air barrier has been installed over substrate completely and correctly, and is ready to receive Work of this Section.
- C. Verify that flashing is installed above door and window trim and casings, above horizontal trim between panels, and where else indicated.
- D. Proceed with installation only after unsatisfactory conditions have been corrected.

3.2 PREPARATION

- A. Clean substrates of projections and substances detrimental to application.

3.3 INSTALLATION

- A. General: Comply with manufacturer's written installation instructions applicable to products and applications indicated unless more stringent requirements apply.
 - 1. Do not install damaged components.
 - 2. Install fasteners no more than 16 inches on center.

3. Clean cut and exposed panel edges and apply primer sealer or latex paint acceptable to fiber-cement panel manufacturer.
 4. Install joint sealants to produce a weathertight installation.
- B. Vertical Butt Joints:
1. Install fiber-cement panels with maximum 1/8 inch vertical butt joints and 1/4 inch horizontal butt joints, or as recommended by fiber cement siding manufacturer.
 2. Align vertical butt joints over center of girt or furring members. Vertical butt joints not installed this way will be unacceptable.
 3. Space vertical butt joints occurring in adjacent planks a minimum of 32 inches apart to avoid stair-step pattern of vertical butt joints.
 4. Locate vertical butt joints a minimum of 16 inches away from standing trim at window and door openings.
- C. Roof Edge Flashing:
1. Where vertical surfaces of fiber-cement panels meet roof edge flashing, provide 2 inch clearance between flashing and edge of fiber-cement panels, or as recommended by fiber cement siding manufacturer.
- D. Tolerances:
1. Maximum Variation of Siding Courses: Plumb, level, and out of plane within 1/4 inch tolerance in 10 foot.
 2. Maximum Offset Joint Alignment: 1/16 inch.
- 3.4 ADJUSTING
- A. Remove damaged, improperly installed, or otherwise defective materials and replace with new materials complying with specified requirements.
- 3.5 CLEANING
- A. Clean finished surfaces according to manufacturer's written instructions and maintain in a clean condition during construction.
- B. Where required by Federal, state, or local jurisdictions, provide acceptable means of containing and disposing of dust and debris created by handling, cutting, and installing of fiber-cement panels.

END OF SECTION 074646

SECTION 075423

THERMOPLASTIC-POLYOLEFIN (TPO) ROOFING

PART 1 - GENERAL

1.1 SUMMARY

- A. Section Includes:
1. Adhered thermoplastic polyolefin (TPO) roofing system.
 2. Cover boards.
 3. Vapor retarder.
 4. Roof insulation.

1.2 ADMINISTRATIVE REQUIREMENTS

- A. Preliminary Roofing Meeting: Before starting roof deck construction, conduct meeting at Project site.
1. Meet with Owner, Architect, Owner's insurer if applicable, testing and inspecting agency representative, roofing installer, roofing system manufacturer's representative, deck installer, and installers whose Work interfaces with or affects roofing, including installers of roof accessories and roof-mounted equipment.
 2. Review methods and procedures related to roofing installation, including manufacturer's written instructions.
 3. Review and finalize construction schedule and verify availability of materials, installer's personnel, equipment, and facilities needed to make progress and avoid delays.
 4. Review deck substrate requirements for conditions and finishes, including flatness and fastening.
 5. Review structural loading limitations of roof deck during and after roofing.
 6. Review base flashings, special roofing details, roof drainage, roof penetrations, equipment curbs, and condition of other construction that will affect roofing system.
 7. Review governing regulations and requirements for insurance and certificates if applicable.
 8. Review temporary protection requirements for roofing system during and after installation.
 9. Review roof observation and repair procedures after roofing installation.
- B. Preinstallation Roofing Meeting: Conduct meeting at Project site.
1. Meet with Owner, Architect, Owner's insurer if applicable, testing and inspecting agency representative, roofing Installer, roofing system manufacturer's representative, deck Installer, and installers whose work interfaces with or affects roofing, including installers of roof accessories and roof-mounted equipment.
 2. Review methods and procedures related to roofing installation, including manufacturer's written instructions.
 3. Review and finalize construction schedule and verify availability of materials, Installer's personnel, equipment, and facilities needed to make progress and avoid delays.
 4. Examine deck substrate conditions and finishes for compliance with requirements, including flatness and fastening.
 5. Review structural loading limitations of roof deck during and after roofing.
 6. Review base flashings, special roofing details, roof drainage, roof penetrations, equipment curbs, and condition of other construction that will affect roofing system.
 7. Review governing regulations and requirements for insurance and certificates if applicable.
 8. Review temporary protection requirements for roofing system during and after installation.
 9. Review roof observation and repair procedures after roofing installation.

1.3 ACTION SUBMITTALS

- A. Product Data: For each type of product.
 - 1. For insulation and roof system component fasteners, include copy of SPRI's Directory of Roof Assemblies listing.
- B. Sustainable Design Submittals:
 - 1. Environmental Product Declaration (EPD): For each product.
 - 2. Health Product Declaration (HPD): For each product.
 - 3. Product Test Reports: For roof materials, documentation indicating that roof materials comply with Solar Reflectance Index requirements.
 - 4. Product Data: F or adhesives and sealants, indicating VOC content.
 - 5. Laboratory Test Reports: For adhesives and sealants, indicating compliance with requirements for low-emitting materials.
 - 6. Product Data: For recycled content, indicating postconsumer and preconsumer recycled content and cost.
 - 7. Sourcing of Raw Materials: Corporate sustainability report for each manufacturer.
- C. Shop Drawings: Include roof plans, sections, details, and attachments to other Work, including the following:
 - 1. Layout and thickness of insulation.
 - 2. Base flashings and membrane terminations.
 - 3. Flashing details at penetrations.
 - 4. Tapered insulation, including slopes.
 - 5. Insulation fastening patterns for corner, perimeter, and field-of-roof locations.
 - 6. Tie-in with air barrier.
- D. Samples for Verification: Roof membrane and flashings, of color required.
- E. Wind Uplift Resistance Submittal: For roofing system, indicating compliance with wind uplift performance requirements.

1.4 INFORMATIONAL SUBMITTALS

- A. Qualification Data: For Installer and manufacturer certifying that Installer complies with requirements indicated in Quality Assurance Article.
 - 1. Installer's Qualification Data: Within 7 days of Notice to Proceed, submit name and qualification data for roofing Installer and membrane manufacturer indicating full compliance with Specification requirements. Architect and Owner reserve the right to reject roof Installer, membrane manufacturer, or both if documentation of full compliance with Specifications is not provided within allotted time period. In addition, submit certifications that verify Installer complies with requirements indicated in Quality Assurance Article.
- B. Manufacturer Certificates:
 - 1. Performance Requirement Certificate: Signed by roof membrane manufacturer, certifying that roofing system complies with requirements specified in "Performance Criteria" Article.
 - a. Submit evidence of compliance with performance criteria.
 - 2. Special Warranty Certificate: Signed by roof membrane manufacturer, certifying that materials supplied under this Section are acceptable for special warranty.
- C. Product Test Reports: For roof membrane and insulation, for tests performed by a qualified testing agency, indicating compliance with specified requirements.
- D. Evaluation Reports: For components of roofing system, from ICC-ES.
 - 1. Fastener-pullout test results and manufacturer's revised requirements for fastener patterns.
- E. Sample Warranties: For manufacturer's special warranties.

1.5 CLOSEOUT SUBMITTALS

- A. Maintenance Data: For roofing system to include in maintenance manuals.

1.6 QUALITY ASSURANCE

- A. Manufacturer Qualifications: A qualified manufacturer that specializes in manufacturing of specified roof membrane products, and is UL listed for roofing system identical to that specified for this Project, with a minimum of 10 years of documented experience.
- B. Installer Qualifications: Qualified firm that is approved, authorized, or licensed by roofing system manufacturer to install manufacturer's products and that is eligible to receive manufacturer's special warranty, with a minimum of 5 years of documented experience. In addition, qualified firm shall meet the following requirements:
 - 1. Specializes in type of roofing system work as this Project, and has been in business under same name and ownership for a minimum of 5 years.
- C. Roofing Superintendent: Qualified individual that is approved, authorized, or licensed by roofing system manufacturer to install manufacturer's products, with a minimum of 4 successful projects installing specified roof system.
 - 1. Superintendent shall remain on Project site for duration of roofing portions of Project.

1.7 DELIVERY, STORAGE, AND HANDLING

- A. Deliver roofing materials to Project site in original containers with seals unbroken and labeled with manufacturer's name, product brand name and type, date of manufacture, approval or listing agency markings, and directions for storing and mixing with other components.
- B. Store liquid materials in their original undamaged containers in a clean, dry, protected location and within the temperature range required by roofing system manufacturer. Protect stored liquid material from direct sunlight.
 - 1. Discard and legally dispose of liquid material that cannot be applied within its stated shelf life.
- C. Protect roof insulation materials from physical damage and from deterioration by sunlight, moisture, soiling, and other sources. Store in a dry location. Comply with insulation manufacturer's written instructions for handling, storing, and protecting during installation.
- D. Handle and store roofing materials and place equipment in a manner to avoid permanent deflection of deck.

1.8 FIELD CONDITIONS

- A. Weather Limitations: Proceed with installation only when existing and forecasted weather conditions permit roofing system to be installed according to manufacturer's written instructions and warranty requirements.

1.9 WARRANTY

- A. Special Project Warranty: Manufacturer's Total System Warranty, on form acceptable to Architect and Owner covering Work of this Section, signed by manufacturer, including components of roofing system indicated as follows:
 - 1. Materials as manufactured or authorized by roofing system manufacturer including vapor barrier, roof membrane, flashings, counterflashings, adhesives and sealants, insulation, cover boards, fasteners, fastener plates, fastening bars, metal Work, insulation adhesives, and other products utilized in this installation.
 - 2. Warranty Period: 20 years from date of Substantial Completion.

- B. Special Project Warranty: Submit roofing Installer's warranty, on form acceptable to Architect and Owner, covering Work of this Section, signed by Installer, warranting watertightness for system including at flashing, terminations, and penetrations for the following warranty period:
 - 1. Warranty Period: 2 years from date of Substantial Completion.

PART 2 - PRODUCTS

2.1 MANUFACTURERS

- A. Source Limitations: Obtain components for roofing system from manufacturers approved by or furnished by or roof membrane manufacturer.

2.2 PERFORMANCE CRITERIA

- A. General Performance: Installed roofing and base flashings shall withstand specified uplift pressures, thermally induced movement, and exposure to weather without failure due to defective manufacture, fabrication, installation, or other defects in construction. Roofing and base flashings shall remain watertight.
 - 1. Accelerated Weathering: Roof membrane shall withstand 2,000 hours of exposure when tested according to ASTM G152, ASTM G154, or ASTM G155.
 - 2. Impact Resistance: Roof membrane shall resist impact damage when tested according to ASTM D3746, ASTM D4272, or the "Resistance to Foot Traffic Test" in FM Approvals 4470.
- B. Material Compatibility: Roofing materials shall be compatible with one another and adjacent materials under conditions of service and application required, as demonstrated by roof membrane manufacturer based on testing and field experience.
- C. Wind Uplift Resistance: Design roofing system to resist wind uplift pressures indicated on Drawings when tested according to UL 580 or UL 1897.
- D. Solar Reflectance Index (SRI): 3 year aged SRI not less than 64 or initial SRI not less than 82 when calculated according to ASTM E1980, based on testing identical products by a qualified testing agency.
- E. ENERGY STAR Listing: Roofing system shall be listed on the DOE's ENERGY STAR "Roof Products Qualified Product List" for low-slope roof products.
- F. Fire-Resistance Ratings: Comply with fire-resistance-rated assembly designs indicated. Identify products with appropriate markings of applicable testing agency.

2.3 THERMOPLASTIC POLYOLEFIN (TPO) ROOFING

- A. TPO Sheet: ASTM D6878, internally fabric- or scrim-reinforced, fleece-backed TPO sheet.
 - 1. Products: Subject to compliance with requirements, provide products by one of the following:
 - a. Carlisle SynTec Incorporated: Sure-Weld TPO FleeceBACK 115-mil.
 - b. Firestone Building Products: UltraPly TPO XR 115.
 - c. Johns Manville: JM TPO FB 150.
 - d. Versico Incorporated: 115-mil VersiFleece TPO Membrane.
 - e. Approved substitution.
 - 2. Thickness: 115 mils, nominal.
 - 3. Weight of Fleece Backing: Minimum 8 oz/sq. yd.
 - 4. Exposed Face Color: White.

2.4 AUXILIARY ROOFING MATERIALS

- A. General: Auxiliary materials recommended by roofing system manufacturer for intended use and compatible with other roofing components.
 - 1. Provide adhesives and sealants as recommended or furnished by roofing manufacturer.
 - 2. Verify adhesives and sealants comply with VOC limits of authorities having jurisdiction.
 - 3. Verify adhesives and sealants comply with testing and product requirements of California Department of Public Health's "Standard Method for the Testing and Evaluation of Volatile Organic Chemical Emissions from Indoor Sources Using Environmental Chambers."
- B. Roof Edge Flashing: Roofing membrane manufacturer's TPO-coated sheet metal capable of being formed into a variety of shapes and profiles and heat-weldable to TPO roofing membrane.
 - 1. Steel Sheet: 0.028 inch thick zinc-coated (galvanized) steel sheet according to ASTM A653, G90 coating designation.
 - 2. Coating: 0.035 inch thick, non-reinforced TPO flashing laminated to exposed surface of steel sheet.
- C. Sheet Flashing: Manufacturer's standard sheet flashing, minimum 55 mils thick, of same color as TPO sheet.
- D. Prefabricated Pipe Flashings: As recommended by roof membrane manufacturer.
- E. Roof Vents: As recommended by roof membrane manufacturer.
 - 1. Size: Not less than 4 inch diameter.
- F. Bonding Adhesive: Manufacturer's standard low VOC, water-based adhesive.
- G. Metal Termination Bars: Manufacturer's standard stainless-steel or aluminum bars, pre-drilled at 6 inches on center, installed with noncorrosive fasteners.
 - 1. Size: Minimum 1/8 inch thick by 1 inch wide.
- H. Fasteners: Factory-coated steel fasteners and metal or plastic plates complying with corrosion-resistance, designed for fastening roofing components to substrate, and acceptable to roofing system manufacturer.
 - 1. High load fasteners and plates as recommended by manufacturer.
- I. Miscellaneous Accessories: Provide pourable sealers, preformed cone and vent sheet flashings, preformed inside and outside corner sheet flashings, T-joint covers, lap sealants, termination reglets, and other accessories required for a complete assembly.

2.5 COVER BOARDS

- A. Cover Boards: ASTM C1177, unprimed, glass-mat-faced, water-resistant gypsum substrate.
 - 1. Products: Subject to compliance with requirements, provide one of the following:
 - a. Georgia-Pacific Gypsum LLC: DensDeck Roof Boards.
 - b. National Gypsum Company: DEXcell Glass Mat Roof Board.
 - c. United States Gypsum Company: Securock Glass-Mat Roof Board.
 - d. Thickness: 1/2 inch.
- B. Fasteners: Factory-coated steel fasteners and metal or plastic plates complying with corrosion-resistance.
 - 1. Recycled Content: Postconsumer recycled content plus 1/2 of preconsumer recycled content not less than 50 percent.

2.6 ROOF INSULATION

- A. Preformed roof insulation boards manufactured or approved by roof membrane manufacturer.
- B. Polyisocyanurate Board Insulation: ASTM C1289, Type II, Class 1, Grade 2 or 3, closed cell, non-halogenated foam core with glass-fiber mat facer on both major surfaces.
 - 1. Manufacturers: Subject to compliance with requirements, provide one of the following:
 - a. Atlas Roofing Corporation: ACFoam II NH.
 - b. Carlisle SynTec Incorporated: InsulBase NH Polyiso.
 - c. Firestone Building Products: ISO 95+ GL.
 - d. Johns Manville: Flat & Tapered ENERGY 3.
 - e. Versico Incorporated: VersiCore MP-H NH Polyiso Insulation.
 - f. Approved substitution.
 - 2. Long Term Thermal Resistance (LTTR) Values: 5.7 per inch.
 - 3. Compressive Strength: 20 psi.
 - 4. Size: 48 by 48 inches.
 - 5. Thickness:
 - a. Base Layer: 1-1/2 inches.
 - b. Upper Layer: As required to meet thermal requirements.
- C. Tapered Insulation: Provide factory-tapered insulation boards to slope of 1/4 inch per 12 inches, unless otherwise indicated. Provide mitered boards for changes in slope direction.
 - 1. Minimum 1 inch coverage over polyisocyanurate board insulation.
- D. Provide preformed saddles, crickets, and other insulation shapes where indicated for sloping to drain. Fabricate to slopes indicated.

2.7 INSULATION ACCESSORIES

- A. Roof insulation accessories recommended by insulation manufacturer for intended use and compatibility with other roofing system components.
- B. Fasteners: Factory-coated steel fasteners with metal or plastic plates complying with corrosion-resistance, designed for fastening roof insulation to substrate, and acceptable to roofing system manufacturer.
- C. Insulation Adhesive: Insulation manufacturer's recommended adhesive formulated to attach roof insulation to substrate or to another insulation layer as follows:
 - 1. Modified asphaltic, asbestos-free, cold-applied adhesive.
 - 2. Bead-applied, low-rise, one-component or multicomponent urethane adhesive.
 - 3. Full-spread, spray-applied, low-rise, 2-component urethane adhesive.
 - 4. Verify adhesives and sealants comply with testing and product requirements of California Department of Public Health's "Standard Method for the Testing and Evaluation of Volatile Organic Chemical Emissions from Indoor Sources Using Environmental Chambers."

PART 3 - EXECUTION

3.1 EXAMINATION

- A. Examine substrates, areas, and conditions, with installer present, for compliance with requirements and other conditions affecting performance of Work:
 - 1. Verify that roof openings and penetrations are in place and curbs are set and braced and roof drain bodies are securely clamped in place.
 - 2. Verify that wood blocking, curbs, and nailers are securely anchored to roof deck at penetrations and terminations and that nailers match thicknesses of insulation.
- B. Proceed with installation only after unsatisfactory conditions have been corrected.

3.2 PREPARATION

- A. Clean substrate of dust, debris, moisture, and other substances detrimental to roofing installation according to roofing system manufacturer's written instructions. Remove sharp projections.
- B. Prevent materials from entering and clogging roof drains and conductors and from spilling or migrating onto surfaces of other construction. Remove roof-drain plugs when no Work is taking place or when rain is forecast.

3.3 INSTALLATION OF ROOFING, GENERAL

- A. Install roofing system according to roofing system manufacturer's written instructions, SPRI's Directory of Roof Assemblies listed roof assembly requirements, and FM Global Property Loss Prevention Data Sheet 1-29.
- B. Complete terminations and base flashings and provide temporary seals to prevent water from entering completed sections of roofing system at end of workday or when rain is forecast. Remove and discard temporary seals before beginning Work on adjoining roofing.
- C. Coordinate installation and transition of roofing system component serving as an air barrier with air barrier specified under Section 072715 – Nonbituminous Self-Adhering Sheet Air Barriers.

3.4 INSTALLATION OF VAPOR-RETARDER

- A. Self-Adhering-Sheet Vapor Retarder: Prime substrate if required by manufacturer. Install self-adhering-sheet vapor retarder over area to receive vapor retarder, side lapping a minimum of 3-1/2 inches, and end lapping each sheet a minimum 6 inches.
 - 1. Extend vertically up parapet walls and projections to a minimum height equal to height of insulation and cover board.
 - 2. Seal laps by rolling.
- B. Completely seal vapor retarder at terminations, obstructions, and penetrations to prevent air movement into roofing system.

3.5 INSTALLATION OF INSULATION

- A. Coordinate installing roofing system components so insulation is not exposed to precipitation or left exposed at end of workday.
- B. Comply with roofing system and insulation manufacturer's written instructions for installing roof insulation.
- C. Install base layer of insulation with joints staggered not less than 24 inches in adjacent rows.
 - 1. Trim insulation neatly to fit around penetrations and projections, and to fit tight to intersecting sloping roof decks.
 - 2. Make joints between adjacent insulation boards not more than 1/4 inch in width.
 - 3. At internal roof drains, slope insulation to create a square drain sump with each side equal to diameter of drain bowl plus 24 inches.
 - a. Trim insulation so that water flow is unrestricted.
 - 4. Fill gaps exceeding 1/4 inch with insulation.
 - 5. Cut and fit insulation within 1/4 inch of nailers, projections, and penetrations.
 - 6. Fasten insulation according to requirements SPRI's Directory of Roof Assemblies for specified Wind Uplift Load Capacity.
 - 7. Fasten insulation to resist uplift pressure at corners, perimeter, and field of roof.

8. Install upper layers of insulation and tapered insulation with joints of each layer offset not less than 12 inches from previous layer of insulation.
 - a. 48 by 48 Inch Insulation Boards: Staggered end joints within each layer not less than 24 inches in adjacent rows.
 - b. Trim insulation neatly to fit around penetrations and projections, and to fit tight to intersecting sloping roof decks.
 - c. Make joints between adjacent insulation boards not more than 1/4 inch in width.
 - d. At internal roof drains, slope insulation to create a square drain sump with each side equal to the diameter of the drain bowl plus 24 inches.
 - 1) Trim insulation so that water flow is unrestricted.
 - e. Fill gaps exceeding 1/4 inch with insulation.
 - f. Cut and fit insulation within 1/4 inch of nailers, projections, and penetrations.
 - g. Adhere each layer of insulation to substrate using adhesive according to SPRI's Directory of Roof Assemblies listed roof assembly requirements for specified Wind Uplift Load Capacity and FM Global Property Loss Prevention Data Sheet 1-29, as follows:
 - 1) Set each layer of insulation in ribbons of bead-applied insulation adhesive, firmly pressing and maintaining insulation in place.
 - 2) Set each layer of insulation in a uniform coverage of full-spread insulation adhesive, firmly pressing and maintaining insulation in place.

3.6 INSTALLATION OF COVER BOARD

- A. Install cover boards over insulation with long joints in continuous straight lines with end joints staggered between rows. Offset joints of insulation below a minimum of 6 inches in each direction.
 1. Trim cover board neatly to fit around penetrations and projections, and to fit tight to intersecting sloping roof decks.
 2. At internal roof drains, conform to slope of drain sump.
 - a. Trim cover board so that water flow is unrestricted.
 3. Cut and fit cover board tight to nailers, projections, and penetrations.
 4. Adhere cover board to substrate using adhesive according to SPRI's Directory of Roof Assemblies listed roof assembly requirements for specified Wind Uplift Load Capacity and FM Global Property Loss Prevention Data Sheet 1-29 for specified Windstorm Resistance Classification, as follows:
 - a. Set cover board in ribbons of bead-applied insulation adhesive, firmly pressing and maintaining insulation in place.
 - b. Set cover board in a uniform coverage of full-spread insulation adhesive, firmly pressing and maintaining insulation in place.

3.7 INSTALLATION OF ADHERED ROOF MEMBRANE

- A. Start installation of roofing in presence of roofing system manufacturer's technical personnel and Owners testing and inspection agency.
- B. Unroll roof membrane and allow to relax before installing.
- C. Adhere roof membrane over area to receive roofing according to roofing system manufacturer's written instructions.
- D. Accurately align roof membrane and maintain uniform side and end laps of minimum dimensions required by manufacturer. Stagger end laps.
- E. Bonding Adhesive: Apply to substrate and underside of roof membrane at rate required by manufacturer, and allow to partially dry before installing roof membrane. Do not apply to splice area of roof membrane.
- F. In addition to adhering, mechanically fasten roof membrane securely at terminations, penetrations, and perimeter of roofing.

- G. Apply roof membrane with side laps shingled with slope of roof deck where possible.
- H. Seams: Clean seam areas, overlap roofing, and hot-air weld side and end laps of roof membrane and sheet flashings to ensure a watertight seam installation.
 - 1. Test lap edges with probe to verify seam weld continuity.
 - 2. Apply lap sealant to seal cut edges of roof membrane and sheet flashings.
 - 3. Verify field strength of seams a minimum of twice daily, or as required by roof system manufacturer to maintain specified warranty, and repair seam sample areas.
- I. Repair tears, voids, and lapped seams in roof membrane that do not comply with requirements.
- J. Spread sealant bed over deck drain flange at roof drains and securely seal roof membrane in place with clamping ring.

3.8 INSTALLATION OF BASE FLASHING

- A. Install sheet flashings and preformed flashing accessories and adhere to substrates per roofing system manufacturer's written instructions.
- B. Apply bonding adhesive to substrate and underside of sheet flashing at required rate and allow to partially dry. Do not apply to seam area of flashing.
- C. Flash penetrations and field-formed inside and outside corners with cured or uncured sheet flashing.
- D. Clean seam areas, overlap, and firmly roll sheet flashings into the adhesive. Hot-air weld side and end laps to ensure a watertight seam installation.
- E. Terminate and seal top of sheet flashings and mechanically anchor to substrate through termination bars.

3.9 REPAIR

- A. Correct deficiencies in or remove roofing system that does not comply with requirements; repair substrates; and repair or reinstall roofing system to a condition free of damage and deterioration at time of Substantial Completion and according to warranty requirements.

3.10 FIELD QUALITY CONTROL

- A. Testing Agency: Owner will engage qualified testing agency to be on site during course of this Work to inspect substrate conditions, surface preparation, membrane application, flashings, protection, and drainage components, and to furnish reports to Architect.
 - 1. Arrange for daily site attendance of roofing and insulation material manufacturers during installation of roofing Work.
- B. Final Roof Inspection: Arrange for roofing system manufacturer's technical personnel to inspect roofing installation on completion or Work and prior to final payment in presence of Architect, Owner, and Owner's envelope consultant. Record and immediately correct discrepancies. Final payment will not be issued until manufacturer has submitted written approval of Work, and closeout submittals, including roof operation and maintenance manuals and warranties, have been received by Architect.
 - 1. Notify Architect and Owner 48 hours in advance of date and time of inspection.
- C. Field-verify strength of membrane seams a minimum of twice daily according to manufacturer's written instructions, and repair seam sample areas after verification process.
- D. Repair or remove and replace components of roofing system where inspections indicate that they do not comply with specified requirements.
- E. Additional inspections, at Contractor's expense, will be performed to determine compliance of replaced or additional Work with specified requirements.

3.11 CLEANING

- A. Clean overspray and spillage from adjacent construction using cleaning agents and procedures recommended by manufacturer of affected construction.

3.12 PROTECTION

- A. Protect roofing system from damage and wear during remainder of construction period. When remaining construction will not affect or endanger roofing, inspect roofing for deterioration and damage, describing its nature and extent in a written report, with copies to Architect and Owner.

END OF SECTION 075423

SECTION 076200
SHEET METAL FLASHING AND TRIM

PART 1 - GENERAL

1.1 SUMMARY

- A. Section Includes:
 - 1. Manufactured through-wall flashing with counterflashing.
 - 2. Manufactured reglets with counterflashing.
 - 3. Formed roof-drainage sheet metal fabrications.
 - 4. Formed low-slope roof sheet metal fabrications.
 - 5. Formed steep-slope roof sheet metal fabrications.
 - 6. Formed wall sheet metal fabrications.
- B. Related Requirements:
 - 1. Section 073013 – Roofing underlayments.
 - 2. Section 076500 – Flexible Flashings.

1.2 ADMINISTRATIVE REQUIREMENTS

- A. Coordination:
 - 1. Coordinate sheet metal flashing and trim layout and seams with sizes and locations of penetrations to be flashed, and joints and seams in adjacent materials.
 - 2. Coordinate sheet metal flashing and trim installation with adjoining roofing and wall materials, joints, and seams to provide leakproof, secure, and noncorrosive installation.
- B. Preinstallation Meetings: Conduct meeting at Project site.
 - 1. Review construction schedule. Verify availability of materials, Installer's personnel, equipment, and facilities needed to make progress and avoid delays.
 - 2. Review special roof details, roof drainage, roof-penetration flashing, equipment curbs, and condition of other construction that affect sheet metal flashing and trim.
 - 3. Review requirements for insurance and certificates if applicable.
 - 4. Review sheet metal flashing observation and repair procedures after flashing installation.

1.3 ACTION SUBMITTALS

- A. Product Data: For each type of product.
 - 1. Include construction details, material descriptions, dimensions of individual components and profiles, and finishes for each manufactured product and accessory.
- B. Shop Drawings: For sheet metal flashing and trim.
 - 1. Include plans, elevations, sections, and attachment details.
 - 2. Detail fabrication and installation layouts, expansion-joint locations, and keyed details. Distinguish between shop- and field-assembled Work.
 - 3. Include identification of material, thickness, weight, and finish for each item and location in Project.
 - 4. Include details for the following conditions:
 - a. Forming sheet metal flashing and trim, including profiles, shapes, seams, and dimensions.
 - b. Joining, supporting, and securing sheet metal flashing and trim, including layout of fasteners, cleats, clips, and other attachments. Include pattern of seams.
 - c. Termination points and assemblies.

- d. Expansion joints and expansion-joint covers, including showing direction of expansion and contraction from fixed points.
 - e. Roof-penetration flashing.
 - f. Edge conditions, including eaves, ridges, valleys, rakes, crickets, and counterflashings as applicable.
 - g. Special conditions.
 - h. Connections to adjoining Work.
5. Detail formed flashing and trim at a scale of not less than 1-1/2 inches per 12 inches.
- C. Samples for Verification: For each type of exposed finish.
- 1. Sheet Metal Flashing: 12 inches long by actual width of unit, including finished seam and in required profile. Include fasteners, cleats, clips, closures, and other attachments.
 - 2. Trim, Metal Closures, Expansion Joints, Joint Intersections, and Miscellaneous Fabrications: 12 inches long and in required profile. Include fasteners and other exposed accessories.
 - 3. Unit-Type Accessories and Miscellaneous Materials: Full-size Sample.
- 1.4 INFORMATIONAL SUBMITTALS
- A. Qualification Data: For fabricator.
 - B. Product Certificates: For each type of coping and roof edge flashing that is SPRI ES-1 tested.
 - C. Product Test Reports: For each product, for tests performed by a qualified testing agency.
 - D. Sample Warranty: For special warranty.
- 1.5 CLOSEOUT SUBMITTALS
- A. Maintenance Data: For sheet metal flashing and trim, and its accessories, to include in maintenance manuals.
 - B. Special warranty.
- 1.6 QUALITY ASSURANCE
- A. Fabricator Qualifications: Employs skilled workers who custom fabricate sheet metal flashing and trim similar to that required for this Project and whose products have a record of successful in-service performance.
 - 1. For copings and roof edge flashings that are SPRI ES-1 tested, shop shall be listed as able to fabricate required details as tested and approved.
 - B. Mockups: Build mockups to verify selections made under Sample submittals, to demonstrate aesthetic effects, and to set quality standards for fabrication and installation.
 - 1. Build mockup of typical roof edge, approximately 10 feet long, including supporting construction cleats, seams, attachments, underlayment, and accessories.
 - 2. Build mockup of exterior wall flashings.
 - 3. Approval of mockups does not constitute approval of deviations from Contract Documents contained in mockups unless Architect specifically approves such deviations in writing.
 - 4. Subject to compliance with requirements, approved mockups may become part of completed Work if undisturbed at time of Substantial Completion.
- 1.7 DELIVERY, STORAGE, AND HANDLING
- A. Do not store sheet metal flashing and trim materials in contact with other materials that might cause staining, denting, or other surface damage.
 - 1. Store sheet metal flashing and trim materials away from uncured concrete and masonry.
 - 2. Protect stored sheet metal flashing and trim from contact with water.

- B. Protect strippable protective covering on sheet metal flashing and trim from exposure to sunlight and high humidity, except to extent necessary for period of sheet metal flashing and trim installation.

1.8 WARRANTY

- A. Special Warranty on Finishes: Manufacturer agrees to repair finish or replace sheet metal flashing and trim that shows evidence of deterioration of factory-applied finishes within specified warranty period.
 - 1. Exposed Panel Finish: Deterioration includes the following:
 - a. Color fading more than 5 Hunter units when tested per ASTM D2244.
 - b. Chalking in excess of a No. 8 rating when tested per ASTM D4214.
 - c. Cracking, checking, peeling, or failure of paint to adhere to bare metal.
 - 2. Finish Warranty Period: 20 years from date of Substantial Completion.

PART 2 - PRODUCTS

2.1 PERFORMANCE CRITERIA

- A. General: Sheet metal flashing and trim assemblies shall withstand wind loads, structural movement, thermally induced movement, and exposure to weather without failure due to defective manufacture, fabrication, installation, or other defects in construction. Completed sheet metal flashing and trim shall not rattle, leak, or loosen, and shall remain watertight.
- B. Sheet Metal Standard for Flashing and Trim: Comply with NRCA's "The NRCA Roofing Manual" and SMACNA's "Architectural Sheet Metal Manual" requirements for dimensions and profiles shown unless more stringent requirements are indicated.
- C. SPRI Wind Design Standard: Manufacture and install copings and roof edge flashing tested according to SPRI ES-1 and capable of resisting the following design pressure
 - 1. Design Pressure: As indicated on Drawings.
- D. Recycled Content: Postconsumer recycled content plus 1/2 of preconsumer recycled content not less than 50 percent.
- E. Thermal Movements: Allow for thermal movements from ambient and surface temperature changes to prevent buckling, opening of joints, overstressing of components, failure of joint sealants, failure of connections, and other detrimental effects. Base calculations on surface temperatures of materials due to both solar heat gain and nighttime-sky heat loss.
 - 1. Temperature Change (Range): 120 deg F, ambient; 180 deg F, material surfaces.

2.2 SHEET METALS

- A. General: Protect mechanical and other finishes on exposed surfaces from damage by applying a strippable, temporary protective film before shipping.
- B. Metallic-Coated Steel Sheet: Provide zinc-coated (galvanized) steel sheet according to ASTM A653, G90 coating designation, prepainted by coil-coating process to comply with ASTM A755.
 - 1. Recycled Content: Postconsumer recycled content plus 1/2 of preconsumer recycled content not less than 25 percent.
 - 2. Surface: Smooth, flat.
 - 3. Exposed Coil-Coated Finish:
 - a. 3-Coat Fluoropolymer: AAMA 621. Fluoropolymer finish containing not less than 70 percent PVDF resin by weight in both color coat and clear topcoat. Prepare, pretreat, and apply coating to exposed metal surfaces to comply with coating and resin manufacturers' written instructions.
 - b. Color: Selected by Architect from manufacturer's full range.

4. Concealed Finish: Pretreat with manufacturer's standard white or light-colored acrylic or polyester backer finish, consisting of prime coat and wash coat with a minimum total dry film thickness of 0.5 mil.

2.3 UNDERLAYMENT MATERIALS

- A. Self-Adhering, High-Temperature Sheet and Synthetic Roofing Underlayment: Specified in Section 073013 – Roofing Underlayments.

2.4 MISCELLANEOUS MATERIALS

- A. Resin Flashing System: PMMA-type flashing as specified in Section 076500 – Flexible Flashing.
- B. General: Provide materials and types of fasteners, solder, protective coatings, sealants, and other miscellaneous items as required for complete sheet metal flashing and trim installation and as recommended by manufacturer of primary sheet metal or manufactured item unless otherwise indicated.
- C. Fasteners: Wood screws, annular threaded nails, self-tapping screws, self-locking rivets and bolts, and other suitable fasteners designed to withstand design loads and recommended by manufacturer of primary sheet metal or manufactured item.
 1. General: Blind fasteners or self-drilling screws, gasketed, with hex-washer head.
 - a. Exposed Fasteners: Heads matching color of sheet metal using plastic caps or factory-applied coating. Provide metal-backed EPDM or PVC sealing washers under heads of exposed fasteners bearing on weather side of metal.
 - b. Blind Fasteners: High-strength aluminum or stainless-steel rivets suitable for metal being fastened.
 - c. Spikes and Ferrules: Same material as gutter; with spike with ferrule matching internal gutter width.
 2. Fasteners for Zinc-Coated (Galvanized) Steel Sheet: Hot-dip galvanized steel per ASTM A153 or ASTM F2329 or Series 300 stainless steel.
 3. Fasteners for Aluminum Sheet: Aluminum or Series 300 stainless steel.
 4. Fasteners for Stainless-Steel Sheet: Series 300 stainless steel.
- D. Solder:
 1. For Stainless Steel: ASTM B32, Grade Sn60, with an acid flux of type recommended by stainless-steel sheet manufacturer.
 2. For Zinc-Coated (Galvanized) Steel: ASTM B32, Grade Sn50, 50 percent tin and 50 percent lead or Grade Sn60, 60 percent tin and 40 percent lead.
- E. Sealant Tape: Pressure-sensitive, 100 percent solids, polyisobutylene compound sealant tape with release-paper backing. Provide permanently elastic, nonsag, nontoxic, nonstaining tape 1/2 inch wide and 1/8 inch thick.
- F. Elastomeric Sealant: ASTM C920, elastomeric polymer sealant; of type, grade, class, and use classifications required to seal joints in sheet metal flashing and trim and remain watertight.
- G. Butyl Sealant: ASTM C1311, single-component, solvent-release butyl rubber sealant; polyisobutylene plasticized; heavy bodied for hooked-type expansion joints with limited movement.
- H. Asphalt Roofing Cement: ASTM D4586, asbestos free, of consistency required for application.
- I. Friction-Resistant Tape: Ultra-high modular weight (UHMW) polyethylene tape with adhesive on 1 side, in thickness as required to allow free movement in slip joints to prevent metal-to-metal friction.

- J. Gutter Liner: Heat-resistant, PVC roofing material designed with heat-weldable seams and resistance to damage from heat tape.
 - 1. Thickness: Minimum 0.050 inch.
 - 2. Color: White.

2.5 MANUFACTURED SHEET METAL FLASHING AND TRIM

- A. Reglets: Units of type, material, and profile indicated, formed to provide secure interlocking of separate reglet and counterflashing pieces, and compatible with flashing indicated with factory-mitered and -welded corners and junctions with interlocking counterflashing on exterior face, of same metal as reglet.
 - 1. Source Limitations: Obtain reglets from single source from single manufacturer.
 - 2. Material: Galvanized Steel, 0.028 inch thick.
 - 3. Concrete Type: Provide temporary closure tape to keep reglet free of concrete materials, special fasteners for attaching reglet to concrete forms, and guides to ensure alignment of reglet section ends.
 - a. Basis-of-Design Product: Subject to compliance with requirements, provide the following:
 - 1) Fry Reglet Corporation: Springlok Type CO – Concrete.
 - 2) Approved substitution.
 - 4. Surface-Mounted Type: Not acceptable.
 - 5. Accessories:
 - a. Flexible-Flashing Retainer: Provide resilient plastic or rubber accessory to secure flexible flashing in reglet where clearance does not permit use of standard metal counterflashing or where Drawings show reglet without metal counterflashing.
 - b. Counterflashing Wind-Restraint Clips: Provide clips to be installed before counterflashing to prevent wind uplift of counterflashing lower edge.
 - 6. Finish: Mill.

2.6 FABRICATION, GENERAL

- A. General: Custom fabricate sheet metal flashing and trim to comply with details shown and recommendations in cited sheet metal standard that apply to design, dimensions, geometry, metal thickness, and other characteristics of item required. Shop-fabricate sheet metal flashing and trim to greatest extent possible.
 - 1. Fabricate sheet metal flashing and trim in thickness or weight needed to comply with performance requirements, but not less than that specified for each application and metal.
 - 2. Obtain field measurements for accurate fit before shop fabrication.
 - 3. Form sheet metal flashing and trim to fit substrates without excessive oil canning, buckling, and tool marks; true to line, levels, and slopes; and with exposed edges folded back to form hems.
 - 4. Conceal fasteners and expansion provisions where possible. Do not use exposed fasteners on faces exposed to view.
- B. Fabrication Tolerances: Fabricate sheet metal flashing and trim that is capable of installation to a tolerance of 1/4 inch in 20 feet on slope and location lines indicated on Drawings and within 1/8 inch offset of adjoining faces and of alignment of matching profiles.
- C. Fabrication Tolerances: Fabricate sheet metal flashing and trim that is capable of installation to tolerances specified in MCA's "Guide Specification for Residential Metal Roofing."
- D. Expansion Provisions: Form metal for thermal expansion of exposed flashing and trim.
 - 1. Form expansion joints of intermeshing hooked flanges, not less than 1 inch deep, filled with butyl sealant concealed within joints.
 - 2. Use lapped expansion joints only where indicated on Drawings.

- E. Sealant Joints: Where movable, nonexpansion-type joints are required, form metal to provide for proper installation of elastomeric sealant according to cited sheet metal standard.
- F. Fabricate cleats and attachment devices from same material as accessory being anchored or from compatible, noncorrosive metal.
- G. Fabricate cleats and attachment devices of sizes as recommended by cited sheet metal standard for application, but not less than thickness of metal being secured.
- H. Seams:
 - 1. Fabricate nonmoving seams with flat-lock seams. Tin edges to be seamed, form seams, and solder.
 - 2. Fabricate nonmoving seams with flat-lock seams. Form seams and seal with elastomeric sealant unless otherwise recommended by sealant manufacturer for intended use. Rivet joints where necessary for strength.
- I. Do not use graphite pencils to mark metal surfaces.

2.7 ROOF-DRAINAGE SHEET METAL FABRICATIONS

- A. Hanging Gutters:
 - 1. Fabricate to cross section indicated, complete with end pieces, outlet tubes, and other accessories as required.
 - 2. Fabricate in minimum 96 inch long sections.
 - 3. Furnish flat-stock gutter brackets and gutter spacers and straps fabricated from same metal as gutters, of size recommended by cited sheet metal standard but with thickness not less than twice gutter thickness unless indicated otherwise.
 - 4. Fabricate expansion joints, expansion-joint covers, and gutter accessories from same metal as gutters. Shop-fabricate interior and exterior corners.
 - 5. Gutter Profile: As indicated on Drawings.
 - 6. Expansion Joints: Butt type with cover plate.
 - 7. Accessories: Cast aluminum dome strainers in sizes and profiles to fit gutters, conductor heads, and downspouts.
 - a. Provide with expansion anchor fitting for push-on pipe connections.
 - b. Wire strainers are not acceptable.
 - 8. Gutters with Girth up to 15 inches: Fabricate from the following materials:
 - a. Galvanized Steel: 0.022 inch thick.
 - 9. Gutters with Girth 16 to 20 inches: Fabricate from the following materials:
 - a. Galvanized Steel: 0.028 inch thick.
 - 10. Gutters with Girth 21 to 25 inches: Fabricate from the following materials:
 - a. Galvanized Steel: 0.034 inch thick.
 - 11. Gutters with Girth 26 to 30 inches: Fabricate from the following materials:
 - a. Galvanized Steel: 0.040 inch thick.
 - 12. Gutters with Girth 31 to 35 inches: Fabricate from the following materials:
 - a. Galvanized Steel: 0.052 inch thick.
- B. Built-in Gutters: Fabricate to cross section indicated, with riveted and soldered joints, complete with end pieces, outlet tubes, and other special accessories as required. Fabricate in minimum 96 inch long sections. Fabricate expansion joints and accessories from same metal as gutters unless otherwise indicated.
 - 1. Fabricate gutters with built-in expansion joints.
 - 2. Fabricate from zinc, 0.032 inch thick.
 - 3. Accessories: Cast aluminum dome strainers in sizes and profiles to fit gutters, conductor heads, and downspouts.
 - a. Provide with expansion anchor fitting for push-on pipe connections.
 - b. Wire strainers are not acceptable.

- C. Downspouts: Fabricate round downspouts, unless indicated otherwise, to dimensions indicated on Drawings, complete with mitered elbows. Furnish with metal hangers from same material as downspouts and anchors.
 - 1. Fabricate from the following materials:
 - a. Galvanized Steel: 0.022 inch thick.
 - 2. Downspout Boots: Contoured interior flow design with no boxed corners, weld seams or choke points; include integral lug slots and stainless steel fasteners
 - a. Material: Gray cast iron, ASTM A48, Class 30.
 - b. Configuration: Offset, angular, or 90-degree configuration as indicated on Drawings.
 - c. Finish: Manufacturer's standard powder coating in color to match downspouts.
 - 3. Downspout Connections to Storm Drainage System: As indicated on civil Drawings.
 - a. Downspout Connector: Neoprene coupler boot with stainless steel clamp unless indicated otherwise.

2.8 LOW-SLOPE ROOF SHEET METAL FABRICATIONS

- A. Roof Edge Flashing (Gravel Stop): Fabricate in minimum 96 inch long, but not exceeding 12 foot long sections. Furnish with 6 inch wide, joint cover plates. Shop fabricate interior and exterior corners.
 - 1. Joint Style: Butted with expansion space and 6 inch wide, concealed backup plate.
 - 2. Fabricate with scuppers spaced 10 feet apart, to dimensions required with 4 inch wide flanges and base extending 4 inches beyond cant or tapered strip into field of roof. Fasten gravel guard angles to base of scupper.
 - 3. Fabricate from the following materials:
 - a. Galvanized Steel: 0.028 inch thick.
- B. Roof-to-Wall Transition Expansion-Joint Cover: Fabricate from the following materials:
 - 1. Galvanized Steel: 0.034 inch thick.
- C. Base Flashing: Fabricate from the following materials:
 - 1. Galvanized Steel: 0.028 inch thick.
- D. Counterflashing: Fabricate from the following materials:
 - 1. Galvanized Steel: 0.022 inch thick.
- E. Flashing Receivers: Fabricate from the following materials:
 - 1. Galvanized Steel: 0.022 inch thick.
- F. Roof-Penetration Flashing: Fabricate from the following materials:
 - 1. Stainless Steel: 0.019 inch thick.

2.9 STEEP-SLOPE ROOF SHEET METAL FABRICATIONS

- A. Apron, Step, Cricket, and Backer Flashing: Fabricate from the following materials:
 - 1. Galvanized Steel: 0.022 inch thick.
- B. Valley Flashing: Fabricate from the following materials:
 - 1. Galvanized Steel: 0.028 inch thick.
- C. Drip Edges: Fabricate from the following materials:
 - 1. Galvanized Steel: 0.028 inch thick.
- D. Eave, Rake, Ridge, and Hip Flashing: Fabricate from the following materials:
 - 1. Galvanized Steel: 0.028 inch thick.
- E. Counterflashing: Fabricate from the following materials:
 - 1. Galvanized Steel: 0.028 inch thick.

- F. Flashing Receivers: Fabricate from the following materials:
 - 1. Galvanized Steel: 0.028 inch thick.
- G. Roof-Penetration Flashing: Fabricate from the following materials:
 - 1. Galvanized Steel: 0.028 inch thick.
- H. Roof-Penetration Flashing: Fabricate from the following materials:
 - 1. Stainless Steel: 0.019 inch thick.

2.10 WALL SHEET METAL FABRICATIONS

- A. Through-Wall Flashing: Fabricate continuous flashings in minimum 96 inch long, but not exceeding 12 foot long, sections, under copings, and at shelf angles. Fabricate discontinuous lintel, sill, and similar flashings to extend 6 inches beyond each side of wall openings; and form with 2 inch high end dams. Fabricate from the following materials:
 - 1. Stainless Steel: 0.025 inch thick.
- B. Opening Flashings in Frame Construction: Fabricate head, sill, jamb, and similar flashings to extend 4 inches beyond wall openings. Form head and sill flashing with 2 inch high end dams. Fabricate from the following materials:
 - 1. Stainless Steel: 0.025 inch thick.
- C. Wall Expansion-Joint Cover: Fabricate from the following materials:
 - 1. Stainless Steel: 0.025 inch thick.

PART 3 - EXECUTION

3.1 ACCEPTABLE FABRICATORS

- A. Contractor's option to provide shop-fabricated metal copings. Fabricate and install copings according to SPRI ES-1 requirements.

3.2 EXAMINATION

- A. Examine substrates, areas, and conditions, with Installer present, for compliance with requirements for installation tolerances, substrate, and other conditions affecting performance of Work.
 - 1. Verify compliance with requirements for installation tolerances of substrates.
 - 2. Verify that substrate is sound, dry, smooth, clean, sloped for drainage, and securely anchored.
 - 3. Verify that air- or water-resistant barriers have been installed over sheathing or backing substrate to prevent air infiltration or water penetration.
 - 4. Proceed with installation only after unsatisfactory conditions have been corrected.

3.3 INSTALLATION OF UNDERLAYMENT

- A. Synthetic Underlayment: Install synthetic underlayment, wrinkle free, in accordance with manufacturers' written instructions, and using adhesive where possible to minimize use of mechanical fasteners under sheet metal.
 - 1. Lap horizontal joints not less than 4 inches.
 - 2. Lap end joints not less than 12 inches.
 - 3. Location: Over entire roof area.
- B. Self-Adhering, High-Temperature Sheet Underlayment:
 - 1. Install self-adhering, high-temperature sheet underlayment; wrinkle free.
 - 2. Prime substrate if recommended by underlayment manufacturer.
 - 3. Comply with temperature restrictions of underlayment manufacturer for installation; use primer for installing underlayment at low temperatures.

4. Apply in shingle fashion to shed water, with end laps of not less than 6 inches staggered 24 inches between courses.
5. Overlap side edges not less than 3-1/2 inches. Roll laps and edges with roller.
6. Roll laps and edges with roller.
7. Cover underlayment within 14 days.
8. Apply over roof area indicated below:
 - a. Roof perimeter for a distance up from eaves of 36 inches beyond interior wall line.
 - b. Valleys, from lowest point to highest point, for a distance on each side of 18 inches. Overlap ends of sheets not less than 6 inches.
 - c. Rake edges for a distance of 18 inches.
 - d. Hips and ridges for a distance on each side of 12 inches.

3.4 INSTALLATION, GENERAL

- A. General: Anchor sheet metal flashing and trim and other components of Work securely in place, with provisions for thermal and structural movement. Use fasteners, solder, protective coatings, separators, sealants, and other miscellaneous items as required to complete sheet metal flashing and trim system.
 1. Install sheet metal flashing and trim true to line, levels, and slopes. Provide uniform, neat seams with minimum exposure of solder, welds, and sealant.
 2. Install sheet metal flashing and trim to fit substrates and to result in watertight performance. Verify shapes and dimensions of surfaces to be covered before fabricating sheet metal.
 3. Space cleats not more than 12 inches apart. Attach each cleat with at least 2 fasteners. Bend tabs over fasteners.
 4. Install exposed sheet metal flashing and trim with limited oil canning, and free of buckling and tool marks.
 5. Torch cutting of sheet metal flashing and trim is not permitted.
 6. Do not use graphite pencils to mark metal surfaces.
- B. Metal Protection: Where dissimilar metals contact each other, or where metal contacts pressure-treated wood or other corrosive substrates, protect against galvanic action or corrosion by painting contact surfaces with bituminous coating or by other permanent separation as recommended by sheet metal manufacturer or cited sheet metal standard.
 1. Coat concealed side of uncoated aluminum and stainless-steel sheet metal flashing and trim with bituminous coating where flashing and trim will contact wood, ferrous metal, or cementitious construction.
 2. Underlayment: See Section 073013 – Roofing Underlayments.
- C. Expansion Provisions: Provide for thermal expansion of exposed flashing and trim. Space movement joints at maximum of 10 feet with no joints within 24 inches of corner or intersection.
 1. Form expansion joints of intermeshing hooked flanges, not less than 1 inch deep, filled with sealant concealed within joints.
- D. Fasteners: Use fastener sizes that penetrate substrate not less than recommended by fastener manufacturer to achieve maximum pull-out resistance.
 1. Conceal fasteners and expansion provisions where possible in exposed Work and locate to minimize possibility of leakage. Cover and seal fasteners and anchors as required for a tight installation.
- E. Seal joints as required for watertight construction.
 1. Use sealant-filled joints unless otherwise indicated.
 - a. Embed hooked flanges of joint members not less than 1 inch into sealant.
 - b. Form joints to completely conceal sealant.
 - c. When ambient temperature at time of installation is between 40 and 70 d F, set joint members for 50 percent movement each way.
 - d. Adjust setting proportionately for installation at higher ambient temperatures.

2. Prepare joints and apply sealants to comply with requirements in Section 079200 – Joint Sealants.
- F. Soldered Joints: Clean surfaces to be soldered, removing oils and foreign matter. Pre-tin edges of sheets with solder to width of 1-1/2 inches; however, reduce pre-tinning where pre-tinned surface would show in completed Work.
1. Do not solder metallic-coated steel and aluminum sheet.
 2. Do not use torches for soldering.
 3. Heat surfaces to receive solder, and flow solder into joint. Fill joint completely. Completely remove flux and spatter from exposed surfaces.
 4. Stainless-Steel Soldering:
 - a. Tin edges of uncoated sheets using solder recommended for stainless steel and acid flux.
 - b. Promptly remove acid flux residue from metal after tinning and soldering.
 - c. Comply with solder manufacturer's recommended methods for cleaning and neutralization.
- 3.5 ROOF-DRAINAGE SYSTEM INSTALLATION
- A. General: Install sheet metal roof-drainage items to produce complete roof-drainage system according to cited sheet metal standard unless otherwise indicated. Coordinate installation of roof perimeter flashing with installation of roof-drainage system.
- B. Hanging Gutters: Join sections with riveted and soldered joints or joints sealed with sealant. Provide for thermal expansion. Attach gutters at eave or fascia to firmly anchor them in position. Provide end closures and seal watertight with sealant. Slope to downspouts.
1. Anchor back of gutter that extends onto roof deck with cleats spaced not more than 24 inches apart.
 2. Anchor gutter with gutter brackets spaced not more than 18 inches apart to roof deck, unless otherwise indicated, and loosely lock to front gutter bead.
 3. Install gutter with expansion joints at locations indicated, but not exceeding, 50 feet apart. Install expansion-joint caps.
- C. Built-in Gutters: Join sections with riveted and soldered joints. Provide for thermal expansion. Slope to downspouts. Provide end closures and seal watertight with sealant.
1. Install underlayment layer in built-in gutter trough and extend to drip edge at eaves and under underlayment on roof sheathing. Lap sides minimum of 2 inches over underlying course. Lap ends minimum of 4 inches. Stagger end laps between succeeding courses at least 72 inches. Fasten with roofing nails. Install slip sheet over underlayment.
 2. Anchor back of gutter that extends onto roof deck with cleats spaced not more than 18 inches apart.
 3. Install gutter with expansion joints at locations indicated, but not exceeding, 50 feet apart. Install expansion-joint caps.
- D. Downspouts: Join sections with 1-1/2- inch telescoping joints.
1. Provide hangers with fasteners designed to hold downspouts securely to walls. Locate hangers at top and bottom and at approximately 60 inches on center.
 2. Connect downspouts to underground drainage system.
 3. Provide elbows at base of downspout to direct water away from building.
- E. Conductor Heads: Anchor securely to wall, with elevation of conductor head rim at minimum of 1 inch below gutter discharge.
- F. Expansion-Joint Covers: Install expansion-joint covers at locations and of configuration indicated. Lap joints minimum of 4 inches in direction of water flow.

3.6 ROOF FLASHING INSTALLATION

- A. General: Install sheet metal flashing and trim to comply with performance requirements, sheet metal manufacturer's written installation instructions, and cited sheet metal standard.
 - 1. Provide concealed fasteners where possible, and set units true to line, levels, and slopes.
 - 2. Install Work with laps, joints, and seams that are permanently watertight and weather resistant.
- B. Roof Edge Flashing: Anchor to resist uplift and outward forces according to recommendations in cited sheet metal standard unless otherwise indicated. Interlock bottom edge of roof edge flashing with continuous cleat anchored to substrate at staggered 3 inch centers.
- C. Pipe or Post Counterflashing: Install counterflashing umbrella with close-fitting collar with top edge flared for elastomeric sealant, extending minimum of 4 inches over base flashing. Install stainless-steel draw band and tighten.
- D. Counterflashing: Coordinate installation of counterflashing with installation of base flashing.
 - 1. Insert counterflashing in reglets or receivers and fit tightly to base flashing.
 - 2. Extend counterflashing inches over base flashing.
 - 3. Lap counterflashing joints a minimum of 4 inches.
 - 4. Secure in a waterproof manner by means of snap-in installation and sealant or lead wedges and sealant, or interlocking folded seam or blind rivets and sealant unless indicated otherwise.
- E. Roof-Penetration Flashing: Coordinate installation of roof-penetration flashing with installation of roofing and other items penetrating roof. Seal with butyl sealant and clamp flashing to pipes that penetrate roof.

3.7 WALL FLASHING INSTALLATION

- A. Install sheet metal wall flashing to intercept and exclude penetrating moisture according to cited sheet metal standard unless otherwise indicated. Coordinate installation of wall flashing with installation of wall-opening components such as windows, doors, and louvers.
- B. Through-Wall Flashing: Installation of through-wall flashing is specified in Section 042000 – Unit Masonry.
- C. Opening Flashings in Frame Construction: Install continuous head, sill, jamb, and similar flashings to extend 4 inches beyond wall openings.
- D. Reglets: Installation of reglets is specified in Section 033000 – Cast-in-Place Concrete or Section 042000 – Unit Masonry.

3.8 MISCELLANEOUS FLASHING INSTALLATION

- A. Equipment Support Flashing:
 - 1. Coordinate installation of equipment support flashing with installation of roofing and equipment.
 - 2. Weld or seal flashing with elastomeric sealant to equipment support member.
- B. Overhead-Piping Safety Pans:
 - 1. Suspend pans from structure above, independent of other overhead items such as equipment, piping, and conduit, unless otherwise indicated on Drawings.
 - 2. Pipe and install drain line to plumbing waste or drainage system.

3.9 ERECTION TOLERANCES

- A. Installation Tolerances: Shim and align sheet metal flashing and trim within installed tolerance of 1/4 inch in 20 feet on slope and location lines indicated on Drawings and within 1/8 inch offset of adjoining faces and of alignment of matching profiles.
- B. Installation Tolerances: Shim and align sheet metal flashing and trim within installed tolerances specified in MCA's "Guide Specification for Residential Metal Roofing."

3.10 CLEANING

- A. Clean exposed metal surfaces of substances that interfere with uniform oxidation and weathering.
- B. Clean and neutralize flux materials. Clean off excess solder.
- C. Clean off excess sealants.

3.11 PROTECTION

- A. Remove temporary protective coverings and strippable films as sheet metal flashing and trim are installed unless otherwise indicated in manufacturer's written installation instructions.
- B. On completion of sheet metal flashing and trim installation, remove unused materials and clean finished surfaces as recommended in writing by sheet metal flashing and trim manufacturer.
- C. Maintain sheet metal flashing and trim in clean condition during construction.
- D. Replace sheet metal flashing and trim that have been damaged or that have deteriorated beyond successful repair by finish touchup or similar minor repair procedures, as determined by Architect.

END OF SECTION 076200

SECTION 076500
FLEXIBLE FLASHING

PART 1 - GENERAL

1.1 SUMMARY

- A. Section Includes:
 - 1. Self-adhered flexible flashing.
 - 2. Fluid-applied flexible flashing.

1.2 ACTION SUBMITTALS

- A. Product Data: For each type of product.

1.3 INFORMATIONAL SUBMITTALS

- A. Evaluation Reports: For water-resistive barrier and flexible flashing, from ICC-ES.

1.4 QUALITY ASSURANCE

- A. Fire-Test-Response Characteristics: For assemblies with fire-resistance ratings, provide materials and construction identical to those of assemblies tested for fire resistance per ASTM E119 by testing and inspecting agency acceptable to authorities having jurisdiction.

1.5 WARRANTY

- A. Manufacturer's Product Warranty: To repair or replace weather barrier product that fails in materials within specified warranty period.
 - 1. Warranty Period: 10 years from date of Substantial Completion.

PART 2 - PRODUCTS

2.1 SELF-ADHERED FLEXIBLE FLASHING

- A. Elastomeric Neoprene Flashing (SA.FLSHG-1): Heavy-duty, non-staining, uncured neoprene flashing and reinforcing sheet:
 - 1. Products: Subject to compliance with requirements, provide one of the following:
 - a. American Hydrotech, Inc.: Flex Flash UN.
 - b. Carlisle Coatings & Waterproofing Inc.: CCW Uncured Neoprene Flashing.
 - c. CETCO – Building Materials Group: N-Flash.
 - d. Henry Company: Neoflash Uncured Neoprene Flashing Sheet
 - e. Tremco Incorporated: Elastomeric Sheeting.
 - f. Approved substitution.
 - 2. Thickness: Minimum 60 mils.
 - 3. Tensile Strength: 1,300 psi minimum; ASTM D412, Die C.
 - 4. Elongation: 260 percent minimum; ASTM D412.
 - 5. Tear Resistance: 125 psi minimum; ASTM D624, Die C.
 - 6. Brittleness: Does not break at minus 30 deg F; ASTM D2137.
 - 7. Application: For use with hot, fluid-applied rubberized asphalt waterproofing and where indicated.

2.2 FLUID-APPLIED FLEXIBLE FLASHING

- A. Resin Flashing System (FA.FLSHG-1): Fully-reinforced, liquid-applied, catalyzed polymethyl methacrylate (PMMA) primer, multi-component flashing system consisting of a primer, basecoat, and topcoat combined with a non-woven polyester fleece installed over a prepared or primed substrate.
- a. American Hydrotech, Inc.: Hydroseal Flashing Resin.
 - b. CETCO – Building Materials Group: Cetguard Flashing.
 - c. Henry Company: Pumadeq Flex 31MV.
 - d. Siplast, Inc.: Parapro 123 Flashing System.
 - e. Soprema, Inc.: ALSAN RS 230 FLASH.
 - f. Approved substitution.
2. Performance Criteria:
- a. VOC Content: 4.2 g/L.
 - b. Solids Content by Volume: 100 percent.
 - c. Minimum Thickness: 75 mils but no less than manufacturer's recommended thickness.
 - d. Tensile Strength: ASTM D412; minimum 60 psi.
 - e. Elongation: ASTM D412; minimum 30 percent.
 - f. Shore A Hardness: ASTM D2240; minimum 35.
 - g. Static Puncture Resistance: ASTM D5602; minimum 30 lbf.
 - h. Vapor Permeance: ASTM E96, Water Method; 0.3 perms.
 - i. Water Absorption: ASTM D471; maximum 1.5 percent.
- B. Elastomeric Flashing (FA.FLSHG-2): Roller-applied, single-component, silyl-terminated- polyether (STPE) flashing material.
1. Products: Subject to compliance with requirements, provide one of the following:
 - a. DuPont Safety & Construction: Tyvek Fluid Applied Flashing and Joint Compound+.
 - b. Henry Company: Air-Bloc LF Liquid-Applied Flashing.
 - c. Polyguard Products, Inc.: Airllok Flash-N-Roll.
 - d. VaproShield LLC: VaproLiqui-Flash.
 - e. W.R. Meadows, Inc.: Air-Shield Liquid Flashing.
 - f. Approved substitution.
 2. Performance Criteria:
 - a. VOC Content: Maximum 30 g/L.
 - b. Solids Content by Volume: 95 percent.
 - c. Minimum Thickness: Minimum 15 mils but not less than manufacturer's recommended thickness.
 - d. Tensile Strength: ASTM D412; minimum 100 psi.
 - e. Elongation: ASTM D412; minimum 150 percent.
 - f. Shore A Hardness:
 - 1) Tested according to ASTM D2240: Minimum 35.
 - 2) Tested according to ASTM C661; minimum 30.
 - g. Water-Vapor Permeance: ASTM E96, Procedure B; Water Method: Not less than 9 perms at 12 mil thickness.
 3. Applications: Rough opening interface with air barrier and water resistive barrier systems

2.3 ACCESSORIES

- A. Primer for Flexible Flashing: Product recommended in writing by flexible flashing manufacturer for substrate.
- B. Joint Reinforcing Strip: Manufacturer's recommended woven polyester or fiberglass mesh.
1. Minimum Thickness: 30 mils.
- C. Nails and Staples: Product recommended in writing by flexible flashing manufacturer and complying with ASTM F1667.

PART 3 - EXECUTION

3.1 INSTALLATION OF FLEXIBLE FLASHING

- A. Apply flexible flashing where indicated to comply with manufacturer's written instructions.
 - 1. Prime substrates as recommended by flashing manufacturer.
 - 2. Lap seams and junctures with other materials at least 4 inches except that at flashing flanges of other construction, laps need not exceed flange width.
 - 3. Lap flashing over water-resistive barrier at bottom and sides of openings.
 - 4. Lap water-resistive barrier over flashing at heads of openings.
 - 5. After flashing has been applied, roll surfaces with a hard rubber or metal roller to ensure that flashing is completely adhered to substrates.

END OF SECTION 076500

SECTION 078400
FIRESTOPPING

PART 1 - GENERAL

1.1 SUMMARY

A. Section Includes:

1. Penetrations in fire-resistance-rated walls, horizontal assemblies, smoke barriers, and fire-resistance-rated shaft enclosures.
2. Joints in or between fire-resistance-rated walls and smoke barriers.

1.2 ADMINISTRATIVE REQUIREMENTS

A. Coordination:

1. Coordinate construction of joints to ensure that penetration and joint firestopping are installed according to specified requirements.
2. Coordinate sizing of joints to accommodate penetration and joint firestopping.
3. Coordinate with mechanical and electrical for openings and penetrations required to be sealed.
4. Notify Owner's testing agency a minimum of 7 days prior to penetration and joint firestopping installations; confirm dates and times on day preceding each series of installations.

B. Preinstallation Meetings: Conduct meeting at Project site.

1. Meeting Time: Schedule meeting a minimum of 2 weeks prior to beginning Work of this Section and related Work.
2. Before installation of fire-rated assemblies and penetrating items, review penetration and joint firestopping systems and examine procedures for ensuring quality of installed systems. Require representatives of each entity directly involved with firestopping to attend, including the following:
 - a. Owner, Architect, Contractor, and Contractor's Superintendent.
 - b. Independent testing agency responsible for joint firestopping system.
 - c. Joint firestopping manufacturer's service representative.
 - d. Joint firestopping Installer.
 - e. Fire-resistance-rated masonry Installer.
 - f. Fire-resistance-rated gypsum board assembly Installer.
 - g. Mechanical piping Installer.
 - h. HVAC ductwork Installer.
 - i. Electrical wireway Installer.
 - j. Other entities directly affecting Work of this Section.
3. Review inspection and testing and inspecting agency procedures for field quality control, penetration and joint firestop system installation, and coordination of penetrating item configurations with available rated firestop system assemblies.

1.3 ACTION SUBMITTALS

A. Product Data: For each type of product.

B. Sustainable Design Submittals:

1. Product Data: For sealants, indicating VOC content.
2. Laboratory Test Reports: For sealants, indicating compliance with requirements for low-emitting materials.
3. Environmental Product Declaration (EPD): For each product.
4. Health Product Declaration (HPD): For each product.

- C. Product Schedule: For each penetration and joint firestopping system. Include location, illustration of firestopping system, and design designation of qualified testing and inspecting agency.
 - 1. Engineering Judgments: Where Project conditions require modification to a qualified testing and inspecting agency's illustration for a particular firestopping condition, submit illustration, with modifications marked, approved by firestopping manufacturer's fire-protection engineer as an engineering judgment or equivalent fire-resistance-rated assembly. Obtain approval of authorities having jurisdiction prior to submittal.
- 1.4 INFORMATIONAL SUBMITTALS
- A. Qualification Data: For Installer. Include date and location of training.
 - B. Product Test Reports: For each penetration and joint firestopping system, for tests performed by a qualified testing agency.
- 1.5 CLOSEOUT SUBMITTALS
- A. Installer Certificates: From Installer indicating that penetration and joint firestopping systems have been installed in compliance with specified requirements and manufacturers' written instructions.
- 1.6 QUALITY ASSURANCE
- A. Manufacturer Qualifications: Company with a minimum of 10 years of experience specializing in manufacturing products specified in this Section.
 - B. Installer Qualifications: A firm with a minimum of 3 years of experience in installing penetration and joint firestopping similar in material, design, and extent to that indicated for this Project, with a minimum of 5 projects in which work has resulted in construction with a record of successful performance, in addition to having the following:
 - 1. Qualified to perform both penetration and joint firestopping work.
 - 2. Necessary experience, staff, and training to install manufacturer's products according to specified requirements.
 - 3. An established management system for firestopping and trained supervisor to maintain oversight of firestopping installation.
 - 4. Trained and certified by specified penetration and joint firestopping manufacturers to install specified products and systems.
 - 5. Certified by third party attesting to its ability to select and install firestopping in accordance with Performance Criteria.
 - 6. Member of Firestop Contractors International Association (FCIA).
- 1.7 PROJECT CONDITIONS
- A. Environmental Limitations: Do not install firestopping when ambient or substrate temperatures are outside limits permitted by firestopping manufacturers or when substrates are wet because of rain, frost, condensation, or other causes.
 - B. Install and cure firestopping according to manufacturer's written instructions using natural means of ventilations or, where this is inadequate, forced-air circulation.

PART 2 - PRODUCTS

2.1 MANUFACTURERS

- A. Manufacturers: Subject to compliance with requirements, provide products by one of the following:
 - 1. 3M Fire Protection Products.
 - 2. GCP Applied Technologies Inc.
 - 3. Hilti, Inc.
 - 4. Nelson Firestop Products; an Emerson Industrial Automation company.
 - 5. RectorSeal.
- B. Source Limitations: Obtain penetration and joint firestopping systems through one source from a single manufacturer.

2.2 PERFORMANCE CRITERIA

- A. Fire-Test-Response Characteristics:
 - 1. Perform penetration and joint firestopping system tests by a qualified testing agency acceptable to authorities having jurisdiction.
 - 2. Test according to testing standards referenced in "Penetration Firestopping Systems" and "Joint Firestopping Systems" Articles. Provide rated systems complying with the following requirements:
 - a. Firestopping systems shall bear classification marking of a qualified testing agency.
 - 1) UL in its "Fire Resistance Directory."
 - 2) Intertek Group in its "Directory of Listed Building Products."
- B. Exposed Firestopping Systems:
 - 1. Surface Burning Characteristics: Class I, Class A ratings according to ASTM E84:
 - a. Flame-Spread Index: 20 or less.
 - b. Smoke-Developed Index: 450 or less.
 - 2. Verify sealants have a VOC content of 250 g/L or less.
 - 3. Verify sealants comply with testing and product requirements of California Department of Public Health's "Standard Method for the Testing and Evaluation of Volatile Organic Chemical Emissions from Indoor Sources Using Environmental Chambers."

2.3 PENETRATION FIRESTOPPING SYSTEMS

- A. Penetration Firestopping Systems: Systems that resist spread of fire, passage of smoke and other gases, and maintain original fire-resistance rating of construction penetrated. Penetration firestopping systems shall be compatible with one another, with substrates forming openings, and with penetrating items if any.
- B. Penetrations in Fire-Resistance-Rated Walls: ASTM E814 or UL 1479; penetration firestopping ratings based on testing at positive pressure differential of 0.01 inch wg.
 - 1. F-Rating: Not less than fire-resistance rating of constructions penetrated.
- C. Penetrations in Horizontal Assemblies: ASTM E814 or UL 1479; penetration firestopping ratings based on testing at a positive pressure differential of 0.01 inch wg.
 - 1. F-Rating: At least 1 hour, but not less than fire-resistance rating of constructions penetrated.
 - 2. T-Rating: At least 1 hour, but not less than fire-resistance rating of constructions penetrated except for floor penetrations within cavity of a wall.
- D. Penetrations in Smoke Barriers: UL 1479; penetration firestopping with ratings based on testing at a positive pressure differential of 0.30 inch wg.
 - 1. L-Rating: Not exceeding 5.0 cfm per square foot of penetration opening at and no more than 50 cfm cumulative total for any 100 sq. ft. at both ambient and elevated temperatures.

2.4 JOINT FIRESTOPPING SYSTEMS

- A. Joint Firestopping Systems: Systems that resist spread of fire, passage of smoke and other gases, and maintain original fire-resistance rating of assemblies in or between which joint firestopping systems are installed. Joint firestopping systems shall accommodate building movements without impairing their ability to resist passage of fire and hot gases.
- B. Joints in or Between Fire-Resistance-Rated Construction: Joint firestopping systems with ratings determined according to ASTM E1966 or UL 2079:
 - 1. Fire-Resistance Rating: Equal to or exceeding fire-resistance rating of wall, floor, or roof in or between which it is installed.
- C. Joints in Smoke Barriers: Joint firestopping systems with ratings determined according to UL 2079 based on testing at a positive pressure differential of 0.30 inch wg.
 - 1. L-Rating: Not exceeding 5.0 cfm/linear ft. of joint at both ambient and elevated temperatures.

2.5 ACCESSORIES

- A. Accessories: Provide components of firestopping systems that are needed to install fill materials and to maintain ratings required. Use only components specified by firestopping system manufacturer and approved by qualified testing agency for systems indicated.
 - 1. Penetration Firestopping: Provide components for each penetration firestopping system that are needed to install fill materials and to maintain ratings required. Use only those components specified by penetration firestopping system manufacturer and approved by qualified testing and inspecting agency for firestopping indicated.
 - a. Permanent forming/damming/backing materials.
 - b. Substrate primers.
 - c. Collars.
 - d. Steel sleeves.
 - 2. Joint Firestopping: Provide components of joint firestopping systems, including primers and forming materials, that are needed to install elastomeric fill materials and to maintain ratings required. Use only components specified by joint firestopping system manufacturer and approved by qualified testing agency for systems indicated.

2.6 FILL MATERIALS

- A. Cast-in-Place Firestop Devices: Factory-assembled devices for use in cast-in-place concrete floors and consisting of an outer sleeve lined with an intumescent strip, a flange attached to one end of the sleeve for fastening to concrete formwork, and a neoprene gasket.
- B. Latex Sealants: Single-component latex formulations recommended by firestopping manufacturers that do not re-emulsify after cure during exposure to moisture.
- C. Firestop Devices for Penetration Firestopping:
 - 1. Preinstalled Firestop Devices: Factory-assembled plastic sleeve lined with intumescent strip and integrated smoke seal sized to fit specific diameter of penetrant.
 - 2. Postinstalled Firestop Devices: Factory assembled metal sleeve lined with intumescent strip and integrated smoke seal sized to fit specific diameter of penetrant
 - 3. Silicone Sealants: Not acceptable.
- D. Silicone Foams: Multicomponent, silicone-based liquid elastomers that, when mixed, expand and cure in place to produce a flexible, nonshrinking foam.
- E. Re-Penetrable Cable Management Device: Factory-assembled round metal sleeve lined with multiple intumescent strips and integrated smoke seal.
- F. Putties and Pads: Wall opening protective materials for use with UL listed metallic and specified nonmetallic outlet boxes.

- G. Intumescent Composite Sheets: Rigid panels consisting of aluminum-foil-faced intumescent elastomeric sheet bonded to galvanized-steel sheet.
- H. Intumescent Putties: Nonhardening, water-resistant, intumescent putties containing no solvents or inorganic fibers.
- I. Intumescent Wrap Strips: Single-component intumescent elastomeric sheets with aluminum foil on one side.
- J. Mortars: Prepackaged dry mixes consisting of a blend of inorganic binders, hydraulic cement, fillers and lightweight aggregate formulated for mixing with water at Project site to form a nonshrinking, homogeneous mortar.
- K. Pillows/Bags: Reusable heat-expanding pillows/bags consisting of glass-fiber cloth cases filled with a combination of mineral-fiber, water-insoluble expansion agents, and fire-retardant additives. Where exposed, cover openings with steel-reinforcing wire mesh to protect pillows/bags from being easily removed.

2.7 MIXING

- A. Penetration Firestopping Materials: For those products requiring mixing before application, comply with penetration firestopping system manufacturer's written instructions for accurate proportioning of materials, water (if required), type of mixing equipment, selection of mixer speeds, mixing containers, mixing time, and other items or procedures needed to produce products of uniform quality with optimum performance characteristics for application indicated.

2.8 IDENTIFICATION

- A. Identification for Firestop Systems: Wall labels containing penetration and joint firestopping systems with legible words "FIRE AND/OR SMOKE BARRIER - PROTECT ALL OPENINGS."
 - 1. Label Material: Metal, plastic, pressure-sensitive, self-adhesive, preprinted vinyl labels, or stencils.
 - 2. Lettering: Not less than 3 inches high and with minimum 0.375-inch strokes, or as required by Authority Having Jurisdiction.
 - 3. Color: Red.
 - 4. Identify or include spaces for following information:
 - a. The words "FIRE AND/OR SMOKE BARRIER – PROTECT ALL OPENINGS", or other approved wording.
 - b. Contractor's name, address, and phone number.
 - c. Designation of applicable testing and inspecting agency.
 - d. Product manufacturer's engineered design number.
 - e. F Rating and T Rating (as applicable).
 - f. Date of installation.
 - g. Manufacturer's name.
 - h. Installer's name.
 - 5. Mounting: Permanently-attached with mechanical fasteners or self-adhering.
 - 6. Locations: At surfaces adjacent to and within 6 inches of penetration and joint edges above decorative ceilings, in concealed spaces, or other approved location so labels are visible to anyone seeking to remove or penetrate firestopping systems.
 - a. Spacing: At 15 feet from end of wall and at intervals not exceeding 30 feet measured horizontally along wall or partition.
 - b. Penetration Firestopping: Apply to surfaces on both sides of penetrated construction.

PART 3 - EXECUTION

3.1 EXAMINATION

- A. Examine substrates and conditions, with Installer present, for compliance with requirements for opening configurations, penetrating items, joint configurations, substrates, and other conditions affecting performance of Work.
- B. Proceed with installation only after unsatisfactory conditions have been corrected.

3.2 PREPARATION

- A. Surface Cleaning: Before installing firestopping systems, clean out openings and joints immediately to comply with manufacturer's written instructions and with the following requirements:
 - 1. Remove from surfaces of opening substrates and from penetrating items foreign materials that could interfere with adhesion of penetration firestopping materials.
 - 2. Clean opening substrates and penetrating items to produce clean, sound surfaces capable of developing optimum bond with penetration firestopping materials. Remove loose particles remaining from cleaning operation.
 - 3. Clean joint substrates to produce clean, sound surfaces capable of developing optimum bond with fill materials. Remove loose particles remaining from cleaning operation.
 - 4. Remove laitance and form-release agents from concrete.
- B. Prime substrates where recommended in writing by manufacturer using that manufacturer's recommended products and methods. Confine primers to areas of bond; do not allow spillage and migration onto exposed surfaces.
- C. Masking Tape: Use masking tape to prevent fill materials of firestopping from contacting adjoining surfaces that will remain exposed on completion of Work and that would otherwise be permanently stained or damaged by such contact or by cleaning methods used to remove stains. Remove tape as soon as possible without disturbing firestopping's seal with substrates.

3.3 INSTALLATION

- A. General: Install penetration and joint firestopping systems to comply with manufacturer's written installation instructions and published drawings for products and applications.
- B. Install forming materials and other accessories of types required to support elastomeric fill materials during their application and in position needed to produce cross-sectional shapes and depths required to achieve fire ratings.
 - 1. After installing elastomeric fill materials and allowing them to fully cure, remove combustible forming materials and other accessories not indicated as permanent components of firestopping systems.
- C. Install fill materials for firestopping systems by proven techniques to produce the following results:
 - 1. Fill voids and cavities formed by joints, openings, forming materials, accessories, and penetrating items to achieve required fire-resistance ratings indicated.
 - 2. Apply fill materials so they contact and adhere to substrates formed by joints, openings, and penetrating items.
 - 3. For fill materials that will remain exposed after completing Work, finish to produce smooth, uniform surfaces that are flush with adjoining finishes.

3.4 FIELD QUALITY CONTROL

- A. Owner will engage a qualified testing agency to perform tests and inspections according to ASTM E2174 and ASTM E2393.
- B. Where deficiencies are found or firestopping is damaged or removed because of testing, repair or replace penetration and joint firestopping to comply with requirements.
- C. Proceed with enclosing firestopping with other construction only after inspection reports are issued and installations comply with requirements.

3.5 CLEANING AND PROTECTION

- A. Clean off excess fill materials adjacent to openings as Work progresses by methods and with cleaning materials that are approved in writing by firestopping manufacturers and that do not damage materials in which openings occur.
- B. Provide final protection and maintain conditions during and after installation that ensure that penetration and joint firestopping is without damage or deterioration at time of Substantial Completion. If, despite such protection, damage or deterioration occurs, immediately cut out and remove damaged or deteriorated firestopping and install new materials to produce systems complying with specified requirements.

END OF SECTION 078400

SECTION 079200
JOINT SEALANTS

PART 1 - GENERAL

1.1 SUMMARY

- A. Section Includes:
 - 1. Elastomeric joint sealants.
 - 2. Immersible joint sealants.
 - 3. Mildew-resistant joint sealants.
 - 4. Joint sealant backing.

1.2 ADMINISTRATIVE REQUIREMENTS

- A. Preinstallation Meetings: Conduct meeting at Project site.

1.3 ACTION SUBMITTALS

- A. Product Data: For each joint-sealant product.
- B. Sustainable Design Submittals:
 - 1. Environmental Product Declaration (EPD): For each product.
 - 2. Health Product Declaration (HPD): For each product.
 - 3. Product Data: For sealants, indicating VOC content.
 - 4. Laboratory Test Reports: For sealants, indicating compliance with requirements for low-emitting materials.
- C. Samples for Verification: For each kind and color of joint sealant required, provide Samples with joint sealants in 1/2 inch wide joints formed between two 6 inch long strips of material matching appearance of exposed surfaces adjacent to joint sealants.
- D. Sealant Schedule: Submit schedule of sealant applications listing joint sealants proposed for this Work and materials to which joint sealants are specified to be applied. Obtain Architect's written approval of this sealant schedule before starting Work of this Section.
 - 1. Joint-Sealant Schedule: Include the following information:
 - a. Joint-sealant application, joint location, and designation.
 - b. Joint-sealant manufacturer and product name.
 - c. Joint-sealant formulation.
 - d. Joint-sealant color.

1.4 INFORMATIONAL SUBMITTALS

- A. Qualification Data: For qualified testing agency.
- B. Product Test Reports: For each kind of joint sealant, for tests performed by manufacturer and witnessed by qualified testing agency. Include the following information for each joint sealant and substrate material to be tested:
 - 1. Joint-sealant location and designation.
 - 2. Manufacturer and product name.
 - 3. Type of substrate material.
 - 4. Proposed test.
 - 5. Number of samples required.

- C. Preconstruction Laboratory Test Reports: From sealant manufacturer, indicating the following:
 - 1. Materials forming joint substrates and joint-sealant backings have been tested for compatibility and adhesion with joint sealants.
 - 2. Interpretation of test results and written recommendations for primers and substrate preparation are needed for adhesion.
- D. Preconstruction Field-Adhesion-Test Reports: Indicate which sealants and joint preparation methods resulted in optimum adhesion to joint substrates based on testing specified in "Preconstruction Testing" Article.
- E. Sealant, Waterproofing, and Restoration Institute (SWRI) Validation Certificate: For each sealant specified to be validated by SWRI's Sealant Validation Program.
- F. Sample Warranties: For special warranties.

1.5 QUALITY ASSURANCE

- A. Installer Qualifications: An entity that employs installers who are trained and approved by sealant manufacturer with a minimum 5 years of documented experience performing work similar in scale and scope to this Project.
 - 1. Single Source Responsibility: Provide field-installation of exterior joint sealers specified in this Section under responsibility of a single installer.
- B. Testing Agency Qualifications: Qualified according to ASTM C1021 to conduct testing indicated.
- C. Product Testing: Test joint sealants using a qualified testing agency.
 - 1. Test according to SWRI's Sealant Validation Program for compliance with requirements specified by reference to ASTM C920 for adhesion and cohesion under cyclic movement, adhesion-in-peel, and indentation hardness.
- D. Mockups: Build mockups in compliance with Section 014339 – Mockups and to verify selections made under Sample submittals, to demonstrate aesthetic effects, and to set quality standards for materials and execution.
 - 1. Conduct mockups of joint sealing systems specified in this Section as part of system mockups as specified by related Sections for purpose of verifying visual appearance, water and air infiltration testing, conducting pull tests to determine correct use of cleaning and primers, and to aid in determining general adequacy of system design.
 - 2. Include concrete systems, masonry mockup walls, wall cladding, roofing and waterproofing systems, and window systems.
 - 3. Include system components including backing materials and bond breakers.
 - 4. Verify need for primers and other preinstallation preparation for each surface.
 - 5. Inspect mockups after 14 days and perform pull test under supervision of manufacturer's representative to determine suitability and primer requirements.
 - 6. Make adjustments as needed for acceptance conforming to manufacturer's instructions and provisions of Contract Documents.
 - 7. Protect accepted mockup as quality standard for Work of this Section.

1.6 PRECONSTRUCTION TESTING

- A. Preconstruction Laboratory Testing: Submit to joint-sealant manufacturers, for testing indicated below, samples of materials that will contact or affect joint sealants.
 - 1. Adhesion Testing: Use ASTM C794 to determine whether priming and other specific joint preparation techniques are required to obtain rapid, optimum adhesion of joint sealants to joint substrates.
 - 2. Compatibility Testing: Use ASTM C1087 to determine sealant compatibility when in contact with glazing and gasket materials.

3. Stain Testing: Use ASTM C1248 to determine stain potential of sealant when in contact with masonry substrates.
4. Submit manufacturer's recommended number of pieces of each type of material, including joint substrates, joint-sealant backings, and miscellaneous materials.
5. Schedule sufficient time for testing and analyzing results to prevent delaying Work.
6. For materials failing tests, obtain joint-sealant manufacturer's written instructions for corrective measures, including use of specially formulated primers.
7. Testing will not be required if joint-sealant manufacturers submit data that are based on previous testing, not older than 24 months, of sealant products for adhesion to, staining of, and compatibility with joint substrates and other materials matching those submitted.

B. Preconstruction Field-Adhesion Testing: Before installing sealants, field test their adhesion to Project joint substrates as follows:

1. Locate test joints where indicated on Project or, if not indicated, as directed by Architect.
2. Conduct field tests for each kind of sealant and joint substrate.
3. Notify Architect 7 days in advance of dates and times when test joints will be erected.
4. Adhesion Testing: Use ASTM C794 to determine whether priming and other specific joint preparation techniques are required to obtain rapid, optimum adhesion of joint sealants to joint substrates.
5. Compatibility Testing: Use ASTM C1087 to determine sealant compatibility when in contact with glazing and gasket materials.
1. Arrange for tests to take place with joint-sealant manufacturer's technical representative present.
 - a. Test Method: Test joint sealants per Method A, Field-Applied Sealant Joint Hand Pull Tab, in Appendix X1 in ASTM C1193 or Method A, Tail Procedure, in ASTM C1521.
 - 1) For joints with dissimilar substrates, verify adhesion to each substrate separately: extend cut along 1 side, verifying adhesion to opposite side. Repeat procedure for opposite side.
 2. Report whether sealant failed to adhere to joint substrates or tore cohesively. Include data on pull distance used to test each kind of product and joint substrate. For sealants that fail adhesively, retest until satisfactory adhesion is obtained.
 3. Evaluation of Preconstruction Field-Adhesion-Test Results: Sealants not evidencing adhesive failure from testing, in absence of other indications of noncompliance with requirements, will be considered satisfactory. Do not use sealants that fail to adhere to joint substrates during testing.

1.7 FIELD CONDITIONS

A. Do not proceed with installation of joint sealants under the following conditions:

1. When ambient and substrate temperature conditions are outside limits permitted by joint-sealant manufacturer or are below 40 deg F.
2. When joint substrates are wet.
3. Where joint widths are less than those allowed by joint-sealant manufacturer for applications indicated.
4. Where contaminants capable of interfering with adhesion have not yet been removed from joint substrates.

1.8 WARRANTY

A. Special Installer's Warranty: Installer agrees to repair or replace joint sealants that do not comply with performance and other requirements specified in this Section within specified warranty period.

1. Warranty Period: 5 years from date of Substantial Completion.

- B. Special Manufacturer's Warranty: Manufacturer agrees to furnish joint sealants to repair or replace those joint sealants that do not comply with performance and other requirements specified in this Section within specified warranty period.
 - 1. Warranty Period: 5 years [**20 years**] from date of Substantial Completion.
- C. Special warranties specified in this Article exclude deterioration or failure of elastomeric joint sealants from the following:
 - 1. Movement of structure caused by stresses on sealant exceeding sealant manufacturer's written specifications for sealant elongation and compression.
 - 2. Disintegration of joint substrates from natural causes exceeding design specifications.
 - 3. Mechanical damage caused by individuals, tools, or other outside agents.
 - 4. Changes in sealant appearance caused by accumulation of dirt or other atmospheric contaminants.

PART 2 - PRODUCTS

2.1 JOINT SEALANTS, GENERAL

- A. Provide joint sealants, backings, and other related materials that are compatible with one another and with joint substrates under conditions of service and application, as demonstrated by joint-sealant manufacturer, based on testing and field experience.
 - 1. Verify sealants have a VOC content of 250 g/L or less.
 - 2. Verify sealants comply with testing and product requirements of California Department of Public Health's "Standard Method for the Testing and Evaluation of Volatile Organic Chemical Emissions from Indoor Sources Using Environmental Chambers."
- B. Colors of Exposed Joint Sealants: As selected by Architect from manufacturer's full range.
 - 1. Where color is indicated to "match adjacent substrates" or "match existing," provide either manufacturer's standard color if matching color is available, or, if not available, provide field-tintable custom color.

2.2 JOINT SEALANTS TYPES

- A. Silicone (Type S1): Nonstaining, single-component, nonsag, nontraffic-use, neutral-curing silicone joint sealant; ASTM C 920, Type S, Grade NS, Class 50, Use NT.
 - 1. Products: Subject to compliance with requirements, provide one of the following:
 - a. Dow Chemical Company: Dowsil 795.
 - b. Momentive Performance Materials, Inc.: GE SCS9000 Silpruf NB.
 - c. Pecora Corporation: 895NST.
 - d. Sika Corporation: Sikasil WS-295.
 - e. Tremco Incorporated: Spectrem 2.
 - f. Approved substitution.
- B. Silicone, Mildew Resistant, Acid Curing (Type S2): Mildew-resistant, single-component, nonsag, nontraffic-use, acid-curing silicone joint sealant; ASTM C920, Type S, Grade NS, Class 25, Use NT; Formulated for prolonged exposure to humidity with fungicide to prevent mold and mildew growth.
 - 1. Products: Subject to compliance with requirements, provide one of the following:
 - a. Dow Chemical Company: Dowsil 786.
 - b. ITW Polymers Sealants North America: Acryl-R SM8500.
 - c. Momentive Performance Materials, Inc.: GE SCS1700 Sanitary.
 - d. Pecora Corporation: 898NST Sanitary Silicone.
 - e. Sika Corporation: Sikasil-GP.
 - f. Tremco Incorporated: Tremsil 200.
 - g. Approved substitution.
 - 2. Color: Clear unless indicated otherwise.

- C. Silicone (Type S4): Neutral-curing silicone glazing sealant complying with ASTM C920, Type S, Grade NS, Class 100/50, Use NT.
1. Products: Subject to compliance with requirements, provide one of the following:
 - a. Dow Chemical Company: Dowsil 790 Silicone Building Sealant.
 - b. Momentive Performance Materials, Inc.: GE SCS2700 SilPruf LM.
 - c. Pecora Corporation: 890NST.
 - d. Sika Corporation: Sikasil WS-290.
 - e. Tremco Incorporated: Spectrem 1.
 - f. Approved substitution.
- D. Silicone (Type S5): Neutral-curing, single-component, nonsag, nontraffic-use sealant complying with ASTM C920, Type S, Grade NS, Class 25, Use NT.
1. Products: Subject to compliance with requirements, provide one of the following:
 - a. Dow Chemical Company: Dowsil 758 Silicone Weather Barrier Sealant.
 - b. ITW Polymers Sealants North America, Inc.: Permathane SM5731.
 - c. Momentive Performance Materials, Inc.: GE SSG4000 UltraGlaze or GE SSG4000AC UltraGlaze.
 - d. Pecora Corporation: 896 ABV Silicone.
 - e. Polymeric Systems, Inc.: PSI-613.
 - f. Sika Corporation: Sikasil-N Plus US.
 - g. Tremco Incorporated: S Proglaze SSG.
 - h. VaproShield LLC: VaproBond.
 - i. Approved substitution.
- E. STPE (Type STPE1): Single-component, nonsag, nontraffic-use, silyl-terminated polyether joint sealant; ASTM C920, Type S, Grade NS, Class 50, Use NT.
1. Products: Subject to compliance with requirements, provide one of the following:
 - a. BASF Construction Systems: MasterSeal NP 150.
 - b. Polymeric Systems, Inc.: Flexiprene 1000.
 - c. Sherwin-Williams Company (The): Loxon H1.
 - d. Sika Corporation: Sikaflex-150 AM 50.
 - e. Approved substitution.
- F. STPE (Type STPE3): Single-component, nonsag, nontraffic-use, silyl-terminated polyether joint sealant; ASTM C920, Type S, Grade NS, Class 25, Use NT.
- a. Products: Subject to compliance with requirements, provide one of the following:
 - b. BASF Construction Systems: MasterSeal NP 100.
 - c. Henkel Corporation: OSI QUAD Window, Door & Siding Sealant
 - d. ITW Polymers Sealants North America: Permathane SM2100.
 - e. Polymeric Systems, Inc.: Sili-Thane 803.
 - f. Tremco Incorporated: Dymonic FC.
 - g. Approved substitution.
- G. Urethane (Type U1): Single-component, pourable, traffic- and nontraffic-use, urethane joint sealant; ASTM C920, Type S, Grade P, Class 25, Uses T and NT.
1. Products: Subject to compliance with requirements, provide one of the following:
 - a. BASF Construction Systems: MasterSeal SL 1.
 - b. Pecora Corporation: Urexpam NR-201.
 - c. Sherwin-Williams Company (The): Loxon SL1.
 - d. Sika Corporation: Sikaflex 1c SL.
 - e. Tremco Incorporated: Vulkem 45SSL.
 - f. W. R. Meadows, Inc.: Pourthane SL.
 - g. Approved substitution.

- H. Urethane (Type U2): Multicomponent, pourable, traffic- and nontraffic-use, urethane joint sealant; ASTM C920, Type M, Grade P, Class 25, Uses T, NT, M, A, and I.
 - 1. Products: Subject to compliance with requirements, provide one of the following:
 - a. BASF Construction Systems: MasterSeal SL 2.
 - b. LymTal International Inc.: Iso-Flex 880 GB.
 - c. Pecora Corporation: Dynatrol II SG or Urexpan NR-200.
 - d. Sherwin-Williams Company (The): Loxon SL2.
 - e. Sika Corporation: Sikaflex 2c SL.
 - f. Tremco Incorporated: THC 901.
 - g. Approved substitution.
- I. Urethane (Type U3): Multicomponent, nonsag, traffic- and nontraffic-use, urethane joint sealant; ASTM C920, Type M, Grade NS, Class 25, Uses T and NT.
 - 1. Products: Subject to compliance with requirements, provide one of the following:
 - a. BASF Construction Systems: MasterSeal NP 2.
 - b. Pacific Polymers International, Inc.: Elasto-Thane 227.
 - c. Sherwin-Williams Company (The): Loxon NS2.
 - d. Sika Corporation: Sikaflex 2c NS.
 - e. Tremco Incorporated: Dymeric 240 FC NP 2.
 - f. Approved substitution.
- J. Urethane, Textured (Type U4): Single-component, nonsag, nontraffic-use, urethane joint sealant; ASTM C920, Type S, Grade NS, Class 25, Use NT, G, M, A, and O.
 - 1. Products: Subject to compliance with requirements, provide one of the following:
 - a. BASF Construction Systems: MasterSeal TX1.
 - b. ITW Polymers Sealants North America: Permthane SM7108.
 - c. Pecora Corporation: Dynatrol I-XL.
 - d. Polymeric Systems, Inc.: Flexiprene 1000.
 - e. Sherwin-Williams Company (The): Loxon TX.
 - f. Sika Corporation: Sikaflex Textured Sealant.
 - g. Tremco Incorporated: Dymonic.
 - h. Approved substitution.
 - 2. Application: For exterior horizontal pedestrian and traffic conditions.
- K. Acrylic Latex (Type AL1): Acrylic latex or siliconized acrylic latex, paintable after cure, ASTM C834, Type OP, Grade NF.
 - 1. Products: Subject to compliance with requirements, provide one of the following:
 - a. BASF Construction Systems: MasterSeal NP 520.
 - b. ITW Polymers Sealants North America: Acryl-R SM8500.
 - c. Pecora Corporation: AC-20+ Silicone.
 - d. Sherwin-Williams Company (The): PowerHouse Siliconized Acrylic latex Caulk.
 - e. Tremco Incorporated: Tremflex 834.
 - f. Approved substitution.
 - 2. Color: Match adjacent finish surfaces.
- L. Butyl-Rubber-Based Joint Sealant (Type BR1): Single, component, non-skinning, butyl-based, solvent release sealant; ASTM C1311, Class 12-1/2.
 - 1. Products: Subject to compliance with requirements, provide one of the following:
 - a. Pecora Corporation: BC-158.
 - b. Premier Building Solutions: XtraBond 1500.
 - c. Tremco Incorporated: Tremco Butyl Sealant.
 - d. Approved substitution.
 - 2. Performance Requirements:
 - a. Movement Capability: Plus/minus 12-1/2 percent.
 - b. Service Temperature Range: 13 to 180 deg F.
 - c. Shore A Hardness Range: 10 to 30.

2.3 JOINT-SEALANT BACKING

- A. Joint Sealant Backing Material, General: Nonstaining; compatible with joint substrates, sealants, primers, and other joint fillers; as approved in writing by joint-sealant manufacturer, for joint applications indicated based on field experience and laboratory testing.
- B. Cylindrical Sealant Backings: ASTM C1330; Type C (closed-cell material with a surface skin), Type O (open-cell material), Type B (bicellular material with a surface skin), or any of the preceding types, as approved in writing by joint-sealant manufacturer for joint application indicated, and of size and density to control sealant depth and otherwise contribute to producing optimum sealant performance.
- C. Cylindrical Sealant Backings: ASTM C1330; any of the following types, as approved in writing by joint-sealant manufacturer for joint application indicated, and of size and density to control sealant depth and otherwise contribute to producing optimum sealant performance.
 - 1. Type B (bicellular material with surface skin):
 - 2. Type C (closed-cell material with a surface skin):
 - 3. Type O (open-cell material):
- D. Bond-Breaker Tape: Polyethylene tape or other plastic tape recommended by sealant manufacturer for preventing sealant from adhering to rigid, inflexible joint-filler materials or joint surfaces at back of joint. Provide self-adhesive tape where applicable.

2.4 MISCELLANEOUS MATERIALS

- A. Primer: Material recommended by joint-sealant manufacturer where required for adhesion of sealant to joint substrates indicated, as determined from preconstruction joint-sealant-substrate tests and field tests.
- B. Cleaners for Nonporous Surfaces: Chemical cleaners acceptable to manufacturers of sealants and sealant backing materials, free of oily residues or other substances capable of staining or harming joint substrates and adjacent nonporous surfaces in any way, and formulated to promote optimum adhesion of sealants to joint substrates.
- C. Masking Tape: Nonstaining, nonabsorbent material compatible with joint sealants and surfaces adjacent to joints.

PART 3 - EXECUTION

3.1 EXAMINATION

- A. Examine joints indicated to receive joint sealants, with Installer present, for compliance with requirements for joint configuration, installation tolerances, and other conditions affecting joint-sealant performance.
- B. Proceed with installation only after unsatisfactory conditions have been corrected.

3.2 PREPARATION

- A. Surface Cleaning of Joints: Clean out joints immediately before installing joint sealants to comply with joint-sealant manufacturer's written instructions and the following requirements:
 - 1. Remove foreign material from joint substrates that could interfere with adhesion of joint sealant, including dust, paints (except for permanent, protective coatings tested and approved for sealant adhesion and compatibility by sealant manufacturer), existing joint sealants, oil, grease, waterproofing, water repellents, water, surface dirt, and frost.

2. Clean porous joint substrate surfaces by brushing, grinding, mechanical abrading, or a combination of these methods to produce a clean, sound substrate capable of developing optimum bond with joint sealants. Remove loose particles remaining after cleaning operations above by vacuuming or blowing out joints with oil-free compressed air. Porous joint substrates include the following:
 - a. Concrete.
 - b. Masonry.
 - c. Unglazed surfaces of ceramic tile.
 3. Remove laitance and form-release agents from concrete.
 4. Clean nonporous joint substrate surfaces with chemical cleaners or other means that do not stain, harm substrates, or leave residues capable of interfering with adhesion of joint sealants. Nonporous joint substrates include the following:
 - a. Metal.
 - b. Glass.
 - c. Glazed surfaces of ceramic tile.
- B. Joint Priming: Prime joint substrates where recommended by joint-sealant manufacturer or as indicated by preconstruction joint-sealant-substrate tests or prior experience. Apply primer to comply with joint-sealant manufacturer's written instructions. Confine primers to areas of joint-sealant bond; do not allow spillage or migration onto adjoining surfaces.
- C. Masking Tape: Use masking tape where required to prevent contact of sealant or primer with adjoining surfaces that otherwise would be permanently stained or damaged by such contact or by cleaning methods required to remove sealant smears. Remove tape immediately after tooling without disturbing joint seal.

3.3 INSTALLATION

- A. General: Comply with joint-sealant manufacturer's written installation instructions for products and applications indicated, unless more stringent requirements apply.
- B. Sealant Installation Standard: Comply with recommendations in ASTM C1193 for use of joint sealants as applicable to materials, applications, and conditions indicated.
- C. Install sealant backings of kind indicated to support sealants during application and at position required to produce cross-sectional shapes and depths of installed sealants relative to joint widths that allow optimum sealant movement capability.
 1. Do not leave gaps between ends of sealant backings.
 2. Do not stretch, twist, puncture, or tear sealant backings.
 3. Remove absorbent sealant backings that have become wet before sealant application and replace them with dry materials.
- D. Install bond-breaker tape behind sealants where sealant backings are not used between sealants and backs of joints.
- E. Install sealants using proven techniques that comply with the following and at same time backings are installed:
 1. Place sealants so they directly contact and fully wet joint substrates.
 2. Completely fill recesses in each joint configuration.
 3. Produce uniform, cross-sectional shapes and depths relative to joint widths that allow optimum sealant movement capability.
- F. Tooling of Nonsag Sealants: Immediately after sealant application and before skinning or curing begins, tool sealants per requirements specified in subparagraphs below to form smooth, uniform beads of configuration indicated; to eliminate air pockets; and to ensure contact and adhesion of sealant with sides of joint.
 1. Remove excess sealant from surfaces adjacent to joints.

2. Use tooling agents that are approved in writing by sealant manufacturer and that do not discolor sealants or adjacent surfaces.
3. Provide concave joint profile per Figure 8A in ASTM C1193, unless otherwise indicated.

3.4 FIELD QUALITY CONTROL

- A. Field-Adhesion Testing: Owner will engage qualified testing agency to field test joint-sealant adhesion to joint substrates as follows:
 1. Extent of Testing: Test completed and cured sealant joints as follows:
 - a. Perform 10 tests for the first 1,000 feet of joint length for each kind of sealant and joint substrate.
 - b. Perform 1 test for each 1,000 feet of joint length thereafter or 1 test per each floor per elevation.
 2. Test Method: Test joint sealants per Method A, Field-Applied Sealant Joint Hand Pull Tab, in Appendix X1 in ASTM C1193 or Method A, Tail Procedure, in ASTM C1521.
 - a. For joints with dissimilar substrates, verify adhesion to each substrate separately: extend cut along one side, verifying adhesion to opposite side. Repeat procedure for opposite side.
 3. Inspect tested joints and report on the following:
 - a. Whether sealants filled joint cavities and are free of voids.
 - b. Whether sealant dimensions and configurations comply with specified requirements.
 - c. Whether sealants in joints connected to pulled-out portion failed to adhere to joint substrates or tore cohesively. Include data on pull distance used to test each kind of product and joint substrate. Compare these results to determine if adhesion passes sealant manufacturer's field-adhesion hand-pull test criteria.
 4. Record test results in a field-adhesion-test log. Include dates when sealants were installed, names of persons who installed sealants, test dates, test locations, whether joints were primed, adhesion results and percent elongations, sealant fill, sealant configuration, and sealant dimensions.
- B. Repair sealants pulled from test area by applying new sealants following same procedures used originally to seal joints. Ensure that original sealant surfaces are clean and that new sealant contacts original sealant.
- C. Evaluation of Field-Adhesion Test Results: Sealants not evidencing adhesive failure from testing or noncompliance with other indicated requirements will be considered satisfactory. Remove sealants that fail to adhere to joint substrates during testing or to comply with other requirements. Retest failed applications until test results prove sealants comply with indicated requirements.

3.5 CLEANING

- A. Clean off excess sealant or sealant smears adjacent to joints as Work progresses by methods and with cleaning materials approved in writing by manufacturers of joint sealants and of products in which joints occur.

3.6 PROTECTION

- A. Protect joint sealants during and after curing period from contact with contaminating substances and from damage resulting from construction operations or other causes so sealants are without deterioration or damage at time of Substantial Completion. If, despite such protection, damage or deterioration occurs, cut out and remove damaged or deteriorated joint sealants immediately so installations with repaired areas are indistinguishable from original Work.

3.7 EXTERIOR JOINT-SEALANT SCHEDULE

- A. Joint-Sealant Application: Exterior joints in vertical surfaces.
 - 1. Joint-Sealant Type S1 or Type STPE1.
 - 2. Joint Locations:
 - a. Joints between concrete panels; joints between concrete panels and adjacent surfaces.
 - b. Control, expansion, and soft joints in masonry; between masonry and adjacent surfaces.
 - c. Joints between exterior metal frames and adjacent surfaces, except masonry:
 - 1) Metal to metal joints.
 - d. Exterior Joints for which no other sealant type is Indicated.
- B. Joint-Sealant Application: Exterior joints in horizontal traffic surfaces:
 - 1. Joint-Sealant Type U2.
 - 2. Joint Locations:
 - a. Control and expansion joints in concrete and asphalt paving.
 - b. Control and expansion joints for concrete sidewalks, plazas, and other types of concrete construction.
 - c. Isolation and contraction joints in cast-in-place concrete slabs.
 - d. Joints of wheel and foot traffic.
- C. Joint-Sealant Application: Exterior joints in vertical surfaces and horizontal, nontraffic surfaces:
 - 1. Joint-Sealant Type U3.
 - 2. Joint Locations:
 - a. Construction joints in cast-in-place concrete.
 - b. Control, expansion, and soft joints in unit masonry.
 - c. Joints in fiber cement siding systems.
 - d. Joints between metal panels.
 - e. Joints between different materials listed above.
 - f. Control and expansion joints in ceilings and other overhead surfaces.
 - g. Other joints as indicated Drawings.
- D. Joint-Sealant Application: Concealed mastics.
 - 1. Joint-Sealant Type B1.
 - 2. Joint Locations:
 - a. Sheet metal flashing, metal Work and other joints requiring nonhardening, nonskinning, non-drying, nonmigrating sealant.
 - b. Sealing seams of various sheet membranes, flashing, and roofing where indicated.
 - c. For compression sealing where membrane is being terminated using a compression-type seal.
 - d. Locations of concealed mastic such as aluminum thresholds, sill plates, flashings, and other locations indicated on Drawings where little or no movement is expected.

3.8 INTERIOR JOINT-SEALANT SCHEDULE

- A. Joint-Sealant Application: Mildew-resistant interior joints in vertical surfaces and horizontal, nontraffic surfaces:
 - 1. Joint-Sealant Type S2 ~~or Type STPE2~~.
 - 2. Joint Locations:
 - a. Joints between plumbing fixtures, including countertops, vanities, tubs, showers, and other locations subject to moisture.
 - b. Tile control and expansion joints where indicated.
 - c. Other joints as indicated.

- B. Joint-Sealant Application: Interior joints in horizontal traffic surfaces:
 - 1. Joint-Sealant Type U1.
 - 2. Joint Locations:
 - a. Interior horizontal traffic joints.
 - b. Paving and flooring control.
 - c. Floor expansion joints.
 - d. Other joints as indicated on Drawings.

- C. Joint-Sealant Application: Interior joints in vertical surfaces.
 - 1. Joint-Sealant Type U3.
 - 2. Joint Locations:
 - a. Perimeter joints between interior materials and frames of doors, windows, and louvers in exterior walls.

- D. Joint-Sealant Application: Interior joints in vertical surfaces and horizontal nontraffic surfaces not subject to significant movement.
 - 1. Joint-Sealant Type AL1 or Type STPE3.
 - 2. Joint Locations:
 - a. Nonmoving Interior gypsum board wall and ceiling control joints.
 - b. Perimeter joints between interior wall surfaces and frames of elevator entrances, interior doors, and interior windows.
 - c. Other joints as indicated on Drawings.

- E. Joint-Sealant Application: Acoustical Sealants.
 - 1. Joint-Sealant Type AL2.
 - 2. Joint Locations: Specified in Section 079219.

END OF SECTION 079200

SECTION 079219
ACOUSTICAL JOINT SEALANTS

PART 1 - GENERAL

1.1 SUMMARY

- A. Section Includes:
1. Acoustical joint sealants.

1.2 ACTION SUBMITTALS

- A. Product Data: For each acoustical joint sealant.
- B. Sustainable Design Submittals:
1. Environmental Product Declaration (EPD): For each product.
 2. Health Product Declaration (HPD): For each product.
 3. Product Data: For sealants, indicating VOC content.
 4. Laboratory Test Reports: For sealants, indicating compliance with requirements for low-emitting materials.
- C. Samples for Verification: For each kind and color of acoustical joint sealant required, provide Samples with joint sealants in 1/2 inchwide joints formed between two 6 inchlong strips of material matching appearance of exposed surfaces adjacent to joint sealants.
- D. Acoustical-Joint-Sealant Schedule: Include the following information:
1. Joint-sealant application, joint location, and designation.
 2. Joint-sealant manufacturer and product name.
 3. Joint-sealant formulation.
 4. Joint-sealant color.

1.3 INFORMATIONAL SUBMITTALS

- A. Product Test Reports: For each kind of acoustical joint sealant, for tests performed by a qualified testing agency or by manufacturer and witnessed by a qualified testing agency.
- B. Sample Warranties: For special warranties.

1.4 WARRANTY

- A. Special Installer's Warranty: Installer agrees to repair or replace acoustical joint sealants that do not comply with performance and other requirements specified in this Section within specified warranty period.
1. Warranty Period: 2 years from date of Substantial Completion.
- B. Special Manufacturer's Warranty: Manufacturer agrees to furnish acoustical joint sealants to repair or replace those joint sealants that do not comply with performance and other requirements specified in this Section within specified warranty period.
1. Warranty Period: 5 years from date of Substantial Completion.

PART 2 - PRODUCTS

2.1 PERFORMANCE CRITERIA

- A. Provide acoustical joint-sealant products that effectively reduce airborne sound transmission through perimeter joints and openings in building construction, as demonstrated by testing representative assemblies according to ASTM E90.
 - 1. Verify sealants have a VOC content of 250 g/L or less.
 - 2. Verify sealants comply with testing and product requirements of California Department of Public Health's "Standard Method for the Testing and Evaluation of Volatile Organic Chemical Emissions from Indoor Sources Using Environmental Chambers."

2.2 ACOUSTICAL JOINT SEALANTS

- A. Comply with requirements in Section 079200 – Joint Sealants.
- B. Acoustical Sealant for Concealed and Exposed Joints (Type AL2): Manufacturer's standard nonsag, paintable, nonstaining latex acoustical sealant complying with ASTM C834. .
 - 1. Non-Fire Rated Products: Subject to compliance with requirements, provide one of the following:
 - a. Hilti, Inc.: CP 506 Smoke and Acoustic Sealant.
 - b. Momentive Performance Materials: RCS20 Siliconized Acrylic Sealant.
 - c. Pecora Corporation: AIS-919.
 - d. Soudal Accumetric: Soudacryl C834.
 - e. Tremco Incorporated: Tremflex 834.
 - f. Approved substitution.
 - 2. Fire Rated Products: Subject to compliance with requirements, provide one of the following:
 - a. BASF Construction Systems: MasterSeal NP 520.
 - b. Henkel Corporation: OSI Pro-Series SC175 Draft & Acoustical Sound Sealant.
 - c. PABCO Gypsum.: QuietSeal Pro.
 - d. Pecora Corporation: AC-20 FTR.
 - e. Specified Technologies Inc. (STI): SpecSeal Smoke 'N' Sound Sealant.
 - f. Approved substitution.
 - 3. Colors of Exposed Acoustical Joint Sealants: As selected by Architect from manufacturer's full range of colors.
 - 4. Movement Capability: Plus/minus 12-1/2 percent.
 - 5. VOC Content: Not more than 55 g/L.
 - 6. Surface-Burning Characteristics: Comply with ASTM E84.
 - a. Flame-Spread Index: 10 or less.
 - b. Smoke-Developed Index: 10 or less.

2.3 MISCELLANEOUS MATERIALS

- A. Primer: Material recommended by acoustical-joint-sealant manufacturer where required for adhesion of sealant to joint substrates.
- B. Cleaners for Nonporous Surfaces: Chemical cleaners acceptable to manufacturers of sealants and sealant backing materials, free of oily residues or other substances capable of staining or harming joint substrates and adjacent nonporous surfaces in any way, and formulated to promote optimum adhesion of sealants to joint substrates.
- C. Masking Tape: Nonstaining, nonabsorbent material compatible with joint sealants and surfaces adjacent to joints.

PART 3 - EXECUTION

3.1 EXAMINATION

- A. Examine joints indicated to receive acoustical joint sealants, with Installer present, for compliance with requirements for joint configuration, installation tolerances, and other conditions affecting performance of the Work.
- B. Proceed with installation only after unsatisfactory conditions have been corrected.

3.2 PREPARATION

- A. Surface Cleaning of Joints: Clean out joints immediately before installing acoustical joint sealants to comply with joint-sealant manufacturer's written instructions.
- B. Joint Priming: Prime joint substrates where recommended by acoustical-joint-sealant manufacturer. Apply primer to comply with joint-sealant manufacturer's written instructions. Confine primers to areas of joint-sealant bond; do not allow spillage or migration onto adjoining surfaces.
- C. Masking Tape: Use masking tape where required to prevent contact of sealant or primer with adjoining surfaces that otherwise would be permanently stained or damaged by such contact or by cleaning methods required to remove sealant smears. Remove tape immediately after tooling without disturbing joint seal.

3.3 INSTALLATION OF ACOUSTICAL JOINT SEALANTS

- A. Comply with acoustical joint-sealant manufacturer's written installation instructions unless more stringent requirements apply.
- B. STC-Rated Assemblies: Seal construction at perimeters, behind control joints, and at openings and penetrations with a continuous bead of acoustical joint sealant. Install acoustical joint sealants at both faces of partitions, at perimeters, and through penetrations. Comply with ASTM C919, ASTM C1193, and manufacturer's written recommendations for closing off sound-flanking paths around or through assemblies, including sealing partitions to underside of floor slabs above acoustical ceilings.
 - 1. Apply acoustical sealant to close gaps between service outlets and penetrations, and gypsum board.
 - 2. Apply acoustical sealant to back of electrical J-boxes for power, telephone, and data prior to installation of gypsum board.
 - 3. Tightly fill gaps around penetrations (ducts, pipes, and conduit 1 inch or less with attenuation batt insulation.
 - 4. Fill gaps larger than 1 inch with putty pads or stick.
 - 5. Apply acoustical sealant at duct and piping penetrations.
- C. Acoustical Ceiling Areas: Apply acoustical joint sealant at perimeter edge moldings of acoustical ceiling areas in a continuous ribbon concealed on back of vertical legs of moldings before they are installed.

3.4 CLEANING

- A. Clean off excess sealant or sealant smears adjacent to joints as Work progresses by methods and with cleaning materials approved in writing by manufacturers of acoustical joint sealants and of products in which joints occur.

3.5 PROTECTION

- A. Protect acoustical joint sealants during and after curing period from contact with contaminating substances and from damage resulting from construction operations or other causes so sealants are without deterioration or damage at time of Substantial Completion. If, despite such protection, damage or deterioration occurs, cut out, remove, and repair damaged or deteriorated acoustical joint sealants immediately so installations with repaired areas are indistinguishable from original Work.

END OF SECTION 079219

SECTION 081113
HOLLOW METAL DOORS AND FRAMES

PART 1 - GENERAL

1.1 SUMMARY

- A. Section Includes:
1. Interior standard steel doors and frames.
 2. Exterior standard steel doors and frames.
 3. Borrowed lites.

1.2 DEFINITIONS

- A. Minimum Thickness: Minimum thickness of base metal without coatings according to SDI A250.8.

1.3 ADMINISTRATIVE REQUIREMENTS

- A. Coordination:
1. Coordinate installation of anchorages for hollow metal frames. Furnish setting drawings, templates, and directions for installing anchorages, including sleeves, concrete inserts, anchor bolts, and items with integral anchors. Deliver such items to Project site in time for installation.
 2. Coordinate requirements for installation of door hardware, electrified door hardware, and access control and security systems.
- B. Preinstallation Meeting: Conduct meeting at Project site.

1.4 ACTION SUBMITTALS

- A. Product Data: For each type of product.
1. Include construction details, material descriptions, core descriptions, fire-resistance ratings, and finishes.
- B. Sustainable Design Submittals:
1. Environmental Product Declaration (EPD): For each product.
 2. Health Product Declaration (HPD): For each product.
 3. Sourcing of Raw Materials: Corporate sustainability report for each manufacturer.
- C. Shop Drawings: Include the following:
1. Elevations of each door and frame type.
 2. Details of doors, including vertical- and horizontal-edge details and metal thicknesses.
 3. Frame details for each frame type, including dimensioned profiles and metal thicknesses.
 4. Locations of reinforcement and preparations for hardware.
 5. Details of each different wall opening condition.
 6. Details of electrical raceway and preparation for electrified hardware, access control systems, and security systems.
 7. Details of anchorages, joints, field splices, and connections.
 8. Details of accessories.
 9. Details of moldings, removable stops, and glazing.
- D. Product Schedule: For hollow-metal doors and frames, prepared by or under supervision of supplier, using same reference numbers for details and openings as those on Drawings. Coordinate with final Door Hardware Schedule.

1.5 INFORMATIONAL SUBMITTALS

- A. Qualification Data: For door inspector.
 - 1. Fire-Rated Door Inspector: Submit documentation of compliance with NFPA 80, Section 5.2.3.1.
 - 2. Egress Door Inspector: Submit documentation of compliance with NFPA 101, Section 7.2.1.15.4.
 - 3. Submit copy of DHI Fire and Egress Door Assembly Inspector (FDAI) certificate.
- B. Product Test Reports: For each type of fire-rated hollow-metal door and frame assembly, fire-rated borrowed-lite assembly, and thermally rated door assemblies for tests performed by a qualified testing agency indicating compliance with performance requirements.

1.6 CLOSEOUT SUBMITTALS

- A. Record Documents: For fire-rated doors, list of door numbers and applicable room name and number to which door accesses.

1.7 QUALITY ASSURANCE

- A. Fire-Rated Door Inspector Qualifications: Inspector for field quality control inspections of fire-rated door assemblies shall meet the qualifications set forth in NFPA 80, section 5.2.3.1 and the following:
 - 1. Door and Hardware Institute Fire and Egress Door Assembly Inspector (FDAI) certification.
- B. Egress Door Inspector Qualifications: Inspector for field quality control inspections of egress door assemblies shall meet the qualifications set forth in NFPA 101, Section 7.2.1.15.4 and the following:
 - 1. Door and Hardware Institute Fire and Egress Door Assembly Inspector (FDAI) certification.

1.8 DELIVERY, STORAGE, AND HANDLING

- A. Deliver hollow-metal doors and frames palletized, packaged, or crated to provide protection during transit and Project-site storage. Do not use nonvented plastic.
 - 1. Provide additional protection to prevent damage to factory-finished units.
- B. Deliver welded frames with 2 removable spreader bars across bottom of frames, tack welded to jambs and mullions.
- C. Store hollow-metal doors and frames vertically under cover at Project site with head up. Place on minimum 4 inch high wood blocking. Provide minimum 1/4 inch space between each stacked door to permit air circulation.

PART 2 - PRODUCTS

2.1 MANUFACTURERS

- A. Manufacturers: Subject to compliance with requirements, provide products by one of the following:
 - 1. Baron Metal Industries, Inc. ; an Assa Abloy Group company.
 - 2. Ceco Door Products; an Assa Abloy Group company.
 - 3. Curries Company; an Assa Abloy Group company.
 - 4. De La Fontaine Inc.
 - 5. Pioneer Industries, Inc.
 - 6. Steelcraft; an Allegion Brand.
 - 7. Approved substitution.
- B. Source Limitations: Obtain hollow-metal Work from single source from single manufacturer.

2.2 PERFORMANCE CRITERIA

- A. Fire-Rated Door Assemblies: Assemblies complying with NFPA 80 that are listed and labeled by a qualified testing agency acceptable to authorities having jurisdiction for fire-protection ratings indicated on Drawings, based on testing at positive pressure according to NFPA 252 or UL 10C.
 - 1. Smoke- and Draft-Control Door Assemblies: Listed and labeled for smoke and draft control by a qualified testing agency acceptable to authorities having jurisdiction, based on testing according to UL 1784 and installed in compliance with NFPA 105.
- B. Fire-Rated, Borrowed-Lite Assemblies: Complying with NFPA 80 and listed and labeled by a qualified testing agency acceptable to authorities having jurisdiction, for fire-protection ratings indicated, based on testing according to NFPA 257 or UL 9.
- C. Thermally Rated Door Assemblies: Provide door assemblies with R-Value of not less than 2.53 when tested according to ASTM C1363.
 - 1. Door Thermal Resistance: R-Value of 0.39 or less.

2.3 INTERIOR STANDARD STEEL DOORS AND FRAMES

- A. Construct hollow-metal doors and frames to comply with standards indicated for materials, fabrication, hardware locations, hardware reinforcement, tolerances, and clearances, and as specified.
- B. Extra-Heavy-Duty Doors and Frames: SDI A250.8, Level 3; SDI A250.4, Level A. At locations indicated in Door Schedule.
 - 1. Doors:
 - a. Type: As indicated in the Door and Frame Schedule.
 - b. Thickness: 1-3/4 inches.
 - c. Face: Uncoated steel sheet, minimum 0.053 inch thick.
 - d. Edge Construction: Model 2, Seamless.
 - e. Edge Bevel: Provide manufacturer's standard beveled edges.
 - f. Core: Vertical steel-stiffeners.
 - g. Fire-Rated Core: Manufacturer's standard core for fire-rated doors.
 - 2. Frames:
 - a. Material: Uncoated steel sheet, minimum 0.067 inch thick.
 - b. Sidelite Frames: Fabricated from same thickness material as adjacent door frame.
 - c. Construction: Face welded.
 - 3. Exposed Finish: Prime.
- C. Frames for Interior Wood Doors: SDI A250.8, Level 3; SDI A250.4, Level A. At locations indicated in Door Schedule.
 - 1. Materials: Uncoated steel sheet, minimum 0.053 inch thick.
 - 2. Construction: Face welded.

2.4 EXTERIOR STANDARD STEEL DOORS AND FRAMES

- A. Construct hollow-metal doors and frames to comply with standards indicated for materials, fabrication, hardware locations, hardware reinforcement, tolerances, and clearances, and as specified.
- B. Extra-Heavy-Duty Doors and Frames: SDI A250.8, Level 3; SDI A250.4, Level A. At locations indicated in Door Schedule.
 - 1. Doors:
 - a. Type: As indicated in the Door and Frame Schedule.
 - b. Thickness: 1-3/4 inches.
 - c. Face: Metallic-coated steel sheet, minimum 0.053 inch thick, with minimum A60 coating.

- d. Edge Construction: Model 2, Seamless.
- e. Edge Bevel: Provide manufacturer's standard beveled edges.
- f. Top Edge Closures: Close top edges of doors with flush closures of same material as face sheets. Seal joints against water penetration.
- g. Bottom Edges: Close bottom edges of doors with end closures or channels of same material as face sheets.
- h. Core: Vertical steel-stiffeners and polyurethane insulation.
- i. Fire-Rated Core: Manufacturer's standard core for fire-rated doors.
- 2. Frames: Flush-mount-type with punch and dimple anchors bolt holes at anchor points.
 - a. Material: Metallic-coated steel sheet, minimum 0.067 inch thick, with minimum A60 coating.
 - b. Construction: Face welded.
- 3. Exposed Finish: Prime.

2.5 BORROWED LITES

- A. Fabricate of uncoated steel sheet, minimum thickness of 0.067 inch
- B. Construction: Face welded.
- C. Fabricate in 1 piece except where handling and shipping limitations require multiple sections. Where frames are fabricated in sections due to shipping or handling limitations, provide alignment plates or angles at each joint, fabricated of metal of same or greater thickness as metal as frames.
- D. Provide countersunk, flat- or oval-head exposed screws and bolts for exposed fasteners unless otherwise indicated.

2.6 FRAME ANCHORS

- A. Jamb Anchors:
 - 1. Type: Anchors of minimum size and type required by applicable door and frame standard, and suitable for performance level indicated.
 - a. Masonry Type: Adjustable strap-and-stirrup or T-shaped anchors to suit frame size, formed from 0.042 inch thick metallic coated steel with minimum A60 coating. Corrugated or perforated straps not less than 2 inches wide by 10 inches long; or wire anchors not less than 0.177 inch thick.
 - b. Stud Wall Type: Not less than 0.042 inch thick steel sheet, designed to engage stud.
 - c. Compression Type for Drywall Slip-on (Knock-Down) Frames: Adjustable compression anchors.
 - 2. Quantity: Minimum of 3 anchors per jamb, with 1 additional anchor for frames with no floor anchor. Provide 1 additional anchor for each 24 inches of frame height above 7 feet.
 - 3. Postinstalled Expansion Anchor: Minimum 3/8-inch-diameter bolts with expansion shields or inserts, with manufacturer's standard pipe spacer.
- B. Floor Anchors: Provide floor anchors for each jamb and mullion that extends to floor.
- C. Floor Anchors for Concrete Slabs with Underlayment: Adjustable-type anchors with extension clips, allowing not less than 2-inch height adjustment. Terminate bottom of frames at top of underlayment.
- D. Material: ASTM A879, Commercial Steel (CS), 04Z coating designation; mill phosphatized.
 - 1. For anchors built into exterior walls, steel sheet complying with ASTM A1008 or ASTM A1011; hot-dip galvanized according to ASTM A153, Class B.

2.7 MATERIALS

- A. Recycled Content of Steel Products: Postconsumer recycled content plus 1/2 of preconsumer recycled content not less than 25 percent.
- B. Cold-Rolled Steel Sheet: ASTM A1008, Commercial Steel (CS), Type B; suitable for exposed applications.
- C. Hot-Rolled Steel Sheet: ASTM A1011, Commercial Steel (CS), Type B; free of scale, pitting, or surface defects; pickled and oiled.
- D. Metallic-Coated Steel Sheet: ASTM A653, Commercial Steel (CS), Type B.
- E. Inserts, Bolts, and Fasteners: Hot-dip galvanized according to ASTM A153.
- F. Power-Actuated Fasteners in Concrete: Fastener system of type suitable for application indicated, fabricated from corrosion-resistant materials, with clips or other accessory devices for attaching hollow-metal frames of type indicated.
- G. Foamed-in-Place Insulation: Manufacturer's standard, closed cell, spray-applied polyurethane type.
- H. Mineral-Fiber Insulation: ASTM C665, Type I (blankets without membrane facing); consisting of fibers manufactured from slag or rock wool.
 - 1. Surface Burning Characteristics: Passes when tested according to ASTM E136 for combustion characteristics
 - a. Flame Spread: 25.
 - b. Smoke Developed: 50.
- I. Glazing: Comply with requirements in Section 088000 – Glazing.
- J. Metal Patching Compound: Metal-filled, 2-component epoxy putty designed for use on various metal substrates.

2.8 FABRICATION

- A. Fabricate hollow-metal Work to be rigid and free of defects, warp, or buckle. Accurately form metal to required sizes and profiles, with minimum radius for metal thickness. Where practical, fit and assemble units in manufacturer's plant. To ensure proper assembly at Project site, clearly identify Work that cannot be permanently factory assembled before shipment.
- B. Provide doors and frames receiving electrified hardware with 1/2 inch flexible steel conduit, including sufficient number of conductor wires, to accommodate electric function specified; connectors, and cover box installed at each location electrified hardware is specified.
 - 1. Properly coordinate installation of mechanical hardware and hook-up of electrified function with company that is licensed by Washington Electricity Board to prevent voiding of manufacturer's warranty and labeling of opening.
- C. Hollow Metal Doors:
 - 1. Reinforcement: 1-piece steel channels continuously welded full length to face sheets.
 - a. Lock Channel: 0.067 inch thick steel, beveled 1/8 inch in 2 inch.
 - b. Hinge Channel: 0.093 inch thick steel [**extruded to 7 gauge equivalent**], formed and tapered for hinges.
 - c. Top and Bottom Channels: 0.053 inch thick steel with flush channel filler cap to close top rail opening.
 - 1) Snap in caps are not accepted.
 - 2) Provide weep-hole openings in bottoms of exterior doors to permit moisture to escape.
 - d. Closer Reinforcement Channel: 0.067 inch thick steel.

2. Cores:
 - a. Interior Doors: 0.042 inch thick vertical steel-stiffener welded in-place at 6 inches on center.
 - 1) Kraft paper honeycomb cores are not acceptable.
 - b. Exterior and Insulated Doors: 0.042 inch thick vertical steel-stiffener welded in-place at 6 inches on center; filled with manufacturer's standard foamed-in-place polyurethane; faces chemically bonded to face sheets.
 - 1) Kraft paper honeycomb cores are not acceptable.
 - D. Hollow-Metal Frames: Fabricate in 1 piece except where handling and shipping limitations require multiple sections. Where frames are fabricated in sections, provide alignment plates or angles at each joint, fabricated of metal of same or greater thickness as frames.
 1. Sidelite Frames: Provide closed tubular members with no visible face seams or joints, fabricated from same material as door frame. Fasten members at crossings and to jambs by welding.
 2. Provide countersunk, flat- or oval-head exposed screws and bolts for exposed fasteners unless otherwise indicated.
 3. Thermal Breaks Fabricate frames with minimum 1/16 inch positive thermal break and integral vinyl weatherstripping as required to meet specified door assembly U-values.
 4. Faces: 2 inch.
 5. Rabbets: Double 5/8 inch unless indicated otherwise.
 6. Backbends:
 - a. Wrap-Around Frames: Manufacturer's standard 1/2 inch nominal backbend.
 - b. Butted Frames: Custom 1-1/2 inch minimum backbends.
 7. Door Silencers: Except on weather-stripped frames, drill stops to receive door silencers as follows. Keep holes clear during construction.
 - a. Single-Door Frames: Drill stop in strike jamb to receive 3 door silencers.
 - b. Double-Door Frames: Drill stop in head jamb to receive 2 door silencers.
 - E. Hardware Preparation: Factory prepare hollow-metal doors and frames to receive templated mortised hardware, and electrical wiring; include cutouts, reinforcement, mortising, drilling, and tapping according to SDI A250.6, the Door Hardware Schedule, and templates.
 1. Reinforce doors and frames to receive nontemplated, mortised, and surface-mounted door hardware.
 2. Comply with BHMA A156.115 for preparing hollow-metal doors and frames for hardware.
 - F. Glazed Lites: Provide stops and moldings around glazed lites where indicated. Form corners of stops and moldings with butted or mitered hairline joints.
 1. Provide stops and moldings flush with face of door, and with square stops unless otherwise indicated.
 2. Multiple Glazed Lites: Provide fixed and removable stops and moldings so that each glazed lite is capable of being removed independently.
 3. Provide fixed frame moldings on outside of exterior frames and on unsecured side of interior frames. Provide loose stops and moldings on inside of hollow-metal frames.
 4. Coordinate rabbet width between fixed and removable stops with glazing and installation types indicated.
 5. Provide stops for installation with countersunk flat- or oval-head machine screws spaced uniformly not more than 9 inches on center and not more than 2 inches on center from each corner.
- 2.9 STEEL FINISHES
- A. Prime Finish: Clean, pretreat, and apply manufacturer's standard primer.
 1. Shop Primer: Manufacturer's standard, fast-curing, lead- and chromate-free primer complying with SDI A250.10; recommended by primer manufacturer for substrate; compatible with substrate and field-applied coatings despite prolonged exposure.

2.10 LOUVERS

- A. Provide louvers for interior doors, where indicated, which comply with SDI 111, with blades or baffles formed of 0.020 inch thick, cold-rolled steel sheet set into 0.032 inch-thick steel frame.
 - 1. Sightproof Louver: Stationary louvers constructed with inverted-V or inverted-Y blades.
- B. Form corners of moldings with hairline joints. Provide fixed frame moldings on outside of exterior and on secure side of interior doors and frames.

PART 3 - EXECUTION

3.1 PREPARATION

- A. Remove welded-in shipping spreaders installed at factory. Restore exposed finish by grinding, filling, and dressing, as required to make repaired area smooth, flush, and invisible on exposed faces. Touch up factory-applied finishes where spreaders are removed.
- B. Drill and tap doors and frames to receive nontemplated, mortised, and surface-mounted door hardware.

3.2 INSTALLATION

- A. Install hollow-metal doors and frames plumb, rigid, properly aligned, and securely fastened in place. Comply with approved Shop Drawings and with manufacturer's written instructions.
- B. Hollow-Metal Frames: Comply with ANSI/SDI A250.11.
 - 1. Set frames accurately in position; plumbed, aligned, and braced securely until permanent anchors are set. After wall construction is complete, remove temporary braces without damage to completed Work.
 - a. Where frames are fabricated in sections, field splice at approved locations by welding face joint continuously; grind, fill, dress, and make splice smooth, flush, and invisible on exposed faces. Touch-up finishes.
 - b. Install frames with removable stops located on secure side of opening.
 - 2. Exterior Frames: After installation of anchor bolts is completed, fill dimpled anchor openings with metal patching compound. Cure and prep patching compound as recommended by patching compound manufacturer; ready for painting.
 - 3. Fire-Rated Openings: Install frames according to NFPA 80.
 - 4. Floor Anchors: Secure with postinstalled expansion anchors.
 - a. Floor anchors may be set with power-actuated fasteners instead of postinstalled expansion anchors if so indicated and approved on Shop Drawings.
 - 5. Fill inside of frames with spray-applied and insulation.
 - a. Locations: Exterior locations and where else indicated.
 - 6. Masonry Walls: Coordinate installation of frames to allow for solidly filling space between frames and masonry with spray-applied insulation or packed mineral-fiber insulation.
 - 7. In-Place Concrete or Masonry Construction: Secure frames in place with postinstalled expansion anchors. Countersink anchors, and fill and make smooth, flush, and invisible on exposed faces.
 - 8. Installation Tolerances: Adjust hollow-metal frames to the following tolerances:
 - a. Squareness: Plus or minus 1/16 inch, measured at door rabbet on a line 90 degrees from jamb perpendicular to frame head.
 - b. Alignment: Plus or minus 1/16 inch, measured at jambs on a horizontal line parallel to plane of wall.
 - c. Twist: Plus or minus 1/16 inch, measured at opposite face corners of jambs on parallel lines, and perpendicular to plane of wall.
 - d. Plumbness: Plus or minus 1/16 inch, measured at jambs at floor.

- C. Hollow-Metal Doors: Fit and adjust hollow-metal doors accurately in frames, within clearances specified below.
 - 1. Non-Fire-Rated Steel Doors: Comply with SDI A250.8.
 - 2. Fire-Rated Doors: Install doors with clearances according to NFPA 80.
 - 3. Smoke-Control Doors: Install doors according to NFPA 105.
- D. Glazing: Comply with installation requirements in Section 088000 – Glazing and with hollow-metal manufacturer's written instructions.

3.3 FIELD QUALITY CONTROL

- A. Inspection Agency: Owner will engage a qualified inspector to perform inspections and to furnish reports to Architect.
- B. Inspections:
 - 1. Fire-Rated Door Inspections: Inspect each fire-rated door according to NFPA 80, Section 5.2.
 - 2. Egress Door Inspections: Inspect each door equipped with panic hardware, each door equipped with fire exit hardware, each door located in an exit enclosure, each electrically controlled egress door, and each door equipped with special locking arrangements according to NFPA 101, section 7.2.1.15.
- C. Repair or remove and replace installations where inspections indicate that they do not comply with specified requirements.
- D. Reinspect repaired or replaced installations to determine if replaced or repaired door assembly installations comply with specified requirements.
- E. Prepare and submit separate inspection report for each fire-rated door assembly indicating compliance with each item listed in NFPA 80 and NFPA 101.

3.4 CLEANING AND TOUCHUP

- A. Prime-Coat Touchup: Immediately after erection, sand smooth rusted or damaged areas of prime coat and apply touchup of compatible air-drying, rust-inhibitive primer.
- B. Metallic-Coated Surface Touchup: Clean abraded areas and repair with galvanizing repair paint according to manufacturer's written instructions.
- C. Touchup Painting: Cleaning and touchup painting of abraded areas of paint are specified in painting Sections.

END OF SECTION 081113

SECTION 081416
FLUSH WOOD DOORS

PART 1 - GENERAL

1.1 SUMMARY

- A. Section Includes:
1. 5-ply flush wood veneer-faced doors for transparent finish.
 2. 5-ply flush wood veneer-faced doors for opaque finish.
 3. Factory priming and finishing flush wood doors.
 4. Factory fitting flush wood doors to frames and factory machining for hardware.

1.2 ADMINISTRATIVE REQUIREMENTS

- A. Preinstallation Meetings: Conduct meeting at Project site.

1.3 ACTION SUBMITTALS

- A. Product Data: For each type of product, including the following:
1. Door core materials and construction.
 2. Door edge construction
 3. Door face type and characteristics.
 4. Door louvers.
 5. Door trim for openings.
 6. Door frame construction.
 7. Factory-machining criteria.
 8. Factory-finishing specifications.
- B. Sustainable Design Submittals:
1. Environmental Product Declaration (EPD): For each product.
 2. Health Product Declaration (HPD): For each product.
 3. Chain-of-Custody Certificates: For certified wood products. Include statement of costs.
 4. Chain-of-Custody Qualification Data: For manufacturer and vendor.
 5. Laboratory Test Reports: For adhesives, indicating compliance with requirements for low-emitting materials.
 6. Laboratory Test Reports: For composite wood products, indicating compliance with requirements for low-emitting materials.
- C. Shop Drawings: Indicate location, size, and hand of each door; elevation of each type of door; construction details not covered in Product Data; and the following:
1. Door schedule indicating door location, type, size, fire protection rating, and swing.
 2. Door elevations, dimension and locations of hardware, lite cutouts, louver cutouts, and glazing thicknesses.
 3. Details of electrical raceway and preparation for electrified hardware, access control systems, and security systems.
 4. Dimensions and locations of blocking for hardware attachment.
 5. Dimensions and locations of mortises and holes for hardware.
 6. Clearances and undercuts.
 7. Requirements for veneer matching.
 8. Doors to be factory primed or finished and application requirements.
 9. Apply WDMA Hallmark Certification Program label to Shop Drawings.

- D. Samples for Verification:
 - 1. Factory finishes applied to actual door face materials, approximately 8 by 10 inches, for each material and finish. For each wood species and transparent finish, provide set of 3 Samples showing typical range of color and grain to be expected in finished Work.
 - 2. Corner sections of doors, approximately 8 by 10 inches, with door faces and edges representing actual materials to be used.
 - 3. Louver blade and frame sections, 6 inches long, for each material and finish specified.
 - 4. Frames for light openings, 6 inches long, for each material, type, and finish required.

1.4 INFORMATIONAL SUBMITTALS

- A. Qualification Data: For door inspector.
 - 1. Fire-Rated Door Inspector: Submit documentation of compliance with NFPA 80, Section 5.2.3.1.
 - 2. Egress Door Inspector: Submit documentation of compliance with NFPA 101, Section 7.2.1.15.4.
 - 3. Submit copy of DHI's Fire and Egress Door Assembly Inspector (FDAI) certificate.
- B. Sample Warranty: For special warranty.

1.5 CLOSEOUT SUBMITTALS

- A. Quality Standard Compliance Certificates: WDMA Hallmark Certification Program certificates.
- B. Record Documents: For fire-rated doors, list of door numbers and applicable room name and number to which door accesses.

1.6 QUALITY ASSURANCE

- A. Certified Wood: Provide an invoice including vendor's chain-of-custody number, product cost, and entity being invoiced.
- B. Vendor Qualifications: A vendor that is certified for chain of custody by an FSC-accredited certification body.
- C. Manufacturer's Certification: Licensed participant in WDMA Hallmark Certification Program.
- D. Fire-Rated Door Inspector Qualifications: Inspector for field quality-control inspections of fire-rated door assemblies shall comply with qualifications set forth in NFPA 80, Section 5.2.3.1 and the following:
 - 1. DHI's Fire and Egress Door Assembly Inspector (FDAI) certification.
- E. Egress Door Inspector Qualifications: Inspector for field quality-control inspections of egress door assemblies shall comply with qualifications set forth in NFPA 101, Section 7.2.1.15.4 and the following:
 - 1. DHI's Fire and Egress Door Assembly Inspector (FDAI) certification.

1.7 DELIVERY, STORAGE, AND HANDLING

- A. Comply with requirements of referenced standard and manufacturer's written instructions.
- B. Package doors individually in cardboard cartons, and wrap bundles of doors in plastic sheeting.
 - 1. Do not store in damp or wet areas; or in areas where sunlight might bleach veneer. Seal top and bottom edges with tinted sealer if stored more than 1 week. Break seal on site to permit ventilation/
- C. Mark each door on bottom rail with opening number used on Shop Drawings.

1.8 FIELD CONDITIONS

- A. Environmental Limitations: Do not deliver or install doors until spaces are enclosed and weathertight, wet-work in spaces is complete and dry, and HVAC system is operating and maintaining temperature and relative humidity at levels designed for building occupants for remainder of construction period.

1.9 WARRANTY

- A. Special Warranty: Manufacturer agrees to repair or replace doors that fail in materials or workmanship within specified warranty period.
 - 1. Failures include the following:
 - a. Delamination of veneer.
 - b. Warping (bow, cup, or twist) more than 1/4 inch in a 42 by 84 inch section.
 - c. Telegraphing of core construction in face veneers exceeding 0.01 inch in a 3 inch span.
 - 2. Warranty shall also include installation and finishing that may be required due to repair or replacement of defective doors.
 - 3. Warranty Period for Solid-Core Interior Doors: Life of installation.
 - 4. Warranty Period for Hollow-Core Interior Doors: 1 year from date of Substantial Completion.

PART 2 - PRODUCTS

2.1 MANUFACTURERS

- A. Manufacturers: Subject to compliance with requirements, provide products by one of the following:
 - 1. ASSA ABLOY Wood Doors.
 - 2. Eggers Industries.
 - 3. Lynden Door, Inc.
 - 4. Masonite Architectural.
 - 5. Oregon Door.
 - 6. Vancouver Architectural Doors.
 - 7. VT Industries, Inc.
- B. Source Limitations: Obtain flush wood doors from single manufacturer.

2.2 PERFORMANCE CRITERIA

- A. Fire-Rated Wood Door Assemblies: Assemblies complying with NFPA 80 that are listed and labeled by a qualified testing agency acceptable to authorities having jurisdiction, for fire-protection ratings indicated on Drawings, based on testing at positive pressure in accordance with UL 10C or NFPA 252.
- B. Smoke- and Draft-Control Door Assemblies: Listed and labeled for smoke and draft control by a qualified testing agency acceptable to authorities having jurisdiction, based on testing in accordance with UL 1784 and installed in compliance with NFPA 105.

2.3 FLUSH WOOD DOORS, GENERAL

- A. Quality Standard: In addition to requirements specified, comply with ANSI/WDMA I.S. 1A.
 - 1. Contract Documents contain requirements that are more stringent than referenced quality standard. Comply with Contract Documents in addition to those of referenced quality standard.
- B. Certified Wood: Wood doors shall be certified as "FSC Pure" according to FSC STD-01-001 and FSC STD-40-004.
- C. Adhesives: Use adhesives that meet testing and product requirements of California Department of Public Health's "Standard Method for the Testing and Evaluation of Volatile Organic Chemical Emissions from Indoor Sources Using Environmental Chambers."

- D. Composite Wood Products: Products shall be made using ultra-low-emitting formaldehyde resins as defined in the California Air Resources Board's "Airborne Toxic Control Measure to Reduce Formaldehyde Emissions from Composite Wood Products" or shall be made with no added formaldehyde.

2.4 SOLID-CORE 5-PLY FLUSH WOOD VENEER-FACED DOORS FOR TRANSPARENT FINISH

A. Interior Doors:

1. Performance Grade:
 - a. ANSI/WDMA I.S. 1A Heavy Duty: Public toilets, janitor's closets, and where indicated on Drawings.
 - b. ANSI/WDMA I.S. 1A Extra Heavy Duty: Exits and where indicated on Drawings.
2. ANSI/WDMA I.S. 1A Grade: Custom.
3. Faces: Single-ply wood veneer not less than 1/50 inch thick.
 - a. Species: Western red cedar
 - b. Cut: Plain sliced (flat sliced).
 - c. Match Between Veneer Leaves: Book match.
 - d. Assembly of Veneer Leaves on Door Faces: Running match.
 - e. Pair and Set Match: Provide for doors hung in same opening or separated only by mullions.
4. Exposed Vertical and Top Edges: Applied wood edges of same species as faces and covering edges of crossbands – Architectural Woodwork Standards edge Type D.
 - a. Fire-Rated Single Doors: Provide edge construction with intumescent seals concealed by outer stile. Comply with specified requirements for exposed vertical edges.
 - b. Fire-Rated Pairs of Doors: Provide fire-retardant stiles that are listed and labeled for applications indicated without formed-steel edges and astragals. Provide stiles with concealed intumescent seals. Comply with specified requirements for exposed edges.
 - c. Mineral-Core Doors: At hinge stiles, provide laminated-edge construction with improved screw-holding capability and split resistance. Comply with specified requirements for exposed edges.
 - 1) Screw-Holding Capability: in accordance with WDMA T.M. 10, as required for Performance Grades specified.
5. Core for Non-Fire-Rated Doors:
 - a. WDMA I.S. 10 structural composite lumber.
 - 1) Screw Withdrawal, Door Face: 475 lbf.
 - 2) Screw Withdrawal, Vertical Door Edge: 475 lbf..
6. Core for Fire-Rated Doors: As required to achieve fire-protection rating indicated on Drawings.
 - a. Blocking for Mineral-Core Doors: Provide composite blocking with improved screw-holding capability approved for use in doors of fire-protection ratings indicated on Drawings as needed to eliminate through-bolting hardware.
7. Construction: 5 plies, hot-pressed bonded (vertical and horizontal edging is bonded to core), with entire unit abrasive planed before veneering.

2.5 HOLLOW-CORE FLUSH WOOD DOORS FOR OPAQUE FINISH

A. Interior Doors:

1. Performance Grade: WDMA ANSI/I.S. 1A Standard Duty.
2. ANSI/WDMA I.S. 1A Grade: Custom.
3. Faces: Any closed-grain hardwood of mill option.
4. Exposed Vertical and Top Edges: Any closed-grain hardwood.
5. Construction: Standard hollow core.
6. Blocking: Provide wood blocking as needed to eliminate through-bolting hardware.

2.6 LIGHT FRAMES AND LOUVERS

- A. Metal Frames for Light Openings in Fire-Rated Doors: Manufacturer's standard frame formed of 0.048 inch thick, cold-rolled steel sheet; with baked-enamel- or powder-coated finish; and approved for use in doors of fire-protection rating indicated on Drawings.
- B. Metal Louvers:
 - 1. Blade Type: Vision-proof, inverted V or Y.
 - 2. Metal and Finish: Hot-dip galvanized steel, 0.040 inch thick, with baked-enamel- or powder-coated finish.
- C. Louvers for Fire-Rated Doors: Metal louvers with fusible link and closing device, listed and labeled for use in doors with fire-protection rating of 1-1/2 hours and less.
 - 1. Metal and Finish: Hot-dip galvanized steel, 0.040 inch thick, with baked-enamel- or powder-coated finish.

2.7 FABRICATION

- A. Factory fit doors to suit frame-opening sizes indicated.
 - 1. Comply with clearance requirements of referenced quality standard for fitting unless otherwise indicated.
 - 2. Comply with NFPA 80 requirements for fire-rated doors.
- B. Factory machine doors for hardware that is not surface applied.
 - 1. Locate hardware to comply with DHI-WDHS-3.
 - 2. Comply with final hardware schedules, door frame Shop Drawings, ANSI/BHMA-156.115-W, and hardware templates.
 - 3. Coordinate with hardware mortises in metal frames, to verify dimensions and alignment before factory machining.
 - 4. For doors scheduled to receive electrified locksets, provide factory-installed raceway and wiring to accommodate specified hardware.
 - 5. Metal Astragals: Factory machine astragals and formed-steel edges for hardware for pairs of fire-rated doors.
- C. Openings: Factory cut and trim openings through doors.
 - 1. Light Openings: Trim openings with moldings of material and profile indicated.
 - 2. Glazing: Factory install glazing in doors indicated to be factory finished. Comply with applicable requirements in Section 088000 – Glazing.
 - 3. Louvers: Factory install louvers in prepared openings.
 - 4. Seal edges of doors, edges of cutouts, and mortises after fitting and machining.

2.8 FACTORY PRIMING

- A. Doors for Opaque Finish: Factory prime faces, all 4 edges, edges of cutouts, and mortises with 1 coat of wood primer specified in Section 099000 – Painting and Coating.

2.9 FACTORY FINISHING

- A. Comply with referenced quality standard for factory finishing.
 - 1. Complete fabrication, including fitting doors for openings and machining for hardware that is not surface applied, before finishing.
 - 2. Finish faces, all 4 edges, edges of cutouts, and mortises.
 - 3. Stains and fillers may be omitted on bottom edges, edges of cutouts, and mortises.
- B. Factory finish doors unless indicated otherwise.

- C. Transparent Finish:
 - 1. ANSI/WDMA I.S. 1A Grade: Custom.
 - 2. Finish: ANSI/WDMA I.S. 1A TR-6 Catalyzed Polyurethane.
 - 3. Staining: As selected by Architect from manufacturer's full range.
 - 4. Sheen: Satin.

- D. Opaque Finish:
 - 1. ANSI/WDMA I.S. 1A Grade: Custom.
 - 2. Finish: ANSI/WDMA I.S. 1A OP-6 Catalyzed Polyurethane.
 - 3. Color: As selected by Architect from manufacturer's full range.
 - 4. Sheen: Satin.

PART 3 - EXECUTION

3.1 EXAMINATION

- A. Examine doors and installed door frames, with Installer present, before hanging doors.
 - 1. Verify that installed frames comply with indicated requirements for type, size, location, and swing characteristics and have been installed with level heads and plumb jambs.
 - 2. Reject doors with defects.

- B. Proceed with installation only after unsatisfactory conditions have been corrected.

3.2 INSTALLATION

- A. Hardware: For installation, see Section 087100 – Door Hardware.

- B. Install doors to comply with manufacturer's written instructions and referenced quality standard, and as indicated.

- C. Install frames level, plumb, true, and straight.
 - 1. Shim as required with concealed shims. Install level and plumb to a tolerance of 1/8 inch in 96 inches.
 - 2. Anchor frames to anchors or blocking built in or directly attached to substrates.
 - a. Secure with countersunk, concealed fasteners and blind nailing.
 - b. Use fine finishing nails or finishing screws for exposed fastening, countersunk and filled flush with woodwork.
 - 1) For factory-finished items, use filler matching finish of items being installed.
 - 3. Install fire-rated doors and frames in accordance with NFPA 80.
 - 4. Install smoke- and draft-control doors in accordance with NFPA 105.

- D. Job-Fitted Doors: Align and fit doors in frames with uniform clearances and bevels as indicated.
 - 1. Do not trim stiles and rails in excess of limits set by manufacturer or permitted for fire-rated doors.
 - 2. Machine doors for hardware.
 - 3. Seal edges of doors, edges of cutouts, and mortises after fitting and machining.
 - 4. Clearances:
 - a. Provide 1/8 inch at heads, jambs, and between pairs of doors.
 - b. Provide 1/8 inch from bottom of door to top of decorative floor finish or covering unless otherwise indicated on Drawings.
 - c. Where threshold is shown or scheduled, provide 1/4 inch from bottom of door to top of threshold unless otherwise indicated.
 - d. Comply with NFPA 80 for fire-rated doors.
 - 5. Bevel non-fire-rated doors 1/8 inch in 2 inches at lock and hinge edges.
 - 6. Bevel fire-rated doors 1/8 inch in 2 inches at lock edge; trim stiles and rails only to extent permitted by labeling agency.

- E. Factory-Fitted Doors: Align in frames for uniform clearance at each edge.
- F. Factory-Finished Doors: Restore finish before installation if fitting or machining is required at Project site.

3.3 FIELD QUALITY CONTROL

- A. Inspection Agency: Owner will engage a qualified inspector to perform inspections and to furnish reports to Architect.
- B. Inspections:
 - 1. Provide inspection of installed Work through WDMA Hallmark Certification Program, certifying that wood doors and frames, including installation, comply with requirements of WDMA standards for specified grades.
 - 2. Fire-Rated Door Inspections: Inspect each fire-rated door in accordance with NFPA 80, Section 5.2.
 - 3. Egress Door Inspections: Inspect each door equipped with panic hardware, each door equipped with fire exit hardware, each door located in an exit enclosure, each electrically controlled egress door, and each door equipped with special locking arrangements in accordance with NFPA 101, Section 7.2.1.15.
- C. Repair or remove and replace installations where inspections indicate that they do not comply with specified requirements.
- D. Reinspect repaired or replaced installations to determine if replaced or repaired door assembly installations comply with specified requirements.
- E. Prepare and submit separate inspection report for each fire-rated door assembly indicating compliance with each item listed in NFPA 80 and NFPA 101.

3.4 ADJUSTING

- A. Operation: Rehang or replace doors that do not swing or operate freely.
- B. Finished Doors: Replace doors that are damaged or that do not comply with requirements. Doors may be repaired or refinished if Work complies with requirements and shows no evidence of repair or refinishing.

END OF SECTION 081416

SECTION 083113
ACCESS DOORS AND FRAMES

PART 1 - GENERAL

1.1 SUMMARY

- A. Section Includes:
 - 1. Access doors and frames for walls and ceilings.

1.2 ADMINISTRATIVE REQUIREMENTS

- A. Coordination:
 - 1. Verification: Determine specific locations and sizes for access doors needed to gain access to concealed plumbing, mechanical, or other concealed Work, and indicate in schedule specified in "Submittals" Article.
- B. Ceiling Coordination Drawings:
 - 1. Reflected ceiling plans, drawn to scale, on which ceiling-mounted items including access doors and frames, lighting fixtures, diffusers, grilles, speakers, sprinklers, and special trim are shown and coordinated with each other.

1.3 ACTION SUBMITTALS

- A. Product Data: For each type of product.
 - 1. Include construction details, fire ratings if applicable, material, individual components and profiles, and finishes.
- B. Product Schedule: For access doors and frames. Use same designations indicated on Drawings if indicated.

1.4 INFORMATIONAL SUBMITTALS

- A. Qualification Data: For testing and inspecting agency.
 - 1. Fire-Rated Door Inspector: Submit documentation of compliance with NFPA 80, section 5.2.3.1.

1.5 CLOSEOUT SUBMITTALS

- A. Record Documents: For fire-rated doors, list of applicable room name and number in which

PART 2 - PRODUCTS

2.1 MANUFACTURERS

- A. Source Limitations: Obtain each type of access door and frame from single source from single manufacturer.

2.2 PERFORMANCE CRITERIA

- A. Fire-Rated Access Doors and Frames: Assemblies complying with NFPA 80 that are listed and labeled by a qualified testing agency, for fire- protection ratings indicated, according to NFPA 252 or UL 10B.
- B. Design Requirements:

1. Door Sizes, General: Provide access doors and frames in the following sizes, unless indicated otherwise:
 - a. Walls: 12 inch square. 24 inch square for "reach in" access.
 - b. Ceilings: 24 by 24 inch or 22 by 30 inch.
2. Smoke Gaskets: Face of door flush with frame, gasketed, with concealed flange for gypsum board installation. Provide gaskets for access door and frame assemblies in the following locations:
 - a. Isolation rooms.
 - b. Rooms with negative pressure.
 - c. Exterior locations.

2.3 NON-RATED ACCESS DOORS AND FRAMES

A. Flush Access Doors with Exposed Flange:

1. Products: Subject to compliance with requirements, provide products by one of the following:
 - a. Babcock-Davis: BNT.
 - b. JL Industries, Inc.; Div. of Activar Construction Products Group: TM.
 - c. Karp Associates, Inc.: Model DCS-214M.
 - d. Larsen's Manufacturing Company: L-DW.
 - e. Milcor Company: M Series.
 - f. Nystrom, Inc.: NT.
 - g. Williams Brothers Corporation of America: WB-UAD-200.
 - h. Approved substitution.
2. Description: Face of door flush with frame, with minimum 1 inch exposed flange and concealed hinge.
3. Door Material:
 - a. Uncoated Steel Sheet for Door: Nominal 0.060 inch, factory primed.
 - b. Metallic-Coated Steel Sheet for Door: Nominal 0.064 inch, factory primed.
4. Frame Material: Same material, thickness, and finish as door.
5. Latch and Lock: Cam latch, screwdriver operated [**Cam latch, key operated**] [**Prepared for mortise cylinder**].
6. Locations:
 - a. Walls: Interior gypsum board [**tile**] [**and**] [**masonry**].
 - b. Ceilings: Interior gypsum board.

B. Flush Access Doors with Concealed Flanges:

1. Products: Subject to compliance with requirements, provide products by one of the following:
 - a. Babcock-Davis: BNW.
 - b. JL Industries, Inc.; Div. of Activar Construction Products Group: TMW.
 - c. Karp Associates, Inc.: Model KDW.
 - d. Larsen's Manufacturing Company: L-DWB.
 - e. Milcor Company: DW Standard Flush Door.
 - f. Nystrom, Inc.: NW.
 - g. Williams Brothers Corporation of America: WB-WD 400 Series.
 - h. Approved substitution.
2. Description: Face of door flush with frame; with concealed flange for gypsum board installation and concealed hinge.
3. Door Material:
 - a. Uncoated Steel Sheet for Door: Nominal 0.060 inch, factory primed.
 - b. Metallic-Coated Steel Sheet for Door: Nominal 0.064 inch, factory primed.
4. Frame Material: Same material, thickness, and finish as door.
5. Latch and Lock: Cam latch, screwdriver operated [**Cam latch, key operated**] [**Prepared for mortise cylinder**].
6. Locations:
 - a. Walls: Interior gypsum board [**tile**] [**and**] [**masonry**].

- b. Ceilings: Interior gypsum board.

2.4 FIRE-RATED ACCESS DOORS AND FRAMES

A. Fire-Rated, Flush Access Doors with Exposed Flanges:

1. Products: Subject to compliance with requirements, provide products by one of the following:
 - a. Acudor Products, Inc.: FW-5050.
 - b. Babcock-Davis: BIT.
 - c. JL Industries, Inc.; Div. of Activar Construction Products Group: FD Series.
 - d. Karp Associates, Inc.: KPR-150FR.
 - e. Larsen's Manufacturing Company: L-FRC.
 - f. Milcor Company: UFR.
 - g. Nystrom, Inc.: IT.
 - h. Williams Brothers Corporation of America: WB-FR 800 Series.
 - i. Approved substitution.
2. Description: Door face flush with frame, with a core of mineral-fiber insulation enclosed in sheet metal; with exposed flange, self-closing door, and concealed hinge.
3. Door Material:
 - a. Door Thickness: Nominal 0.040 inch uncoated steel sheet, factory primed.
4. Frame Material:
 - a. Frame Thickness: Nominal 0.060 inch uncoated steel sheet, factory primed.
5. Fire-Resistance Rating: Not less than that of adjacent construction that indicated unless indicated otherwise.
6. Latch and Lock: Self-latching door hardware, prepared for mortise cylinder [**operated by key**].
7. Locations: Interior gypsum board walls and ceilings.

B. Fire-Rated, Flush Access Doors and Concealed:

1. Products: Subject to compliance with requirements, provide products by one of the following:
 - a. Acudor Products, Inc.: FW-5050-DW.
 - b. Babcock-Davis: BIW.
 - c. JL Industries, Inc.; Div. of Activar Construction Products Group: FDW Series.
 - d. Karp Associates, Inc.: KPR-350FR.
 - e. Milcor Company: UFR-DW.
 - f. Nystrom, Inc.: IW.
 - g. Williams Brothers Corporation of America: WB-FR-DW 820 Series.
 - h. Approved substitution.
2. Description: Door face flush with frame, with a core of mineral-fiber insulation enclosed in sheet metal; with concealed flange for gypsum board installation, self-closing door, and concealed hinge.
3. Door Material:
 - a. Door Thickness: Nominal 0.040 inch uncoated steel sheet, factory primed.
4. Frame Material:
 - a. Frame Thickness: Nominal 0.060 inch uncoated steel sheet, factory primed.
5. Fire-Resistance Rating: Not less than that of adjacent construction that indicated unless indicated otherwise.
6. Latch and Lock: Self-latching door hardware, prepared for mortise cylinder [**operated by key**].
7. Locations: Interior gypsum board walls and ceilings.

2.5 MATERIALS

- A. Steel Plates, Shapes, and Bars: ASTM A36.
- B. Steel Sheet: Uncoated or electrolytic zinc coated, ASTM A879, with cold-rolled steel sheet substrate complying with ASTM A1008, Commercial Steel (CS), exposed.

- C. Metallic-Coated Steel Sheet: ASTM A653, Commercial Steel (CS) Type B; with minimum G60 or A60 metallic coating.
 - 1. Provide access doors and frames with metallic-coated steel sheet at exterior soffit locations in lieu of uncoated steel sheet
- D. Stainless-Steel Sheet, Strip, Plate, and Flat Bars: ASTM A666, Type 304. Remove tool and die marks and stretch lines or blend into finish.
 - 1. Finish: Directional Satin Finish, No. 4.
- E. Gaskets: Manufacturer's standard urethane, neoprene, or santoprene gasket designed to form smoke **[and] [weathertight]** seal between door and frame.
- F. Frame Anchors: Same type as door face.
- G. Inserts, Bolts, and Anchor Fasteners: Hot-dip galvanized steel per ASTM A153 or ASTM F2329.

2.6 FABRICATION

- A. General: Provide access door and frame assemblies manufactured as integral units ready for installation.
- B. Metal Surfaces: For metal surfaces exposed to view in completed Work, provide materials with smooth, flat surfaces without blemishes. Do not use materials with exposed pitting, seam marks, roller marks, rolled trade names, or roughness.
- C. Doors and Frames: Grind exposed welds smooth and flush with adjacent surfaces. Furnish attachment devices and fasteners of type required to secure access doors to types of supports indicated.
 - 1. For concealed flanges with drywall bead, provide edge trim for gypsum board securely attached to perimeter of frames.
- D. Recessed Access Doors: Form face of door panel to provide recess for application of applied finish. Reinforce door panel as required to prevent buckling. Provide access sleeves for each latch operator and install in holes cut through finish.
- E. Latch and Lock Hardware:
 - 1. Quantity: Furnish number of latches and locks required to hold doors tightly closed.
 - 2. Keys: Furnish 2 keys per lock and key all locks alike.
 - 3. Mortise Cylinder Preparation: Where indicated, prepare door panel to accept cylinder specified in Section 087100 – Door Hardware.

2.7 FINISHES

- A. Comply with NAAMM's "Metal Finishes Manual for Architectural and Metal Products" for recommendations for applying and designating finishes.
- B. Protect mechanical finishes on exposed surfaces from damage by applying a strippable, temporary protective covering before shipping.
- C. Appearance of Finished Work: Noticeable variations in same piece are not acceptable. Variations in appearance of adjoining components are acceptable if they are within range of approved Samples and are assembled or installed to minimize contrast.
- D. Painted Finishes: Comply with coating manufacturer's written instructions for cleaning, conversion coating, and applying and baking finish.
 - 1. ~~Factory Primed: Apply manufacturer's standard, lead- and chromate-free, universal primer immediately after surface preparation and pretreatment.~~

2. Factory Finished: Apply manufacturer's standard baked-enamel or powder-coat finish immediately after cleaning and pretreating, with a minimum dry-film thickness of 1 mil for topcoat.
 - a. Color: As selected by Architect from full range of industry colors.
- E. Stainless-Steel Finishes:
 1. Surface Preparation: Remove tool and die marks and stretch lines, or blend into finish.
 2. Polished Finish: No. 4 finish. Grind and polish surfaces to produce uniform finish, free of cross scratches.
 - a. Run grain of directional finishes with long dimension of each piece.
 - b. When polishing is completed, passivate and rinse surfaces. Remove embedded foreign matter and leave surfaces chemically clean.

PART 3 - EXECUTION

3.1 EXAMINATION

- A. Examine substrates for compliance with requirements for installation tolerances and other conditions affecting performance of the Work.
- B. Proceed with installation only after unsatisfactory conditions have been corrected.

3.2 INSTALLATION

- A. Comply with manufacturer's written instructions for installing access doors and frames.
- B. Install doors flush with adjacent finish surfaces or recessed to receive finish material.

3.3 FIELD QUALITY CONTROL

- A. Inspection Agency: Owner will engage a qualified inspector to perform inspections and to furnish reports to Architect.
- B. Inspections:
 1. Fire-Rated Door Inspections: Inspect each fire-rated access door in accordance with NFPA 80, section 5.2.
- C. Repair or remove and replace installations where inspections indicate that they do not comply with specified requirements.
- D. Reinspect repaired or replaced installations to determine if replaced or repaired door assembly installations comply with specified requirements.
- E. Prepare and submit separate inspection report for each fire-rated access door indicating compliance with each item listed in NFPA 80 and NFPA 101.

3.4 ADJUSTING

- A. Adjust doors and hardware after installation for proper operation.

END OF SECTION 083113

SECTION 084113

ALUMINUM-FRAMED ENTRANCES AND STOREFRONTS

PART 1 - GENERAL

1.1 SUMMARY

- A. Section Includes:
1. Aluminum-framed storefront systems.
 2. Aluminum-framed entrance door systems.

1.2 ADMINISTRATIVE REQUIREMENTS

- A. Preinstallation Meeting: Conduct meeting at Project site.
1. Convene meeting a minimum of 2 weeks prior to beginning Work of this Section.
 2. Require attendance by parties directly affecting Work of this Section. Review and discuss methods and procedures related to aluminum storefront and entrances including the following:
 3. Review and discuss methods and procedures related to aluminum-framed entrances and storefronts, including the following:
 - a. Finalize construction schedule and verify availability of materials, Installer's personnel, equipment, and facilities needed to perform Work and avoid delays.
 - b. Coordination of finishes of aluminum storefront and entrances with other aluminum framing systems that match color and finish.
 - c. Coordinate interrelationship of aluminum storefront with other exterior wall components. Include provisions for structural anchorage, glazing, flashing, weeping, sealants, and protection of finishes.
 - d. Sequence of Work required to construct a watertight and weathertight exterior building envelope.
 - e. Inspect and discuss condition of substrate and other preparatory Work performed by other trades.

1.3 ACTION SUBMITTALS

- A. Product Data: For each type of product.
1. Include construction details, material descriptions, glazing and fabrication methods, dimensions of individual components and profiles, internal drainage details, and finishes.
- B. Sustainable Design Submittals:
1. Environmental Product Declaration (EPD): For each product.
 2. Health Product Declaration (HPD): For each product.
 3. Product Data: For sealants, indicating VOC content.
 4. Laboratory Test Reports: For sealants, indicating compliance with requirements for low-emitting materials.
 5. Sourcing of Raw Materials: Corporate sustainability report for each manufacturer.
- C. Shop Drawings: For aluminum-framed entrances and storefronts. Include plans, elevations, sections, full-size details, and attachments to other Work.
1. Include details of provisions for assembly expansion and contraction and for draining moisture occurring within assembly to exterior.
 2. Include full-size isometric details of each type of vertical-to-horizontal intersection of aluminum-framed entrances and storefronts, showing the following:
 - a. Joinery, including concealed welds.
 - b. Anchorage.
 - c. Expansion provisions.

- d. Glazing.
 - e. Flashing and drainage.
 - 3. Show connection to and continuity with adjacent thermal, weather, air, and vapor barriers.
 - 4. Include point-to-point wiring diagrams showing the following:
 - a. Power requirements for each electrically operated door hardware.
 - b. Location and types of switches, signal device, conduit sizes, and number and size of wires.
 - 5. Submit Shop Drawings that have been engineered and certified by professional engineer licensed in the State of in which Project is located.
 - a. Include seal and signature of professional engineer on Shop Drawings.
- D. Samples for Verification: For each type of exposed finish required, in manufacturer's standard sizes.
- E. Fabrication Sample: Of each vertical-to-horizontal intersection of assemblies, fabricated from 12 inch lengths of full-size components and showing details of the following:
 - 1. Joinery, including concealed welds.
 - 2. Anchorage.
 - 3. Expansion provisions.
 - 4. Glazing.
 - 5. Flashing and drainage.
- F. Entrance Door Hardware Schedule: Prepared by or under supervision of supplier, detailing fabrication and assembly of entrance door hardware, as well as procedures and diagrams. Coordinate final entrance door hardware schedule with doors, frames, and related Work to ensure proper size, thickness, hand, function, and finish of entrance door hardware.
- G. Entrance Door Hardware Schedule: Coordinate and comply with requirements specified in Section 087100 – Door Hardware.

1.4 INFORMATIONAL SUBMITTALS

- A. Qualification Data:
 - 1. For Installer and field testing agency.
- B. Energy Performance Certificates: For aluminum-framed entrances and storefronts, accessories, and components, from manufacturer.
 - 1. Basis for Certification: NFRC-certified energy performance values for each aluminum-framed entrance and storefront.
- C. Product Test Reports: For aluminum-framed entrances and storefronts, for tests performed by manufacturer and witnessed by a qualified testing agency.
- D. Certification of ASHRAE 90.1 Fenestration Rating.
- E. Sample Warranties: For special warranties.

1.5 CLOSEOUT SUBMITTALS

- A. Maintenance Data: For aluminum-framed entrances and storefronts to include in maintenance manuals.

1.6 QUALITY ASSURANCE

- A. Manufacturer Qualifications: Manufacturer that specializes in manufacturing aluminum-framed entrances and storefronts comparable to systems specified for this Project with a minimum of 10 years of documented experience.

- B. Installer Qualifications: An entity that employs installers and supervisors who are trained and approved by manufacturer with a minimum of 10 years of documented experience installing aluminum-framed entrances and storefronts comparable to systems specified of this Project.
- C. Welder Qualifications: Qualify procedures and personnel according to the following:
 - 1. AWS D1.1, "Structural Welding Code - Steel."
 - 2. AWS D1.2, "Structural Welding Code - Aluminum."
 - 3. Use welders certified by AWS and State project is located for structural welding, and who have undergone recertification in the last 12 months.
- D. Product Options: Information on Drawings and in Specifications establishes requirements for aesthetic effects and performance characteristics of assemblies. Aesthetic effects are indicated by dimensions, arrangements, alignment, and profiles of components and assemblies as they relate to sightlines, to one another, and to adjoining construction.
 - 1. Do not change intended aesthetic effects, as judged solely by Architect, except with Architect's approval. If changes are proposed, submit comprehensive explanatory data to Architect for review.
- E. Mockups: Comply with requirements of Section 014339 – Mockups.
 - 1. Build mockups of typical wall area as shown on Drawings to verify selections made under Sample submittals and to demonstrate aesthetic effects, and to set quality standards for fabrication and installation.
 - 2. Notify Architect and Owner's representative a minimum of 7 days in advance of dates and times when in-place mockups will be constructed.
 - 3. Set unit in opening, glaze framing system, install flashing and joint sealants.
 - a. Examine flashing of openings prior to installing joint sealant.
 - 4. Perform testing on mockups according to requirements in "Field Quality Control" Article.
 - 5. Approval of mockups does not constitute approval of deviations from Contract Documents contained in mockups unless Architect specifically approves such deviations in writing.
 - 6. Obtain Architect's approval of mockups before continuing installation of aluminum-framed entrances and storefront.
 - 7. Subject to compliance with requirements, approved mockups may become part of completed Work if undisturbed at time of Substantial Completion.
 - 8. Maintain mockups during construction in an undisturbed condition as a standard for judging completed Work.

1.7 WARRANTY

- A. Special Warranty: Manufacturer agrees to repair or replace components of aluminum-framed systems that do not comply with requirements or that fail in materials or workmanship within specified warranty period.
 - 1. Failures include the following:
 - a. Structural failures including excessive deflection.
 - b. Noise or vibration created by wind and thermal and structural movements.
 - c. Deterioration of metals and other materials beyond normal weathering.
 - d. Water penetration through fixed glazing and framing areas.
 - e. Failure of operating components.
 - 2. Warranty Period: 5 years from date of Substantial Completion.
- B. Special Finish Warranty: Manufacturer agrees to repair finishes or replace aluminum that shows evidence of deterioration of factory-applied finishes within specified warranty period.
 - 1. Deterioration includes the following:
 - a. Color fading more than 5 Hunter units when tested according to ASTM D2244.
 - b. Chalking in excess of a No. 8 rating when tested according to ASTM D4214.
 - c. Cracking, checking, peeling, or failure of paint to adhere to bare metal.

2. Warranty Period: 5 years for anodized and 20 years for fluoropolymer from date of Substantial Completion.

PART 2 - PRODUCTS

2.1 MANUFACTURERS

- A. Basis-of-Design Product: Subject to compliance with requirements, provide products from one of the following:
 1. Thermally-Broken Aluminum Storefronts:
 - a. EFCO Corporation: XTherm Series 403X.
 - b. Kawneer Company Inc.: Trifab VG 451UT.
 - c. Manko Window Systems, Inc.: 2450 Series.
 - d. Oldcastle BuildingEnvelope: Series 3000 XT.
 - e. Tubelite, Inc.: TU24000 Dual Pocket Storefront Framing.
 - f. Approved substitution.
 2. Non-Thermally-Broken Aluminum Storefronts:
 - a. EFCO Corporation: XTherm Series 403X.
 - b. Kawneer Company Inc.: Trifab VG 450.
 - c. Manko Window Systems, Inc.: 2450 Series.
 - d. Oldcastle BuildingEnvelope: Series 3000 XT.
 - e. Tubelite, Inc.: TU24000 Dual Pocket Storefront Framing.
 - f. Approved substitution.
 3. Aluminum Entrances:
 - a. EFCO Corporation: ThermaStile Series D302 Medium Stile.
 - b. Kawneer Company Inc.: AA 425 Thermal Entrance.
 - c. Manko Window Systems, Inc.: 150i Series Medium Stile.
 - d. Oldcastle BuildingEnvelope: Model MS362T Series.
 - e. Tubelite, Inc.: Thermal=Block Entrance Series; Medium stile.
 - f. Approved substitution.
- B. Source Limitations: Obtain components of aluminum-framed entrance and storefront system, including framing, spandrel panels, entrances, and accessories, from single manufacturer
 1. Provide electrified door hardware from same manufacturer as mechanical door hardware unless otherwise indicated. Electrified modifications or enhancements made to a source manufacturer's product line by secondary or third party source will not be accepted.
 2. Provide standard door hardware and electrified hardware as a single sourced package from same qualified supplier.

2.2 PERFORMANCE CRITERIA

- A. General Performance: Comply with performance requirements specified, as determined by testing of aluminum-framed entrances and storefronts representing those indicated for this Project without failure due to defective manufacture, fabrication, installation, or other defects in construction.
 1. Aluminum-framed entrances and storefronts shall withstand movements of supporting structure, including story drift, twist, column shortening, long-term creep, and deflection, from uniformly distributed and concentrated live loads.
 2. Failure also includes the following:
 - a. Thermal stresses transferring to building structure.
 - b. Glass breakage.
 - c. Noise or vibration created by wind and thermal and structural movements.
 - d. Loosening or weakening of fasteners, attachments, and other components.
- B. Structural Loads:
 1. Wind and Other Loads: As indicated on Drawings.

- C. Deflection of Framing Members: At design wind pressure, as follows:
1. Deflection Normal to Wall Plane: Limited to edge of glass in a direction perpendicular to glass plane not exceeding $L/175$ of glass edge length for each individual glazing lite or an amount that restricts edge deflection of individual glazing lites to $3/4$ inch, whichever is less.
 2. Deflection Parallel to Glazing Plane: Limited to amount not exceeding that which reduces glazing bite to less than 75 percent of design dimension and that which reduces edge clearance between framing members and glazing or other fixed components directly below them to less than $1/8$ inch, unless dictated otherwise by seismic design requirements.
- D. Structural: Test according to ASTM E330 as follows:
1. When tested at positive and negative wind-load design pressures, assemblies do not evidence deflection exceeding specified limits.
 2. When tested at 150 percent of positive and negative wind-load design pressures, systems, including anchorage, do not evidence material failures, structural distress, and permanent deformation of main framing members exceeding 0.2 percent of span.
 3. Test Durations: As required by design wind velocity, but not less than 10 seconds.
- E. Water Penetration under Static Pressure: Test according to ASTM E331 as follows:
1. No evidence of water penetration through fixed glazing and framing areas, including entrance doors, when tested per a minimum static-air-pressure differential of 20 percent of positive wind-load design pressure, but not less than 8 lbf/sq. ft.
- F. Seismic Performance: Aluminum-framed entrances and storefronts shall withstand effects of earthquake motions determined according to ASCE 7.
- G. Energy Performance: Certified and labeled by manufacturer for energy performance as follows:
1. Thermal Transmittance (U-factor): U-factors as determined according to NFRC 100.
 - a. Fixed Glazing and Framing Areas: 0.37 Btu/sq. ft. x h x deg F.
 - b. Entrance Doors: 0.77 Btu/sq. ft. x h x deg F.
 - c. Operable Windows: Whole window U-factor of 0.26 Btu/sq. ft. x h x deg F.
 2. Solar Heat Gain Coefficient (SHGC): SHGC determined according to NFRC 200
 - a. Fixed Glazing and Framing Areas: SHGC for system of not more than 0.40 **[0.26] [0.35]**.
 - b. Entrance Doors: SHGC of not more than 0.40 **[0.26] [0.35]**.
 - c. Operable Windows: Whole window SHGC of not more than 0.40 **[0.26] [0.35]**.
- H. Air Leakage:
1. Fixed Glazing and Framing Areas: Maximum air leakage for system of 0.06 cfm/sq. ft. at static-air-pressure differential of 6.27 lbf/sq. ft. when tested according to ASTM E283.
 2. Entrance Doors: 1.0 cfm/sq. ft. at static-air-pressure differential of 1.57 lbf/sq. ft. when tested according to AAMA/WDMA/CSA 101/I.S.2/A440.
 3. Operable Windows: maximum whole window air leakage of 0.3 cfm/sq. ft. at static-air-pressure differential of 6.24 lbf/sq. ft. when tested according to AAMA/WDMA/CSA 101/I.S.2/A440.
- I. Condensation Resistance Factor (CRF): Determined according to AAMA 1503 or NFRC 500.
1. Fixed Glazing and Framing Areas: CRF for system of not less than 59.
 2. Entrance Doors: CRF of not less than 57.
 3. Operable Windows: Whole window CRF of not less than 52.
- J. Thermal Movements: Allow for thermal movements resulting from ambient and surface temperature changes.
1. Temperature Change: 120 deg F, ambient; 180 deg F, material surfaces.
 2. Thermal Cycling: No buckling; stress on glass; sealant failure; excess stress on framing, anchors, and fasteners; or reduction of performance when tested according to AAMA 501.5.
 - a. High Exterior Ambient-Air Temperature: That which produces an exterior metal-surface temperature of 180 deg F.
 - b. Low Exterior Ambient-Air Temperature: 0 deg F.
 - c. Interior Ambient-Air Temperature: 75 deg F.

2.3 ALUMINUM-FRAMED STOREFRONT SYSTEMS

- A. Framing Members: Manufacturer's extruded- or formed-aluminum framing members.
 - 1. Exterior Framing Construction: Thermally-broken.
 - 2. Interior Framing Construction: Nonthermal.
 - 3. Glazing System: Retained mechanically with gaskets on 4 sides.
 - 4. Glazing Plane: Center [**Front**] unless indicated otherwise.
 - 5. Framing Member Profile: 2 inch by 4-1/2 inch nominal dimension.
 - 6. Member Wall Thickness: Designed to meet structural performance requirements.
 - 7. Finish: Clear anodic finish [**Color anodic finish**] [**Baked-enamel or powder-coat finish**] [**High-performance organic finish**].
 - 8. Fabrication Method: Field-fabricated stick system.
 - 9. Aluminum: Alloy and temper recommended by manufacturer for type of use and finish indicated.
 - 10. Steel Reinforcement: As required by manufacturer to support imposed loads..
- B. Sill Pan: Extruded aluminum, factory-fabricated to provide sealed end dams, finished to match storefront; designed to direct water away from building when installed horizontally at sill. If manufacturer offers a similar sill pan as part of aluminum-framed entrance and storefront system, submit details and product data including finishes, for consideration and approved by Architect. PVC is not acceptable.
- C. Deflection Track: Manufacturer's standard thermally broken head deflection receptors sized for specified storefront framing system, finished to match framing.
 - 1. Design deflection track for minimum deflection of 3/4 inch.
- D. Backer Plates: Manufacturer's standard, continuous backer plates for framing members, if not integral, where framing abuts adjacent construction.
- E. Brackets and Reinforcements: Manufacturer's standard high-strength aluminum with nonstaining, nonferrous shims for aligning system components.
- F. Thermal Breaks: Window wall assemblies with manufacturer's typical thermal break construction consisting of one of the following:
 - 1. Polyurethane: 2-part chemically-curing, high-density polyurethane, mechanically and adhesively joined to aluminum framing sections.
 - a. Provide thermal break designed per AAMA TIR-A8 and tested per AAMA 505.
 - b. Minimum Thermal Separation: 1/2 inch.

2.4 ENTRANCE DOOR SYSTEMS

- A. Entrance Doors: Manufacturer's standard thermally-broken, heavy-duty, glazed entrance doors for manual swing or automatic operation.
 - 1. Door Construction: 2 to 2-1/4 inch overall thickness, with minimum 0.125 inch thick, extruded-aluminum tubular rail and stile members. Mechanically fasten corners with reinforcing brackets that are deeply penetrated and fillet welded or that incorporate concealed tie rods.
 - a. Thermal Construction: High-performance plastic connectors separate aluminum members exposed to exterior from members exposed to interior.
 - 2. Door Design: Medium stile; 3-1/2 inch nominal width.
 - 3. Glazing Stops and Gaskets: Square, snap-on, extruded-aluminum stops and preformed gaskets.
 - a. Provide nonremovable glazing stops on outside of door.

2.5 ENTRANCE DOOR HARDWARE

- A. Entrance Door Hardware: Hardware not specified in this Section is specified in Section 087100 – Door Hardware.

2.6 GLAZING

- A. Comply with Section 088000 – Glazing.
- B. Glazing Gaskets: ASTM C509 or ASTM C864.
 - 1. Manufacturer's standard non-shrinking, weather-resistant, compression-type, replaceable ethylene propylene diene monomer (EPDM).
 - 2. Color: Black, unless indicated otherwise].
- C. Glazing Sealants: As recommended by manufacturer and complying with Section 088000 – Glazing.
 - 1. Verify sealant has a VOC content of 250 g/L or less.
 - 2. Verify sealant complies with testing and product requirements of California Department of Public Health's "Standard Method for the Testing and Evaluation of Volatile Organic Chemical Emissions from Indoor Sources Using Environmental Chambers."

2.7 MATERIALS

- A. Aluminum:
 - 1. Sheet and Plate: ASTM B209.
 - 2. Extruded Bars, Rods, Profiles, and Tubes: ASTM B221.
 - 3. Structural Profiles: ASTM B308.
- B. Steel Reinforcement:
 - 1. Structural Shapes, Plates, and Bars: ASTM A36.
 - 2. Cold-Rolled Sheet and Strip: ASTM A1008.
 - 3. Hot-Rolled Sheet and Strip: ASTM A1011.
 - 4. Primer: Manufacturer's standard zinc-rich, corrosion-resistant primer complying with SSPC-PS Guide No. 12.00; applied immediately after surface preparation and pretreatment. Select surface preparation methods according to recommendations in SSPC-SP COM, and prepare surfaces according to applicable SSPC standard.
- C. Recycled Content of Aluminum Components: Postconsumer recycled content plus 1/2 half of preconsumer recycled content not less than 50 percent.

2.8 ACCESSORIES

- A. Automatic Door Operators: Section 087100 – Door Hardware.
- B. Fasteners and Accessories: Manufacturer's standard nonmagnetic stainless steel fasteners and accessories compatible with window members, trim, hardware, anchors, and other components.
 - 1. Use self-locking devices where fasteners are subject to loosening or turning out from thermal and structural movements, wind loads, or vibration.
 - 2. Reinforce members as required to receive fastener threads.
 - 3. Exposed Fasteners: Do not use exposed fasteners to greatest extent possible. Where exposed fasteners are unavoidable, provide exposed fasteners with countersunk Phillips screw heads, fabricated from 300 series stainless steel.
 - a. Where framing finish is other than clear anodized, finish exposed fasteners to match framing system.
- C. Anchors: 3-way adjustable anchors with minimum adjustment of 1 inch that accommodate fabrication and installation tolerances in material and finish compatible with adjoining materials and recommended by manufacturer.
 - 1. Concrete and Masonry Inserts: Hot-dip galvanized cast-iron, malleable-iron, or steel inserts complying with ASTM A123 or ASTM A153 requirements.

- D. Flashing:
 - 1. Exposed: 0.032 inch thick aluminum sheet; ASTM B209, finish to match framing members.
 - 2. Concealed: Dead-soft, 0.018 inch thick stainless steel, ASTM A240 of type recommended by manufacturer.
- E. Bituminous Paint: Cold-applied asphalt-mastic paint containing no asbestos, formulated for 30 mil thickness per coat.

2.9 FABRICATION

- A. Form or extrude aluminum shapes before finishing.
- B. Weld in concealed locations to greatest extent possible to minimize distortion or discoloration of finish. Remove weld spatter and welding oxides from exposed surfaces by descaling or grinding.
- C. Fabricate components that, when assembled, have the following characteristics:
 - 1. Profiles that are sharp, straight, and free of defects or deformations.
 - 2. Accurately fitted joints with ends coped or mitered.
 - 3. Physical and thermal isolation of glazing from framing members.
 - 4. Accommodations for thermal and mechanical movements of glazing and framing to maintain required glazing edge clearances.
 - 5. Provisions for field replacement of glazing from interior for vision glass and exterior for spandrel glazing or metal panels.
 - 6. Fasteners, anchors, and connection devices that are concealed from view to greatest extent possible.
- D. Mechanically Glazed Framing Members: Fabricate for flush glazing without projecting stops.
- E. Storefront Framing: Fabricate components for assembly using shear-block or screw-spline system.
- F. Entrance Door Frames: Reinforce as required to support loads imposed by door operation and for installing entrance door hardware.
 - 1. At exterior doors, provide compression weatherstripping at fixed stops.
- G. Entrance Doors: Reinforce doors as required for installing entrance door hardware.
 - 1. At pairs of exterior doors, provide weatherstripping retained in adjustable strip and mortised into door edge.
 - 2. At exterior doors, provide weather sweeps applied to door bottoms.
- H. Entrance Door Hardware Installation: Factory install entrance door hardware to greatest extent possible. Cut, drill, and tap for factory-installed entrance door hardware before applying finishes.
- I. After fabrication, clearly mark components to identify their locations in Project according to Shop Drawings.

2.10 ALUMINUM FINISHES

- A. Finish designations prefixed by AA comply with system established by Aluminum Association for designating aluminum finishes.
- B. Clear Anodic Finish: AAMA 611, AA-M12C22A41, Class I, 0.018 mm or thicker.
- C. Color Anodic Finish: AAMA 611, AA-M12C22A42/A44, Class I, 0.018 mm or thicker.
 - 1. Color: As indicated on Drawings.

- D. Superior-Performance Organic Finish, 3-Coat PVDF: Fluoropolymer finish complying with AAMA 2605 and containing not less than 70 percent PVDF resin by weight in both color coat and clear topcoat
 - 1. Prepare, pretreat, and apply coating to exposed metal surfaces to comply with coating and resin manufacturers' written instructions.
 - 2. Color: As indicated on Drawings.
- E. Concealed Steel Items: Prime with iron oxide paint.
- F. Liquid Strippable Coating: Apply in shop to prefinished surfaces to protect finish during fabrication, shipping, and field handling.

PART 3 - EXECUTION

3.1 EXAMINATION

- A. Examine areas, with Installer present, for compliance with requirements for installation tolerances and other conditions affecting performance of Work.
- B. Proceed with installation only after unsatisfactory conditions have been corrected.

3.2 INSTALLATION, GENERAL

- A. Comply with manufacturer's written instructions.
- B. Do not install damaged components.
- C. Fit joints to produce hairline joints free of burrs and distortion.
- D. Rigidly secure nonmovement joints.
- E. Install anchors with separators and isolators to prevent metal corrosion and electrolytic deterioration and to prevent impeding movement of moving joints.
- F. Seal perimeter and other joints watertight unless otherwise indicated.
- G. Metal Protection:
 - 1. Where aluminum is in contact with dissimilar metals, protect against galvanic action by painting contact surfaces with materials recommended by manufacturer for this purpose or by installing nonconductive spacers.
 - 2. Where aluminum is in contact with concrete or masonry, protect against corrosion by painting contact surfaces with bituminous paint.
- H. Set continuous sill members and flashing in full sealant bed, as specified in Section 079200 – Joint Sealants, to produce weathertight installation.
- I. Install components plumb and true in alignment with established lines and grades.

3.3 INSTALLATION OF OPERABLE UNITS

- A. Install operable units level and plumb, securely anchored, and without distortion. Adjust weatherstripping contact and hardware movement to produce proper operation.

3.4 INSTALLATION OF GLAZING

- A. Install glazing as specified in Section 088000 – Glazing.

3.5 INSTALLATION OF WEATHERSEAL SEALANT

- A. After structural sealant has completely cured, remove temporary retainers and insert backer rod between lites of glass as recommended by sealant manufacturer.
- B. Install weatherseal sealant, according to Section 079200 – Joint Sealants, to completely fill cavity, according to sealant manufacturer's written instructions, to produce weatherproof joints.

3.6 INSTALLATION OF ALUMINUM-FRAMED ENTRANCE DOORS

- A. Entrance Doors: Install doors to produce smooth operation and tight fit at contact points.
 - 1. Exterior Doors: Install to produce weathertight enclosure and tight fit at weatherstripping.
 - 2. Field-Installed Entrance Door Hardware: Install surface-mounted entrance door hardware according to entrance door hardware manufacturers' written instructions using concealed fasteners to greatest extent possible.

3.7 ERECTION TOLERANCES

- A. Erection Tolerances: Install aluminum-framed entrances and storefronts to comply with the following maximum tolerances:
 - 1. Plumb: 1/8 inch in 10 feet; 1/4 inch in 40 feet.
 - 2. Level: 1/8 inch in 20 feet; 1/4 inch in 40 feet.
 - 3. Alignment:
 - a. Where surfaces abut in line or are separated by reveal or protruding element up to 1/2 inch wide, limit offset from true alignment to 1/16 inch.
 - b. Where surfaces are separated by reveal or protruding element from 1/2 to 1 inch wide, limit offset from true alignment to 1/8 inch.
 - c. Where surfaces are separated by reveal or protruding element of 1 inch wide or more, limit offset from true alignment to 1/4 inch.
 - 4. Location: Limit variation from plane to 1/8 inch in 12 feet; 1/2 inch over total length.

3.8 FIELD QUALITY CONTROL

- A. Testing Agency: Owner will engage a qualified testing agency to perform tests and inspections.
- B. Field Quality-Control Testing: Perform the following tests on representative areas of aluminum-framed entrances and storefronts to determine compliance of installed systems with specified requirements.
 - 1. Do not proceed with installation of next area until test results for previously completed areas show compliance with requirements.
 - 2. Water-Spray Test: Before installation of interior finishes has begun, areas designated by Architect shall be tested according to AAMA 501.2 and shall not evidence water penetration.
 - a. Perform a minimum of 4 tests in areas as directed by Architect.
 - b. Perform tests at pressure indicated in Performance Criteria Article.
 - 3. Air Leakage: ASTM E783 at 1.5 times the rate specified for laboratory testing in "Performance Requirements" Article, but not more than 0.09 cfm/sq. ft. at a static-air-pressure differential of 1.57 lbf/sq. ft.
 - a. Perform a minimum of 4 tests in areas as directed by Architect.
 - 4. Water Penetration: ASTM E1105 at full uniform and cyclic static-air-pressure specified for laboratory testing in "Performance Requirements" Article, but not less than 6.24 lbf/sq. ft., and shall not evidence water penetration.
- C. Aluminum-framed entrances and storefronts will be considered defective if they do not pass tests and inspections.
- D. Prepare test and inspection reports.

3.9 ADJUSTING

- A. Adjust operating sashes and hardware for a tight fit at contact points and weatherstripping for smooth operation and weathertight closure.

3.10 CLEANING

- A. Clean exposed surfaces immediately after installing windows. Avoid damaging protective coatings and finishes. Remove excess sealants, glazing materials, dirt, and other substances.
 - 1. Keep protective films and coverings in place until final cleaning.
- B. Remove and replace glass that has been broken, chipped, cracked, abraded, or damaged during construction period.

3.11 PROTECTION

- A. Protect window surfaces from contact with contaminating substances resulting from construction operations. If contaminating substances do contact window surfaces, remove contaminants immediately according to manufacturer's written instructions.

3.12 MAINTENANCE SERVICE

- A. Entrance Door Hardware:
 - 1. Maintenance Tools and Instructions: Furnish a complete set of specialized tools and maintenance instructions as needed for Owner's continued adjustment, maintenance, and removal and replacement of entrance door hardware.
 - 2. Initial Maintenance Service: Beginning at Substantial Completion, provide 6 months' full maintenance by skilled employees of entrance door hardware Installer. Include quarterly preventive maintenance, repair or replacement of worn or defective components, lubrication, cleaning, and adjusting as required for proper entrance door hardware operation at rated speed and capacity. Use parts and supplies that are the same as those used in manufacture and installation of original equipment.

END OF SECTION 084113

SECTION 085313
VINYL WINDOWS AND DOORS

PART 1 - GENERAL

1.1 SUMMARY

- A. Section Includes:
1. Vinyl-framed windows.
 2. Vinyl-framed doors.

1.2 ADMINISTRATIVE REQUIREMENTS

- A. Preinstallation Meeting: Conduct meeting at Project Site.
1. Review and finalize construction schedule and verify availability of materials, Installer's personnel, equipment, and facilities needed to make progress and avoid delays.
 2. Review, discuss, and coordinate interrelationship of vinyl windows and doors with other exterior wall components. Include provisions for anchoring, flashing, weeping, sealing perimeters, and protecting finishes.
 3. Review and discuss sequence of Work required to construct a watertight and weathertight exterior building envelope.
 4. Inspect and discuss condition of substrate and other preparatory Work performed by other trades.

1.3 ACTION SUBMITTALS

- A. Product Data: For each type of product.
1. Include construction details, material descriptions, glazing and fabrication methods, dimensions of individual components and profiles, hardware, and finishes.
- B. Shop Drawings:
1. Include plans, elevations, sections, hardware, accessories, insect screens, operational clearances, and details of installation, including anchor, flashing, and sealant installation.
- C. Samples for Verification: For fiberglass windows, doors, and components required, prepared on Samples of size indicated below:
1. Main Framing Member: 12 inch long, full-size sections of extrusions with factory-applied color finish.
 2. Corner Fabrication: 12 by 12 inch long, full-size corner including full-size sections of extrusions with factory-applied color finish, weatherstripping, and glazing.
 3. Exposed Finishes: 2 by 4 inch.
 4. Operable Window: Full-size unit with factory-applied finish.
 5. Hardware: 2 full-size units with factory-applied finishes.
 6. Weatherstripping: 12 inch long sections.
- D. Product Schedule: For vinyl windows and doors. Use same designations indicated on Drawings.

1.4 INFORMATIONAL SUBMITTALS

- A. Qualification Data: For manufacturer and Installer.
- B. Product Test Reports: For each type of vinyl window, for tests performed by a qualified testing agency.
- C. Sample Warranties: For manufacturer's warranties.

1.5 QUALITY ASSURANCE

- A. Manufacturer Qualifications: A manufacturer capable of fabricating vinyl windows and doors that meet or exceed performance requirements indicated and of documenting this performance by test reports and calculations.
- B. Installer Qualifications: An installer acceptable to vinyl window manufacturer for installation of units required for this Project.
- C. Mockups: Build mockups to verify selections made under Sample submittals, to demonstrate aesthetic effects, and to set quality standards for materials and execution.
 - 1. Build mockup of typical wall area as shown on Drawings.
 - 2. Approval of mockups does not constitute approval of deviations from Contract Documents contained in mockups unless Architect specifically approves such deviations in writing.
 - 3. Subject to compliance with requirements, approved mockups may become part of completed Work if undisturbed at time of Substantial Completion.

1.6 WARRANTY

- A. Manufacturer's Warranty: Manufacturer agrees to repair or replace vinyl windows and doors that fail in materials or workmanship within specified warranty period.
 - 1. Failures include the following:
 - a. Failure to meet performance requirements.
 - b. Structural failures including excessive deflection, water leakage, and air infiltration.
 - c. Faulty operation of movable sash and hardware.
 - d. Deterioration of materials and finishes beyond normal weathering.
 - e. Failure of insulating glass.
 - 2. Warranty Periods: from date of Substantial Completion.
 - a. Frames and Hardware: 10 years.
 - b. Glazing Units:
 - 1) Insulated Glazing Units: 10 years.
 - 2) Monolithic Glazing Units: 5 years.

PART 2 - PRODUCTS

2.1 MANUFACTURERS

- A. Basis-of-Design Product: Subject to compliance with requirements, provide the following:
 - 1. VPI Quality Windows, Inc.: Endurance Series 510.
 - 2. Approved substitution from one of the following:
 - a. Drutex: IGLO 5 Classic.
 - b. Approved substitution.
- B. Source Limitations: Obtain vinyl windows and doors from single source from single manufacturer.

2.2 PERFORMANCE CRITERIA

- A. Product Standard: Comply with AAMA/WDMA/CSA 101/I.S.2/A440 for definitions and minimum standards of performance, materials, components, accessories, and fabrication unless more stringent requirements are indicated.
 - 1. Window Certification: WDMA certified with label attached to each window.
- B. Performance Class and Grade: AAMA/WDMA/CSA 101/I.S.2/A440 as follows:
 - 1. Minimum Performance Class: LC or CW.
 - 2. Minimum Performance Grade:
 - a. Sliding Units: 25.

- b. Fixed/Casement/Awning Units: 30.
- C. Thermal Transmittance: NFRC 100 maximum whole-window U-factor of 0.26 Btu/sq. ft. x h x deg F.
- D. Solar Heat-Gain Coefficient (SHGC): NFRC 200 maximum whole-window SHGC as follows:
 - 1. Casement/Awning: 0.18.
 - 2. Fixed: 0.22.
 - 3. Sliding: 0.22.
- E. Sound Transmission Class (STC): Rated for not less than the following STC when tested for laboratory sound transmission loss according to ASTM E90 and determined by ASTM E413.
 - 1. Casement/Awning: 0.36.
 - 2. Fixed: 0.38.
 - 3. Sliding: 0.36.
- F. Outside-Inside Transmission Class (OITC): Rated for not less than the following OITC when tested for laboratory sound transmission loss according to ASTM E90 and determined by ASTM E1332.
 - 1. Casement/Awning: 0.30.
 - 2. Fixed: 0.29.
 - 3. Sliding: 0.29.

2.3 VINYL WINDOWS AND DOORS

- A. Operating Types: Provide operating types indicated on Drawings:
- B. Frames and Sashes: Extruded, hollow, impact-resistant, and UV-stabilized PVC complying with AAMA/WDMA/CSA 101/I.S.2/A440.
 - 1. Integral Colors:
 - a. Exterior: Color as indicated on Drawings.
 - b. Interior: Matching exterior color and finish.
- C. Glass and Glazing Materials: Comply with requirements of Section 088000 – Glazing.
- D. Glass: Clear annealed glass, ASTM C1036, Type 1, Class 1, q3.
 - 1. Kind: Fully tempered where indicated on Drawings.
- E. Insulating-Glass Units: ASTM E2190.
 - 1. Glass: ASTM C 1036, Type 1, Class 1, q3.
 - a. Tint: Clear.
 - b. Kind: Fully tempered where indicated on Drawings.
 - 2. Lites: 2.
 - 3. Interspace Content: Fill space between glass lites with argon.
 - 4. Low-E Coating: Pyrolytic or sputtered on second surface.
- F. Glazing System: Manufacturer's standard factory-glazing system that produces weathertight seal.
- G. Hardware, General: Provide manufacturer's standard hardware fabricated from aluminum, stainless steel, carbon steel complying with AAMA 907, or other corrosion-resistant material compatible with adjacent materials; designed to smoothly operate, tightly close, and securely lock windows and doors, and sized to accommodate sash weight and dimensions.
 - 1. Exposed Hardware Color and Finish: As selected by Architect from manufacturer's full range.
- H. Projected Window Hardware:
 - 1. Gear-Type Rotary Operators: Complying with AAMA 901 when tested according to ASTM E405, Method A. Provide operators that function without requiring removal of interior screens or using screen wickets.
 - a. Type and Style: As selected by Architect from manufacturer's full range of types and styles.

2. Hinges: Manufacturer's standard type for sash weight and size indicated.
3. Single-Handle Locking System: Operates positive-acting arms that pull sash into locked position. Provide one arm on sashes up to 29 inches tall and 2 arms on taller sashes.
4. Limit Devices: Manufacturer's standard limit devices designed to restrict sash opening.
 - a. Limit clear opening to 4 inches for ventilation; with custodial key release.
- I. Weatherstripping: Provide full-perimeter weatherstripping for each operable sash and door unless otherwise indicated.
- J. Fasteners: Noncorrosive and compatible with window and door members, trim, hardware, anchors, and other components.
 1. Exposed Fasteners: Do not use exposed fasteners to greatest extent possible. For application of hardware, use fasteners that match finish hardware being fastened.

2.4 ACCESSORIES

- A. Integral Ventilating Device (Trickle Vent): Where indicated, provide weatherstripped, adjustable, horizontal fresh-air vent, with a free airflow slot, complying with AAMA/WDMA/CSA 101/I.S.2/A440. Equip vent bar with an integral insect screen, removable for cleaning.
 1. Airflow Slot: Approximately 1 inch high by full width of window sash when open.
 2. Locations: Provide minimum of 1 trickle vent per frame or as indicated on Drawings.

2.5 INSECT SCREENS

- A. General: Fabricate insect screens to integrate with window frame. Provide screen for each operable exterior sash. Screen wickets are not permitted.
 1. Type and Location: Full, inside for project-out; full, outside for project-in sashes.
- B. Aluminum Frames: Manufacturer's standard aluminum alloy complying with SMA 1004 or SMA 1201. Fabricate frames with mitered or coped joints or corner extrusions, concealed fasteners, and removable PVC spline/anchor concealing edge of frame.
 1. Tubular Framing Sections and Cross Braces: Roll formed from aluminum sheet.
 2. Finish for Screens: Matching color and finish of adjacent window frames and sashes.

2.6 FABRICATION

- A. Factory-fabricate vinyl windows and doors in sizes indicated. Include a complete system for installing and anchoring windows and doors.
- B. Factory-glaze vinyl windows and doors.
- C. Weatherstrip each operable sash and door to provide weathertight installation.
- D. Hardware: Mount hardware through double walls of vinyl extrusions or provide corrosion-resistant reinforcement.
- E. Complete fabrication, assembly, finishing, hardware application, and other Work in factory to greatest extent possible. Disassemble components only as necessary for shipment and installation. Allow for scribing, trimming, and fitting at Project site.

PART 3 - EXECUTION

3.1 EXAMINATION

- A. Examine openings, substrates, structural support, anchorage, and conditions, with Installer present, for compliance with requirements for installation tolerances and other conditions affecting performance of Work.

- B. Verify rough opening dimensions, levelness of sill plate, and operational clearances.
- C. Examine wall flashings, vapor retarders, water and weather barriers, and other built-in components to ensure weathertight window installation.
- D. Proceed with installation only after unsatisfactory conditions have been corrected.

3.2 INSTALLATION

- A. Comply with manufacturer's written instructions for installing windows, doors, hardware, accessories, and other components. For installation procedures and requirements not addressed in manufacturer's written instructions, comply with installation requirements in ASTM E2112.
- B. Install windows and doors level, plumb, square, true to line, without distortion, anchored securely in place to structural support, and in proper relation to wall flashing and other adjacent construction to produce weathertight construction.
- C. Install windows, doors, and components to drain condensation, water penetrating joints, and moisture migrating within windows and doors to exterior.

3.3 FIELD QUALITY CONTROL

- A. Testing Agency: Owner will engage a qualified testing agency to perform tests and inspections.
 - 1. Testing and inspecting agency will interpret tests and state in each report whether tested work complies with or deviates from requirements.
- B. Testing Services: Testing and inspecting of installed windows and doors shall take place as follows:
 - 1. Testing Methodology: Testing of windows and doors for air infiltration and water resistance shall be performed according to AAMA 502.
 - 2. Air-Infiltration Testing:
 - a. Test Pressure: That required to determine compliance with AAMA/WDMA/CSA 101/I.S.2/A440 performance class indicated.
 - b. Allowable Air-Leakage Rate: 1.5 times applicable AAMA/WDMA/CSA 101/I.S.2/A440 rate for product type and performance class rounded down to 1 decimal place.
 - 3. Water-Resistance Testing:
 - a. Test Pressure: 2/3 times test pressure required to determine compliance with AAMA/WDMA/CSA 101/I.S.2/A440 performance grade indicated.
 - b. Allowable Water Infiltration: No water penetration.
 - 4. Testing Extent: 3 windows and doors of each type as selected by Architect and a qualified independent testing and inspecting agency. Windows and doors shall be tested after perimeter sealants have cured.
 - 5. Test Reports: Prepared according to AAMA 502.
- C. Windows and doors will be considered defective if they do not pass tests and inspections.
- D. Prepare test and inspection reports.

3.4 ADJUSTING

- A. Adjust operating sashes and hardware for a tight fit at contact points and weatherstripping for smooth operation and weathertight closure.

3.5 CLEANING

- A. Clean exposed surfaces immediately after installing windows and doors. Remove excess sealants, glazing materials, dirt, and other substances.
 - 1. Keep protective films and coverings in place until final cleaning.
- B. Remove and replace sashes if glass has been broken, chipped, cracked, abraded, or damaged during construction period.

3.6 PROTECTION

- A. Protect window surfaces from contact with contaminating substances resulting from construction operations. If contaminating substances do contact window surfaces, remove contaminants immediately according to manufacturer's written instructions.

END OF SECTION 085313

SECTION 087100
DOOR HARDWARE

PART 1 - GENERAL

1.1 SUMMARY:

A. Section Includes:

1. Finish Hardware for door openings, except as otherwise specified herein.
2. Door hardware for steel (hollow metal) doors.
3. Door hardware for aluminum doors.
4. Door hardware for wood doors.
5. Door hardware for other doors indicated.
6. Keyed cylinders as indicated.

B. Related Sections:

1. Division 6: Rough Carpentry.
2. Division 8: Aluminum Doors and Frames
3. Division 8: Hollow Metal Doors and Frames.
4. Division 8: Wood Doors.
5. Division 26 Electrical
6. Division 28: Electronic Security

C. References: Comply with applicable requirements of the following standards. Where these standards conflict with other specific requirements, the most restrictive shall govern.

1. Builders Hardware Manufacturing Association (BHMA)
2. NFPA 101 Life Safety Code
3. NFPA 80 -Fire Doors and Windows
4. ANSI-A156.xx- Various Performance Standards for Finish Hardware
5. UL10C – Positive Pressure Fire Test of Door Assemblies
6. ANSI-A117.1 – Accessible and Usable Buildings and Facilities
7. DHI /ANSI A115.IG – Installation Guide for Doors and Hardware
8. ICC – International Building Code

D. Intent of Hardware Groups

1. Should items of hardware not definitely specified be required for completion of the Work, furnish such items of type and quality comparable to adjacent hardware and appropriate for service required.
2. Where items of hardware aren't definitely or correctly specified, are required for completion of the Work, a written statement of such omission, error, or other discrepancy to be submitted to Architect, prior to date specified for receipt of bids for clarification by addendum; or, furnish such items in the type and quality established by this specification, and appropriate to the service intended.

E. Alternates

1. Refer to Division 1 for Alternates and procedures.

1.2 ACTION SUBMITTALS

A. Special Submittal Requirements:

1. Combine submittals of this Section with Sections listed below to ensure "design intent" of system/assembly is understood and can be reviewed together.

B. Product Data: Manufacturer's specifications and technical data including the following:

1. Detailed specification of construction and fabrication.
2. Manufacturer's installation instructions.
3. Wiring diagrams for each electric product specified. Coordinate voltage with electrical before submitting.
4. Submit 6 copies of catalog cuts with hardware schedule.
5. Provide 9001-Quality Management and 14001-Environmental Management for products listed in Materials Section 2.2

C. Shop Drawings - Hardware Schedule: Submit 6 complete reproducible copy of detailed hardware schedule in a vertical format.

1. List groups and suffixes in proper sequence.
2. Completely describe door and list architectural door number.
3. Manufacturer, product name, and catalog number.
4. Function, type, and style.
5. Size and finish of each item.
6. Mounting heights.
7. Explanation of abbreviations and symbols used within schedule.
8. Detailed wiring diagrams, specially developed for each opening, indicating all electric hardware, security equipment and access control equipment, and door and frame rough-ins required for specific opening.

D. Templates: Submit templates and "reviewed Hardware Schedule" to door and frame supplier and others as applicable to enable proper and accurate sizing and locations of cutouts and reinforcing.

1. Templates, wiring diagrams and "reviewed Hardware Schedule" of electrical terms to electrical for coordination and verification of voltages and locations.

E. Samples: Provide the following if requested by Architect.

1. 1 Sample of Lever and Rose/Escutcheon design, (pair).
2. 3 Samples of metal finishes

1.3 CLOSEOUT SUBMITTALS

A. Contract Closeout Submittals: Comply with Division 1 including specific requirements indicated.

1. Operating and maintenance manuals: Submit 3 sets containing the following.
 - a. Complete information in care, maintenance, and adjustment, and data on repair and replacement parts, and information on preservation of finishes.
 - b. Catalog pages for each product.
 - c. Name, address, and phone number of local representative for each manufacturer.
 - d. Parts list for each product.
2. Copy of final hardware schedule, edited to reflect, "As installed".
3. Copy of final keying schedule
4. As installed "Wiring Diagrams" for each piece of hardware connected to power, both low voltage and 110 volts.
5. One set of special tools required for maintenance and adjustment of hardware, including changing of cylinders.

1.4 QUALITY ASSURANCE

- A. Comply with Division 1.
 - 1. Statement of qualification for distributor and installers.
 - 2. Statement of compliance with regulatory requirements and single source responsibility.
 - 3. Distributor's Qualifications: Firm with 3 years of experience in distribution of commercial hardware.
 - a. Distributor to employ full time Architectural Hardware Consultants (AHC) for the purpose of scheduling and coordinating hardware and establishing keying schedule.
 - b. Hardware Schedule shall be prepared and signed by an AHC.
 - 4. Installer's Qualifications: Firm with 3 years experienced in installation of similar hardware to that required for this Project, including specific requirements indicated.
 - 5. Regulatory Label Requirements: Provide testing agency label or stamp on hardware for labeled openings.
 - a. Provide UL listed hardware for labeled and 20 minute openings in conformance with requirements for class of opening scheduled.
 - b. Underwriters Laboratories requirements have precedence over this specification where conflict exists.
 - 6. Single Source Responsibility: Except where specified in hardware schedule, furnish products of only one manufacturer for each type of hardware.
- B. Review Project for extent of finish hardware required to complete the Work. Where there is a conflict between these Specifications and the existing hardware, notify the Architect in writing and furnish hardware in compliance with the Specification unless otherwise directed in writing by the Architect.

1.5 DELIVERY, STORAGE, AND HANDLING

- A. Packing and Shipping: Comply with Division 1.
 - 1. Deliver products in original unopened packaging with legible manufacturer's identification.
 - 2. Package hardware to prevent damage during transit and storage.
 - 3. Mark hardware to correspond with "reviewed hardware schedule".
 - 4. Deliver hardware to door and frame manufacturer upon request.
- B. Storage and Protection: Comply with manufacturer's recommendations.

1.6 PROJECT CONDITIONS:

- A. Coordinate hardware with other work. Furnish hardware items of proper design for use on doors and frames of the thickness, profile, swing, security and similar requirements indicated, as necessary for the proper installation and function, regardless of omissions or conflicts in the information on the Contract Documents.
- B. Review Shop Drawings for doors and entrances to confirm that adequate provisions will be made for the proper installation of hardware.

1.7 WARRANTY:

- A. Manufacturer's Warranty:
 - 1. Closers: Twenty-Five years
 - 2. Exit Devices: Five Years
 - 3. Locksets & Cylinders: Three years
 - 4. All other Hardware: Two years.

1.8 MAINTENANCE:

- A. Extra Service Materials: Deliver to Owner extra materials from same production run as products installed. Package products with protective covering and identify with descriptive labels. Comply with Division 1 Closeout Submittals Section.
 - 1. Special Tools: Provide special wrenches and tools applicable to each different or special hardware component.
 - 2. Maintenance Tools: Provide maintenance tools and accessories supplied by hardware component manufacturer.
 - 3. Delivery, Storage and Protection: Comply with Owner's requirements for delivery, storage and protection of extra service materials.

- B. Maintenance Service: Submit for Owner's consideration maintenance service agreement for electronic products installed.

PART 2 - PRODUCTS

2.1 MANUFACTURERS:

The following manufacturers are approved subject to compliance with requirements of the Contract Documents. Approval of manufacturers other than those listed shall be in accordance with Division 1.

<u>Item:</u>	<u>Manufacturer:</u>	<u>Approved:</u>
Hinges	Stanley	Bommer, PBB
Continuous Hinges	Stanley	Select, ABH
Locksets	Dorma	Stanley, Schlage
Unit RFID locks	Schlage	No substitution
Cylinders	Dorma	Stanley, Schlage
Unit Interiors	Falcon	Stanley, Schlage
Exit Devices	Dorma	Precision , Von Duprin,
Closers	Dorma	Stanley QDC, Norton 7500
Protection Plates	Trimco	Don Jo, Rockwood
Door Stops	Trimco	Don Jo, Rockwood
Flush Bolts	Trimco	Don Jo, Rockwood
Coordinator & Brackets	Trimco	Don Jo, Rockwood
Threshold & Gasketing	Pemko	National Guard, K.N. Crowder

2.2 MATERIALS:

- A. Hinges: Shall be Five Knuckle Ball bearing hinges
 - 1. Template screw hole locations
 - 2. Bearings are to be fully hardened.
 - 3. Bearing shell is to be consistent shape with barrel.
 - 4. Minimum of 2 permanently lubricated non-detachable bearings on standard weight hinge and 4 permanently lubricated bearing on heavy weight hinges.
 - 5. Equip with easily seated, non-rising pins.
 - 6. Non Removable Pin screws shall be slotted stainless steel screws.
 - 7. Hinges shall be full polished, front, back and barrel.
 - 8. Hinge pin is to be fully plated.
 - 9. Bearing assembly is to be installed after plating.
 - 10. Sufficient size to allow 180-degree swing of door
 - 11. Furnish five knuckles with flush ball bearings
 - 12. Provide hinge type as listed in schedule.
 - 13. Furnish 3 hinges per leaf to 7 foot 6 inch height. Add one for each additional 30 inches in height or fraction thereof.

14. Tested and approved by BHMA for all applicable ANSI Standards for type, size, function and finish
 15. UL10C listed for Fire rated doors.
- B. Geared Continuous Hinges:
1. Tested and approved by BHMA for ANSI A156.26-1996 Grade 1
 2. Anti-spinning through fastener
 3. UL10C listed for 3 hour Fire rating
 4. Non-handed
 5. Lifetime warranty
 6. Provide Fire Pins for 3-hour fire ratings
 7. Sufficient size to permit door to swing 180 degrees
- C. Cylindrical Grade 2 Type Locks and Latchsets:
1. Certified by BHMA for ANSI A156.3, Series 4000, Operational Grade 2.
 2. Fit modified ANSI A115.3 door preparation
 3. Locksets and cores to be of the same manufacturer to maintain complete lockset warranty
 4. 2-3/4 inch (70mm) backset, or 2 3/8 inch backset as needed
 5. 1/2 inch (14mm) throw latchbolt
 6. Provide locksets with 6-pin core.
 7. Functions and design as indicated in the hardware groups
- D. Mechanical Deadbolt:
1. ANSI/BHMA A156.36 Grade 2 certified and listed
 2. ANSI A117.1 Accessibility Code (ADA) compliant
 3. UL/cUL listed for up to 3 hours "A" label doors
 4. UL10C/UBC7 positive pressure rated
 5. Backset adjustable: 2-3/8" or 2-3/4"
 6. Door Thickness: 1-3/8" to 1-3/4" standard
 7. Door prep: 2-1/8" diameter cross bore
 8. Latch bolt: 1" throw tapered latch bolt with hardened steel roller (adjustable) -
 9. Latch face plate: Round and square corner latch face plates included.
 10. Strike: Round and square corner deadbolt strikes included.
 11. Keyway options: BEST "F", Schlage C, Kwikset
 12. Finish options: 605, 619, 716, 625, 626 and simulated 613
 13. Escutcheon: Standard (round) stamped steel, Classic (square) and Decorative (traditional) pressure cast zinc.
 14. Warranty: Lifetime mechanical, 3 year finish (except 613).
- E. Exit Devices shall:
1. Tested and approved by BHMA for ANSI 156.3, Grade 1
 2. Provide 9001-Quality Management and 14001-Environmental Management.
 3. Furnish UL or recognized independent laboratory certified mechanical operational testing to 10 million cycles minimum.
 4. Provide a deadlocking latchbolt
 5. Non-fire rated exit devices shall have cylinder dogging.
 6. Touchpad shall be "T" style
 7. Exposed components shall be of architectural metals and finishes.
 8. Lever design shall match lockset lever design
 9. Provide strikes as required by application.
 10. Fire exit devices to be listed for UL10C
 11. UL listed for Accident Hazard
 12. Shall consist of a cross bar or push pad, the actuating portion of which extends across, shall not be less than one half the width of the door leaf.

13. Provide vandal resistant or breakaway trim
 14. Aluminum vertical rod assemblies are acceptable only when provide with the manufacturers optional top and bottom stainless steel rod guard protectors.
- F. Door Closers shall:
1. Tested and approved by BHMA for ANSI 156.4, Grade 1
 2. UL10C certified
 3. Provide 9001-Quality Management and 14001-Environmental Management.
 4. Closer shall have extra-duty arms and knuckles
 5. Conform to ANSI 117.1
 6. Maximum 2 7/16 inch case projection with non-ferrous cover
 7. Separate adjusting valves for closing and latching speed, and backcheck
 8. Provide adapter plates, shim spacers and blade stop spacers as required by frame and door conditions
 9. Full rack and pinion type closer with 1½" minimum bore
 10. Mount closers on non-public side of door, unless otherwise noted in specification
 11. Closers shall be non-handed, non-sized and multi-sized.
- G. Door Stops: Provide a dome floor or wall stop for every opening as listed in the hardware sets.
1. Wall stop and floor stop shall be wrought bronze, brass or stainless steel.
 2. Provide fastener suitable for wall construction.
 3. Coordinate reinforcement of walls where wall stop is specified.
 4. Provide dome stops where wall stops are not practical. Provide spacers or carpet riser for floor conditions encountered
- H. Over Head Stops: Provide a Surface mounted or concealed overhead when a floor or wall stop cannot be used or when listed in the hardware set.
1. Concealed overhead stops shall be heavy duty bronze or stainless steel.
 2. Surface overhead stops shall be heavy duty bronze or stainless steel.
- I. Kickplates: Provide with four beveled edges ANSI J102, 10 inches high by width less 2 inches on single doors and 1 inch on pairs of doors. Furnish oval-head countersunk screws to match finish.
- J. Mop plates: Provide with four beveled edges ANSI J103, 4 inches high by width less 1 inch on single doors and 1 inch on pairs of doors. Furnish oval-head countersunk screws to match finish.
- K. Seals: All seals shall be finished to match adjacent frame color. Seals shall be furnished as listed in schedule. Material shall be UL listed for labeled openings.
- L. Weatherstripping: Provide at head and jambs only those units where resilient or flexible seal strip is easily replaceable. Where bar-type weatherstrip is used with parallel arm mounted closers install weatherstrip first.
1. Weatherstrip shall be resilient seal of (Neoprene, Polyurethane, Vinyl, Pile, Nylon Brush, Silicone)
 2. UL10C Positive Pressure rated seal set when required.
- M. Door Bottoms/Sweeps: Surface mounted or concealed door bottom where listed in the hardware sets.
1. Door seal shall be resilient seal of (Neoprene, Polyurethane, Nylon Brush, Silicone)
 2. UL10C Positive Pressure rated seal set when required.
- N. Thresholds: Thresholds shall be aluminum beveled type with maximum height of ½" for conformance with ADA requirements. Furnish as specified and per details. Provide fasteners and screws suitable for floor conditions.

- O. Provide one wall mounted Telkee, Lund or MMF series key cabinet complete with hooks, index and tags to accommodate 50% expansion. Coordinate mounting location with architect.
- P. Silencers: Furnish silencers on all interior frames, 3 for single doors, 2 for pairs. Omit where any type of seals occur.

2.3 FINISH:

- A. Designations used in Schedule of Finish Hardware - 3.05, and elsewhere to indicate hardware finishes are those listed in ANSI/BHMA A156.18 including coordination with traditional U.S. finishes shown by certain manufacturers for their products
- B. Powder coat door closers to match other hardware, unless otherwise noted.
- C. Aluminum items shall be finished to match predominant adjacent material. Seals to coordinate with frame color.

2.4 KEYS AND KEYING:

- A. Cylinders, removable and interchangeable core system: Dorma 6-pin. As directed by owner.
- B. Transmit Grand Masterkeys, Masterkeys and other Security keys to Owner by Registered Mail, return receipt requested.
- C. Furnish keys in the following quantities:
 - 1. 1 each Grand Masterkeys
 - 2. 4 each Masterkeys
 - 3. 2 each Change keys each keyed core
 - 4. 15 each Construction masterkeys
 - 5. 1 each Control keys
- D. Keying Schedule: Arrange for a keying meeting, and programming meeting with Architect Owner and hardware supplier, and other involved parties to ensure locksets and locking hardware, are functionally correct and keying and programming complies with project requirements. Furnish 3 typed copies of keying and programming schedule to Architect.

PART 3 - EXECUTION

3.1 EXAMINATION

- A. Verification of conditions: Examine doors, frames, related items and conditions under which Work is to be performed and identify conditions detrimental to proper and or timely completion.
 - 1. Do not proceed until unsatisfactory conditions have been corrected.

3.2 HARDWARE LOCATIONS:

- A. Mount hardware units at heights indicated in the following publications except as specifically indicated or required to comply with the governing regulations.
 - 1. Recommended Locations for Builder's Hardware for Standard Steel Doors and Frames, by the Door and Hardware Institute (DHI).
 - 2. Recommended locations for Architectural Hardware for flush wood doors (DHI).
 - 3. WDMA Industry Standard I.S.-1A-04, Industry Standard for Architectural wood flush doors.

3.3 INSTALLATION:

- A. Install each hardware item per manufacturer's instructions and recommendations. Do not install surface mounted items until finishes have been completed on the substrate. Set units level, plumb and true to line and location. Adjust and reinforce the attachment substrate as necessary for proper installation and operation.
- B. Conform to local governing agency security ordinance.
- C. Install Conforming to ICC/ANSI A117.1 Accessible and Usable Building and Facilities.
 - 1. Adjust door closer sweep periods so that from open position of 70 degrees, door will take at least 3 seconds to move to a point 3 inches from latch, measured to landing side of door.
- D. Installed hardware using the manufacturers fasteners provided. Drill and tap all screw holes located in metallic materials. Do not use "Riv-Nuts" or similar products.

3.4 FIELD QUALITY CONTROL AND FINAL ADJUSTMENT

- A. Contractor/Installers, Field Services: After installation is complete, contractor shall inspect the completed door openings on site to verify installation of hardware is complete and properly adjusted, in accordance with both the Contract Documents and final shop drawings.
 - 1. Check and adjust closers to ensure proper operation.
 - 2. Check latchset, lockset, and exit devices are properly installed and adjusted to ensure proper operation.
 - a. Verify levers are free from binding.
 - b. Ensure latchbolts and dead bolts are engaged into strike and hardware is functioning.
 - 3. Report findings, in writing, to architect indicating that all hardware is installed and functioning properly. Include recommendations outlining corrective actions for improperly functioning hardware if required.

3.5 DEMONSTRATION

- A. Instruct Owner's personnel in operation and maintenance of hardware units.

3.6 SCHEDULE OF FINISH HARDWARE:

SET #01

1	Continuous Hinge	661HD UL	AL	ST
1	Exit Device	9300 x YC08C T	630	DM
1	Permanent Core	76	626	DM
1	Closer	8616 S-ISJ FC	689	DM
1	Seal	By storefront manufacturer		
1	Door Bottom	2251 AV		PE
1	Threshold	271A or as detailed		PE

SET #02

3	Hinges	FBB179 4 1/2 X 4 1/2	652	ST
1	Passage Set	CL710 LCE	626	DM
1	Kick Plate	90 10" x 2" LDW	630	DJ
1	Wall Bumper	1407	630	DJ
1	Seal	S88 D (head & jambs)		PE

SET #03

3	Hinges	FBB179 4 1/2 X 4 1/2	652	ST
1	Office Lockset	CL753T LCE	626	DM
1	Permanent Core	76	626	DM
1	Wall Bumper	1407	630	DJ
1	Seal (sound dampening)	S88 D (head & jambs)		PE

SET #04

3	Hinges	FBB179 4 1/2 X 4 1/2	652	ST
1	Classroom Lockset	CL770T LCE	626	DM
1	Permanent Core	76	626	DM
1	Wall Bumper	1407	630	DJ
3	Door Silencers	1229A	GR	TR

SET #05

3	Hinges	FBB179 4 1/2 X 4 1/2 NRP	652	ST
1	Exit Device	F9300 x YC03R T	630	DM
1	Permanent Core	76	626	DM
1	Closer	8616 SPA FC	689	DM
1	Kick Plate	90 10" x 2" LDW	630	DJ
1	Wall Bumper	1407	630	DJ
1	Seal	S88 D (head & jambs)		PE

SET #06

3	Hinges	FBB179 4 1/2 X 4 1/2	652	ST
1	Office Lockset	CL753T LCE	626	DM
1	Permanent Core	76	626	DM
1	Closer	8616 AF86 FC	689	DM
1	Kick Plate	90 10" x 2" LDW	630	DJ
1	Wall Bumper	1407	630	DJ
1	Seal	S88 D (head & jambs)		PE

SET #07

3	Hinges	F191 4 1/2 X 4 1/2 NRP	630	ST
1	Storeroom Lockset	CL780T LCE	626	DM
1	Permanent Core	76	626	DM
1	Closer	8616 SPA FC	689	DM
1	Stop	1462	BL	DJ
1	Seal	S88 D (head & jambs)		PE
1	Door Bottom	2251 AV		PE
1	Threshold	271A or as detailed		PE

SET #08

3	Hinges	FBB191 4 1/2 X 4 1/2	630	ST
1	Privacy w/occupancy ind.	M9046 LAA	630	DM
1	Kick Plate	90 10" x 2" LDW	630	DJ
1	Mop Plate	90 6" x 35"	630	DJ
1	Seal (sound dampening)	S88 D (head & jambs)		PE
1	Robe Hook	302	626	DJ

SET #09

3	Hinges	FBB191 4 1/2 X 4 1/2	630	ST
1	Storeroom Lockset	CL780T LCE	626	DM
1	Permanent Core	76	626	DM
1	Closer	8616 AF86 FC	689	DM
1	Kick Plate	90 10" x 2" LDW	630	DJ
1	Wall Bumper	1407	630	DJ
1	Seal	S88 D (head & jambs)		PE
1	Door Bottom	234 AV		PE
1	Threshold	151 A		PE

SET #10

3	Hinges	FBB191 4 1/2 X 4 1/2	630	ST
1	Push Plate	71 4" X 16"	630	DJ
1	Pull Plate	7130	630	DJ
1	Closer	8616 AF86 FC	689	DM
1	Kick Plate	90 10" x 2" LDW	630	DJ
1	Mop Plate	90 6" x 35"	630	DJ
1	Wall Bumper	1407	630	DJ
1	Seal	S88 D (head & jambs)		PE

SET #11

3	Hinges	FBB179 4 1/2 X 4 1/2	652	ST
1	Storeroom Lockset	CL780T LCE	626	DM
1	Permanent Core	76	626	DM
1	Closer	8616 AF86 FC	689	DM
1	Kick Plate	90 10" x 2" LDW	630	DJ
1	Wall Bumper	1407	630	DJ
1	Seal	S88 D (head & jambs)		PE
1	Door Bottom	234 AV		PE
1	Threshold	151 A		PE

SET #12

3	Hinges	FBB168 4 1/2 X 4 1/2 NRP	652	ST
1	Exit Device	9300 x YC03R CD T	630	DM
2	Permanent Core	76	626	DM
1	Closer	8616 SPA FC	689	DM
1	Kick Plate	90 10" x 2" LDW	630	DJ
1	Wall Bumper	1407	630	DJ
1	Seal	S88 D (head & jambs)		PE

SET #13

3	Hinges	FBB199 4 1/2 X 4 1/2 NRP	630	ST
1	Exit Device	9300 x YC03R CD T	630	DM
2	Permanent Core	76	626	DM
1	Closer	8616 SPA FC	689	DM
1	Kick Plate	90 10" x 2" LDW	630	DJ
1	Stop	1462	BL	DJ
1	Seal	S88 D (head & jambs)		PE
1	Door Bottom	2251 AV		PE
1	Threshold	271A or as detailed		PE

SET #14

3	Hinges	FBB179 4 1/2 X 4 1/2	652	ST
1	Classroom Lockset	CL770T LCE	626	DM
1	Permanent Core	76	626	DM
1	Closer	8616 S-IS FC	689	DM
1	Kick Plate	90 10" x 2" LDW	630	DJ
3	Door Silencers	1229A	GR	TR

SET #15

3	Hinges	FBB179 4 1/2 X 4 1/2	652	ST
1	Storeroom Lockset	CL780T LCE	626	DM
1	Permanent Core	76	626	DM
1	Overhead Stop	700 Series	689	DM
3	Door Silencers	1229A	GR	TR

SET #16

3	Hinges	FBB179 4 1/2 X 4 1/2 NRP	652	ST
1	Classroom Lockset	CL770T LCE	626	DM
1	Permanent Core	76	626	DM
1	Closer	8616 AF86 FC	689	DM
1	Kick Plate	90 10" x 2" LDW	630	DJ
1	Seal	S88 D (head & jambs)		PE
1	Door Bottom	234 AV		PE

SET #17

3	Hinges	FBB168 4 1/2 X 4 1/2 NRP	652	ST
1	Classroom Lockset	CL770T LCE	626	DM
1	Permanent Core	76	626	DM
1	Closer	8616 SPA FC	689	DM
1	Kick Plate	90 10" x 2" LDW	630	DJ
1	Wall Bumper	1407	630	DJ
1	Seal	S88 D (head & jambs)		PE

SET #18

3	Hinges	FBB199 4 1/2 X 4 1/2 NRP	630	ST
1	Classroom Lockset	CL770T LCE	626	DM
1	Permanent Core	76	626	DM
1	Closer	8616 SPA FC	689	DM
1	Kick Plate	90 10" x 2" LDW	630	DJ
1	Stop	1462	BL	DJ
1	Seal	S88 D (head & jambs)		PE
1	Door Bottom	2251 AV		PE
1	Threshold	271A or as detailed		PE

SET #19

All Hardware By wall system manufacturer BY

SET #20

3	Hinges	FBB191 4 1/2 X 4 1/2	630	ST
1	Passage Set	CL710 LCE	626	DM
1	Kick Plate	90 10" x 2" LDW	630	DJ
1	Mop Plate	90 6" x 35"	630	DJ
1	Wall Bumper	1407	630	DJ
3	Door Silencers	1229A	GR	TR

SET #21

3	Hinges	FBB179 4 1/2 X 4 1/2	652	ST
1	Passage Set	CL710 LCE	626	DM
1	Wall Bumper	1407	630	DJ
3	Door Silencers	1229A	GR	TR

SET #22

All Hardware By Elev door manufacturer

SET #23

3	Hinges	FBB179 4 1/2 X 4 1/2	652	ST
1	Exit Device	F9300 x YC23	630	DM
1	Closer	8616 AF86 FC	689	DM
1	Wall Bumper	1407	630	DJ
1	Seal	S88 D (head & jambs)		PE

SET #24

3	Hinges	FBB191 4 1/2 X 4 1/2 NRP	630	ST
1	Exit Device	F9300 x YC03R T	630	DM
1	Permanent Core	76	626	DM
1	Closer	8616 SPA FC	689	DM
1	Kick Plate	90 10" x 2" LDW	630	DJ
1	Stop	1462	BL	DJ
1	Seal	S88 D (head & jambs)		PE
1	Door Bottom	2251 AV		PE
1	Threshold	271A or as detailed		PE

SET #25 Not used

SET #26

3	Hinges	FBB179 4 1/2 X 4 1/2	652	ST
1	Storeroom Lockset	CL780T LCE	626	DM
1	Permanent Core	76	626	DM
1	Wall Bumper	1407	630	DJ
3	Door Silencers	1229A	GR	TR

SET #27

3	Hinges	FBB168 4 1/2 X 4 1/2 NRP	652	ST
1	Classroom Lockset	CL770T LCE	626	DM
1	Permanent Core	76	626	DM
1	Closer	8616 AF86 FC	689	DM
1	Kick Plate	90 10" x 2" LDW	630	DJ
1	Wall Bumper	1407	630	DJ
1	Seal	S88 D (head & jambs)		PE
1	Door Bottom	234 AV		PE
1	Threshold	151 A		PE

SET #28

3	Hinges	FBB191 4 1/2 X 4 1/2 NRP	630	ST
1	Storeroom Lockset	CL780T LCE	626	DM
1	Permanent Core	76	626	DM
1	Closer	8616 S-DS FC	689	DM
1	Seal	S88 D (head & jambs)		PE
1	Door Bottom	2251 AV		PE
1	Threshold	271A or as detailed		PE

SET #29

6	Hinges	FBB191 4 1/2 X 4 1/2 NRP	630	ST
2	Flush Bolt	1555	626	DJ
1	Dust Proof Strike	1570	626	DJ
1	Storeroom Lockset	CL780T LCE	626	DM
1	Permanent Core	76	626	DM
1	Closer	8616 S-DS FC	689	DM
1	Seal	S88 D (head & jambs)		PE
2	Door Bottom	2251 AV		PE
1	Threshold	271A or as detailed		PE

SET #30

3	Hinges	FBB179 4 1/2 X 4 1/2	652	ST
1	Classroom Lockset	CL770T LCE	626	DM
1	Closer	8616 AF86 FC	689	DM
1	Wall Bumper	1407	630	DJ
1	Seal	S88 D (head & jambs)		PE
1	Door Bottom	2251 AV		PE
1	Threshold	271A or as detailed		PE

UNITS

SET #U-01 - Unit Entry

1	Hinges	FBB179 4 1/2 X 4 1/2	652	ST
2	Spring Hinges	2060R 4 1/2 X 4 1/2	652	ST
1	Smart Deadbolt	BE467F ADDISON TRIM	619	SC
1	Passage Set	W101S Q	626	FL
1	Kick Plate	90 10" x 2" LDW	630	DJ
1	Wall Bumper	1407	630	DJ
1	Door Viewer	ULDV-180	626	DJ
1	Seal	S88 D (head & jambs)		PE
1	Door Bottom	234 AV		PE
1	Threshold	151 A		PE

SET #U-02 - Exterior Entry

1	Hinges	FBB179 4 1/2 X 4 1/2	652	ST
2	Spring Hinges	2060R 4 1/2 X 4 1/2	652	ST
1	Smart Deadbolt	BE467F ADDISON TRIM	619	SC
1	Passage Set	W101S Q	626	FL
1	Kick Plate	90 10" x 2" LDW	630	DJ
1	Wall Bumper	1407	630	DJ
1	Seal	S88 D (head & jambs)		PE
1	Door Bottom	2251 AV		PE
1	Threshold	271A or as detailed		PE

SET #U-03 - Bed/bath

3	Hinges	F179 3 1/2 X 3 1/2 1/4" Radius Corners	652	ST
1	Privacy Set	W301S Q	626	FL
1	Wall Bumper	1407	630	DJ
1	Robe Hook	302	626	DJ

SET #U-04 – Closet

3	Hinges	F179 3 1/2 X 3 1/2 1/4" Radius Corners	652	ST
1	Passage Set	W101S Q	626	FL
1	Wall Bumper	1407	630	DJ

SET #U-05 – Patio

3	Hinges	F191 4 1/2 X 4 1/2 NRP	630	ST
1	Deadlock	D241P	626	FL
1	Passage Set	W101S Q	626	FL
1	Universal Dome Stop	1447	626	DJ
1	Seal	S88 D (head & jambs)		PE
1	Door Bottom	2251 AV		PE
1	Threshold	271A or as detailed		PE

SET #U-06 - Closet Pair

6	Hinges	F179 3 1/2 X 3 1/2 1/4" Radius Corners	652	ST
2	Roller Latch	1702	626	DJ
2	Dummy Trim	W12 Q	626	FL
2	Hinge Stop	1502	626	DJ

SET #U-07 - Bi-Pass

1	Set Sliding Door Hardware	BP60-00-72		ST
2	Flush Cup Pull	1848	630	DJ

END OF SECTION 087100

SECTION 088000

GLAZING

PART 1 - GENERAL

1.1 SUMMARY

A. Section Includes:

1. Glass for:
 - a. Windows.
 - b. Doors.
 - c. Interior borrowed lites.
 - d. Storefront framing.
 - e. Exterior canopies.
2. Glazing sealants and accessories.

B. Coordination:

1. Coordinate glazing channel dimensions to provide necessary bite on glass, minimum edge and face clearances, and adequate sealant thicknesses, with reasonable tolerances.

C. Preinstallation Meetings: Conduct conference at Project site

1. Review and finalize construction schedule and verify availability of materials, Installer's personnel, equipment, and facilities needed to make progress and avoid delays.
2. Review temporary protection requirements for glazing during and after installation.

1.2 ACTION SUBMITTALS

A. Product Data: For each type of product.

B. Sustainable Design Submittals:

1. Product Data: For sealants, indicating VOC content.
2. Laboratory Test Reports: For sealants, indicating compliance with requirements for low-emitting materials.

C. Glass Samples: For each type of glass product other than clear monolithic vision glass.

1. Size: Not less than 8 inch square.

D. Glazing Accessory Samples: For gaskets and colored spacers, in 12 inch lengths.

E. Glazing Schedule: List glass types and thicknesses for each size opening and location. Use same designations indicated on Drawings.

F. Delegated-Design Submittal: For glass indicated to comply with performance requirements and design criteria, including analysis data signed and sealed by the qualified professional engineer responsible for their preparation.

1.3 INFORMATIONAL SUBMITTALS

A. Qualification Data: For Installer and manufacturers of fabricated glass units.

B. Product Certificates: For glass.

C. Product Test Reports: For coated glass and insulating glass, for tests performed by a qualified testing agency.

1. For glazing sealants, provide test reports based on testing current sealant formulations within previous 36 month period.

- D. Preconstruction adhesion and compatibility test report.
- E. Sample Warranties: For special warranties.

1.4 QUALITY ASSURANCE

- A. Manufacturer Qualifications for Insulating-Glass Units with Sputter-Coated, Low-E Coatings: Qualified insulating-glass manufacturer who is approved and certified by coated-glass manufacturer.
- B. Installer Qualifications: Qualified installer who employs glass installers for this Project who are certified under National Glass Association's Certified Glass Installer Program.
- C. Glass Testing Agency Qualifications: Qualified independent testing agency accredited according to the NFRC CAP 1 Certification Agency Program.
- D. Mockups: Build mockups to verify selections made under Sample submittals and to demonstrate aesthetic effects and set quality standards for materials and execution.
 - 1. Install glazing in mockups specified in Section 084113 – Aluminum-Framed Entrances and Storefronts to match glazing systems required for Project, including glazing methods.
 - 2. Subject to compliance with requirements, approved mockups may become part of completed Work if undisturbed at time of Substantial Completion.

1.5 DELIVERY, STORAGE, AND HANDLING

- A. Protect glazing materials according to manufacturer's written instructions. Prevent damage to glass and glazing materials from condensation, temperature changes, direct exposure to sun, or other causes.
- B. Comply with insulating-glass manufacturer's written instructions for venting and sealing units to avoid hermetic seal ruptures due to altitude change.

1.6 FIELD CONDITIONS

- A. Environmental Limitations: Do not proceed with glazing when ambient and substrate temperature conditions are outside limits permitted by glazing material manufacturers and when glazing channel substrates are wet from rain, frost, condensation, or other causes.

1.7 WARRANTY

- A. Manufacturer's Special Warranty for Coated-Glass Products: Manufacturer agrees to replace coated-glass units that deteriorate within specified warranty period. Deterioration of coated glass is defined as defects developed from normal use that are not attributed to glass breakage or to maintaining and cleaning coated glass contrary to manufacturer's written instructions. Defects include peeling, cracking, and other indications of deterioration in coating.
 - 1. Warranty Period: 10 years from date of Substantial Completion.
- B. Manufacturer's Special Warranty for Laminated Glass: Manufacturer agrees to replace laminated-glass units that deteriorate within specified warranty period. Deterioration of laminated glass is defined as defects developed from normal use that are not attributed to glass breakage or to maintaining and cleaning laminated glass contrary to manufacturer's written instructions. Defects include edge separation, delamination materially obstructing vision through glass, and blemishes exceeding those allowed by referenced laminated-glass standard.
 - 1. Warranty Period: 5 years from date of Substantial Completion.

- C. Manufacturer's Special Warranty for Insulating Glass: Manufacturer agrees to replace insulating-glass units that deteriorate within specified warranty period. Deterioration of insulating glass is defined as failure of hermetic seal under normal use that is not attributed to glass breakage or to maintaining and cleaning insulating glass contrary to manufacturer's written instructions. Evidence of failure is the obstruction of vision by dust, moisture, or film on interior surfaces of glass.
 - 1. Warranty Period: 10 years from date of Substantial Completion.

PART 2 - PRODUCTS

2.1 MANUFACTURERS

- A. Source Limitations for Glass: Obtain from single source from single manufacturer for each glass type.
- B. Source Limitations for Glazing Accessories: Obtain from single source from single manufacturer for each product and installation method.

2.2 PERFORMANCE CRITERIA

- A. General: Installed glazing systems shall withstand normal thermal movement and wind and impact loads (where applicable) without failure, including loss or glass breakage attributable to defective manufacture, fabrication, or installation; failure of sealants or gaskets to remain watertight and airtight; deterioration of glazing materials; or other defects in construction.
- B. Delegated Design: Engage a qualified professional engineer, as defined in Section 014000 – Quality Requirements, to design glazing.
- C. Structural Performance: Glazing shall withstand the following design loads within limits and under conditions indicated determined according to the IBC and ASTM E1300.
 - 1. Design Wind Pressures: As indicated on Drawings.
 - 2. Design Snow Loads: As indicated on Drawings.
 - 3. Maximum Lateral Deflection: For glass supported on all 4 edges, limit center-of-glass deflection at design wind pressure to not more than 1/50 times short-side length or 1 inch, whichever is less.
- D. Safety Glazing: Where safety glazing is indicated, provide glazing that complies with 16 CFR 1201, Category II.
 - 1. Provide Kind HS (heat-strengthened) float glass in place of annealed glass where needed to resist thermal stresses induced by differential shading of individual glass lites and to comply with glass design requirements specified in "Performance Criteria" and "Quality Assurance" Articles.
 - 2. Provide Kind FT (fully tempered) glass lites where safety glass is indicated or required by AHJ.
- E. Thermal Performance Properties: Provide glass with performance properties specified, as indicated in manufacturer's published test data, based on procedures indicated below:
 - 1. For monolithic-glass lites, properties are based on units with lites 6 mm thick.
 - 2. For laminated-glass lites, properties are based on products of construction indicated.
 - 3. For insulating-glass units, properties are based on units of thickness indicated for overall unit and for each lite.
 - 4. U-Factors: Center-of-glazing values, according to NFRC 100 and based on LBL's WINDOW 5.2 computer program, expressed as Btu/sq. ft. x h x deg F.
 - 5. Solar Heat-Gain Coefficient and Visible Transmittance: Center-of-glazing values, according to NFRC 200 and based on LBL's WINDOW 5.2 computer program.
 - 6. Visible Reflectance: Center-of-glazing values, according to NFRC 300.

2.3 GLASS PRODUCTS, GENERAL

- A. Glazing Publications: Comply with published recommendations of glass product manufacturers and organizations below unless more stringent requirements are indicated. Refer to these publications for glazing terms not otherwise defined in this Section or in referenced standards.
 - 1. NGA Publications: "Laminated Glazing Reference Manual" and "Glazing Manual."
 - 2. IGMA Publication for Insulating Glass: SIGMA TM-3000, "North American Glazing Guidelines for Sealed Insulating Glass Units for Commercial and Residential Use."
- B. Safety Glazing Labeling: Where safety glazing is indicated, permanently mark glazing with certification label of SGCC or another certification agency acceptable to authorities having jurisdiction. Label shall indicate manufacturer's name, type of glass, thickness, and safety glazing standard with which glass complies.
- C. Insulating-Glass Certification Program: Permanently marked either on spacers or on at least 1 component lite of units with appropriate certification label of IGCC.
- D. Thickness: Where glass thickness is indicated, it is a minimum. Provide glass that complies with performance requirements and is not less than the thickness indicated.
 - 1. Minimum Glass Thickness for Exterior Lites: 6 mm.
- E. Strength: Provide the following glass types to comply with Performance Criteria Article.
 - 1. Where annealed float glass is indicated, provide annealed float glass, heat-strengthened float glass (Kind HS), or fully tempered float glass (Kind FT).
 - 2. Where heat-strengthened float glass is indicated, provide heat-strengthened float glass (Kind HS) or fully tempered float glass (Kind FT).
 - 3. Where fully tempered float glass is indicated or required by applicable code, provide fully tempered float glass (Kind FT).

2.4 GLASS PRODUCTS

- A. Clear, Annealed Float Glass: ASTM C1036, Type I, Class I (clear), Quality-Q3.
- B. Fully Tempered Float Glass: ASTM C1048, Kind FT (fully tempered), Condition A (uncoated) unless otherwise indicated, Type I, Class 1 (clear) or Class 2 (tinted) as indicated, Quality-Q3.
 - 1. Fabrication Process: By horizontal (roller-hearth) process with roll-wave distortion parallel to bottom edge of glass as installed unless otherwise indicated.
- C. Heat-Strengthened Float Glass: ASTM C1048, Kind HS (heat strengthened), Type I, Condition A (uncoated) unless otherwise indicated, Type I, Class 1 (clear) **[or Class 2 (tinted) as indicated]**, Quality-Q3.
 - 1. Fabrication Process: By horizontal (roller-hearth) process with roll-wave distortion parallel to bottom edge of glass as installed unless otherwise indicated.

2.5 LAMINATED GLASS

- A. Laminated Glass: ASTM C 1172. Use materials that have a proven record of no tendency to bubble, discolor, or lose physical and mechanical properties after fabrication and installation.
 - 1. Construction: Laminate glass with polyvinyl butyral interlayer or ionomeric polymer interlayer to comply with interlayer manufacturer's written instructions.
 - 2. Interlayer Thickness: Provide thickness as needed to comply with requirements.
 - 3. Interlayer Color:
 - a. Clear: Unit balcony railing balustrades
 - b. Translucent: Areas adjacent to equipment or where screening non-occupied areas from view

2.6 INSULATING GLASS

- A. Insulating-Glass Units: Factory-assembled units consisting of sealed lites of glass separated by a dehydrated interspace, qualified according to ASTM E2190.
1. Sealing System: Dual seal, with manufacturer's standard polyisobutylene primary and silicone secondary, polysulfide and silicone, or as recommended by manufacturer for application.
 2. Warm-Edge Perimeter Spacer: Spacer manufacturer's system consisting of polypropylene-covered stainless steel, nonmetallic laminate or tube, silicone, with integral desiccant and vapor barrier.
 - a. Products: Subject to compliance with requirements, provide one of the following:
 - 1) JE Berkowitz, LP: Winduo Insulating Glass
 - 2) Quanex Building Products: Super Spacer TriSeal
 - 3) Technoform North America.: TGI-Spacer.
 - 4) Thermix; a brand of Ensinger USA; Thermix Spacers.
 - 5) Viracon Inc.: Viracon Thermal Spacer (VTS).
 - 6) Vitro Architectural Glass: Intercept Spacer System.
 - 7) Approved substitution.
 - b. Spacer Width: 1/2 inch or as required for specified insulating glass unit.
 - c. Spacer Height: 0.27 inch.
 - d. Corner Construction: Manufacturer's standard corner construction.
 - e. Color: Black or as selected by Architect.
 3. Desiccant: Molecular sieve, silica gel, or a blend of both.

2.7 GLAZING SEALANTS

- A. General:
1. Compatibility: Compatible with one another and with other materials they contact, including glass products, seals of insulating-glass units, and glazing channel substrates, under conditions of service and application, as demonstrated by sealant manufacturer based on testing and field experience.
 2. Suitability: Comply with sealant and glass manufacturers' written instructions for selecting glazing sealants suitable for applications indicated and for conditions existing at time of installation.
 3. Verify sealants have a VOC content of 250 g/L or less.
 4. Verify sealants comply with testing and product requirements of California Department of Public Health's "Standard Method for the Testing and Evaluation of Volatile Organic Chemical Emissions from Indoor Sources Using Environmental Chambers."
 5. Colors of Exposed Glazing Sealants: As selected by Architect from manufacturer's full range.

2.8 GLAZING GASKETS

- A. Dense Compression Gaskets: Molded or extruded gaskets of profile and hardness required to maintain watertight seal, made from EPDM or other silicone-compatible material complying with ASTM C864.
- B. Soft Compression Gaskets: Manufacturer's extruded or molded, closed-cell, integral-skinned EPDM or silicone gaskets complying with ASTM C509, Type II, black; of profile and hardness required to maintain watertight seal.
1. Application: Use where soft compression gaskets will be compressed by inserting dense compression gaskets on opposite side of glazing or pressure applied by means of pressure-glazing stops on opposite side of glazing.

2.9 GLAZING TAPES

- A. Back-Bedding Mastic Glazing Tapes: Preformed, butyl-based, 100 percent solids elastomeric tape; nonstaining and nonmigrating in contact with nonporous surfaces; with or without spacer rod as recommended in writing by tape and glass manufacturers for application indicated; and complying with ASTM C1281 and AAMA 800 for products indicated below:
 - 1. Products: Subject to compliance with requirements, provide one of the following:
 - a. CR Laurence: GT Series Butyl Tapes.
 - b. GSSI Sealants: MB-10A or EZ TRIM Sealant Tape.
 - c. ITW Polymers Sealants: Tacky Tape SM5 Series.
 - d. Pecora Corp.: Extru-Seal.
 - e. Tremco: Tremco 440 Tape.
 - f. Approved substitution.
 - 2. Shore Hardness: ASTM 2240; Type A durometer hardness of 15 to 20.
 - 3. AAMA 806.3 tape, for glazing applications in which tape is subject to continuous pressure.
- B. Polyethylene Foam Glazing Tapes: Cross-linked, closed-cell polyethylene foam tape; factory coated with rubber adhesive on both surfaces; and complying with AAMA 800 for the following types:
 - 1. Products: Subject to compliance with requirements, provide one of the following:
 - a. Pres-On: P4200 Series.
 - b. Approved substitution.
 - 2. Shore Hardness: ASTM 2240; Type A durometer hardness of 15 to 20.
 - 3. AAMA 810.1, Type 1, for glazing applications in which tape acts as primary sealant.

2.10 MISCELLANEOUS GLAZING MATERIALS

- A. General: Provide products of material, size, and shape complying with referenced glazing standard, with requirements of manufacturers of glass and other glazing materials for application indicated, and with a proven record of compatibility with surfaces contacted in installation.
- B. Cleaners, Primers, and Sealers: Types recommended by sealant or gasket manufacturer.
- C. Setting Blocks:
 - 1. EPDM or other silicone-compatible material.
 - 2. Shore Hardness: ASTM 2240; Type A durometer hardness of 85, plus or minus 5.
 - 3. Type recommended by glass manufacturer.
- D. Spacers:
 - 1. Blocks or continuous extrusions of EPDM or other silicone-compatible material.
 - 2. Shore Hardness: ASTM 2240; as required by glass manufacturer to maintain glass lites in place for installation indicated.
 - 3. Type recommended by glass manufacturer.
- E. Edge Blocks:
 - 1. EPDM or other silicone-compatible material.
 - 2. Shore Hardness: ASTM 2240; as required by glass manufacturer to maintain glass lites in place for installation indicated.
 - 3. Type recommended by glass manufacturer.

2.11 FABRICATION OF GLAZING UNITS

- A. Fabricate glazing units in sizes required to fit openings indicated for Project, with edge and face clearances, edge and surface conditions, and bite complying with written instructions of product manufacturer and referenced glazing publications, to comply with system performance requirements.
 - 1. Allow for thermal movements from ambient and surface temperature changes acting on glass framing members and glazing components.
 - a. Temperature Change: 120 deg F, ambient; 180 deg F, material surfaces.

PART 3 - EXECUTION

3.1 EXAMINATION

- A. Examine framing, glazing channels, and stops, with Installer present, for compliance with the following:
 - 1. Manufacturing and installation tolerances, including those for size, squareness, and offsets at corners.
 - 2. Presence and functioning of weep systems.
 - 3. Minimum required face and edge clearances.
 - 4. Effective sealing between joints of glass-framing members.
- B. Proceed with installation only after unsatisfactory conditions have been corrected.

3.2 PREPARATION

- A. Clean glazing channels and other framing members receiving glass immediately before glazing. Remove coatings not firmly bonded to substrates.
- B. Examine glazing units to locate exterior and interior surfaces. Label or mark units as needed so that exterior and interior surfaces are readily identifiable. Do not use materials that leave visible marks in the completed Work.

3.3 GLAZING, GENERAL

- A. Comply with combined written instructions of manufacturers of glass, sealants, gaskets, and other glazing materials, unless more stringent requirements are indicated, including those in referenced glazing publications.
- B. Protect glass edges from damage during handling and installation. Remove damaged glass from Project site and legally dispose of off Project site. Damaged glass includes glass with edge damage or other imperfections that, when installed, could weaken glass, impair performance, or impair appearance.
- C. **[Apply primers to joint surfaces where required for adhesion of sealants, as determined by preconstruction testing.]**
- D.]Install setting blocks in sill rabbets, sized and located to comply with referenced glazing publications, unless otherwise required by glass manufacturer. Set blocks in thin course of compatible sealant suitable for heel bead.
- E. Do not exceed edge pressures stipulated by glass manufacturers for installing glass lites.
- F. Provide spacers for glass lites where length plus width is larger than 50 inches.
 - 1. Locate spacers directly opposite each other on both inside and outside faces of glass. Install correct size and spacing to preserve required face clearances, unless gaskets and glazing tapes are used that have demonstrated ability to maintain required face clearances and to comply with system performance requirements.
 - 2. Provide 1/8 inch minimum bite of spacers on glass and use thickness equal to sealant width. With glazing tape, use thickness slightly less than final compressed thickness of tape.
- G. Provide edge blocking where indicated or needed to prevent glass lites from moving sideways in glazing channel, as recommended in writing by glass manufacturer and according to requirements in referenced glazing publications.
- H. Set glass lites in each series with uniform pattern, draw, bow, and similar characteristics.
- I. Set glass lites with proper orientation so that coatings face exterior or interior as specified.

- J. Where wedge-shaped gaskets are driven into one side of channel to pressurize sealant or gasket on opposite side, provide adequate anchorage so gasket cannot walk out when installation is subjected to movement.
- K. Square cut wedge-shaped gaskets at corners and install gaskets in a manner recommended by gasket manufacturer to prevent corners from pulling away; seal corner joints and butt joints with sealant recommended by gasket manufacturer.

3.4 TAPE GLAZING

- A. Position tapes on fixed stops so that, when compressed by glass, their exposed edges are flush with or protrude slightly above sightline of stops.
- B. Install tapes continuously, but not necessarily in one continuous length. Do not stretch tapes to make them fit opening.
- C. Cover vertical framing joints by applying tapes to heads and sills first, then to jambs. Cover horizontal framing joints by applying tapes to jambs, then to heads and sills.
- D. Place joints in tapes at corners of opening with adjoining lengths butted together, not lapped. Seal joints in tapes with compatible sealant approved by tape manufacturer.
- E. Do not remove release paper from tape until right before each glazing unit is installed.
- F. Center glass lites in openings on setting blocks, and press firmly against tape by inserting dense compression gaskets formed and installed to lock in place against faces of removable stops. Start gasket applications at corners and work toward centers of openings.

3.5 GASKET GLAZING (DRY)

- A. Cut compression gaskets to lengths recommended by gasket manufacturer to fit openings exactly, with allowance for stretch during installation.
- B. Insert soft compression gasket between glass and frame or fixed stop so it is securely in place with joints miter cut and bonded together at corners.
- C. Installation with Drive-in Wedge Gaskets: Center glass lites in openings on setting blocks, and press firmly against soft compression gasket by inserting dense compression gaskets formed and installed to lock in place against faces of removable stops. Start gasket applications at corners and work toward centers of openings. Compress gaskets to produce a weathertight seal without developing bending stresses in glass. Seal gasket joints with sealant recommended by gasket manufacturer.
- D. Installation with Pressure-Glazing Stops: Center glass lites in openings on setting blocks, and press firmly against soft compression gasket. Install dense compression gaskets and pressure-glazing stops, applying pressure uniformly to compression gaskets. Compress gaskets to produce a weathertight seal without developing bending stresses in glass. Seal gasket joints with sealant recommended by gasket manufacturer.
- E. Install gaskets so they protrude past face of glazing stops.

3.6 CLEANING AND PROTECTION

- A. Immediately after installation remove nonpermanent labels and clean surfaces.
- B. Protect exterior glass from damage immediately after installation by attaching crossed streamers to framing held away from glass. Do not apply markers to glass surface.

- C. Protect glass from contact with contaminating substances resulting from construction operations. Examine glass surfaces adjacent to or below exterior concrete and other masonry surfaces at frequent intervals during construction, but not less than once a month, for buildup of dirt, scum, alkaline deposits, or stains.
 - 1. If, despite such protection, contaminating substances do come into contact with glass, remove substances immediately as recommended in writing by glass manufacturer. Remove and replace glass that cannot be cleaned without damage to coatings.
- D. Remove and replace glass that is damaged during construction period.
- E. Wash glass on both exposed surfaces not more than 4 days before date scheduled for inspections that establish date of Substantial Completion. Wash glass as recommended in writing by glass manufacturer.

3.7 MONOLITHIC GLASS SCHEDULE

- A. Heat-Treated Float Glass (Base product for all field glazed systems):
 - 1. Quality: Glazing select, float, complying with ASTM C1036, Type I, Class 1, Quality q3.
 - 2. Type: Annealed; fully tempered in conformance with ASTM C1048 at indicated locations and where required by Code.
 - 3. Color: Clear.
 - 4. Thickness: 1/4 inch.

3.8 LAMINATED GLASS SCHEDULE

- A. Laminated Glass at overhead glazed canopies.
 - 1. Glass Thickness:
 - a. Vertical Glass: 1/4-inch-thick clear annealed glass, laminated to 1/8 inch thick clear float glass. Nominal 5/8-inch total thickness.
 - b. Horizontal Glass: 2 layers 1/4-inch-thick clear annealed glass. Nominal 1/2-inch total thickness.
 - 2. Plastic Interlayer: Polyvinyl butyral conforming to ASTM C1172, Kind LHS, Safety Rated, CPSC 16 CFR-1201 Category I. Basis of design: DuPont Butacite Polyvinyl Butyral
 - a. Vertical Glass: Minimum 0.030 thick.
 - b. Horizontal Glass: Minimum 0.060 inch thick.
 - c. Color and Visible Light Transmittance: Soft White, 80% VLT
 - 3. Exposed Edges: metal edges where exposed.
 - 4. Color: Clear
 - a. Surface: Clear polished.
 - b. Thickness: 1/4 inch
 - c. Impact Rating: CPSC 16CFR 1201Category II.
 - d. Cutting: Not field cut-able.

3.9 FIRE-RATED GLASS SCHEDULE

- A. Fire-Rated, Safety Rated Glass at 20-minute rated doors and sidelites (Type GL-3 - non-temperature rise type):
 - 1. Proprietary product made of 1/4" (6 mm) thick fire-rated and impact safety rated glazing material complying with ANSI Z97.1 and CPSC 16CFR1201 (Cat. 1 and II) and positive pressure test standards UL 10C, UBC 7-2 and UBC 7-4.
 - 2. Approved Product: Technical Glass Products, Fireglass20.

- B. Fire-Rated, Glass Ceramic Glazing Material at rated doors exceeding 20 minutes (Type GL-4 - temperature rise type):
1. Proprietary product of clear flat sheets of 5 mm [(3/16 inch)] nominal thickness, weighing 4.7 kg/sq m [(2.5 psf)], and surface applied fire-rated film permanently labeled by testing and inspecting agency, acceptable to authorities having jurisdiction, showing product complies with fire-resistive installation indicated, and as follows:
 - a. Polished on both surfaces, transparent with visible light transmission of 76.9 percent.
 - b. Safety glazing complying with ANSI Z97.1 and CPSC 16 CFR 1201.
 2. Product: Subject to compliance with requirements, provide the following product manufactured by Nippon Electric Glass Company, Ltd. and distributed by Technical Glass Products, Inc., Ivyland, PA.
 - a. FireLite NT, standard grade (temperature rise) at Exit Stairs. Glazing limited to 100 sq in.
 - b. See Door Schedule for required fire ratings.
- C. Fire-Rated Glass in 20-minute and 45-minute rated assemblies
1. Proprietary products of clear flat sheets of glass and accessories installed within "EZ Framing" assemblies tested to meet the fire-rating required.
 - a. 20-minute-rated glazing (EZ Framing Assembly SF/WA 20-01): Basis of Design: SAFTI FIRST SuperLite 1-20 – Specialty tempered low-iron glazing without hose stream test. Thickness must be 1/4", 1/2" is available
 - b. 45-minute-rated glazing (EZ Framing Assembly SF/WA 45-01): Basis of Design: SAFTI FIRST SuperLite II-XL – fire protective glazing with fire resistive qualities with hose-stream test, Ultra-clear low-iron tempered glass by PPG. Thickness 3/4".
 - c. Use single-source manufacturer's flame resistant glazing materials, steel angles and tapes to achieve desired rating
- D. 90-minute and 120-minute Fire-resistance rated glass: For use in tested and approved fire-resistance rated assemblies of the same ratings.
1. Proprietary products of clear flat sheets of glass and accessories installed within frame assemblies tested to meet the fire-rating required.
 - a. Basis of Design: Manufacturer: VETROCTECH/Saint Gobain; Products: Contraflam 90 (1-1/2" thick) and Contraflam 120 (1-9/16" thick)
 - b. Use single-source manufacturer's flame resistant glazing materials, tapes, calcium silicate blocking and steel frames to achieve desired rating

3.10 INSULATING GLASS SCHEDULE

- A. Insulating Glass Units (Type GL-1 vision glass at exterior aluminum storefront and doors):
1. Insulating Glass Units: Comprised of dual sealed (polyisobutylate primary seal and silicone secondary seal), double glazed units with air space, filled with moisture absorbing desiccant, between all panes of glass. Aluminum or stainless steel mitered and spigoted corners.
 2. Low E, inert gas filled Insulating Glass Units: Approved manufacturer: Viracon or approved substitute. Provide by single manufacturer and of same color rendition between glass units for Work of this Contract. Performance Requirements: Tested in 1-inch thick insulating units.
 - a. Glass: Clear (tinted and reflective not accepted).
 - b. Inert Gas Filling: Fill space between glass lites with inert gas (argon) to reduce heat loss.
 - c. Visible Daylight Transmittance: 0.69
 - d. SHGC: 0.24.
 - e. Winter U-Value:
 - 1) Minimum 0.38 for Type GL-1, 2 and 5 (Total assembly CDP Value)
 - 2) Glazing in aluminum entry doors may be 0.84 (Total assembly CPD value)

- f. Outer Light:
 - 1) Quality: Glazing select, float, complying with ASTM C1036.
 - 2) Type: Annealed; Heat-strengthened, complying with ASTM C1048, Kind HS, heat strengthened where required by heat load; Kind FT fully tempered, complying with ASTM C1048 where required by code for safety glazing.
 - 3) Low-E coating: #2 surface vacuum deposited. Pyrolytic (hardcoat) coating not accepted.
 - 4) Color: Clear, (opaque at spandrel glass).
- g. Inner Light:
 - 1) Quality: Glazing select, float.
 - 2) Type: Annealed; Heat-strengthened, complying with ASTM C1048, Kind HS, heat strengthened where required by heat load; tempered, complying with ASTM C1048, Kind FT fully tempered where required by code for safety glazing.
 - 3) Low-E coating: Pyrolytic (hardcoat) on #5 surface where required to achieve total assembly CPD U-value.
 - 4) Color: Clear
- h. Center glass:
 - 1) Quality: Glazing select, float.
 - 2) Type: Annealed; Heat-strengthened, complying with ASTM C1048, Kind HS, heat strengthened where required by heat load; tempered, complying with ASTM C1048, Kind FT fully tempered where required by code for safety glazing.
 - 3) Color: Clear

END OF SECTION 088000

SECTION 088300

MIRRORS

PART 1 - GENERAL

1.1 SUMMARY

- A. Section Includes:
 - 1. Silvered flat glass mirrors as follows:
 - a. Annealed monolithic glass mirrors.

1.2 ACTION SUBMITTALS

- A. Product Data: For each type of product.
 - 1. Mirrors. Include description of materials and process used to produce each type of silvered flat glass mirror specified that indicates sources of glass, glass coating components, edge sealer, and quality-control provisions.
- B. Sustainable Design Submittals:
 - 1. Product Data: For adhesives, indicating VOC content.
 - 2. Laboratory Test Reports: For adhesives, indicating compliance with requirements for low-emitting materials.
- C. Shop Drawings: Include mirror elevations, edge details, mirror hardware, and attachment details.
- D. Samples: For each type of the following:
 - 1. Mirrors: 12 inches square, including edge treatment on two adjoining edges.
 - 2. Mirror Clips: Full size.
 - 3. Mirror Trim: 12 inches long.

1.3 INFORMATIONAL SUBMITTALS

- A. Qualification Data: For Installer.
- B. Product Certificates: For each type of mirror and mirror mastic.
- C. Preconstruction Test Reports: From mirror manufacturer indicating that mirror mastic was tested for compatibility and adhesion with mirror backing and substrates on which mirrors are installed.
- D. Sample Warranty: For special warranty.

1.4 CLOSEOUT SUBMITTALS

- A. Maintenance Data: For mirrors to include in maintenance manuals.

1.5 PRECONSTRUCTION TESTING

- A. Preconstruction Mirror Mastic Compatibility Test: Submit mirror mastic products to mirror manufacturer for testing to determine compatibility of mastic with mirror backing.
 - 1. Testing is not required if data are submitted based on previous testing of mirror mastic products and mirror backing matching those submitted.

1.6 DELIVERY, STORAGE, AND HANDLING

- A. Protect mirrors according to mirror manufacturer's written instructions and as needed to prevent damage to mirrors from moisture, condensation, temperature changes, direct exposure to sun, or other causes.
- B. Comply with mirror manufacturer's written instructions for shipping, storing, and handling mirrors as needed to prevent deterioration of silvering, damage to edges, and abrasion of glass surfaces and applied coatings. Store indoors.

1.7 FIELD CONDITIONS

- A. Environmental Limitations: Do not install mirrors until ambient temperature and humidity conditions are maintained at levels indicated for final occupancy.

1.8 WARRANTY

- A. Special Warranty: Manufacturer agrees to replace mirrors that deteriorate within specified warranty period. Deterioration of mirrors is defined as defects developed from normal use that are not attributed to mirror breakage or to maintaining and cleaning mirrors contrary to manufacturer's written instructions. Defects include discoloration, black spots, and clouding of the silver film.
 - 1. Warranty Period: 5 years from date of Substantial Completion.

PART 2 - PRODUCTS

2.1 MANUFACTURERS

- A. Source Limitations for Mirrors: Obtain mirrors from single source from single manufacturer.
- B. Source Limitations for Mirror Accessories: Obtain mirror glazing accessories from single source.

2.2 SILVERED FLAT GLASS MIRRORS

- A. Mirrors, General: ASTM C1503.
- B. Annealed Monolithic Glass Mirrors: Mirror Select Quality, clear.
 - 1. Nominal Thickness: 6.0 mm.
 - 2. Tint Color: None.

2.3 MISCELLANEOUS MATERIALS

- A. Medium-Density Fiberboard (MDF): ANSI A208.2, Grade 130 panels made from softwood fibers, synthetic resins, and fire-retardant chemicals mixed together at time of panel manufacture.
 - 1. Products: Subject to compliance with requirements, provide one of the following:
 - a. ampine; Div. of Timber Products Company: Apex FR.
 - b. ARAUCO North America: Trupan Fire-Rated MDF.
 - c. Roseburg Forest Products Co.: Medite FR.
 - d. Approved substitution.
 - 2. Thickness: 0.50 inch.
 - 3. Surface-Burning Characteristics: Comply with ASTM E84:
 - a. Flame Spread: 25 or less.
 - b. Smoke Developed: 200 or less.
- B. Setting Blocks: Elastomeric material with Shore, Type A durometer hardness of 85, plus or minus 5.
- C. Edge Sealer: Coating compatible with glass coating and approved by mirror manufacturer for use in protecting against silver deterioration at mirrored glass edges.

- D. Mirror Mastic: Adhesive setting compound, asbestos-free, produced specifically for setting mirrors and certified by both mirror and mastic manufacturer as compatible with glass coating and substrates on which mirrors will be installed.
 - 1. Manufacturers: Subject to compliance with requirements, provide products by one of the following:
 - a. Henkel Corp.: Loctite PL 520 Mirror Construction Adhesive.
 - b. Liquid Nails Adhesive; division of Akzo Nobel Paints LLC: LN-930 Mirror Adhesive.
 - c. Palmer Products Corporation: QwikSet Mirro-Mastic.
 - d. Royal Adhesives & Sealants: Gunther Ultra/Bond Mirror Mastic.
 - 2. Verify adhesives have a VOC content of 70 g/L or less.
 - 3. Verify adhesives comply with testing and product requirements of California Department of Public Health's "Standard Method for the Testing and Evaluation of Volatile Organic Chemical Emissions from Indoor Sources Using Environmental Chambers."
- E. Film Backing for Safety Mirrors: Film backing and pressure-sensitive adhesive; both compatible with mirror backing paint as certified by mirror manufacturer.

2.4 MIRROR HARDWARE

- A. Aluminum J-Channels and Cleat: Aluminum extrusions with a return deep enough to produce a glazing channel to accommodate mirrors of thickness indicated and in lengths required to cover edges of each mirror in a single piece.
 - 1. Bottom Trim: J-channels formed with front leg and back leg not less than 3/8 and 7/8 inch in height, respectively, and a thickness of not less than 0.04 inch.
 - a. Products: Subject to compliance with requirements, provide one of the following:
 - 1) Andscot Company, Inc.
 - 2) Laurence, C. R. Co., Inc.
 - 3) Stylemark, Inc.
 - 4) Approved substitution.
 - 2. Top Trim: J-channels formed with front leg and back leg not less than 5/8 and 1 inch in height, respectively, and a thickness of not less than 0.04 inch.
 - a. Products: Subject to compliance with requirements, provide products from one of the following:
 - 1) Andscot Company, Inc.
 - 2) Laurence, C. R. Co., Inc.
 - 3) Stylemark, Inc.
 - 4) Approved substitution.
- B. Fasteners: Bugle headed screws, stainless steel or chrome plated, designed to set flush with J-channel back leg.
 - 1. Provide appropriate fasteners for type of clip, size of mirror, and substrate.
- C. Anchors and Inserts: Provide devices as required for mirror hardware installation. Provide toothed or lead-shield expansion-bolt devices for drilled-in-place anchors. Provide galvanized anchors and inserts for applications on inside face of exterior walls and where indicated.

2.5 FABRICATION

- A. Fabricate mirrors in the shop to greatest extent possible.
- B. Mirror Sizes: To suit Project conditions, cut mirrors to final sizes and shapes.
 - 1. Cut mirrors before tempering.
- C. Fabricate cutouts for notches and holes in mirrors without marring visible surfaces. Locate and size cutouts so they fit closely around penetrations in mirrors.
 - 1. Fabricate cutouts before tempering.

- D. Mirror Edge Treatment: Do not provide unedged mirrors where edges are exposed.
 - 1. Exposed Perimeter Edges: Polished with round or beveled edge.
 - 2. Butt Edges: Flat polished for tight butt joints.
 - 3. Tempered Mirrors:
 - a. Seal edges of mirrors with edge sealer after edge treatment to prevent chemical or atmospheric penetration of glass coating.
 - b. Require mirror manufacturer to perform edge treatment and sealing in factory immediately after cutting to final sizes.

PART 3 - EXECUTION

3.1 EXAMINATION

- A. Examine substrates over which mirrors are to be mounted with Installer present for compliance with installation tolerances, substrate preparation, and other conditions affecting performance of Work.
- B. Verify compatibility with and suitability of substrates, including compatibility of existing finishes or primers with mirror mastic.
- C. Verify that anchorage devices embedded in permanent construction are correctly sized and located to accommodate mirrored acrylic glazing.
- D. Proceed with installation only after unsatisfactory conditions have been corrected and surfaces are dry.

3.2 PREPARATION

- A. Comply with mastic manufacturer's written installation instructions for preparation of substrates, including coating substrates with mastic manufacturer's special bond coating where applicable.

3.3 INSTALLATION

- A. General: Install mirrors to comply with mirror manufacturer's written instructions and with referenced GANA publications. Mount mirrors accurately in place in a manner that avoids distorting reflected images.
 - 1. GANA Publications: "Glazing Manual" and "Mirrors, Handle with Extreme Care: Tips for the Professional on the Care and Handling of Mirrors."
- B. Provide a minimum airspace of 1/8 inch between back of mirrors and mounting surface for air circulation between back of mirrors and face of mounting surface.
- C. Install mirrors with mastic and mirror hardware. Attach mirror hardware securely to mounting surfaces with mechanical fasteners installed with anchors or inserts as applicable. Install fasteners so heads do not impose point loads on backs of mirrors.
 - 1. Aluminum J-Channels and Cleat: Fasten J-channel directly to wall and attach top trim to continuous cleat fastened directly to wall.
 - 2. Install mastic as follows:
 - a. Apply barrier coat to mirror backing where approved in writing by manufacturers of mirrors and backing material.
 - b. Apply mastic to comply with mastic manufacturer's written instructions for coverage and to allow air circulation between back of mirrors and face of mounting surface.
 - c. After mastic is applied, align mirrors and press into place while maintaining a minimum airspace of 1/8 inch between back of mirrors and mounting surface.

3.4 CLEANING

- A. Clean exposed surface of mirrors not more than four days before date scheduled for inspections that establish date of Substantial Completion. Clean mirrors as recommended in writing by mirror manufacturer.

3.5 PROTECTION

- A. Protect mirrors from breakage and contaminating substances resulting from construction operations.
- B. Do not permit edges of mirrors to be exposed to standing water.
- C. Maintain environmental conditions that prevent mirrors from being exposed to moisture from condensation or other sources for continuous periods of time.

END OF SECTION 088300

SECTION 089119
FIXED LOUVERS

PART 1 - GENERAL

1.1 SUMMARY

- A. Section Includes:
1. Fixed extruded-aluminum louvers.
 2. Blank-off panels for louvers.

1.2 ACTION SUBMITTALS

- A. Product Data: For each type of product.
1. For louvers specified to bear AMCA seal, include printed catalog pages showing specified models with appropriate AMCA Certified Ratings Seals.
- B. Sustainable Design Submittals:
1. Environmental Product Declaration (EPD): For each product.
 2. Health Product Declaration (HPD): For each product.
 3. Sourcing of Raw Materials: Corporate sustainability report for each manufacturer.
- C. Shop Drawings: For louvers and accessories. Include plans, elevations, sections, details, and attachments to other Work. Show frame profiles and blade profiles, angles, and spacing.
1. Show weep paths, gaskets, flashings, sealants, and other means of preventing water intrusion.
 2. Show mullion profiles and locations.
- D. Samples for Verification: For each type of metal finish required.
- E. Delegated-Design Submittal: For louvers indicated to comply with structural and seismic performance requirements and design criteria, including analysis data signed and sealed by qualified professional engineer responsible for their preparation.

1.3 INFORMATIONAL SUBMITTALS

- A. Product Test Reports: Based on evaluation of comprehensive tests performed according to AMCA 500-L by a qualified testing agency or by manufacturer and witnessed by a qualified testing agency, for each type of louver and showing compliance with performance requirements specified.
- B. Sample Warranties: For manufacturer's special warranties.

1.4 QUALITY ASSURANCE

- A. Welding Qualifications: Qualify procedures and personnel according to the following:
1. AWS D1.2, "Structural Welding Code - Aluminum."

1.5 DELIVERY, STORAGE, AND HANDLING

- A. Deliver components, louvers, and other manufactured items so as not to be damaged or deformed. Package louvers for protection during transportation and handling.
- B. Retain strippable protective covering on metal panels during installation.

1.6 WARRANTY

- A. Manufacturer's Warranty: Manufacturer agrees to repair or replace components of louvers that fail in materials or workmanship within specified warranty period.
 - 1. Warranty Period: 5 years from date of Substantial Completion.
- B. Special Finish Warranty: Manufacturer agrees to repair or replace components on which finishes fail in materials or workmanship within specified warranty period.
 - 1. Deterioration includes the following:
 - a. Color fading more than 5 Hunter units when tested according to ASTM D2244.
 - b. Chalking in excess of a No. 8 rating when tested according to ASTM D4214.
 - c. Cracking, checking, peeling, or failure of paint to adhere to bare metal.
 - 2. Warranty Period: 20 years from date of Substantial Completion.

PART 2 - PRODUCTS

2.1 MANUFACTURERS

- A. Source Limitations: Obtain louvers from single source from a single manufacturer where indicated to be of same type, design, or factory-applied color finish.

2.2 PERFORMANCE CRITERIA

- A. Delegated Design: Design louvers, including comprehensive engineering analysis, by a qualified professional engineer, using structural and seismic performance requirements and design criteria indicated.
- B. Structural Performance: Louvers shall withstand effects of gravity loads and the following loads and stresses within limits and under conditions indicated without permanent deformation of louver components, noise or metal fatigue caused by louver-blade rattle or flutter, or permanent damage to fasteners and anchors. Wind pressures shall be considered to act normal to face of building.
 - 1. Wind Loads: Determine loads based on a uniform pressure of 20 lbf/sq. ft., acting inward or outward unless indicated otherwise on Drawings.
- C. Seismic Performance: Louvers, including attachments to other construction, shall withstand effects of earthquake motions determined according to ASCE/SEI 7.
 - 1. Component Importance Factor: 1.0.
- D. Louver Performance Ratings: Provide louvers complying with requirements specified, as demonstrated by testing manufacturer's stock units identical to those provided, except for length and width according to AMCA 500-L.
- E. Thermal Movements: Allow for thermal movements from ambient and surface temperature changes.
 - 1. Temperature Change (Range): 120 deg F, ambient; 180 deg F, material surfaces.
- F. SMACNA Standard: Comply with recommendations in SMACNA's "Architectural Sheet Metal Manual" for fabrication, construction details, and installation procedures.

2.3 FIXED EXTRUDED-ALUMINUM LOUVERS

- A. Horizontal, Drainable-Blade Louver (LOUVER-1):
 - 1. Basis-of-Design Product: Subject to compliance with requirements, provide the following:
 - a. Ruskin Company: Model ELF445DXH.
 - b. Approved substitution from one of the following:
 - 1) Airolite Company, LLC (The).
 - 2) Construction Specialties, Inc.
 - 3) Greenheck Fan Corporation.

- 4) Industrial Louvers, Inc.
- 5) Nystrom, Inc.
- 6) Reliable Products, Inc.
2. Louver Depth: 4 inches.
3. Blade Profile: Plain blade without center baffle; 45 degree angle.
4. Blade Spacing: 4 inches on center.
5. Frame and Blade Nominal Thickness: Not less than 0.125 inch for blades and frames.
6. Mullion Type: Fully recessed.
7. Louver Performance Ratings:
 - a. Free Area: Not less than 52 percent for 48 inch wide by 48 inch high louver.
 - b. Free Area Size: 8.34 sq. ft. nominal.
 - c. Air Performance:
 - 1) Air Flow Through Free Area: Maximum 1,075 fpm free-area intake velocity.
 - 2) Static Pressure Drop (Intake): Not more than 0.225 inch wg.
 - 3) Water Penetration: Maximum of 0.01 oz./sq. ft. of free area at maximum 1,075 fpm free-area intake velocity when tested for 15 minutes.
 - 4) Air Flow: 8,966 cfm.
8. AMCA Seal: Mark units with AMCA Certified Ratings Seal.

2.4 LOUVER SCREENS

- A. General: Provide screen at each exterior louver.
 1. Screen Location for Fixed Louvers: Interior face.
 2. Screening Type: Bird screening, except where insect screening is indicated.
- B. Secure screen frames to louver frames with machine screws with heads finished to match louver, spaced a maximum of 6 inches from each corner and at 12 inches on center.
- C. Louver Screen Frames: Fabricate with mitered corners to louver sizes indicated.
 1. Metal: Same kind and form of metal as indicated for louver to which screens are attached.
 2. Finish: Same finish as louver frames to which louver screens are attached.
- D. Louver Screening for Aluminum Louvers:
 1. Bird Screening: Aluminum, 1/2 inch square mesh, 0.063 inch wire.

2.5 BLANK-OFF PANELS

- A. Uninsulated Blank-Off Panels: Metal sheet attached to back of louver.
 1. Aluminum sheet for aluminum louvers, not less than 0.050 inch nominal thickness.
 2. Panel Finish: Same finish applied to louvers.
 3. Attach blank-off panels with sheet metal screws.
- B. Insulated, Blank-Off Panels: Laminated panels consisting of an insulating core surfaced on back and front with metal sheets and attached to back of louver.
 1. Thickness: 2 inches.
 2. Metal Facing Sheets: Aluminum sheet, not less than 0.032 inch nominal thickness.
 3. Insulating Core: Rigid, glass-fiber-board insulation.
 4. Edge Treatment: Trim perimeter edges of blank-off panels with louver manufacturer's standard extruded-aluminum-channel frames, not less than 0.080 inch nominal thickness, with corners mitered and with same finish as panels.
 5. Seal perimeter joints between panel faces and louver frames with gaskets or sealant.
 6. Panel Finish: Same finish applied to louvers.
 7. Attach blank-off panels with sheet metal screws.

2.6 MATERIALS

- A. Aluminum Extrusions: ASTM B221, Alloy 6063-T5, T-52, or T6.
- B. Aluminum Sheet: ASTM B209, Alloy 3003 or 5005, with temper as required for forming, or as otherwise recommended by metal producer for required finish.
- C. Fasteners: Use types and sizes to suit unit installation conditions.
 - 1. Use tamper-resistant screws for exposed fasteners unless otherwise indicated.
 - 2. For fastening aluminum, use aluminum or 300 series stainless-steel fasteners.
 - 3. For fastening galvanized steel, use hot-dip-galvanized-steel or 300 series stainless-steel fasteners.
 - 4. For color-finished louvers, use fasteners with heads that match color of louvers.
- D. Postinstalled Fasteners for Concrete and Masonry: Torque-controlled expansion anchors, fabricated from stainless-steel components, with allowable load or strength design capacities calculated according to ICC-ES AC193 and ACI 318 greater than or equal to the design load, as determined by testing according to ASTM E488 conducted by a qualified testing agency.
- E. Bituminous Paint: Cold-applied asphalt emulsion complying with ASTM D1187.
- F. Recycled Content of Aluminum Components: Postconsumer recycled content plus 1/2 of preconsumer recycled content not less than 50 percent.

2.7 FABRICATION

- A. Factory assemble louvers to minimize field splicing and assembly. Disassemble units as necessary for shipping and handling limitations. Clearly mark units for reassembly and coordinated installation.
- B. Vertical Assemblies: Where height of louver units exceeds fabrication and handling limitations, fabricate units to permit field-bolted assembly with close-fitting joints in jambs and mullions, reinforced with splice plates.
 - 1. Continuous Vertical Assemblies: Fabricate units without interrupting blade-spacing pattern unless horizontal mullions are indicated.
- C. Maintain equal louver blade spacing, including separation between blades and frames at head and sill, to produce uniform appearance.
- D. Fabricate frames, including integral sills, to fit in openings of sizes indicated, with allowances made for fabrication and installation tolerances, adjoining material tolerances, and perimeter sealant joints.
 - 1. Frame Type: [**Channel**] [**Exterior flange**] [**Interior flange**] unless otherwise indicated.
- E. Include supports, anchorages, and accessories required for complete assembly.
- F. Provide vertical mullions of type and at spacings indicated, but not more than is recommended by manufacturer, or 72 inches on center, whichever is less.
 - 1. Fully Recessed Mullions: Where indicated, provide mullions fully recessed behind louver blades. Where length of louver exceeds fabrication and handling limitations, fabricate with close-fitting blade splices designed to permit expansion and contraction.
 - 2. Exposed Mullions: Where indicated, provide units with exposed mullions of same width and depth as louver frame. Where length of louver exceeds fabrication and handling limitations, provide interlocking split mullions designed to permit expansion and contraction.
- G. Provide subsills made of same material as louvers for recessed louvers.
- H. Join frame members to each other and to fixed louver blades with fillet welds concealed from view, threaded fasteners, or both, as standard with louver manufacturer unless otherwise indicated or size of louver assembly makes bolted connections between frame members necessary.

2.8 FINISHES, GENERAL

- A. Protect mechanical and painted finishes on exposed surfaces from damage by applying a strippable, temporary, protective covering before shipping.

2.9 ALUMINUM FINISHES

- A. Finish louvers after assembly.
- B. High-Performance Organic Finish: 3-coat fluoropolymer finish complying with AAMA 2605 and containing not less than 70 percent PVDF resin by weight in both color coat and clear topcoat. Prepare, pretreat, and apply coating to exposed metal surfaces to comply with coating and resin manufacturers' written instructions.
 - 1. Color and Gloss: As selected by Architect from manufacturer's full range.

PART 3 - EXECUTION

3.1 EXAMINATION

- A. Examine substrates and openings, with Installer present, for compliance with requirements for installation tolerances and other conditions affecting performance of the Work.
- B. Proceed with installation only after unsatisfactory conditions have been corrected.

3.2 PREPARATION

- A. Coordinate setting drawings, diagrams, templates, instructions, and directions for installation of anchorages that are to be embedded in concrete or masonry construction. Coordinate delivery of such items to Project site.

3.3 INSTALLATION

- A. Locate and place louvers level, plumb, and at indicated alignment with adjacent Work.
- B. Use concealed anchorages where possible. Provide brass or lead washers fitted to screws where required to protect metal surfaces and to make a weathertight connection.
- C. Form closely fitted joints with exposed connections accurately located and secured.
- D. Provide perimeter reveals and openings of uniform width for sealants and joint fillers, as indicated.
- E. Protect unpainted galvanized- and nonferrous-metal surfaces that are in contact with concrete, masonry, or dissimilar metals from corrosion and galvanic action by applying a heavy coating of bituminous paint or by separating surfaces with waterproof gaskets or nonmetallic flashing.
- F. Install concealed gaskets, flashings, joint fillers, and insulation as louver installation progresses, where weathertight louver joints are required. Comply with Section 079200 – Joint Sealants for sealants applied during louver installation.

3.4 REPAIR

- A. Restore louvers damaged during installation and construction so no evidence remains of corrective Work. If results of restoration are unsuccessful, as determined by Architect, remove damaged units and replace with new units.
 - 1. Touch up minor abrasions in finishes with air-dried coating that matches color and gloss of, and is compatible with, factory-applied finish coating.

3.5 CLEANING

- A. Remove temporary protective coverings and strippable films, if any, as louvers are installed unless otherwise indicated in manufacturer's written installation instructions. On completion of louver installation, clean finished surfaces as recommended by louver manufacturer. Maintain in a clean condition during construction. Do not let soil accumulate during construction period.
- B. Before final inspection, clean exposed surfaces with water and a mild soap or detergent not harmful to finishes. Thoroughly rinse surfaces and dry.

END OF SECTION 089119

SECTION 092116
GYPSUM BOARD SHAFT WALL ASSEMBLIES

PART 1 - GENERAL

1.1 SUMMARY

- A. Section Includes:
 - 1. Gypsum board shaft wall assemblies.

1.2 ACTION SUBMITTALS

- A. Product Data: For each component of gypsum board shaft wall assembly.
- B. Sustainable Design Submittals:
 - 1. Environmental Product Declaration (EPD): For each product.

1.3 DELIVERY, STORAGE, AND HANDLING

- A. Store materials inside under cover and keep them dry and protected against weather, condensation, direct sunlight, construction traffic, and other potential causes of damage. Stack panels flat and support them on risers on a flat platform to prevent sagging.

1.4 FIELD CONDITIONS

- A. Environmental Limitations: Comply with gypsum-shaftliner-board manufacturer's written instructions.
- B. Do not install finish panels until installation areas are enclosed and conditioned.
- C. Do not install panels that are wet, moisture damaged, or mold damaged.
 - 1. Indications that panels are wet or moisture damaged include, but are not limited to, discoloration, sagging, and irregular shape.
 - 2. Indications that panels are mold damaged include, but are not limited to, fuzzy or splotchy surface contamination and discoloration.

PART 2 - PRODUCTS

2.1 PERFORMANCE CRITERIA

- A. Fire-Resistance-Rated Assemblies: For fire-resistance-rated assemblies, provide materials and construction identical to those tested in assembly indicated according to ASTM E119 by an independent testing agency.
- B. STC-Rated Assemblies: Provide materials and construction identical to those of assemblies tested according to ASTM E90 and classified according to ASTM E413 by a testing and inspecting agency.
 - 1. STC Rating: Minimum 50.
- C. Design Air Pressure: Design HVAC and elevator shafts to meet a sustained air pressure load of 5 lbf/sq. ft. with maximum mid-span deflection of L/240.
- D. Recycled Content: Postconsumer recycled content plus 1/2 of preconsumer recycled content not less than 25 percent.

2.2 GYPSUM BOARD SHAFT WALL ASSEMBLIES

- A. Fire-Resistance Rating: As indicated on Drawings.
- B. Gypsum Shaftliner Board:
 - 1. Type X: ASTM C1396; manufacturer's proprietary fire-resistive liner panels with paper faces.
 - a. Products: Subject to compliance with requirements, provide one of the following:
 - 1) American Gypsum: Shaft Liner Panels.
 - 2) CertainTeed Corporation: ProRoc Shaftliner.
 - 3) Georgia-Pacific Gypsum LLC: ToughRock Fireguard Shaftliner.
 - 4) National Gypsum Company: Gold Bond Fire-Shield Shaftliner.
 - 5) USG Corporation: Sheetrock Brand Gypsum Liner Panel.
 - 6) Approved substitution.
 - b. Thickness: 1 inch.
 - c. Edges: Double beveled long edges.
 - 2. Moisture- and Mold-Resistant Type X: ASTM C1396; manufacturer's proprietary fire-resistive liner panels.
 - a. Products: Subject to compliance with requirements, provide one of the following:
 - 1) American Gypsum: M-Bloc Shaft Liner with Mold & Moisture Resistance.
 - 2) CertainTeed Corporation: ProRoc Moisture and Mold Resistant Shaftliner.
 - 3) Georgia-Pacific Gypsum LLC: Dens-Glass Ultra Shaftliner.
 - 4) National Gypsum Company: Gold Bond Shaftliner XP Gypsum Board.
 - 5) USG Corporation: Sheetrock Brand Mold Tough Gypsum Liner Panel.
 - 6) Approved substitution.
 - b. Mold-Resistance Score: ASTM D3273; 10 as rated according to ASTM D3274.
 - c. Thickness: 1 inch.
 - d. Edges: Double beveled long edges.
- C. Non-Load-Bearing Steel Framing, General: Complying with ASTM C645 requirements for metal unless otherwise indicated and complying with requirements for fire-resistance-rated assembly indicated.
 - 1. Protective Coating: ASTM A653, G60, hot-dip galvanized unless otherwise indicated.
- D. Studs: Manufacturer's standard profile for repetitive, corner, and end members as follows:
 - 1. Depth: As indicated on Drawings.
 - 2. Minimum Base-Metal Thickness: 0.0296 inch (30 mils) unless indicated otherwise.
- E. Runner Tracks: Manufacturer's standard J-profile track with manufacturer's standard long-leg length, but at least 2 inches long and matching studs in depth.
 - 1. Minimum Base-Metal Thickness: Matching steel studs.
- F. Elevator-Hoistway-Entrance Struts: Manufacturer's standard J-profile jamb strut with long-leg length of 3 inches, matching studs in depth, and not less than 0.033 inch thick.
- G. Shaft-Side Finish: Gypsum shaftliner board, moisture- and mold-resistant Type X and as indicated by fire-resistance-rated assembly design designation.
- H. Finish Panels: Gypsum board as specified in Section 092900 – Gypsum Board.
- I. Sound Attenuation Blankets: As specified in Section 092900 – Gypsum Board.

2.3 AUXILIARY MATERIALS

- A. Provide auxiliary materials that comply with shaft wall manufacturer's written instructions.
- B. Trim Accessories: Cornerbead, edge trim, and control joints of material and shapes as specified in Section 092900 – Gypsum Board that comply with gypsum board shaft wall assembly manufacturer's written instructions for application indicated.

- C. Steel Drill Screws: ASTM C1002 unless otherwise indicated.
- D. Track Fasteners: Power-driven fasteners of size and material required to withstand loading conditions imposed on shaft wall assemblies without exceeding allowable design stress of track, fasteners, or structural substrates in which anchors are embedded.
 - 1. Expansion Anchors: Fabricated from corrosion-resistant materials, with allowable load or strength design capacities calculated according to ICC-ES AC193 and ACI 318 greater than or equal to the design load, as determined by testing per ASTM E488 conducted by a qualified testing agency.
 - 2. Power-Actuated Anchors: Fastener system of type suitable for application indicated, fabricated from corrosion-resistant materials, with allowable load capacities calculated according to ICC-ES AC70, greater than or equal to the design load, as determined by testing per ASTM E1190 conducted by a qualified testing agency.
- E. Reinforcing: Galvanized-steel reinforcing strips with 0.033 inch thick minimum thickness of base metal (uncoated).
- F. Acoustical Sealant: Section 079219 – Acoustical Joint Sealants.

PART 3 - EXECUTION

3.1 EXAMINATION

- A. Examine substrates and conditions, with Installer present, for compliance with requirements for installation tolerances and other conditions affecting performance of Work.
- B. Examine panels before installation. Reject panels that are wet, moisture damaged, or mold damaged.
- C. Proceed with installation only after unsatisfactory conditions have been corrected.

3.2 PREPARATION

- A. Sprayed Fire-Resistive Materials: Coordinate with gypsum board shaft wall assemblies so both elements of Work remain complete and undamaged. Patch or replace sprayed fire-resistive materials removed or damaged during installation of shaft wall assemblies to comply with requirements specified in Section 078100 – Applied Fire Protection.
- B. After sprayed fire-resistive materials are applied, remove only to extent necessary for installation of gypsum board shaft wall assemblies and without reducing the fire-resistive material thickness below that which is required to obtain fire-resistance rating indicated. Protect remaining fire-resistive materials from damage.

3.3 INSTALLATION

- A. General: Install gypsum board shaft wall assemblies to comply with requirements of fire-resistance-rated assemblies indicated and manufacturer's written installation instructions.
- B. Do not bridge building expansion joints with shaft wall assemblies; frame both sides of expansion joints with furring and other support.
- C. Install supplementary framing in gypsum board shaft wall assemblies around openings and as required for blocking, bracing, and support of gravity and pullout loads of fixtures, equipment, services, heavy trim, furnishings, wall-mounted door stops, and similar items that cannot be supported directly by shaft wall assembly framing.
 - 1. Elevator Hoistway: At elevator hoistway-entrance door frames, provide jamb struts on each side of door frame.

2. Reinforcing: Provide where items attach directly to shaft wall assembly as indicated on Drawings; accurately position and secure behind at least one layer of face panel.
 - D. Penetrations: At penetrations in shaft wall, maintain fire-resistance rating of shaft wall assembly by installing supplementary steel framing around perimeter of penetration and fire protection behind boxes containing wiring devices, elevator call buttons and floor indicators, and similar items.
 - E. Isolate perimeter of gypsum panels from building structure to prevent cracking of panels while maintaining continuity of fire-rated construction.
 - F. Control Joints: Install control joints according to ASTM C840 and in specific locations approved by Architect while maintaining fire-resistance rating of gypsum board shaft wall assemblies.
 - G. Sound-Rated Shaft Wall Assemblies: Seal gypsum board shaft walls with acoustical sealant at perimeter of each assembly where it abuts other Work and at joints and penetrations within each assembly.
 - H. Installation Tolerance: Install each framing member so fastening surfaces vary not more than 1/8 inch from plane formed by faces of adjacent framing.
- 3.4 PROTECTION
- A. Protect installed products from damage from weather, condensation, direct sunlight, construction, and other causes during remainder of the construction period.
 - B. Remove and replace panels that are wet, moisture damaged, or mold damaged.
 1. Indications that panels are wet or moisture damaged include discoloration, sagging, and irregular shape.
 2. Indications that panels are mold damaged include fuzzy or splotchy surface contamination and discoloration.

END OF SECTION 092116

SECTION 092900

GYPSUM BOARD

PART 1 - GENERAL

1.1 SUMMARY

- A. Section Includes:
 - 1. Gypsum board panels.
 - 2. Tile backing panels.
 - 3. Sound attenuation blankets.

1.2 ACTION SUBMITTALS

- A. Product Data: For each product indicated.
- B. Sustainable Design Submittals:
 - 1. Product Data: For adhesives and sealants, indicating VOC content.
 - 2. Laboratory Test Reports: For adhesives and sealants, indicating compliance with requirements for low-emitting materials.
 - 3. Laboratory Test Reports: For ceiling and wall materials, indicating compliance with requirements for low-emitting materials.
- C. Samples for Verification: For the following products:
 - 1. Trim Accessories: Full-size Sample in 12 inch long length for each trim accessory indicated.
 - 2. Textured Finishes: Manufacturer's standard size for each textured finish indicated and on same backing indicated for Work.

1.3 QUALITY ASSURANCE

- A. Installer Qualifications: Company specializing in performing gypsum board application and finishing, with minimum 3 years of documented experience.
- B. Mockups: Build mockups in compliance with Section 014339 – Mockups to demonstrate aesthetic effects, and to set quality standards for materials and execution.
 - 1. Build mockups of at least 100 sq. ft. in surface area for the following:
 - 2. Build mockups for the following:
 - a. Each level of gypsum board finish indicated for use in exposed locations.
 - b. Each texture finish indicated.
 - 3. Apply or install final decoration indicated, including painting and wallcoverings, on exposed surfaces for review of mockups.
 - 4. Simulate finished lighting conditions for review of mockups.
 - 5. Subject to compliance with requirements, approved mockups may become part of the completed Work if undisturbed at time of Substantial Completion.

1.4 DELIVERY, STORAGE, AND HANDLING

- A. Store materials inside under cover and keep them dry and protected against weather, condensation, direct sunlight, construction traffic, and other potential causes of damage. Stack panels flat and supported on risers on a flat platform to prevent sagging.

1.5 FIELD CONDITIONS

- A. Environmental Limitations: Comply with ASTM C840 requirements or gypsum board manufacturer's written recommendations, whichever are more stringent.
- B. Do not install paper-faced gypsum panels until installation areas are enclosed and conditioned.
- C. Do not install panels that are wet, those that are moisture damaged, and those that are mold damaged.
 - 1. Indications that panels are wet or moisture damaged include discoloration, sagging, or irregular shape.
 - 2. Indications that panels are mold damaged include fuzzy or splotchy surface contamination and discoloration.

PART 2 - PRODUCTS

2.1 PERFORMANCE CRITERIA

- A. Fire-Resistance-Rated Assemblies: For fire-resistance-rated assemblies, provide materials and construction identical to those tested in assembly indicated per ASTM E119 by an independent testing agency.
- B. STC-Rated Assemblies: For STC-rated assemblies, provide materials and construction identical to those tested in assembly indicated per ASTM E90 and classified per ASTM E413 by an independent testing agency.
- C. Verify ceiling and wall materials comply with requirements of California Department of Public Health's "Standard Method for the Testing and Evaluation of Volatile Organic Chemical Emissions from Indoor Sources Using Environmental Chambers."

2.2 GYPSUM BOARD, GENERAL

- A. Recycled Content: Postconsumer recycled content plus 1/2 of preconsumer recycled content not less than 20 percent.
- B. Size: Provide in maximum lengths and widths available that will minimize joints in each area and that correspond with support system indicated.

2.3 INTERIOR GYPSUM BOARD

- A. Gypsum Board, Type X: ASTM C1396; surfaced with 100 percent recycled content paper on front, back, and long edges.
 - 1. Products: Subject to compliance with requirements, provide one of the following:
 - a. CertainTeed Gypsum, Inc.: CertainTeed Type X.
 - b. Georgia-Pacific Gypsum LLC: ToughRock Fireguard X.
 - c. National Gypsum Company: Gold Bond Brand Fire-Shield.
 - d. USG Corporation: USG Sheetrock Brand Firecode X or EcoSmart Panels Firecode X.
 - e. Approved substitution.
 - 2. Thickness: 5/8 inch.
 - 3. Edges: Tapered and featured (rounded or beveled) for prefilling.

- B. Moisture- and Mold-Resistant Gypsum Board: ASTM C1396; with moisture- and mold-resistant core and paper surfaces.
 - 1. Products: Subject to compliance with requirements, provide one of the following:
 - a. CertainTeed Gypsum, Inc.: CertainTeed M2Tech Type X Gypsum Board.
 - b. Georgia-Pacific Gypsum LLC: ToughRock Fireguard X Mold-Guard.
 - c. National Gypsum Company: Gold Bond XP Fire-Shield Gypsum Board.
 - d. USG Corporation: USG Sheetrock Brand Mold Tough Firecode X Panels.
 - e. Approved substitution.
 - 2. Core: 5/8 inch, Type X.
 - 3. Long Edges: Tapered.
 - 4. Mold Resistance: ASTM D3273, score of 10 as rated according to ASTM D3274.

2.4 SPECIALTY GYPSUM BOARD

- A. Exterior Gypsum Soffit Board: ASTM C1396, with manufacturer's standard edges.
 - 1. Products: Subject to compliance with requirements, provide one of the following:
 - a. CertainTeed Gypsum, Inc.: Exterior Soffit Type X.
 - b. Georgia-Pacific Gypsum LLC: ToughRock Fireguard C Soffit Board.
 - c. National Gypsum Company: Gold Bond Brand Fire-Shield Exterior Soffit Board.
 - d. USG Corporation: USG Sheetrock Brand Exterior Gypsum Ceiling Board
 - e. Approved substitution.
 - 2. Core: 5/8 inch, Type X.
- B. Exterior Glass-Mat Gypsum Sheathing Board: Specified in Section 061600 - Sheathing.
- C. Shaft-Wall Core-Board: Specified in Section 092119 – Gypsum Board Shaft Wall Assemblies.

2.5 TILE BACKING PANELS

- A. Glass-Mat, Water-Resistant Backing Board: ASTM C1178, with manufacturer's standard edges.
 - 1. Products: Subject to compliance with requirements, provide one of the following:
 - a. CertainTeed Gypsum, Inc.: CertainTeed GlaRoc Tile Backer.
 - b. Georgia-Pacific Gypsum LLC: DensShield Tile Backer.
 - c. National Gypsum Company: Gold Bond eXP Tile Backer.
 - d. USG Corporation: USG Durock Glass-Mat Tile Backerboard.
 - e. Approved substitution.
 - 2. Core: 5/8 inch, Type X.
 - 3. Mold Resistance: Score of 10 as rated per ASTM D3273.
 - 4. Core: 5/8 inch, Type X.
 - 5. Mold Resistance: ASTM D3273, score of 10 as rated according to ASTM D3274.

2.6 TRIM ACCESSORIES

- A. Interior Trim: ASTM C1047.
 - 1. Material: Galvanized steel sheet.
 - 2. Shapes: As required for conditions indicated on Drawings.
- B. Expansion (Control) Joints: Galvanized or aluminum-coated steel sheet, rolled zinc, plastic, or paper-faced galvanized steel sheet control joint with 1/2 to 3/4 inch grounds for drywall finishes. Staple or screw grounds to panel face.
 - 1. Application: Interior gypsum board walls and ceilings.
 - 2. Where fire and sound control joints are indicated, provide fire rated seal behind control joint.

2.7 JOINT TREATMENT MATERIALS

- A. General: Comply with ASTM C475.
- B. Joint Tape:
 - 1. Interior Gypsum Board: Paper.
 - 2. Tile Backing Panels: As recommended by panel manufacturer.
- C. Joint Compound for Interior Gypsum Board: For each coat use formulation that is compatible with other compounds applied on previous or for successive coats.
 - 1. Prefilling: At open joints, beveled panel edges, and damaged surface areas, use setting-type taping compound.
 - 2. Embedding and First Coat: or embedding tape and first coat on joints, fasteners, and trim flanges, use setting-type taping compound.
 - a. Use setting-type compound for installing paper-faced metal trim accessories.
 - 3. Fill Coat: For second coat, use drying-type, all-purpose compound.
 - 4. Finish Coat: For third coat, use drying-type, all-purpose compound.
 - 5. Skim Coat: For final coat of Level 5 finish, use drying-type, all-purpose compound.
- D. Joint Compound for Tile Backing Panels:
 - 1. Glass-Mat, Water-Resistant Backing Panel: As recommended by backing panel manufacturer.

2.8 AUXILIARY MATERIALS

- A. General: Provide auxiliary materials that comply with referenced installation standards and manufacturer's written recommendations.
- B. Steel Drill Screws: ASTM C1002, unless otherwise indicated.
 - 1. Use screws complying with ASTM C954 for fastening panels to steel members from 0.033 to 0.112 inch thick.

2.9 SOUND ATTENUATION INSULATION

- A. Sound Attenuation Blankets: ASTM C665, Type I (blankets without membrane facing) produced by combining thermosetting resins with mineral fibers manufactured from glass, slag wool, or rock wool.
 - 1. Products: Subject to compliance with requirements, provide one of the following:
 - a. CertainTeed Gypsum, Inc.: CertaPro AcoustaTherm Batts.
 - b. Johns Manville: Sound Control Batts.
 - c. Knauf Insulation: QuietTherm Acoustical/Thermal Batt Insulation.
 - d. Owens Corning: Fiberglas Unfaced Sound Attenuation Blankets.
 - e. Roxul Inc.: AFB.
 - f. Approved substitution.
 - 2. Fire-Resistance-Rated Assemblies: Comply with mineral-fiber requirements of assembly.
 - 3. Recycled Content: Postconsumer recycled content plus 1/2 of preconsumer recycled content not less than 50 percent.
 - 4. Surface-Burning Characteristics: Comply with ASTM E84; testing by qualified testing agency
 - a. Flame-Spread Index: 25 or less.
 - b. Smoke-Developed Index: 50 or less.
- B. Acoustical Joint Sealant: Specified in Section 079219 – Acoustical Joint Sealants.

2.10 TEXTURE FINISHES

- A. Primer: As recommended by textured finish manufacturer.

- B. Aggregate Finish: Water-based, job-mixed, polystyrene aggregate finish.
 - 1. Products: Subject to compliance with requirements, provide one of the following:
 - a. Georgia-Pacific Gypsum LLC: ToughRock Regency Ceiling Textures/Polystyrene.
 - b. National Gypsum Company: ProForm Perfect Spray Medium Aggregate Texture Spray.
 - c. USG Corporation: SHEETROCK Ceiling Spray Texture, QT.
 - d. Approved substitution.
 - 2. Texture: Medium [**Fine**] [**Coarse**].
 - 3. Surface-Burning Characteristics: Comply with ASTM E84; testing by qualified testing agency.
 - a. Flame-Spread Index: 25 or less.
 - b. Smoke-Developed Index: 25 or less.
 - 4. Applications: Residential ceilings over Level 4 gypsum board finish.
- C. Non-Aggregate Finish: Premixed, vinyl texture finish for spray application.
 - 1. Products: Subject to compliance with requirements, provide one of the following:
 - a. CertainTeed Corp.: ProRoc Easi-Tex Spray Texture.
 - b. National Gypsum Company: ProForm Perfect Spray EM Texture.
 - c. USG Corporation: BEADEX FasTex Wall and Ceiling Spray Texture.
 - d. Approved substitution.
 - 2. Texture: Orange peel.
 - 3. Applications: Residential walls over Level 4 gypsum board finish.

PART 3 - EXECUTION

3.1 EXAMINATION

- A. Examine areas and substrates, including welded hollow-metal frames and framing, with Installer present, for compliance with requirements and other conditions affecting performance.
- B. Examine panels before installation. Reject panels that are wet, moisture damaged, and mold damaged.
 - 1. Proceed with installation only after unsatisfactory conditions have been corrected.

3.2 INSTALLATION AND FINISHING PANELS, GENERAL

- A. Comply with ASTM C840.
- B. Install ceiling panels across framing to minimize number of abutting end joints and to avoid abutting end joints in central area of each ceiling. Stagger abutting end joints of adjacent panels not less than 1 framing member.
- C. Install panels with face side out. Butt panels together for a light contact at edges and ends with not more than 1/16 inch of open space between panels. Do not force into place.
- D. Locate edge and end joints over supports, except in ceiling applications where intermediate supports or gypsum board back-blocking is provided behind end joints. Do not place tapered edges against cut edges or ends. Stagger vertical joints on opposite sides of partitions. Do not make joints other than control joints at corners of framed openings.
- E. Form control and expansion joints with space between edges of adjoining gypsum panels.
- F. Cover both faces of support framing with gypsum panels in concealed spaces (above ceilings, etc.), except in chases braced internally.
 - 1. Unless concealed application is indicated or required for sound, fire, air, or smoke ratings, coverage may be accomplished with scraps of not less than 8 square feet in area.
 - 2. Fit gypsum panels around ducts, pipes, and conduits.

3. Where partitions intersect structural members projecting below underside of floor/roof slabs and decks, cut gypsum panels to fit profile formed by structural members; allow 1/4 to 3/8 inch wide joints to install sealant.
 - G. Isolate perimeter of gypsum board applied to non-load-bearing partitions at structural abutments, except floors. Provide 1/4 to 1/2 inch wide spaces at these locations, and trim edges with edge trim where edges of panels are exposed. Seal joints between edges and abutting structural surfaces with acoustical sealant.
 - H. Wood Framing: Install gypsum panels over wood framing, with floating internal corner construction. Do not attach gypsum panels across flat grain of wide-dimension lumber, including floor joists and headers. Float gypsum panels over these members, or provide control joints to counteract wood shrinkage.
- 3.3 INSTALLATION OF STC-RATED ASSEMBLIES
- A. Provide materials as required by gypsum panel system manufacturers to achieve laboratory Sound Transmission Class (STC) ratings indicated.
 - B. Install sound attenuation blankets before installing gypsum panels, unless blankets are readily installed after panels have been installed on 1 side.
 - C. Do not install gypsum panel layers continuous between 2 adjacent rooms.
 - D. STC-Rated Assemblies: Seal construction according to requirements specified in Section 079219.
- 3.4 INSTALLATION OF INTERIOR GYPSUM BOARD
- A. Install interior gypsum board in the following locations:
 1. Type X: Vertical surfaces unless indicated otherwise, including fire-resistance-rated assemblies and ceiling surfaces.
 2. Moisture- and Mold-Resistant Type: Walls subject to moisture exposure such as kitchens, toilets, behind drinking fountains, utility areas, and as indicated on Drawings.
 - B. Single-Layer Application:
 1. On ceilings, apply gypsum panels before wall/partition board application to greatest extent possible and at right angles to framing unless otherwise indicated.
 2. On partitions/walls, apply gypsum panels horizontally (perpendicular to framing) unless otherwise indicated or required by fire-resistance-rated assembly, and minimize end joints.
 - a. Stagger abutting end joints not less than one framing member in alternate courses of panels.
 - b. At stairwells and other high walls, install panels horizontally unless otherwise indicated or required by fire-resistance-rated assembly.
 3. On Z-furring members, apply gypsum panels vertically (parallel to framing) with no end joints. Locate edge joints over furring members.
 4. Fastening Methods: Apply gypsum panels to supports with steel drill screws.
 - C. Multilayer Application:
 1. On ceilings, apply gypsum board indicated for base layers before applying base layers on walls/partitions; apply face layers in same sequence. Apply base layers at right angles to framing members and offset face-layer joints one framing member, 16 inches minimum, from parallel base-layer joints, unless otherwise indicated or required by fire-resistance-rated assembly.

2. On partitions/walls, apply gypsum board indicated for base layers and face layers vertically (parallel to framing) with joints of base layers located over stud or furring member and face-layer joints offset at least one stud or furring member with base-layer joints, unless otherwise indicated or required by fire-resistance-rated assembly. Stagger joints on opposite sides of partitions.
3. On Z-furring members, apply base layer vertically (parallel to framing) and face layer either vertically (parallel to framing) or horizontally (perpendicular to framing) with vertical joints offset at least one furring member. Locate edge joints of base layer over furring members.
4. Fastening Methods: Fasten base layers and face layers separately to supports with screws; fasten face layers with adhesive and supplementary fasteners if required to comply with fire-rated assembly design.

3.5 INSTALLATION OF TILE BACKING PANELS

- A. Glass-Mat, Water-Resistant Backing Panels: Comply with manufacturer's written installation instructions and install at showers, tubs, and where indicated. Install with 1/4 inch gap where panels abut other construction or penetrations.
- B. Where tile backing panels abut other types of panels in same plane, shim surfaces to produce a uniform plane across panel surfaces.

3.6 INSTALLATION OF TRIM ACCESSORIES

- A. General: For trim with back flanges intended for fasteners, attach to framing with same fasteners used for panels. Otherwise, attach trim per manufacturer's written instructions.
- B. Control (Expansion) Joints: Install control joints per ASTM C840, and in specific locations approved by Architect for visual effect.
 1. Minimum Control Joint Spacing: 30 feet on center each way.
 2. Minimum Joint Spacing Between Panels: 1/4 inch.
- C. Interior Trim: Install in the following locations:
 1. Cornerbead: Use at outside corners, unless otherwise indicated.
 2. Bullnose Bead: Use at outside corners or where indicated.
 3. LC-Bead: Use at exposed panel edges.
 4. L-Bead: Use where indicated.
 5. U-Bead: Use at exposed panel edges or where indicated.
 6. Curved-Edge Cornerbead: Use at curved openings.

3.7 FINISHING GYPSUM BOARD

- A. General: Treat gypsum board joints, interior angles, edge trim, control joints, penetrations, fastener heads, surface defects, and elsewhere as required to prepare gypsum board surfaces for decoration. Promptly remove residual joint compound from adjacent surfaces.
- B. Prefill open joints, rounded or beveled edges, and damaged surface areas.
- C. Apply joint tape over gypsum board joints, except for trim products specifically indicated as not intended to receive tape.
- D. Gypsum Board Finish Levels: Finish panels to levels indicated below, per ASTM C840, for locations indicated:
 1. Leve 0: Where no taping, finishing, or accessories required.
 - a. Use above suspended ceilings and within other concealed spaces that are not fire rated, sound rated, sound or smoke controlled, or does not serves as an air plenum.

2. Level 1: Above suspended ceilings and within other concealed spaces where gypsum board assembly is fire rated, sound rated, sound or smoke controlled, or space serves as an air plenum.
3. Level 2: Provide Level 2 finish at the following conditions:
 - a. Where indicated for tile.
 - b. Utility areas and behind cabinetry.
4. Level 4: Provide Level 4 finish at the following conditions:
 - a. Where indicated as exposed to view and flat finish coat, unless otherwise indicated.
 - b. Where indicated to receive spray texture finish.
5. Level 5: Provide Level 5 finish at the following condition:
 - a. Where indicated for semi-gloss or gloss finish coats.
6. Primer: Refer to Section 099000 –Painting and Coating.

E. Glass-Mat Faced Panels: Finish per manufacturer's written instructions.

3.8 INSTALLATION OF TEXTURE FINISHES

- A. Surface Preparation and Primer: Prepare and apply primer to gypsum panels and other surfaces receiving texture finishes. Apply primer to surfaces that are clean, dry, and smooth.
- B. Texture Finish Application: Mix and apply finish using powered spray equipment, to produce a uniform texture matching approved mockup and free of starved spots or other evidence of thin application or of application patterns.
- C. Prevent texture finishes from coming into contact with surfaces not indicated to receive texture finish by covering them with masking agents, polyethylene film, or other means. If, despite these precautions, texture finishes contact these surfaces, immediately remove droppings and overspray to prevent damage per texture finish manufacturer's written recommendations.

3.9 FIELD QUALITY CONTROL

- A. Above-Ceiling Observation: Before installing gypsum board ceilings, Architect will conduct an above-ceiling observation and report deficiencies in Work observed. Do not proceed with installation of gypsum board to ceiling support framing until deficiencies have been corrected.
 1. Notify Architect 7 days in advance of date and time when Project, or part of Project, will be ready for above-ceiling observation.
- B. Installation of ceiling support framing.

3.10 PROTECTION

- A. Protect adjacent surfaces from drywall compound and promptly remove from floors and other non-drywall surfaces. Repair surfaces stained, marred, or otherwise damaged during drywall application.
- B. Protect installed products from damage from weather, condensation, direct sunlight, construction, and other causes during remainder of construction period.
- C. Remove and replace panels that are wet, moisture damaged, and mold damaged.
 1. Indications that panels are wet or moisture damaged include discoloration, sagging, or irregular shape.
 2. Indications that panels are mold damaged include fuzzy or splotchy surface contamination and discoloration.

3.11 IDENTIFICATION OF FIRE AND SMOKE PARTITION

- A. General: Provide permanently applied lettering on partitions, either labels or paint with stencils, above suspended ceilings, to identify locations of fire and smoke walls.
1. Lettering Size: Minimum of 1 inch high and 10 feet on center.
 2. Lettering Identification: On appropriate partitions, provide the following lettering as identified on Code Analysis Drawings:
 - a. SMOKE BARRIER – 1 HOUR FIRE RATING
 - b. FIRE SEPARATION & SMOKE BARRIER – 2 HOUR FIRE RATING
 - c. FIRE WALL – 2 HOUR FIRE RATING
 - d. FIRE WALL – 1 HOUR FIRE RATING

END OF SECTION 092900

SECTION 093013
CERAMIC TILING

PART 1 - GENERAL

1.1 SUMMARY

- A. Section Includes:
 - 1. Tile for floors and walls.
 - 2. Waterproof and crack isolation membrane.
 - 3. Uncoupling membrane.
 - 4. Setting and grouting materials.
 - 5. Thresholds.
 - 6. Transition strips.
 - 7. Tile access panel system.
- B. Related Requirements:
 - 1. Section 134816 – Manufactured Sound Control Components, for sound control underlayment.

1.2 ADMINISTRATIVE REQUIREMENTS

- A. Preinstallation Meetings: Conduct meeting at Project site.
 - 1. Review requirements in ANSI A108.01 for substrates and for preparation by other trades.

1.3 ACTION SUBMITTALS

- A. Product Data: For each type of product.
- B. Sustainable Design Submittals:
 - 1. Product Data: For adhesives, indicating VOC content.
 - 2. Laboratory Test Reports: For adhesives, indicating compliance with requirements for low-emitting materials.
 - 3. Laboratory Test Reports: For sealers, indicating compliance with requirements for low-emitting materials.
- C. Samples for Verification:
 - 1. Full-size units of each type and composition of tile and for each color and finish required.
 - 2. Full-size units of each type of trim and accessory for each color and finish required.
 - 3. Metal edge strips in 6 inch lengths.

1.4 INFORMATIONAL SUBMITTALS

- A. Qualification Data: For Installer.
- B. Product Certificates: For each type of product, signed by product manufacturer.
- C. Product Test Reports: For each tile-setting, grouting, and certified tile product.

1.5 MAINTENANCE MATERIAL SUBMITTALS

- A. Furnish extra materials that match and are from same production runs as products installed and that are packaged with protective covering for storage and identified with labels describing contents.
 - 1. Tile and Trim Units: Furnish quantity of full-size units equal to 3 percent of amount installed for each type, composition, color, pattern, and size indicated, but not less than 1 full carton of each type of unit.

2. Grout: Furnish quantity of grout equal to 3 percent of amount installed for each type, composition, and color indicated, but not less than 1 package.
3. Floor Sealer: Minimum of 1 gallon in manufacturer's unopened, labeled container. Include instructions for use.
4. Cleaning Agent: Minimum of 5 gallons in unopened container, clearly labeled with manufacturer's logo and instructions for use.

1.6 QUALITY ASSURANCE

- A. Installer Qualifications: Company specializing in performing tile installations and finishing comparable in scope of this Project, with minimum 3 years of documented experience.
 1. Installer employs at least one installer for Project that has completed the Advanced Certification for Tile Installers (ACT) certification for installation of mud floors, membranes, shower receptors, and large format tile.
- B. Mockups: Build mockups to verify selections made under Sample submittals and to demonstrate aesthetic effects and set quality standards for materials and execution.
 1. Build mockup of each type of floor and wall tile installation in size and locations as directed by Architect.
 2. Subject to compliance with requirements, approved mockups may become part of completed Work if undisturbed at time of Substantial Completion.

1.7 DELIVERY, STORAGE, AND HANDLING

- A. Deliver and store packaged materials in original containers with seals unbroken and labels intact until time of use. Comply with requirements in ANSI A137.1 for labeling tile packages.
- B. Store tile and cementitious materials on elevated platforms, under cover, and in a dry location.
- C. Store aggregates where grading and other required characteristics can be maintained and contamination can be avoided.
- D. Store liquid materials in unopened containers and protected from freezing.

1.8 FIELD CONDITIONS

- A. Environmental Limitations: Do not install tile until construction in spaces is complete and ambient temperature and humidity conditions are maintained at levels indicated in referenced standards and manufacturer's written instructions.

PART 2 - PRODUCTS

2.1 MANUFACTURERS

- A. Source Limitations for Tile: Obtain tile of each type and color or finish from one source or producer.
 1. Obtain tile of each type and color or finish from same production run and of consistent quality in appearance and physical properties for each contiguous area.
- B. Source Limitations for Setting and Grouting Materials: Obtain ingredients of a uniform quality for each mortar, adhesive, and grout component from one manufacturer and each aggregate from one source or producer.
 1. Obtain setting and grouting materials, except for unmodified Portland cement and aggregate, from single manufacturer.
 2. Obtain waterproof and crack isolation membranes, except for sheet products, from manufacturer of setting and grouting materials.

- C. Source Limitations for Other Products: Obtain each of the following products specified in this Section from a single manufacturer for each product:
 - 1. Thresholds.
 - 2. Waterproof and crack isolation membrane.
 - 3. Cementitious backer units.
 - 4. Transition edge strips.

2.2 PRODUCTS, GENERAL

- A. ANSI Ceramic Tile Standard: Provide tile that complies with ANSI A137.1 for types, compositions, and other characteristics indicated.
 - 1. Provide tile complying with Standard grade requirements unless otherwise indicated.
- B. ANSI Standards for Tile Installation Materials: Provide materials complying with ANSI A108.02, ANSI standards referenced in other Part 2 articles, ANSI standards referenced by TCNA installation methods specified in tile installation schedules, and other requirements specified.
- C. Factory Blending: For tile exhibiting color variations within ranges, blend tile in factory and package so tile units taken from one package show same range in colors as those taken from other packages and match approved Samples.

2.3 TILE PRODUCTS

- A. Products: See Interior Finish Schedule on Drawings for selected tile products.

2.4 THRESHOLDS

- A. General: Fabricate to sizes and profiles indicated or required to provide transition between adjacent floor finishes.
 - 1. Bevel edges at 1:2 slope, with lower edge of bevel aligned with or up to 1/16 inch above adjacent floor surface. Finish bevel to match top surface of threshold. Limit height of threshold to 1/2 inch or less above adjacent floor surface.
- B. Marble Thresholds: ASTM C503, with a minimum abrasion resistance of 10 according to ASTM C1353 or ASTM C241 and with honed finish.
 - 1. Description: Uniform, fine- to medium-grained, white stone with gray veining.
 - 2. Locations: Where indicated.

2.5 TILE BACKING PANELS

- A. Tile Backer Units: Specified in Section 092900 – Gypsum Board.

2.6 WATERPROOF AND CRACK ISOLATION MEMBRANES

- A. Manufacturer's standard products that comply with ANSI A118.10 and ANSI A118.12; and are recommended by manufacturer for applications indicated.
 - 1. Provide reinforcement and accessories recommended by manufacturer.
- B. Corrugated, high-density polyethylene membrane with a grid structure of square, bone, or other shaped cavities, each cut back in a dovetail configuration, and a polypropylene anchoring fleece laminated to its underside.
 - 1. Products: Subject to compliance with requirements, provide the following:
 - a. ARDEX Americas: Ardex UI 740 Flexbone.
 - b. Custom Building Products: RedGard Uncoupling Mat.
 - c. Laticrete International, Inc.: Laticrete Strata_Mat.
 - d. Schluter Systems L.P.: DITRA.
 - e. Approved substitution.

2. Nominal Thickness: Nominal 0.125 inch.
 3. Description: Allows for separation between membrane and mortar adhering tile to membrane when subjected to excessive substrate movement.
 4. Application: Installation of large format tile where waterproofing membrane is indicated.
- C. Polyethylene Sheet: Nonplasticized polyethylene membrane faced on both sides with nonwoven polyester fabric.
- D. Fabric-Reinforced, Fluid-Applied Membrane: System consisting of liquid-latex rubber or elastomeric polymer and continuous fabric reinforcement that complies with ANSI A118.10 as waterproof membrane, and ANSI A118.12 as crack isolation membrane, and IAPMO approved as a shower receptor.
1. Products: Subject to compliance with requirements, provide one of the following:
 - a. ARDEX Americas: Ardex S 1-K with Ardex SK Mesh.
 - b. Custom Building Products: 9240 Waterproofing and Anti-Fracture Membrane.
 - c. Laticrete International, Inc.: 9235 Waterproof Membrane.
 - d. MAPEI Corporation: Mapelastick AquaDefense with MAPEI Fiberglass Mesh.
 - e. Parex USA, Inc.: Merkrete Hydro-Guard 2000 with Merkrete Fabric Type 2.
 2. Crack Resistance: In-plane cracks up to 1/8 inch wide.
- E. Fluid-Applied Membrane: Liquid-latex rubber or elastomeric polymer.
1. Products: Subject to compliance with requirements, provide one of the following:
 - a. ARDEX Americas: Ardex S 1-K.
 - b. Custom Building Products: RedGuard Waterproofing and Crack Prevention Membrane.
 - c. Laticrete International, Inc.: Hydro Ban or Hydro Barrier.
 - d. MAPEI Corporation: Mapelastick AquaDefense.
 - e. Parex USA, Inc.: Merkrete Fracture Guard.
 2. Crack Resistance: In-plane cracks up to 1/8 inch wide.
 3. Thickness: Maximum 0.020 inch.

2.7 SETTING MATERIALS

- A. Modified Dry-Set Mortar for Thin Set and Medium-Bed Applications: ANSI A118.4.
1. Products: Subject to compliance with requirements, provide one of the following:
 - a. ARDEX Americas: Ardex X 5.
 - b. Custom Building Products: ProLite Premium Large Format Tile Mortar.
 - c. Laticrete International, Inc.: 4-XLT or LHT.
 - d. MAPEI Corporation: Ultraflex LFT.
 - e. Parex USA, Inc.: Merkrete 720 Dustless LHT Mortar.
 - f. Approved substitution.
 2. Prepackaged dry-mortar mix containing dry, redispersible, ethylene vinyl acetate additive to which only water must be added at Project site.
 3. Applications:
 - a. Thin Set Type: 3/16 inch thick application for tile with no edge greater than 15 inches.
 - b. Medium Set Type: 1/2 to 5/8 inch thick application for tile with at least 1 edge greater than 15 inches.
 4. For wall applications, provide mortar that complies with requirements for nonsagging mortar in addition to other requirements in ANSI A118.4.
- B. Improved Modified Dry-Set Mortar (Thinset): ANSI A118.15.
1. Products: Subject to compliance with requirements, provide one of the following:
 - a. ARDEX Americas: ARDEX S 28 MICROTEC.
 - b. Custom Building Products: Complete Contact Fortified Mortar.
 - c. Laticrete International, Inc.: 254 Platinum.
 - d. MAPEI Corporation: Ultraflex 3.
 - e. Approved substitution.

2. Prepackaged dry-mortar mix containing dry, redispersible, ethylene vinyl acetate additive to which only water must be added at Project site
3. Application: For wall applications, provide mortar that complies with requirements for nonsagging mortar in addition to other requirements in ANSI A118.15.

2.8 GROUT MATERIALS

- A. Standard Cement Grout: ANSI A118.6.
 1. Products: Subject to compliance with requirements, provide one of the following:
 - a. ARDEX Americas: ARDEX FH Sanded Floor and Wall Grout.
 - b. Laticrete International, Inc.: 1500 Sanded Grout.
 - c. MAPEI Corporation: Keracolor S Sanded Grout.
 - d. Parex USA, Inc.: Merkrete DURACOLOR Sanded Grout.
 - e. Approved substitution.
- B. High-Performance Tile Grout: ANSI A118.7.
 1. Products: Subject to compliance with requirements, provide one of the following:
 - a. ARDEX Americas: ARDEX FL Rapid Set, Flexible, Sanded Grout.
 - b. Laticrete International, Inc.: Permacolor Grout.
 - c. MAPEI Corporation:
 - d. Parex USA, Inc.: Merkrete ProGrout.
 - e. Approved substitution.
 2. Contractor's Option: Contractor may provide either of the following polymer type mortar mixes:
 - a. Ethylene vinyl acetate or acrylic additive, in dry, redispersible form, prepackaged with other dry ingredients.
 - b. Acrylic resin or styrene-butadiene-rubber in liquid-latex form for addition to prepackaged dry-grout mix.
 3. Color: As selected by Architect from manufacturer's full color range.
- C. Provide other materials, not specifically described but required for a complete and proper installation, subject to approval of Architect.

2.9 SOUND CONTROL UNDERLAYMENT

- A. Specified in Section 134816 – Manufactured Sound Control Components.

2.10 MISCELLANEOUS MATERIALS

- A. Trowelable Patching Compounds: Latex-modified, portland cement-based formulation provided or approved by manufacturer of tile-setting materials for installations indicated.
 1. Products: Subject to compliance with requirements, provide one of the following:
 - a. ARDEX Americas: Ardex SD-P Rapid.
 - b. Laticrete International, Inc.: L&M Duracrete.
 - c. MAPEI Corporation: Planipatch.
 - d. Parex USA, Inc.: Merkrete Underlay RS
 - e. Approved substitution.
 2. Compressive Strength: Minimum 3,500 psi at 28 days when tested according to ASTM C109.
 3. Flexural Strength: Minimum 1,000 psi at 28 days when tested according to ASTM C348.
 4. Set Time: No more than 1 hour initial when tested according to ASTM C191.
- B. Metal Transition Strips: Angle or L-shaped transition and edging strips, in height to match adjacent material thicknesses, designed specifically for applications indicated below and on Drawings.
 1. Applications:
 - a. Transition between floor finishes of different heights.
 - b. Expansion and control joints at floors and walls.
 - c. Open edges of floor tile.

- d. Floor to wall joints.
 - e. Open edges of wall tile.
 - f. Wall corners, outside and inside.
 - 2. Lengths: As indicated on Drawings.
- C. Temporary Protective Coating: Product formulated to protect exposed surfaces of tile against adherence of mortar and grout; compatible with tile, mortar, and grout products; and easily removable after grouting is completed without damaging grout or tile.
- 1. Grout release in form of manufacturer's standard proprietary liquid coating that is specially formulated and recommended for use as temporary protective coating for tile.
- D. Tile Cleaner: Neutral cleaner capable of removing soil and residue without harming tile and grout surfaces, specifically approved for materials and installations indicated by tile and grout manufacturers.
- 1. Custom Building Products: Aqua Mix Heavy Duty Tile & Grout Cleaner.
- E. Floor Sealer: Manufacturer's standard product for sealing grout joints that does not change color or appearance of grout.
- 1. Products: Subject to compliance with requirements, provide one of the following:
 - a. Bonsal American; an Oldcastle company: Grout Sealer.
 - b. Custom Building Products: Aqua Mix Grout Sealer.
 - c. Jamo Inc.: TileLab Grout and Tile Sealer.
 - d. SGM, Inc.: SGM Grout Sealer.
 - e. Summitville Tiles, Inc.: SL-15 Invisible Seal.
 - f. Approved substitution.

2.11 MIXING MORTARS AND GROUT

- A. Mix mortars and grouts to comply with referenced standards and mortar and grout manufacturers' written instructions. Add materials, water, and additives in accurate proportions.
- B. Obtain and use type of mixing equipment, mixer speeds, mixing containers, mixing time, and other procedures to produce mortars and grouts of uniform quality with optimum performance characteristics for installations indicated.

PART 3 - EXECUTION

3.1 EXAMINATION

- A. Examine substrates, areas, and conditions where tile will be installed, with Installer present, for compliance with requirements for installation tolerances and other conditions affecting performance of installed tile.
 - 1. Verify that substrates for setting tile are firm, dry, clean, free of coatings that are incompatible with tile-setting materials including curing compounds and other substances that contain soap, wax, oil, or silicone; and comply with flatness tolerances required by ANSI A108.01 for installations indicated.
 - 2. Verify that concrete substrates for tile floors installed with thin-set mortar comply with surface finish requirements in ANSI A108.01 for installations indicated.
 - a. Verify that surfaces that received a steel trowel finish have been mechanically scarified.
 - b. Verify that protrusions, bumps, and ridges have been removed by sanding or grinding.
 - 3. Verify that installation of grounds, anchors, recessed frames, electrical and mechanical units of Work, and similar items located in or behind tile has been completed.
 - 4. Verify that joints and cracks in tile substrates are coordinated with tile joint locations. If not coordinated, adjust joint locations in consultation with Architect.

3.2 PREPARATION

- A. Protect surrounding Work from damage or disfiguration. Vacuum clean existing surfaces and damp clean. Seal substrate surface cracks with filler. Level existing surfaces to acceptable flatness tolerances.
- B. Remove coatings, including curing compounds and other substances that contain soap, wax, oil, or silicone, that are incompatible with tile-setting materials.
- C. Fill cracks, holes, and depressions in concrete substrates for tile floors installed with thin-set mortar with trowelable leveling and patching compound specifically recommended by tile-setting material manufacturer.
- D. Where indicated, prepare substrates to receive waterproofing by applying a reinforced mortar bed that complies with ANSI A108.1A and is sloped 1/4 inch per foot toward drains.
- E. Blending: For tile exhibiting color variations, verify that tile has been factory blended and packaged so tile units taken from one package show same range of colors as those taken from other packages and match approved Samples. If not factory blended, either return to manufacturer or blend tiles at Project site before installing.
- F. Field-Applied Temporary Protective Coating: If indicated under tile type or needed to prevent grout from staining or adhering to exposed tile surfaces, precoat them with continuous film of temporary protective coating, taking care not to coat unexposed tile surfaces.
- G. Sound Control Underlayment: Comply with installation requirements in Section 134816 – Manufactured Sound Control Components.

3.3 INSTALLATION OF TILE BACKING PANEL

- A. Install cementitious backer units and treat joints per ANSI A108.11, manufacturer's written instructions, and in compliance with Section 092900.

3.4 INSTALLATION OF WATERPROOFING AND CRACK ISOLATION MEMBRANE

- A. Install waterproofing and crack isolation membrane to comply with ANSI A108.13 and manufacturer's written instructions to produce waterproof membrane of uniform thickness and bonded securely to substrate.
- B. Install crack isolation membrane to comply with ANSI A108.17 and manufacturer's written instructions to produce membrane of uniform thickness and bonded securely to substrate.
- C. Do not install tile or setting materials over membrane until membrane has cured.

3.5 INSTALLATION OF TILE

- A. Comply with TCNA's "Handbook for Ceramic Tile Installation" for TCNA installation methods specified in tile installation schedules. Comply with parts of ANSI A108 Series "Specifications for Installation of Ceramic Tile" that are referenced in TCNA installation methods, specified in tile installation schedules, and apply to types of setting and grouting materials used.
 - 1. For the following installations, follow procedures in ANSI A108 Series of tile installation standards for providing 95 percent mortar coverage:
 - a. Tile floors in wet areas.
 - b. Tile floors composed of tiles 8 by 8 inches or larger.
 - c. Tile floors composed of rib-backed tiles.

- B. Extend tile Work into recesses and under or behind equipment and fixtures to form complete covering without interruptions unless otherwise indicated. Terminate Work neatly at obstructions, edges, and corners without disrupting pattern or joint alignments.
- C. Accurately form intersections and returns. Perform cutting and drilling of tile without marring visible surfaces. Carefully grind cut edges of tile abutting trim, finish, or built-in items for straight aligned joints. Fit tile closely to electrical outlets, piping, fixtures, and other penetrations so plates, collars, or covers overlap tile.
- D. Provide manufacturer's standard trim shapes where necessary to eliminate exposed tile edges.
- E. Jointing Pattern: Lay tile in grid pattern unless otherwise indicated. Lay out tile Work and center tile fields in both directions in each space or on each wall area. Lay out tile Work to minimize use of pieces that are less than 1/2 of a tile. Provide uniform joint widths unless otherwise indicated.
- F. Joint Widths: Unless otherwise indicated, install tile with the following joint widths:
 - 1. Porcelain Tile: 1/8 inch.
 - 2. Glazed Wall Tile: 1/16 inch.
- G. Lay out tile wainscots to dimensions indicated or to next full tile beyond dimensions indicated.
- H. Expansion Joints: Provide expansion joints and other sealant-filled joints, including control, contraction, and isolation joints, where indicated. Form joints during installation of setting materials, mortar beds, and tile. Do not saw-cut joints after installing tiles. Comply with requirements of TCNA, EJ171.
 - 1. Where joints occur in concrete substrates, locate joints in tile surfaces directly above them.
 - 2. Prepare joints and apply sealants to comply with requirements in Section 079200 – Joint Sealers.
- I. Transition Strips: Install at locations indicated, where exposed edge of tile flooring meets carpet or other flooring that finishes flush with top of tile, and where exposed edge of tile flooring meets carpet or other flooring that finishes flush with or below top of tile.

3.6 CLEANING

- A. Cleaning: On completion of placement and grouting, clean ceramic tile surfaces so they are free of foreign matter.
 - 1. Remove latex-portland cement grout residue from tile as soon as possible.
 - 2. Clean grout smears and haze from tile per tile and grout manufacturer's written instructions but no sooner than 10 days after installation. Use only cleaners recommended by tile and grout manufacturers and only after determining that cleaners are safe to use by testing on samples of tile and other surfaces to be cleaned. Protect metal surfaces and plumbing fixtures from effects of cleaning. Flush surfaces with clean water before and after cleaning.
 - 3. Remove temporary protective coating by method recommended by coating manufacturer and that is acceptable to tile and grout manufacturer. Trap and remove coating to prevent drain clogging.

3.7 PROTECTION

- A. Prohibit foot and wheel traffic from tiled floors for at least 7 days after grouting is completed. Protect installed tile Work with kraft paper or other heavy covering during construction period to prevent staining, damage, and wear. If recommended by tile manufacturer, apply coat of neutral protective cleaner to completed tile walls and floors.
 - 1. Before final inspection, remove protective coverings and rinse neutral protective cleaner from tile surfaces.

END OF SECTION 093013

SECTION 096513
RESILIENT BASE AND ACCESSORIES

PART 1 - GENERAL

1.1 SUMMARY

- A. Section Includes:
1. Thermoset-rubber base.

1.2 ACTION SUBMITTALS

- A. Product Data: For each type of product.
- B. Sustainable Design Submittals:
1. Product Data: For adhesives, indicating VOC content.
 2. Laboratory Test Reports: For adhesives, indicating compliance with requirements for low-emitting materials.
 3. Product Data: For sealants, indicating VOC content.
 4. Laboratory Test Reports: For sealants, indicating compliance with requirements for low-emitting materials.
 5. Laboratory Test Reports: For resilient base [**and stair**] products and accessories, indicating compliance with requirements for low-emitting materials.
 6. Environmental Product Declaration (EPD): For each product.
 7. Health Product Declaration (HPD): For each product.
 8. Sourcing of Raw Materials: Corporate sustainability report for each manufacturer.
- C. Samples for Verification: For each type of product indicated and for each color, texture, and pattern required in manufacturer's standard-size Samples, but not less than 6 inches long.
- D. Product Schedule: For resilient base and accessory products. Use same designations indicated on Drawings.

1.3 MAINTENANCE MATERIAL SUBMITTALS

- A. Furnish extra materials, from the same product run, that match products installed and that are packaged with protective covering for storage and identified with labels describing contents.
1. Furnish not less than 10 linear feet for every 500 linear feet or fraction thereof, of each type, color, pattern, and size of resilient product installed.

1.4 DELIVERY, STORAGE, AND HANDLING

- A. Store resilient products and installation materials in dry spaces protected from the weather, with ambient temperatures maintained within range recommended by manufacturer, but not less than 50 deg F or more than 90 deg F.

1.5 FIELD CONDITIONS

- A. Ambient Conditions:
1. Maintain ambient temperatures within range recommended by manufacturer, but not less than 70 deg F or more than 95 deg F, in spaces to receive resilient products during the following time periods:
 - a. 48 hours before installation.
 - b. During installation.
 - c. 48 hours after installation.

2. Until Substantial Completion, maintain ambient temperatures within range recommended by manufacturer, but not less than 55 deg F or more than 95 deg F.
3. Install resilient products after other finishing operations, including painting, have been completed.

PART 2 - PRODUCTS

2.1 PERFORMANCE CRITERIA

- A. Products shall comply with requirements of the California Department of Public Health's "Standard Method for the Testing and Evaluation of Volatile Organic Chemical Emissions from Indoor Sources Using Environmental Chambers."

2.2 THERMOSET-RUBBER BASE

- A. Products: See Interior Finish Schedule on Drawings for selected resilient base products.
 1. Acceptable Manufacturers:
 - a. Armstrong World Industries, Inc.
 - b. Burke Mercer Flooring Products; Division of Burke Industries, Inc.
 - c. Flexco, Inc.
 - d. Johnsonite; A Tarkett Company.
 - e. Roppe Corporation, USA.
 - f. Approved substitution.
- B. Product Standard: ASTM F1861, Type TS (rubber, vulcanized thermoset), Group I (solid, homogeneous).
 1. Style and Location:
 - a. Style A, Straight: Provide in areas with carpet.
 - b. Style B, Cove: Provide in areas with resilient or other hard surface flooring unless indicated otherwise.
 2. Thickness: 0.125 inch minimum.
 3. Height: As indicated on Drawings.
 4. Lengths: Coils in manufacturer's standard length.
 5. Inside and Outside Corners: Job formed.
 6. Finish: Satin.
 7. Colors and Patterns: As indicated in Interior Finish Schedule on Drawings.

2.3 RUBBER MOLDING ACCESSORY

- A. Products:
 1. See Interior Finish Legend on Drawings for selected resilient base products.
 2. Provide molding products by same manufacturer as resilient base.

2.4 INSTALLATION MATERIALS

- A. Trowelable Leveling and Patching Compounds: Latex-modified, portland-cement-based or blended hydraulic-cement-based formulation provided or approved by resilient-product manufacturer for applications indicated.
- B. Adhesives: Water-resistant type recommended by resilient-product manufacturer for resilient products and substrate conditions indicated.
 1. Adhesives shall have a VOC content of 50 g/L or less and 60 g/L or less for rubber stair treads.
- C. Stair-Tread Nose Filler: 2-part epoxy compound recommended by resilient stair-tread manufacturer to fill nosing substrates that do not conform to tread contours.

- D. Metal Edge Strips: Extruded aluminum with mill finish, nominal 2 inches wide, of height required to protect exposed edges of flooring, and in maximum available lengths to minimize running joints.

PART 3 - EXECUTION

3.1 EXAMINATION

- A. Examine substrates, with Installer present, for compliance with requirements for maximum moisture content and other conditions affecting performance of Work.
 - 1. Verify that finishes of substrates comply with tolerances and other requirements specified in other Sections and that substrates are free of cracks, ridges, depressions, scale, and foreign deposits that might interfere with adhesion of resilient products.
- B. Proceed with installation only after unsatisfactory conditions have been corrected.
 - 1. Installation of resilient products indicates acceptance of surfaces and conditions.

3.2 PREPARATION

- A. Prepare substrates according to manufacturer's written instructions to ensure adhesion of resilient products.
- B. Concrete Substrates for Resilient Stair Accessories: Prepare horizontal surfaces according to ASTM F710.
 - 1. Verify that substrates are dry and free of curing compounds, sealers, and hardeners.
 - 2. Remove substrate coatings and other substances that are incompatible with adhesives and that contain soap, wax, oil, or silicone, using mechanical methods recommended by manufacturer. Do not use solvents.
 - 3. Alkalinity and Adhesion Testing: Perform tests recommended by manufacturer. Proceed with installation only after substrate alkalinity falls within range on pH scale recommended by manufacturer in writing, but not less than 5 or more than 9 pH.
 - 4. Moisture Testing: Perform tests so that each test area does not exceed 1,000 sq. ft., and perform no fewer than 3 tests in each installation area and with test areas evenly spaced in installation areas.
 - a. Anhydrous Calcium Chloride Test: ASTM F1869. Proceed with installation only after substrates have maximum moisture-vapor-emission rate of 3 lb of water/1,000 sq. ft. in 24 hours.
 - b. Relative Humidity Test: Using in-situ probes, ASTM F2170. Proceed with installation only after substrates have a maximum 75 percent relative humidity level measurement.
- C. Fill cracks, holes, and depressions in substrates with trowelable leveling and patching compound; remove bumps and ridges to produce a uniform and smooth substrate.
- D. Do not install resilient products until materials are the same temperature as space where they are to be installed.
 - 1. At least 48 hours in advance of installation, move resilient products and installation materials into spaces where they will be installed.
- E. Immediately before installation, sweep and vacuum clean substrates to be covered by resilient products.

3.3 INSTALLATION OF RESILIENT BASE

- A. Comply with manufacturer's written instructions for installing resilient base.
- B. Apply resilient base to walls, columns, pilasters, casework and cabinets in toe spaces, and other permanent fixtures in rooms and areas where base is required.

- C. Install resilient base in lengths as long as practical without gaps at seams and with tops of adjacent pieces aligned.
- D. Tightly adhere resilient base to substrate throughout length of each piece, with base in continuous contact with horizontal and vertical substrates.
- E. Do not stretch resilient base during installation.
- F. On masonry surfaces or other similar irregular substrates, fill voids along top edge of resilient base with manufacturer's recommended adhesive filler material.
- G. Preformed Corners: Install preformed corners before installing straight pieces.
- H. Job-Formed Corners:
 - 1. Outside Corners: Use straight pieces of maximum lengths possible and form with returns not less than 3 inches in length.
 - a. Form without producing discoloration (whitening) at bends.
 - 2. Inside Corners: Use straight pieces of maximum lengths possible and form with returns not less than 3 inches in length.
 - a. Miter or cope corners to minimize open joints.

3.4 INSTALLATION OF RESILIENT ACCESSORIES

- A. Comply with manufacturer's written instructions for installing resilient accessories.
- B. Resilient Stair Accessories:
 - 1. Use stair-tread-nose filler to fill nosing substrates that do not conform to tread contours.
 - 2. Tightly adhere to substrates throughout length of each piece.
 - 3. For treads installed as separate, equal-length units, install to produce a flush joint between units.
- C. Resilient Molding Accessories: Butt to adjacent materials and tightly adhere to substrates throughout length of each piece. Install reducer strips at edges of floor covering that would otherwise be exposed.

3.5 CLEANING

- A. Comply with manufacturer's written instructions for cleaning and protecting resilient products.
- B. Perform the following operations immediately after completing resilient-product installation:
 - 1. Remove adhesive and other blemishes from surfaces.
 - 2. Sweep and vacuum horizontal surfaces thoroughly.
 - 3. Damp-mop horizontal surfaces to remove marks and soil.

3.6 PROTECTION

- A. Protect resilient products from mars, marks, indentations, and other damage from construction operations and placement of equipment and fixtures during remainder of construction period.
- B. Cover resilient products subject to wear and foot traffic until Substantial Completion.

END OF SECTION 096513

SECTION 096519
RESILIENT TILE FLOORING

PART 1 - GENERAL

1.1 SUMMARY

- A. Section Includes:
 - 1. Luxury vinyl floor tile.

1.2 ACTION SUBMITTALS

- A. Product Data: For each type of product indicated.
- B. Samples for Verification: Full-size units of each color and pattern of floor tile required.
- C. Product Schedule: For resilient sheet flooring. Use same designations indicated on Drawings

1.3 INFORMATIONAL SUBMITTALS

- A. Qualification Data: For qualified installer.
- B. Product Test Reports: Based on evaluation of comprehensive tests performed by a qualified testing agency, for floor coverings.
- C. Moisture and alkali test results.
- D. Slip-Resistance Certification: Manufacturer's certificate indicating that products meet or exceed specified requirements.

1.4 CLOSEOUT SUBMITTALS

- A. Maintenance Data: For each type of floor tile to include in maintenance manuals.

1.5 MAINTENANCE MATERIALS SUBMITTALS

- A. Furnish extra materials, from same product run, that match products installed and that are packaged with protective covering for storage and identified with labels describing contents.
 - 1. Floor Tile: Furnish 2 boxes for every 50 boxes or fraction thereof, of each type, color, and pattern of floor tile installed.

1.6 QUALITY ASSURANCE

- A. Installer Qualifications: An entity that employs installers and supervisors who are competent in techniques required by manufacturer for floor covering installation indicated.
 - 1. Engage an installer who employs workers for this Project who are trained or certified by manufacturer for installation techniques required.

1.7 DELIVERY, STORAGE, AND HANDLING

- A. Store floor tile and installation materials in dry spaces protected from the weather, with ambient temperatures maintained within range recommended by manufacturer, but not less than 50 deg F or more than 90 deg F. Store floor tiles on flat surfaces.

1.8 FIELD CONDITIONS

- A. Maintain ambient temperatures within range recommended by manufacturer, but not less than 70 deg F or more than 95 deg F, in spaces to receive floor tile during the following time periods:
 - 1. 48 hours before installation.
 - 2. During installation.
 - 3. 48 hours after installation.
- B. After installation and until Substantial Completion, maintain ambient temperatures within range recommended by manufacturer, but not less than 55 deg F or more than 95 deg F.
- C. Close spaces to traffic during and for a minimum of for 48 hours after floor tile installation.
- D. Install floor tile after other finishing operations, including painting, have been completed.

PART 2 - PRODUCTS

2.1 RESILIENT TILE FLOORING

- A. Products: See Interior Finish Schedules on Drawings for selected resilient flooring products.
 - 1. Acceptable Manufacturers:
 - a. Armstrong World Industries, Inc.
 - b. Congoleum Corporation.
 - c. Forbo Flooring Systems.
 - d. Gerflor.
 - e. Johnsonite; a Tarkett Company.
 - f. Mannington Mills, Inc.
 - g. Approved substitution.

2.2 SOLID LUXURY VINYL FLOOR TILE (LVT)

- A. Products: Subject to compliance with requirements, provide products from 1 of the following:
 - 1. Amtico International Inc.
 - 2. Karndean, USA.
- B. Performance Criteria:
 - 1. Flexibility: 1 inch mandrel, no crack or break; Pass per ASTM F137.
 - 2. Total Thickness: 0.100 inch, plus or minus 0.005 inch, per ASTM F386.
 - 3. Chemical Resistance: Excellent resistance per ASTM F925.
 - 4. Tile Size: Plus or minus 0.016 inch per lineal foot; per ASTM F536.
 - 5. Tile Squareness: Maximum 0.010 inch; per ASTM F540.
 - 6. Dimensional Stability: Maximum 0.020 inch per lineal foot; per Fed. Std. No. 501a Method 6211.
 - 7. Static Load Limit/Long-Term Indentation Armstrong Modified 1,000 psi: Pass, according to ASTM F970.
 - 8. Abrasion Resistance:
 - a. Taber Test (H22 wheels, 1 kg load, 1,000 cycles): 0.14 g.
 - b. Thickness Loss (EN 660 Group T): 0.077 mm.
- C. Tile Standard: ASTM F1700.
 - 1. Class: Class III, printed film vinyl tile.
 - 2. Type: Type A, smooth surface and Type B, embossed surface.
- D. Thickness: 0.100 inch.
- E. Size: 3 by 36 inches and as indicated.

- F. Colors and Patterns: As indicated on Interior Finish Schedule on Drawings.
- G. Floor Patterns: Multiple colors and tile sizes, including accent striping layout insets.

2.3 INSTALLATION MATERIALS

- A. Trowelable Leveling and Patching Compounds: Latex-modified, portland cement based or blended hydraulic-cement-based formulation provided or approved by manufacturer for applications indicated.
- B. Adhesives: Water-resistant type recommended or furnished by flooring manufacturer to suit floor tile and substrate conditions indicated.
- C. Sealers and Finish Coats: Premium-type products as recommended or furnished by flooring manufacturer for resilient floor tile.

PART 3 - EXECUTION

3.1 EXAMINATION

- A. Verify that finishes of substrates comply with tolerances and other requirements specified in other Sections and that substrates are free of cracks, ridges, depressions, scale, and foreign deposits that might interfere with adhesion of floor tile.

3.2 PREPARATION

- A. Concrete Substrates: Prepare per ASTM F710.
 - 1. Verify that concrete is smooth and flat and complies with flatness F(F); and of levelness F(L) tolerances specified in Section 033000.
 - 2. Verify that substrates are dry and free of curing compounds, sealers, and hardeners.
 - 3. Remove substrate coatings and other substances that are incompatible with adhesives and that contain soap, wax, oil, or silicone, using mechanical methods recommended by manufacturer. Do not use solvents.
 - 4. Moisture Testing: Perform tests recommended by manufacturer.
 - 5. Verify that concrete has cured to maximum moisture content, relative humidity, and pH as recommended by manufacturer to ensure proper bonding with adhesive.
- B. Fill cracks, holes, and depressions in substrates with trowelable leveling and patching compound and remove bumps and ridges to produce a uniform and smooth substrate.
- C. Do not install floor tiles until they are same temperature as space where they are to be installed.
 - 1. Move resilient products and installation materials into spaces where they will be installed at least 48 hours in advance of installation.
- D. Sweep and vacuum clean substrates to be covered by resilient products immediately before installation.

3.3 INSTALLATION OF FLOOR TILE

- A. Comply with manufacturer's written instructions for installing floor tile.
- B. Lay out floor tiles from center marks established with principal walls, discounting minor offsets, so tiles at opposite edges of room are of equal width. Adjust as necessary to avoid using cut widths that equal less than one-half tile at perimeter.
 - 1. Lay tiles square with room axis unless indicated otherwise.

- C. Match floor tiles for color and pattern by selecting tiles from cartons in the same sequence as manufactured and packaged, if so numbered. Discard broken, cracked, chipped, or deformed tiles.
 - 1. Lay tiles with grain running in one direction unless indicated otherwise.
- D. Scribe, cut, and fit floor tiles to butt neatly and tightly to vertical surfaces and permanent fixtures including built-in furniture, cabinets, pipes, outlets, and door frames.
- E. Extend floor tiles into toe spaces, door reveals, closets, and similar openings. Extend floor tiles to center of door openings.
- F. Maintain reference markers, holes, and openings that are in place or marked for future cutting by repeating on floor tiles as marked on substrates. Use chalk or other nonpermanent, nonstaining marking device.
- G. Install floor tiles on covers for telephone and electrical boxes, building expansion-joint covers, and similar items in installation areas. Maintain overall continuity of color and pattern between pieces of tile installed on covers and adjoining tiles. Tightly adhere tile edges to substrates that abut covers and to cover perimeters.
- H. Adhere floor tiles to flooring substrates using a full spread of adhesive applied to substrate to produce a completed installation without open cracks, voids, raising and puckering at joints, telegraphing of adhesive spreader marks, and other surface imperfections.

3.4 CLEANING

- A. Comply with manufacturer's written instructions for cleaning and protection of floor tile.
- B. Perform the following operations immediately after completing floor tile installation:
 - 1. Remove adhesive and other blemishes from exposed surfaces.
 - 2. Sweep and vacuum surfaces thoroughly.
 - 3. Damp-mop surfaces to remove marks and soil.

3.5 PROTECTION

- A. Protect floor tile products from mars, marks, indentations, and other damage from construction operations and placement of equipment and fixtures during remainder of construction period.
- B. Sealers and Finish Coats: Remove soil, visible adhesive, and surface blemishes from resilient floor tile surfaces before applying liquid cleaners, sealers, and finish products.
 - 1. Apply number of coats as recommended by flooring product manufacturer.
- C. Cover floor tile until Substantial Completion.

END OF SECTION 096519

SECTION 096813

TILE CARPETING

PART 1 - GENERAL

1.1 SUMMARY

- A. Section Includes:
 - 1. Modular carpet tile.
- B. Related Requirements:
 - 1. Section 134816 – Manufactured Sound Control Components, for sound and impact noise control mats.

1.2 ADMINISTRATIVE REQUIREMENTS

- A. Preinstallation Meeting: Conduct meeting at Project site.
 - 1. Review methods and procedures related to carpet tile installation including the following:
 - a. Review delivery, storage, and handling procedures.
 - b. Review ambient conditions and ventilation procedures.
 - c. Review subfloor preparation procedures.

1.3 REFERENCE

- A. HUD USE OF MATERIALS BULLETIN UM44d Regarding Carpet

1.4 ACTION SUBMITTALS

- A. Product Data: For each type of product.
 - 1. Include manufacturer's written data on physical characteristics, durability, and fade resistance.
 - 2. Include manufacturer's written installation recommendations for each type of substrate.
- B. Sustainable Design Submittals:
 - 1. Product Data: For adhesives, indicating VOC content.
 - 2. Laboratory Test Reports: For adhesives, indicating compliance with requirements for low-emitting materials.
 - 3. Laboratory Test Reports: For flooring products, indicating compliance with requirements for low-emitting materials.
- C. Shop Drawings: For carpet tile installation, plans showing the following:
 - 1. Columns, doorways, enclosing walls or partitions, built-in cabinets, and locations where cutouts are required in carpet tiles.
 - 2. Carpet tile type, color, and dye lot.
 - 3. Type of subfloor.
 - 4. Type of installation.
 - 5. Pattern of installation.
 - 6. Pattern type, location, and direction.
 - 7. Pile direction.
 - 8. Type, color, and location of insets and borders.
 - 9. Type, color, and location of edge, transition, and other accessory strips.
 - 10. Transition details to other flooring materials.

- D. Samples for Verification: For each of the following products and for each color and texture required. Label each Sample with manufacturer's name, material description, color, pattern, and designation indicated on Drawings and in schedules.
 - 1. Carpet Tile: Full-size Sample.
 - 2. Exposed Edge, Transition, and Other Accessory Stripping: 12 inch long Samples.
 - E. Product Schedule: For carpet tile. Use same designations indicated on Drawings.
 - F. Sustainable Product Certification: Provide ANSI/NSF 140 certification for carpet products.
- 1.5 INFORMATIONAL SUBMITTALS
- A. Qualification Data: For Installer.
 - B. Product Test Reports: For carpet tile, for tests performed by a qualified testing agency.
 - C. Sample Warranty: For special warranty.
- 1.6 CLOSEOUT SUBMITTALS
- A. Maintenance Data: For carpet tiles to include in maintenance manuals. Include the following:
 - 1. Methods for maintaining carpet tile, including cleaning and stain-removal products and procedures and manufacturer's recommended maintenance schedule.
 - 2. Precautions for cleaning materials and methods that could be detrimental to carpet tile.
- 1.7 MAINTENANCE MATERIAL SUBMITTALS
- A. Furnish extra materials, from same product run, that match products installed and that are packaged with protective covering for storage and identified with labels describing contents.
 - 1. Carpet Tile: Full-size units equal to 5 percent of amount installed for each type indicated, but not less than 2 complete cartons.
- 1.8 QUALITY ASSURANCE
- A. Installer Qualifications: An experienced installer with a minimum of 3 years of experience, who is certified by the International Certified Floorcovering Installers Association at Commercial II certification level.
- 1.9 DELIVERY, STORAGE, AND HANDLING
- A. Comply with CRI's "CRI Carpet Installation Standard."
- 1.10 FIELD CONDITIONS
- A. Comply with CRI's "CRI Carpet Installation Standard" for temperature, humidity, and ventilation limitations.
 - B. Environmental Limitations: Do not deliver or install carpet tiles until spaces are enclosed and weathertight, wet-Work in spaces is complete and dry, and ambient temperature and humidity conditions are maintained at levels planned for building occupants during remainder of construction period.
 - C. Do not install carpet tiles over concrete slabs until slabs have cured and are sufficiently dry to bond with adhesive and concrete slabs have pH range recommended by carpet tile manufacturer.
 - D. Where items are indicated for installation on top of carpet tiles, install carpet tiles before installing these items.

1.11 WARRANTY

- A. Special Warranty for Carpet Tiles: Manufacturer agrees to repair or replace components of carpet tile installation that fail in materials or workmanship within specified warranty period.
 - 1. Warranty does not include deterioration or failure of carpet tile due to unusual traffic, failure of substrate, vandalism, or abuse.
 - 2. Failures include the following:
 - a. More than 10 percent edge raveling, snags, and runs.
 - b. Dimensional instability.
 - c. Excess static discharge.
 - d. Loss of tuft-bind strength.
 - e. Loss of face fiber.
 - f. Delamination.
 - 3. Warranty Period: 10 years from date of Substantial Completion.

PART 2 - PRODUCTS

2.1 MANUFACTURERS

- A. Manufacturers: Subject to compliance with requirements, provide specified products from one of the following:
 - 1. Atlas Carpet Mills, Inc.
 - 2. Bentley Prince Street, Inc.
 - 3. InterfaceFLOR, LLC.
 - 4. Mannington Mills, Inc.
 - 5. Milliken & Company.
 - 6. Mohawk Group (The); Mohawk Carpet, LLC.
 - 7. Patcraft; a division of Shaw Industries, Inc.
 - 8. Shaw Contract Group; a Berkshire Hathaway company.
 - 9. Tandus Centiva.

2.2 CPT-X

- A. Products: As indicated in Interior Finish Legend on Drawings.

2.3 SOUND AND IMPACT NOISE CONTROL MATS

- A. Specified in Section 134816 – Manufactured Sound Control Components.

2.4 ACCESSORIES

- A. Trowelable Leveling and Patching Compounds: Latex-modified, hydraulic-cement-based formulation provided or recommended by carpet tile manufacturer.
- B. Adhesives: Water-resistant, mildew-resistant, nonstaining, pressure-sensitive type to suit products and subfloor conditions indicated, that comply with flammability requirements for installed carpet tile, and are recommended by carpet tile manufacturer for releasable installation.
 - 1. Adhesives shall have a VOC content of 50 g/L or less.
 - 2. Adhesive shall comply with testing and product requirements of California Department of Public Health's "Standard Method for the Testing and Evaluation of Volatile Organic Chemical Emissions from Indoor Sources Using Environmental Chambers."

- C. Adhesive Tape: Water-resistant type, compatible with flooring, recommended by manufacturer to suit carpet and substrate conditions indicated, and comply with the following moisture resistant properties:
 - 1. Basis-of-Design Product: Subject to compliance with requirements, provide the following:
 - a. InterfaceFLOR, LLC: TacTiles GlasBac.
 - b. Shaw Contract Group; a Berkshire Hathaway company: LokDots.
 - c. Approved substitution.
 - 2. Composition: Compounded acrylic adhesive, applied to PET polyester backing with PET polyester release liner.
 - 3. Solids: Greater than 99 percent.
 - 4. Size: 3 inch by 3 inch.
 - 5. Suitable for use over new concrete substrates with in-situ moisture measurements of up to 80 percent RH as measured by ASTM F2170 or moisture vapor emission rate (MVER) of up to 3 pounds per ASTM F1869, and a pH of 10.
- D. Metal Edge/Transition Strips: Extruded aluminum with mill finish of profile and width shown, of height required to protect exposed edge of carpet, and of maximum lengths to minimize running joints.
- E. Resilient Transition Strips: Specified in Section 096513 – Resilient Base and Accessories.

PART 3 - EXECUTION

3.1 EXAMINATION

- A. Examine substrates, areas, and conditions, with Installer present, for compliance with requirements for maximum moisture content, alkalinity range, installation tolerances, and other conditions affecting carpet tile performance.
- B. Examine carpet tile for type, color, pattern, and potential defects.
- C. Concrete Slabs: Verify that finishes comply with requirements specified in Section 033000 – Cast-in-Place Concrete and that surfaces are free of cracks, ridges, depressions, scale, and foreign deposits.
 - 1. Moisture Testing: Perform tests so that each test area does not exceed 200 sq. ft., and perform no fewer than 3 tests in each installation area and with test areas evenly spaced in installation areas.
 - a. Anhydrous Calcium Chloride Test: ASTM F1869. Proceed with installation only after substrates have maximum moisture-vapor-emission rate of 3 lb of water/1,000 sq. ft. in 24 hours.
 - b. Relative Humidity Test: Using in situ probes, ASTM F2170. Proceed with installation only after substrates have a maximum 75 percent relative humidity level measurement.
 - c. Perform additional moisture tests recommended in writing by adhesive and carpet tile manufacturers. Proceed with installation only after substrates pass testing.
- D. Wood Subfloors: Verify the following:
 - 1. Underlayment over subfloor complies with requirements specified in Section 061600 – Sheathing.
 - 2. Underlayment surface is free of irregularities and substances that may interfere with adhesive bond or show through surface.
- E. Proceed with installation only after unsatisfactory conditions have been corrected.

3.2 PREPARATION

- A. General: Comply with the Carpet and Rug Institute's CRI 104 and with carpet tile manufacturer's written installation instructions for preparing substrates indicated to receive carpet tile.
- B. Use trowelable leveling and patching compounds, according to manufacturer's written instructions, to fill cracks, holes, depressions, and protrusions in substrates. Fill or level cracks, holes and depressions 1/8 inch wide or wider, and protrusions more than 1/32 inch unless more stringent requirements are required by manufacturer's written instructions.
- C. Concrete Substrates: Remove coatings, including curing compounds, and other substances that are incompatible with adhesives and that contain soap, wax, oil, or silicone, without using solvents. Use mechanical methods recommended in writing by adhesive and carpet tile manufacturers.
- D. Broom and vacuum clean substrates to be covered immediately before installing carpet tile.
- E. Sound Control Underlayment: Comply with installation requirements in Section 134816 – Manufactured Sound Control Components.

3.3 INSTALLATION OF TILE CARPETING

- A. General: Comply with the Carpet and Rug Institute's CRI 104, Section 10, "Carpet Tile," and with carpet tile manufacturer's written installation instructions.
- B. Installation Method: Manufacturer's recommended self-adhesive tape dots.
- C. Maintain dye-lot integrity. Do not mix dye lots in same area.
- D. Maintain pile-direction patterns recommended in writing by carpet tile manufacturer.
- E. Cut and fit carpet tile to butt tightly to vertical surfaces, permanent fixtures, and built-in furniture including cabinets, pipes, outlets, edgings, thresholds, and nosings. Bind or seal cut edges as recommended by carpet tile manufacturer.
- F. Extend carpet tile into toe spaces, door reveals, closets, open-bottomed obstructions, removable flanges, alcoves, and similar openings.
- G. Maintain reference markers, holes, and openings that are in place or marked for future cutting by repeating on carpet tile as marked on subfloor. Use nonpermanent, nonstaining marking device.
- H. Install pattern parallel to walls and borders.

3.4 CLEANING

- A. Perform the following operations immediately after installing carpet tile:
 - 1. Remove excess adhesive and other surface blemishes using cleaner recommended by carpet tile manufacturer.
 - 2. Remove yarns that protrude from carpet tile surface.
 - 3. Vacuum carpet tile using commercial machine with face-beater element.

3.5 PROTECTION

- A. Protect installed carpet tile to comply with the Carpet and Rug Institute's CRI 104, Section 13.7.
- B. Protect carpet tile against damage from construction operations and placement of equipment and fixtures during remainder of construction period. Use protection methods indicated or recommended in writing by carpet tile manufacturer.

END OF SECTION 096813

SECTION 099000
PAINTING AND COATING

PART 1 - GENERAL

1.1 SUMMARY

A. Section Includes:

1. Surface preparation and application of paint and coating systems on exterior and interior substrates as specified and indicated on Drawings.
2. Items indicated in Specifications to be field-painted.

1.2 DEFINITIONS

A. Paint glosses are defined as sheen ratings of applied paint, according to ASTM D523 and the following MPI values:

1. Gloss Level 1 (Matte or Flat): 0 to 5 units at 60 deg; 10 units maximum at 85 deg.
2. Gloss Level 2 (Velvet): 0 to 10 units at 60 deg; 10 to 35 units at 85 deg.
3. Gloss Level 3 (Eggshell): 10 to 25 units at 60 deg; 10 to 35 units at 85 deg.
4. Gloss Level 4 (Satin): 20 to 35 units at 60 deg, minimum 35 units at 85 deg.
5. Gloss Level 5 (Semi-Gloss): 35 to 70 units at 60 deg.
6. Gloss Level 6 (Gloss): 70 to 85 units at 60 deg.

1.3 ACTION SUBMITTALS

A. Product Data: For each type of product. Include preparation requirements and application instructions.

1. Include Printout of current "MPI Approved Products List" for each product category specified, with proposed product highlighted.
2. Indicate VOC content.

B. Sustainable Design Submittals:

1. Environmental Product Declaration (EPD): For each product.
2. Health Product Declaration (HPD): For each product.
3. Product Data: For paints and coatings, indicating VOC content.
4. Laboratory Test Reports: For paints and coatings, indicating compliance with requirements for low-emitting materials.

C. Samples for Verification: For each type of paint system and in each color and gloss of topcoat.

1. Submit Samples on rigid backing, 8 inches square.
2. Apply coats on Samples in steps to show each coat required for system.
3. Label each coat of each Sample.
4. Label each Sample for location and application area.

D. Product List: For each product indicated, include the following:

1. Cross-reference to paint system and locations of application areas. Use same designations indicated on Drawings and in schedules.
2. Printout of current "MPI Approved Products List" for each product category specified in Part 2, with proposed product highlighted.
3. Color designations.
4. VOC content.

1.4 INFORMATIONAL SUBMITTALS

A. Applicator qualifications.

1.5 MAINTENANCE MATERIAL SUBMITTALS

- A. Furnish extra materials, from same product run, that match products installed and that are packaged with protective covering for storage and identified with labels describing contents.
 - 1. Paint: 5 percent, but not less than 1 gal. of each material and color applied.

1.6 QUALITY ASSURANCE

- A. Applicator Qualifications: Company specializing in performing type of work of this Section with a minimum of 3 years documented experience.
- B. Mockups: Apply mockups of each paint system indicated and each color and finish selected to verify preliminary selections made under Sample submittals and to demonstrate aesthetic effects and set quality standards for materials and execution.
 - 1. Architect will select one surface to represent surfaces and conditions for application of each paint system.
 - a. Vertical and Horizontal Surfaces: Provide samples of at least 100 sq. ft.
 - b. Other Items: Architect will designate items or areas required.
 - 2. Final approval of color selections will be based on mockups.
 - a. If preliminary color selections are not approved, apply additional mockups of additional colors selected by Architect at no added cost to Owner.
 - 3. Approval of mockups does not constitute approval of deviations from Contract Documents contained in mockups unless Architect specifically approves such deviations in writing.
 - 4. Subject to compliance with requirements, approved mockups may become part of completed Work if undisturbed at time of Substantial Completion.

1.7 DELIVERY, STORAGE, AND HANDLING

- A. Store materials not in use in tightly covered containers in well-ventilated areas with ambient temperatures continuously maintained at not less than 45 deg F.
 - 1. Maintain containers in clean condition, free of foreign materials and residue.
 - 2. Remove rags and waste from storage areas daily.

1.8 FIELD CONDITIONS

- A. Apply paints only when temperature of surfaces to be painted and ambient air temperatures are between 50 and 95 deg F.
- B. Do not apply paints when relative humidity exceeds 85 percent; at temperatures less than 5 deg F above the dew point; or to damp or wet surfaces.

PART 2 - PRODUCTS

2.1 MANUFACTURERS

- A. Manufacturers: Subject to compliance with requirements, provide products by the following:
 - 1. Benjamin Moore & Co.
 - 2. Cloverdale Paint Inc.
 - 3. Diamond Vogel Paints.
 - 4. Glidden Professional.
 - 5. Kelly-Moore Paint Company Inc.
 - 6. Miller Paint Company, Inc.
 - 7. PPG Architectural Finishes, Inc.
 - 8. Rodda Paint Co.
 - 9. Rust-Oleum Corporation.
 - 10. Sherwin-Williams Company (The).

2.2 PAINT, GENERAL

- A. MPI Standards: Provide products complying with MPI standards indicated and listed in its "MPI Approved Products Lists."
 - 1. If a manufacturer produces more than one product within an MPI category, provide highest quality product within that category.
- B. Material Compatibility:
 - 1. Provide materials for use within each paint system that are compatible with one another and substrates indicated, under conditions of service and application as demonstrated by manufacturer, based on testing and field experience.
 - 2. For each coat in a paint system, provide products recommended in writing by topcoat manufacturers for use in paint system and on substrate indicated.
 - 3. Provide products of same manufacturer for each coat in a coating system.
- C. Material Quality: Material containers not displaying coating manufacturer's product identification will not be accepted.
- D. VOC Content: For field applications that are inside weatherproofing system, verify paints and coatings comply with VOC content limits of authorities having jurisdiction and the following VOC content limits.
 - 1. Flat Paints and Coatings: 50 g/L.
 - 2. Nonflat Paints and Coatings: 50 g/L.
 - 3. Primers, Sealers, and Undercoaters: 100 g/L.
 - 4. Rust-Preventive Coatings: 100 g/L.
 - 5. Zinc-Rich Industrial Maintenance Primers: 100 g/L.
 - 6. Pretreatment Wash Primers: 420 g/L.
 - 7. Floor Coatings: 50 g/L.
 - 8. Shellacs, Clear: 730 g/L.
 - 9. Shellacs, Pigmented: 550 g/L.
- E. Low-Emitting Materials: For field applications that are inside weatherproofing system, verify 90 percent of paints and coatings comply with requirements of California Department of Public Health's "Standard Method for the Testing and Evaluation of Volatile Organic Chemical Emissions from Indoor Sources Using Environmental Chambers."
- F. Colors: See Finish Legend on Drawings for selected paint and coating colors.

2.3 BLOCK FILLERS

- A. Block Filler, Latex, Interior/Exterior: MPI #4.
 - 1. Products: Subject to compliance with requirements, provide one of the following:
 - a. Benjamin Moore: Coronado, Super Kote 5000 Latex Prod. Block Filler Flat, 958.
 - b. PPG Architectural, PPG, Speedhide Int/ Ext Masonry Hi Fill Latex Block Filler, 6-15XI.
 - c. Rodda Paint Co.: Rodda Paint Co., Sprayable Smooth Block Filler, 501901.
 - d. Sherwin-Williams: PrepRite, Int/Ext Block Filler, B25W00025.

2.4 GALVANIZED METAL CLEANERS/ETCHING

- A. Cleaning, Etching, for Steel, Galvanized Metal: MPI #25.
 - 1. Products: Subject to compliance with requirements, provide one of the following:
 - a. Cloverdale Paint: Cloverdale, ClovaClean, 78100.
 - b. Rust-Oleum: Krud Kutter, Metal Clean and Etch, ME326 or ME014.
 - c. Sherwin-Williams: Great Lakes Laboratories, Clean'n Etch, 899.
 - 2. Field-Applied Etching Cleaner: Use in lieu of SSPC-SP 1 Solvent Cleaning, specified under preparation. Not required for shop primed ferrous metal.

2.5 PRIMERS/SEALERS

- A. Primer Sealer, Latex, Interior: MPI #50.
1. Products: Subject to compliance with requirements, provide one of the following:
 - a. Benjamin Moore: Coronado, Super Kote 5000 Latex Primer-Sealer, 40-11.
 - b. Benjamin Moore: Ultra Spec 500, Interior Flat Finish, N534/K534.
 - c. Kelly-Moore: 971 Acryplex, Acryplex Interior PVA Primer Sealer, 971-100.
 - d. Miller Paint: Miller Paint, Premium PVA Primer, 220011.
 - e. PPG Architectural: Glidden Professional (US), PVA Drywall Interior Primer and Sealer, GPD-0000.
 - f. PPG Architectural: PPG Paints, Speedhide Zero Interior Zero VOC Latex Sealer, 6-4900XI.
 - g. Rodda Paint Co.: Master Painter, UL Primer, 503601.
 - h. Sherwin-Williams: ProMar 200 Zero, Interior Latex Primer, B28W02600.
- B. Primer Sealer, Latex, Interior: MPI #61.
1. Products: Subject to compliance with requirements, provide one of the following:
 - a. Benjamin Moore: Ultra Spec, Latex Vapor Barrier Primer Sealer, 573/K573.
 - b. PPG Architectural: PPG Paints, Seal Grip Perm Sealer Vapor Barrier, 17-9801.
 - c. Rodda Paint: Interior Perm Rated Primer/Sealer, Vapor Block, 507901.
 - d. Sherwin-Williams: Vapor Barrier, Moisture Vapor Barrier, B72W00011.
 2. Product that provides vapor barrier qualities.
- C. Primer, Alkali Resistant, Water Based: MPI #3.
1. Products: Subject to compliance with requirements, provide one of the following:
 - a. Benjamin Moore: Ultra Spec, Interior/Exterior Acrylic High-Build Masonry Primer, 609.
 - b. Cloverdale Paint: Prime Solution, Alkali Resistant Primer, 05133.
 - c. Kelly-Moore: 247 AcryShield, AcryShield Acrylic Exterior Masonry Primer, 247-100.
 - d. Miller Paint: Kril, Ext/Int Acrylic Primer/Sealer, 620011.
 - e. PPG Architectural: PPG Paints, Perma-Crete Interior/Exterior Alkali Resistant Primer, 4-603XI Series.
 - f. Rodda Paint Co.: Prime Solutions, First Coat Universal Bonding Primer, 501601.
 - g. Sherwin-Williams: Loxon, Loxon Concrete & Masonry Primer, LX02 Series.

2.6 METAL PRIMERS

- A. Primer, Rust-Inhibitive, Water Based, MPI #107.
1. Products: Subject to compliance with requirements, provide one of the following:
 - a. Benjamin Moore: Ultra Spec HP, Acrylic Metal Primer, HP04/FP04.
 - b. Cloverdale Paint, Cloverdale Paint, Ecologic Water Borne Shop Primer, 7032 Series.
 - c. Sherwin-Williams: Pro Industrial, Pro-Cryl Universal Primer, B66W1310.
- B. Primer, Alkyd, Anti-Corrosive, for Metal: MPI #79.
1. Products: Subject to compliance with requirements, provide one of the following:
 - a. AkzoNobel, Devoe High Performance Coatings, Devprime 1409, 1409.
 - b. Benjamin Moore: Corotech, Aliphatic Acrylic Urethane Semi-Gloss, V510.
 - c. Benjamin Moore: Super Spec HP, D.T.M. Alkyd Low Lustre, P23.
 - d. Cloverdale Paint, Cloverdale Paint, Metal Primer Grey, 71307/71309.
 - e. PPG Architectural: Protective and Marine Coatings, Multiprime 4160/Devguard 4160, 4160.
 - f. Rodda Paint Co.: Industrial Primer, Barrier III HS, 708225.
 - g. Sherwin-Williams: Protective & Marine, Kem Kromik Universal Primer, B50WZ Series.
 2. Application: Anti-corrosive primer for ferrous metals in industrial or light marine exposures.

- C. Primer, Galvanized, Water Based: MPI #134.
 - 1. Products: Subject to compliance with requirements, provide one of the following:
 - a. Benjamin Moore: Ultra Spec HP, Acrylic Metal Primer, HP04/FP04.
 - b. Cloverdale Paint, Prime Solutions, Ecologic Waterborne Rustex Primer, 7032 Series.
 - c. Kelly-Moore: 5725 DTM, DTM Acrylic Primer Finish, 5725-100.
 - d. Miller Paint: Acrimetel, Acrimetel DTM Primer/Finish Velvet, 310-2-10.
 - e. Rodda Paint Co.: Prime Solutions, First Coat Bonding Primer, 501601.
 - f. PPG Architectural: High Performance Coatings, Pitt-Tech Plus 4020, 4020 1000.
 - g. Sherwin-Williams: Pro Industrial, Pro-Cryl Universal Primer, B66W1310.
- D. Primer, Vinyl Wash, MPI #80.
 - 1. Products: Subject to compliance with requirements, provide one of the following:
 - a. Sherwin-Williams: Product Finishes, Industrial Wash Primer, P60G2/R7K44.
 - b. Approved substitution.

2.7 WOOD PRIMERS:

- A. Primer, Latex for Exterior Wood: MPI #6.
 - 1. Products: Subject to compliance with requirements, provide one of the following:
 - a. Benjamin Moore: Insl-X, Prime All Multi-Surface Latex Primer, AP-1000.
 - b. Cloverdale Paint: Prime Solution, Acrylic Latex Stain Blocking Primer, 05130.
 - c. Kelly-Moore: 255 AcryShield, AcryShield 100% Acrylic Exterior Wood Primer, 255-100.
 - d. Miller Paint: Miller-Prime, Int/Ext All Purpose Stain Blocking Primer, 470011.
 - e. PPG Architectural: Glidden Professional (US), Gripper Interior/Exterior Primer and Sealer, GPG-0000.
 - f. PPG Architectural: PPG Paints, Seal Grip Interior/Exterior Acrylic Universal Primer/Sealer, 17-921XI.
 - g. Rodda Paint Co.: Prime Solutions, First Coat Universal Bonding Primer, 501601.
 - h. Rust-Oleum: Zinsser, Bulls Eye 123 Plus, 249937.
 - i. Sherwin-Williams: PrepRite ProBlock Primer/Sealer, Interior/Exterior Latex, B51W00620.
- B. Primer, Latex, for Interior Wood, MPI #39.
 - 1. Products: Subject to compliance with requirements, provide one of the following:
 - a. Benjamin Moore: Insl-X, Prime All Multi-Surface Latex Primer, AP-1000.
 - b. Diamond Vogel: Mill Max, Latex Enamel Undercoat, DU-1508.
 - c. Cloverdale Paint: Prime Solution, Acrylic Latex Stain Blocking Primer, 05130.
 - d. Kelly-Moore: 973 Acryplex, Acryplex Interior Enamel Undercoat, 973-100.
 - e. PPG Architectural: Glidden Professional (US), Gripper Interior/Exterior Primer and Sealer, GPG-0000.
 - f. PPG Architectural: PPG Paints, Seal Grip Interior/Exterior Acrylic Universal Primer/Sealer, 17-921XI Series.
 - g. Rodda Paint Co.: Unique II, 100% Acrylic Enamel Undercoat, 502001.
 - h. Rust-Oleum: Zinsser, Bulls Eye 123 Plus, 249937.
 - i. Sherwin-Williams: PrepRite ProBlock, Primer Sealer, B51W00620.

2.8 WATER-BASED PAINTS

- A. Latex, Exterior, Flat (MPI Gloss Level 1), MPI #10.
 - 1. Products: Subject to compliance with requirements, provide one of the following:
 - a. Benjamin Moore: Coronado, Cryli Cote 100% Acrylic Flat Exterior Paint, 10.
 - b. Benjamin Moore: Ultra Spec, Exterior Flat Finish, N447/K447.
 - c. Cloverdale Paint: WeatherOne, Covercoat Flat Latex White, 02203.
 - d. Diamond Vogel: EverCryl, Exterior 100% Acrylic Latex Exterior Flat, BF-1655.
 - e. Kelly-Moore: 1240 AcryShield, 100% Acrylic Exterior Flat, 1240A-121.
 - f. Miller Paint: Kril, Acrylic Exterior Flat, 520110.

- g. PPG Architectural: PPG Paints, Speedhide Zero Interior Zero VOC Latex Semi-Gloss, 6-610XI.
 - h. Sherwin-Williams: A-100, Exterior Latex Flat, A06W00151.
- B. Latex, Exterior Low Sheen (MPI Gloss Level 3-4), MPI #15.
 - 1. Products: Subject to compliance with requirements, provide one of the following:
 - a. Benjamin Moore: Ultra Spec EXT, Exterior Satin Finish, N448/K448.
 - b. Cloverdale Paint: Master Painter, Exterior 100% Acrylic Latex Finish Satin, 02020.
 - c. Diamond Vogel: EverCryl, Exterior 100% Acrylic Latex Exterior Satin, BS-1655.
 - d. Kelly-Moore: AcryShield, AcryShield 100% Acrylic Exterior Satin, 1247-121.
 - e. Miller Paint: Kril, 100% Acrylic Exterior Satin, 520410.
 - f. PPG Architectural: Glidden (US), Premium Exterior Latex Satin Paint, GL6911 Series.
 - g. PPG Architectural: PPG Paints, Speedhide Exterior 100% Acrylic Latex Satin, 6-2045XI Line.
 - h. Sherwin-Williams: A-100, Exterior Latex Semi-Gloss, A08W00251.
- C. Latex, Interior, Flat, (MPI Gloss Level 1), MPI #53.
 - 1. Products: Subject to compliance with requirements, provide one of the following:
 - a. Benjamin Moore: Coronado, Super Kote 5000 Zero VOC Acrylic Latex Flat, 501.
 - b. Benjamin Moore: Ultra Spec 500, Interior Flat Finish, N536.
 - c. Cloverdale Paint: Master Painter, Flat Interior Latex White, 07360.
 - d. Kelly-Moore, 1602 AcryPlex Interior Flat Paint, 1602 AcryPlex Interior Flat Paint, 1602121.
 - e. Miller Paint, Premium, Interior Latex Flat, 120110.
 - f. PPG Architectural: PPG Paints, Speedhide Zero Interior Zero VOC Latex Flat, 6-4110XI.
 - g. Rodda Paint Co.: Rodda Paint, Master Painter Ultra Low VOC Flat, 513601.
 - h. Sherwin-Williams: ProMar 200 Zero VOC, Interior Latex Flat, B30W12651.
- D. Latex, Interior, Semi-Gloss, (MPI Gloss Level 5), MPI #54.
 - 1. Products: Subject to compliance with requirements, provide one of the following:
 - a. Benjamin Moore: Regal Select, Premium Interior Paint & Primer Semi-Gloss Finish, 551/K551.
 - b. PPG Architectural: PPG Paints, Speedhide Pro-EV Zero Interior Wall & Ceiling Latex Semi-gloss, 12-510XI.
 - c. PPG Architectural: PPG Paints, Speedhide Zero Interior Zero VOC Latex Flat, 6-4510XI.
 - d. Rodda Paint Co.: Rodda Paint Co., Master Painter Ultra Low VOC Semi Gloss Enamel, 543601.
 - e. Sherwin-Williams: ProMar 200 Zero VOC, Interior Latex Gloss, B21W12651.
 - 2. Application: Mildew-resistant coating for use in areas subject to mold and mildew.
- E. Latex, Interior, (MPI Gloss Level 3), MPI #52.
 - 1. Products: Subject to compliance with requirements, provide one of the following:
 - a. Benjamin Moore: Super Hide, Zero VOC Interior Eggshell, 357/K357.
 - b. Kelly-Moore, 1686 Dura-Poxy, DuraPoxy 100% Eggshell Acrylic Enamel, 1686121.
 - c. Miller Paint, Premium, Interior Satin Wall Finish, 120410.
 - d. PPG Architectural: PPG Paints, Speedhide Zero Interior Zero VOC Latex Satin, 6-4410XI.
 - e. Rodda Paint Co.: Rodda Paint Co., Master Painter UL VOC Eggshell White, 573651.
 - f. Sherwin-Williams: ProMar 200 Zero VOC, Interior Latex Eg-Shel, B20W12651.

- F. Latex, Interior, High Performance Architectural, Semi-Gloss (MPI Gloss Level 5), MPI #141.
 - 1. Products: Subject to compliance with requirements, provide one of the following:
 - a. Benjamin Moore: Ultra Spec 500, Interior Gloss, N540/K540.
 - b. Cloverdale Paint: Performance Plus, High Performance Ultra Low VOC Ecologic Waterborne GL5 Semi-Gloss White, 70623.
 - c. Kelly-Moore: 1685 DuraPoxy, DuraPoxy 100% Acrylic Semi-Gloss Enamel, 1685-121.
 - d. Miller Paint: Acrinamel, 100% Acrylic Multipurpose Enamel Semi-Gloss, 320510.
 - e. PPG Architectural: PPG Paints, Pure Performance Interior Semi-Gloss, 9-510XI Series.
 - f. Sherwin-Williams, Pro Industrial, Acrylic Semi-Gloss Coating, B66W00651.
- G. Light Industrial Coating, Interior, Water Based (MPI Gloss Level 3), MPI #151.
 - 1. Products: Subject to compliance with requirements, provide one of the following:
 - a. Cloverdale Paint: EcoLogic, Ultra Low VOC Ecologic Waterborne GL3 Pearl White, 70653.
 - b. PPG Architectural: High Performance Coatings, Pitt-Tech Plus Int/Ext Satin DTM Industrial Enamel, 90-1110.
 - c. Rodda Paint Co.: Rodda Paint, Multi Master DTM Satin, 528901.
 - d. Sherwin-Williams: Pro Industrial, DTM Acrylic Eg-Shel, B66W01251.
- H. Light Industrial Coating, Interior, Water Based, Semi-Gloss (MPI Gloss Level 5), MPI #153.
 - 1. Products: Subject to compliance with requirements, provide one of the following:
 - a. AkzoNobel, Devco High Performance Coatings, Devcryn 1448, 1448.
 - b. Benjamin Moore: Corotech, DTM Acrylic Semi-Gloss, V331.
 - c. Cloverdale Paint: EcoLogic, Zero VOC Ecologic Waterborne GL5 Semi-Gloss White, 70623.
 - d. Diamond Vogel: Eas-E-Poxy, Pre-Catalyzed WB Epoxy Semi-Gloss, MS-1575.
 - e. Kelly-Moore: DuraPoxy, 1685 DuraPoxy Interior Semi-Gloss Enamel, 1685121.
 - f. Miller Paint: Acrinamel, Acrimetal DTM Semi-Gloss, 310510.
 - g. PPG Architectural: High Performance Coatings, Pitt-Tech Plus SG 4216 HP/Devflex 4216 HP, 4216HP.
 - h. Sherwin-Williams: Protective & Marine, Sher-Cryl HPA Semi-Gloss, B66W00351

2.9 DRY FOG/FALL COATINGS

- A. Dry Fall, Latex, Flat (MPI Gloss Level 1), MPI #118.
 - 1. Products: Subject to compliance with requirements, provide one of the following:
 - a. Benjamin Moore: Coronado, Super Kote 5000 Dry Fall Acrylic Latex Flat, N110.
 - b. Cloverdale Paint: Cloverdale, Latex Acrylic Fall Flat, 05138.
 - c. Diamond Vogel: Luminance 300, Latex Dri-Mist Flat, MV-1518.
 - d. Kelly-Moore; Dry Fog II, Dry Fog II Flat Latex Maintenance Finish, 480-100.
 - e. Miller Paint: Miller Paint, Aqua Fall, 181111.
 - f. PPG Architectural: PPG Paints, Speedhide Super Tech WB Interior Dry Fog Flat Latex, 6-725XI.
 - g. Rodda Paint Co.: Professional Maintenance, W.B Dry Fog Coating, 513801.
 - h. Sherwin-Williams: Pro Industrial, Waterborne Acrylic Dryfall, B42W00181.

PART 3 - EXECUTION

3.1 EXAMINATION

- A. Examine substrates and conditions, with Applicator present, for compliance with requirements for maximum moisture content and other conditions affecting performance of Work.

- B. Maximum Moisture Content of Substrates: When measured with an electronic moisture meter as follows:
 - 1. Concrete: 12 percent.
 - 2. Fiber-Cement Board: 12 percent.
 - 3. Wood: 15 percent.
 - 4. Gypsum Board: 12 percent.
- C. Gypsum Board Substrates: Verify that finishing compound is sanded smooth.
- D. Verify suitability of substrates, including surface conditions and compatibility, with existing finishes and primers.
- E. Proceed with coating application only after unsatisfactory conditions have been corrected.
 - 1. Application of coating indicates acceptance of surfaces and conditions.

3.2 PREPARATION

- A. Comply with manufacturer's written instructions and recommendations in "MPI Architectural Painting Specification Manual" applicable to substrates and paint systems indicated.
- B. Remove hardware, covers, plates, and similar items already in place that are removable and are not to be painted. If removal is impractical or impossible because of size or weight of item, provide surface-applied protection before surface preparation and painting.
 - 1. After completing painting operations, use workers skilled in trades involved to reinstall items that were removed. Remove surface-applied protection if any.
- C. Clean substrates of substances that could impair bond of paints, including dust, dirt, oil, grease, and incompatible paints and encapsulants.
 - 1. Remove incompatible primers and reprime substrate with compatible primers or apply tie coat as required to produce paint systems indicated.
- D. Concrete Substrates: Remove release agents, curing compounds, efflorescence, and chalk. Do not paint surfaces if moisture content or alkalinity of surfaces to be painted exceeds that permitted in manufacturer's written instructions.
- E. Masonry Substrates: Remove efflorescence and chalk. Do not paint surfaces if moisture content or alkalinity of surfaces or mortar joints exceeds that permitted in manufacturer's written instructions.
- F. Steel Substrates: Remove rust, loose mill scale, and shop primer, if any. Clean using methods recommended in writing by paint manufacturer but not less than the following:
 - 1. Interior Steel: SSPC-SP 3.
 - 2. Exterior Steel: SSPC-SP 6 (WAB)/NACE WAB-3.
- G. Shop-Primed Steel Substrates: Clean field welds, bolted connections, and areas where shop paint is abraded. Paint exposed areas with the same material as used for shop priming to comply with SSPC-PA 1 for touching up shop-primed surfaces.
- H. Galvanized-Metal Substrates: Remove grease and oil residue from galvanized sheet metal by mechanical methods to produce clean, lightly etched surfaces that promote adhesion of subsequently applied paints.
- I. Aluminum Substrates: Remove loose surface oxidation.
- J. Wood Substrates:
 - 1. Scrape and clean knots, and apply coat of knot sealer before applying primer.
 - 2. Sand surfaces that will be exposed to view, and dust off.
 - 3. Prime edges, ends, faces, undersides, and backsides of wood.
 - 4. After priming, fill holes and imperfections in the finish surfaces with putty or plastic wood filler. Sand smooth when dried.

- K. Cotton or Canvas Insulation Covering Substrates: Remove dust, dirt, and other foreign material that might impair bond of paints to substrates.

3.3 APPLICATION

- A. Apply paints according to manufacturer's written instructions and to recommendations in "MPI Manual."
 - 1. Use applicators and techniques suited for paint and substrate indicated.
 - 2. Paint surfaces behind movable equipment and furniture same as similar exposed surfaces. Before final installation, paint surfaces behind permanently fixed equipment or furniture with prime coat only.
 - 3. Paint front and backsides of access panels, removable or hinged covers, and similar hinged items to match exposed surfaces.
 - 4. Do not paint over labels of independent testing agencies or equipment name, identification, performance rating, or nomenclature plates.
 - 5. Primers specified in painting schedules may be omitted on items that are factory primed or factory-finished if acceptable to topcoat manufacturers.
- B. Tint each undercoat a lighter shade to facilitate identification of each coat if multiple coats of same material are to be applied. Tint undercoats to match color of topcoat, but provide sufficient difference in shade of undercoats to distinguish each separate coat.
- C. If undercoats or other conditions show through topcoat, apply additional coats until cured film has a uniform paint finish, color, and appearance.
- D. Apply paints to produce surface films without cloudiness, spotting, holidays, laps, brush marks, roller tracking, runs, sags, ropiness, or other surface imperfections. Cut in sharp lines and color breaks.
- E. Painting Fire Suppression, Plumbing, HVAC, Electrical, Communication, and Electronic Safety and Security Work:
 - 1. Paint the following Work where exposed in equipment rooms:
 - a. Equipment, including panelboards and switch gear.
 - b. Uninsulated metal piping.
 - c. Uninsulated plastic piping.
 - d. Pipe hangers and supports.
 - e. Metal and plastic conduit.
 - f. Tanks that do not have factory-applied final finishes.
 - g. Duct, equipment, and pipe insulation having cotton or canvas insulation covering or other paintable jacket material.
 - 2. Paint the following Work where exposed in occupied spaces:
 - a. Equipment, including panelboards.
 - b. Uninsulated metal or plastic piping.
 - c. Pipe hangers and supports.
 - d. Metal and plastic conduit.
 - e. Duct, equipment, and pipe insulation having cotton or canvas insulation covering or other paintable jacket material.
 - f. Other items as directed by Architect.
 - 3. Paint portions of internal surfaces of metal ducts, without liner, behind air inlets and outlets that are visible from occupied spaces.

3.4 FIELD QUALITY CONTROL

- A. Dry Film Thickness Testing: Owner may engage services of a qualified testing and inspecting agency to inspect and test paint for dry film thickness.
 - 1. Touch up and restore painted surfaces damaged by testing.

2. If test results show that dry film thickness of applied paint does not comply with paint manufacturer's written recommendations, pay for testing and apply additional coats as needed to provide dry film thickness that complies with paint manufacturer's written recommendations.

3.5 CLEANING

- A. At end of each workday, remove rubbish, empty cans, rags, and other discarded materials from Project site.
- B. After completing paint application, clean spattered surfaces. Remove spattered paints by washing, scraping, or other methods. Do not scratch or damage adjacent finished surfaces.

3.6 PROTECTION

- A. Protect Work of other trades against damage from paint application. Correct damage to Work of other trades by cleaning, repairing, replacing, and refinishing, as approved by Architect, and leave in an undamaged condition.
- B. At completion of construction activities of other trades, touch up and restore damaged or defaced painted surfaces.

3.7 COLOR SCHEDULE

- A. Colors: Provide colors listed in Finish Legend on Drawings.

3.8 EXTERIOR PAINTING SCHEDULE

- A. Concrete Substrates, Nontraffic Surfaces:
 1. Latex System:
 - a. Prime Coat: Primer, alkali resistant, water based, MPI #3.
 - b. Intermediate Coat: Latex, exterior, matching topcoat.
 - c. Topcoat: Latex, exterior, low sheen (MPI Gloss Level 3-4), MPI #15.
 - d. Applications:
 - 1) Vertical cast-in-place concrete conditions.
- B. Cement Board . Substrates:
 1. Latex System:
 - a. Prime Coat: Primer, alkali resistant, water based, MPI #3.
 - b. Intermediate Coat: Latex, exterior, matching topcoat.
 - c. Topcoat: Latex, exterior, flat (MPI Gloss Level 1), MPI #10.
 - d. Topcoat: Latex, exterior, low sheen (MPI Gloss Level 3-4), MPI #15.
 - e. Applications:
 - 1) Fiber-cement planks, panels, trim, and related materials.
 - f. Sheen:
 - 1) Flat: Soffits and other covered, horizontal conditions.
 - 2) Low Sheen: Vertical conditions.
- C. CMU Substrates:
 1. Specified in Section 099600 – High Performance Coatings.
- D. Steel Substrates:
 1. Specified in Section 099600 – High Performance Coatings.
- E. Galvanized-Metal Substrates:
 1. Specified in Section 099600 – High Performance Coatings.
- F. Wood Substrates: Wood-based panel products.

- G. Wood Substrates: Wood trim.
 - 1. Latex over Latex Primer System:
 - a. Prime Coat: Primer, latex for exterior wood, MPI #6.
 - b. Intermediate Coat: Latex, exterior, matching topcoat.
 - c. Topcoat: Latex, exterior, low sheen (MPI Gloss Level 3-4), MPI #15.

- H. Exterior Gypsum Board Substrates:
 - 1. Latex System:
 - a. Prime Coat: Primer, latex for exterior wood (reduced), MPI #6.
 - b. Intermediate Coat: Latex, exterior, matching topcoat.
 - c. Topcoat: Latex, exterior, flat (MPI Gloss Level 1), MPI #10.
 - d. Applications:
 - 1) Gypsum board soffits.

- I. Cotton or Canvas Insulation-Covering Substrates:
 - 1. Latex System:
 - a. Prime Coat: Latex, exterior, matching topcoat.
 - b. Intermediate Coat: Latex, exterior, matching topcoat.
 - c. Topcoat: Latex, exterior, flat (MPI Gloss Level 1), MPI #10.
 - d. Application:
 - 1) Includes pipe and duct coverings.

3.9 INTERIOR PAINTING SCHEDULE

- A. Concrete Substrates, Nontraffic Surfaces:
 - 1. Latex System:
 - a. Prime Coat: Primer, alkali resistant, water based, MPI #3.
 - b. Intermediate Coat: Latex, interior, matching topcoat.
 - c. Topcoat: Latex, interior, semi-gloss (MPI Gloss Level 5), MPI #54.
 - d. Application:
 - 1) Vertical concrete surfaces not subject to traffic that are not covered in Section 099600.
- B. Steel Substrates:
 - 1. High-Performance Architectural Latex System:
 - a. Prime Coat: Primer, alkyd, anti-corrosive, for metal[, MPI #79].
 - b. Prime Coat: Shop primer specified in Section where substrate is specified.
 - c. Intermediate Coat: Latex, interior, high performance architectural, matching topcoat.
 - d. Topcoat: Latex, interior, high performance architectural, semi-gloss (MPI Gloss Level 5)[, MPI #141].
 - 2.
 - 3. High Performance Architectural Latex System:
 - a. Prime Coat: Primer, rust-inhibitive, water based, MPI #107.
 - b. Intermediate Coat: Latex, interior, high performance architectural, matching topcoat.
 - c. Topcoat (PS3): (MPI Gloss Level 5), MPI #141.
 - d. Applications:
 - 1) Miscellaneous metals other than hollow metal doors and frames, and pipe and tube railings.
 - 4.
 - 5.
 - 6.
 - 7. Water-Based Light Industrial Coating System:
 - a. Prime Coat: Primer, rust-inhibitive, water based, MPI #107.
 - b. Intermediate Coat: Light industrial coating, interior, water based, matching topcoat.
 - c. Topcoat (PS13): (MPI Gloss Level 5), MPI #153.
 - d. Applications:

- 1) Hollow metal doors and frames, and pipe and tube railings that are not covered in Section 099600.
8. Water-Based Dry-Fall System:
 - a. Prime Coat: Shop primer specified in Section where substrate is specified.
 - b. Topcoat: Dry fall, latex, flat, MPI #118.
 - c. Applications:
 - 1) Interior, exposed-to-view, overhead-mounted services in utilitarian spaces, including shop primed steel deck, structural steel, and metal fabrications.
- C. Galvanized Metal Substrates:
 1. High Performance Architectural Latex System:
 - a. Prime Coat: Primer, galvanized, water based, MPI #134.
 - b. Intermediate Coat: Interior, matching topcoat.
 - c. Topcoat: Latex, interior, high performance architectural, semi-gloss (MPI Gloss Level 5), MPI #141.
 - d. Applications:
 - 1) Miscellaneous galvanized metals other than hollow metal doors and frames, pipe and tube railings.
 2. Water-Based Dry-Fall System:
 - a. Prime Coat: Dry fall, water based, for galvanized steel, matching topcoat.
 - b. Intermediate Coat: Interior, matching topcoat.
 - c. Topcoat: Dry fall, water based, for galvanized steel, flat (MPI Gloss Level 1), MPI #133.
 - d. Applications:
 - 1) Interior, exposed-to-view, overhead-mounted services in utilitarian spaces, including galvanized ducts, galvanized conduit, and galvanized piping
- D. Wood Substrates:
 1. Latex over Latex Primer System:
 - a. Prime Coat: Primer, latex, for interior wood, MPI #39.
 - b. Topcoat: Latex, interior, semi-gloss (MPI Gloss Level 5), MPI #54.
 2. Applications:
 - a. Plywood backing panels.
- E. Gypsum Board Substrates:
 1. Latex over Latex Sealer System:
 - a. Prime Coat: Primer sealer, latex, interior, MPI #50.
 - b. Intermediate Coat: Latex, interior, matching topcoat.
 - c. Topcoat: Latex, interior, flat (MPI Gloss Level 1), MPI #53.
 - d. Topcoat: Latex, interior, eggshell (MPI Gloss Level 3), MPI #52.
 - e. Topcoat: Latex, interior, semi-gloss (MPI Gloss Level 5), MPI #54.
 - f. Application:
 - 1) Interior gypsum board not at exterior wall conditions and not scheduled for High Performance Coatings.
 - g. Sheen:
 - 1) Flat: Soffits and ceilings.
 - 2) Eggshell: Walls and other vertical conditions unless indicated otherwise.
 - 3) Semi-Gloss: Janitorial and maintenance rooms, toilet rooms, and other surfaces requiring semi-gloss finish that are not scheduled in Section 099600.
 - h. Note: Ensure surfaces receiving MPI #54 topcoat have a Level 5 drywall finish.
 2. Latex over Latex Sealer System Low Permeability:
 - a. Prime Coat: Primer sealer, low permeability, latex, interior, MPI #61.
 - b. Intermediate Coat: Latex, interior, matching topcoat.
 - c. Topcoat: Latex, interior, eggshell (MPI Gloss Level 3), MPI #52.
 - d. Application:
 - 1) Interior gypsum board at exterior wall conditions.
 - 2) Interior partitions schedule to receive wall covering.

- F. Cotton or Canvas Insulation-Covering Substrates:
 - 1. Latex System:
 - a. Prime Coat: Primer sealer, latex, interior, MPI #50.
 - b. Intermediate Coat: Latex, interior, matching topcoat.
 - c. Topcoat: Latex, interior, flat (MPI Gloss Level 1), MPI #53.
 - d. Application:
 - 1) Pipe and duct coverings.

END OF SECTION 099000

SECTION 099600
HIGH-PERFORMANCE COATINGS

PART 1 - GENERAL

1.1 SUMMARY

A. Section Includes:

1. Surface preparation and application of high-performance coating systems used on the following vertical and horizontal substrates:
 - a. Concrete **[vertical] [and] [horizontal]** surfaces.
 - b. **[Concrete masonry units (CMUs).]**
 - c. Steel.
 - d. Galvanized steel.
 - e. Architecturally exposed structural steel.

1.2 DEFINITIONS

A. Paint glosses are defined as sheen ratings of applied paint, according to ASTM D523:

1. MPI Gloss Level 5 (Semi-Gloss): 35 to 70 units at 60 deg.
2. MPI Gloss Level 6 (Gloss): 70 to 85 units at 60 deg.

1.3 ACTION SUBMITTALS

A. Product Data: For each type of product indicated.

1. Indicate VOC content.
2. Include preparation requirements and application instructions.

B. Sustainable Design Submittals:

1. Environmental Product Declaration (EPD): For each product.
2. Health Product Declaration (HPD): For each product.
3. Product Data: For paints and coatings, indicating VOC content.
4. Laboratory Test Reports: For paints and coatings, indicating compliance with requirements for low-emitting materials.

C. Samples for Verification: For each type of coating system and in each color and gloss of topcoat indicated.

1. Submit Samples on rigid backing, 8 inches square.
2. Step coats on Samples to show each coat required for system.
3. Label each coat of each Sample.
4. Label each Sample for location and application area.

D. Product List: For each product indicated, include the following:

1. Cross-reference to paint system and locations of application areas. Use same designations indicated on Drawings and in schedules.
2. Printout of current "MPI Approved Products List" for each product category specified in Part 2, with proposed product highlighted.
3. Color designations.
4. VOC content.

1.4 INFORMATIONAL SUBMITTALS

A. Applicator qualifications.

1.5 MAINTENANCE MATERIAL SUBMITTALS

- A. Furnish extra materials, from same product run, that match products installed and that are packaged with protective covering for storage and identified with labels describing contents.
 - 1. Coatings: 5 percent, but not less than 1 gal. of each material and color applied.

1.6 QUALITY ASSURANCE

- A. Applicator Qualifications: Company specializing in performing type of work of this Section with a minimum of 3 years documented experience.
- B. Mockups: Apply mockups of coating system indicated to verify preliminary selections made under Sample submittals, to demonstrate aesthetic effects, and set quality standards for materials and execution.
 - 1. Architect will select 1 surface to represent surfaces and conditions for application of each coating system specified in Part 3.
 - a. Provide samples of at least 100 sq. ft.
 - b. Other Items: Architect will designate items or areas required.
 - 2. Final approval of color selections will be based on mockups.
 - a. If preliminary color selections are not approved, apply additional mockups of additional colors selected by Architect at no added cost to Owner.
 - 3. Approval of mockups does not constitute approval of deviations from Contract Documents contained in mockups unless Architect specifically approves such deviations in writing.
 - 4. Subject to compliance with requirements, approved mockups may become part of completed Work if undisturbed at time of Substantial Completion.

1.7 DELIVERY, STORAGE, AND HANDLING

- A. Store materials not in use in tightly covered containers in well-ventilated areas with ambient temperatures continuously maintained at not less than 45 deg F.
 - 1. Maintain containers in clean condition, free of foreign materials and residue.
 - 2. Remove rags and waste from storage areas daily.

1.8 FIELD CONDITIONS

- A. Apply coatings only when temperature of surfaces to be coated and surrounding air temperatures are between 50 and 95 deg F.
- B. Do not apply coatings when relative humidity exceeds 85 percent; at temperatures less than 5 deg F above the dew point; or to damp or wet surfaces.
- C. Do not apply exterior coatings in snow, rain, fog, or mist.

PART 2 - PRODUCTS

2.1 MANUFACTURERS

- A. Products: Subject to compliance with requirements, available products that may be incorporated into Work are listed in other Part 2 Articles for paint category indicated.

2.2 HIGH-PERFORMANCE COATINGS, GENERAL

- A. MPI Standards: Provide products complying with MPI standards indicated and listed in its "MPI Approved Products Lists."
 - 1. If a manufacturer produces more than one product within an MPI category, provide highest quality product within that category.

- B. Material Compatibility:
 - 1. Provide materials for use within each coating system that are compatible with one another and substrates indicated, under conditions of service and application as demonstrated by manufacturer, based on testing and field experience.
 - 2. For each coat in a coating system, provide products recommended in writing by manufacturers of topcoat for use in coating system and on substrate indicated.
 - 3. Provide products of same manufacturer for each coat in a coating system.
- C. Material Quality: Material containers not displaying coating manufacturer's product identification will not be accepted.
- D. VOC Content: For field applications, verify paints and coatings comply with VOC content limits of authorities having jurisdiction and the following VOC content limits.
 - 1. Flat Paints and Coatings: 50 g/L.
 - 2. Nonflat Paints and Coatings: 50 g/L.
 - 3. Primers, Sealers, and Undercoaters: 100 g/L.
 - 4. Rust-Preventive Coatings: 100 g/L.
 - 5. Zinc-Rich Industrial Maintenance Primers: 100 g/L.
 - 6. Pretreatment Wash Primers: 420 g/L.
 - 7. Floor Coatings: 50 g/L.
 - 8. Shellacs, Clear: 730 g/L.
 - 9. Shellacs, Pigmented: 550 g/L.
- E. Low-Emitting Materials: For field applications that are inside weatherproofing system, verify 90 percent of paints and coatings comply with requirements of California Department of Public Health's "Standard Method for the Testing and Evaluation of Volatile Organic Chemical Emissions from Indoor Sources Using Environmental Chambers."
- F. Colors: See Finish Legend on Drawings for selected paint and coating colors.

2.3 GALVANIZED METAL CLEANERS/ETCHING

- A. Cleaning, Etching, for Steel, Galvanized Metal: MPI #25.
 - 1. Products: Subject to compliance with requirements, provide one of the following:
 - a. Cloverdale Paint: Cloverdale, ClovaClean, 78100.
 - b. Rust-Oleum: Krud Kutter, Metal Clean and Etch, ME326 or ME014.
 - c. Sherwin-Williams: Great Lakes Laboratories, Clean'n Etch, 899.
 - 2. Field-Applied Etching Cleaner: Use in lieu of SSPC-SP 1 Solvent Cleaning, specified under preparation. Not required for shop primed ferrous metal.

2.4 PRIMERS/SEALERS

- A. Primer Sealer, Latex, Interior: MPI #50.
 - 1. Products: Subject to compliance with requirements, provide one Sealers, and Undercoaters of the following:
 - a. Benjamin Moore: Ultra Spec 500, Waterborne Interior Primer Sealer, N534/K534.
 - b. Benjamin Moore: Coronado, Super Kote 5000 Latex Primer-Sealer, 40-41.
 - c. Cloverdale Paint: Premium Classic, Hi-Hide Latex Drywall Sealer, 05250.
 - d. PPG Architectural: Glidden Professional (US), PVA Drywall Interior Primer and Sealer, GPD-0000.
 - e. PPG Architectural: PPG Paints, Speedhide Zero Interior Zero VOC Latex Sealer, 6-4900XI.
 - f. Rodda Paint Co.: Rodda Paint, UL Primer, 503601.
 - g. Sherwin-Williams: ProMar 200 Zero, Interior Latex Primer, B28W02600.

2.5 METAL PRIMERS

- A. Primer, Zinc-Rich, Inorganic, MPI #19.
 - 1. Products: Subject to compliance with requirements, provide one of the following:
 - a. Carboline: Carboline, Carbozinc 11 VOC.
 - b. Cloverdale Paint: Cloverdale, Clovazinc 2 Inorganic Zinc Rich Primer, 83002.
 - c. PPG Architectural: PPG Paints: Metalhide One-Pac Inorganic Zinc Rich Primer, 97-676.
 - d. Rust-Oleum: Rust-Oleum, Rust-O-Zinc Inorganic Zinc Rich Primer, 303976.
 - e. Sherwin-Williams: Protective & Marine, Zinc Clad XI, B69V11/B69D11.
 - f. Approved substitution.
- B. Primer, Zinc-Rich, Inorganic, AESS-19.
 - 1. Products: Subject to compliance with requirements, provide one of the following:
 - a. Tnemec Company Inc.: Tnemec Protective Coatings, Series 90-97 Tneme-Zinc.
- C. Primer, Rust-Inhibitive, Water Based, MPI #107.
 - 1. Products: Subject to compliance with requirements, provide one of the following:
 - a. Benjamin Moore: Ultra Spec HP, Acrylic Metal Primer, HP04/FP04.
 - b. Cloverdale Paint, Cloverdale Paint, Ecologic Water Borne Shop Primer, 7032 Series.
 - c. Sherwin-Williams: Pro Industrial, Pro-Cryl Universal Primer, B66W1310.
- D. Primer, Vinyl Wash, MPI #80.
 - 1. Products: Subject to compliance with requirements, provide one of the following:
 - a. Sherwin-Williams: Product Finishes, Industrial Wash Primer, P60G2/R7K44.
 - b. Approved substitution.

2.6 BLOCK FILLERS

- A. Block Filler, Latex, Interior/Exterior: MPI #4.
 - 1. Products: Subject to compliance with requirements, provide one of the following:
 - a. Benjamin Moore: Coronado, Super Kote 5000 Latex Prod. Block Filler Flat, 958.
 - b. PPG Architectural, PPG, Speedhide Int/ Ext Masonry Hi Fill Latex Block Filler, 6-15XI.
 - c. Rodda Paint Co.: Rodda Paint Co., Sprayable Smooth Block Filler, 501901.
 - d. Sherwin-Williams: PrepRite, Int/Ext Block Filler, B25W00025.
- B. Block Filler, Epoxy, MPI #116.
 - 1. Products: Subject to compliance with requirements, provide one of the following:
 - a. Benjamin Moore: Corotech, Epoxy Mastic Coating, V160.
 - b. Cloverdale Paint: High performance, Epoxy Block Filler, 83065.
 - c. PPG Architectural: Protective and Marine Coatings, Amerlock 400 BF, AK400B x.
 - d. Sherwin-Williams, Protective & Marine, Kem Cati-Coat HS Epoxy Filler/Sealer, B42W00400.

2.7 EPOXY COATINGS

- A. Epoxy, Gloss: MPI #77.
 - 1. Products: Subject to compliance with requirements, provide one of the following:
 - a. Cloverdale Paint: High Performance, ClovaCoat 300 Epoxy High Gloss White, 83300.
 - b. PPG Architectural: PPG, Aquapon 35 Polyamide Epoxy Gloss, 95-1/95-98.
 - c. Sherwin-Williams: Protective & Marine, Tile-Clad HS Epoxy, B62WZ111/B60VZ70.
- B. Epoxy-Modified Latex, Interior, Semi-Gloss (MPI Gloss Level 5), MPI #215.
 - 1. Products: Subject to compliance with requirements, provide one of the following:
 - a. AkzoNobel, Devoe High Performance Coatings, Tru Glaze WB 4426 Water Borne Epoxy, 4426/4420.
 - b. Cloverdale Paint: Cloverdale Paint, Ecologic Waterborne Epoxy Gloss White, 70503A/70503B.

- c. PPG Architectural: Protective and Marine Coatings, Aquapon WB EP Epoxy, Semi-Gloss, 98E-X/98E-100.
 - d. Sherwin-Williams: Pro Industrial, Water Based Catalyzed Epoxy, B73W311/B73V300.
 - C. Epoxy-Modified Latex, Interior, Gloss (MPI Gloss Level 6), MPI #115
 - 1. Products: Subject to compliance with requirements, provide one of the following:
 - a. AkzoNobel, Devoe High Performance Coatings, Tru Glaze WB 4428 Water Borne Epoxy, 4428/4420.
 - b. Cloverdale Paint: Cloverdale Paint, Ecologic Waterborne Epoxy Gloss White, 70503A/70503B.
 - c. PPG Architectural: Protective and Marine Coatings, Aquapon WB EP, 98E-X/98E-98.
 - d. Sherwin-Williams: Pro Industrial, Water Based Catalyzed Epoxy, B73-300 Series.
 - D. Epoxy, Polyamide, High-Build, Low Gloss, MPI #108.
 - 1. Products: Subject to compliance with requirements, provide one of the following:
 - a. AkzoNobel, Devoe High Performance Coatings, Bar Rust 235, 235.
 - b. Benjamin Moore: Corotech, Polyamide Epoxy Semi-Gloss, V400-91.
 - c. Carboline Company: Carboline, Carboguard 60.
 - d. Cloverdale Paint: Cloverdale, ClovaMastic Hi Build Low Temperature Cure Epoxy, 83110.
 - e. Sherwin-Williams: Protective & Marine, Macropoxy 646, Fast Cure Epoxy, B58W00610.
 - E. Epoxy, Polyamide, High-Build, Low Gloss, AESS-108.
 - 1. Products: Subject to compliance with requirements, provide one of the following:
 - a. Tnemec Company Inc.: Tnemec Protective Coatings, Series 27 F.C. Typoxy.
 - b. Approved substitution.
- 2.8 POLYURETHANE COATINGS
- A. Polyurethane, Aliphatic Acrylic, 2-Component, Pigmented, Semi-Gloss (Gloss Level 5), MPI #174.
 - 1. Products: Subject to compliance with requirements, provide one of the following:
 - a. Benjamin Moore: Corotech, Aliphatic Acrylic Urethane Semi-Gloss, V510.
 - b. Carboline Company: Carbothane 133 Series.
 - c. Sherwin-Williams: Protective & Marine, Acrolon 218 HS Polyurethane, B65-650 Series.
 - d. Approved substitution.
 - B. Polyurethane, 2-Component, Pigmented, Gloss (Gloss Level 6), MPI #72.
 - 1. AkzoNobel, Devoe High Performance Coatings, Devthane 379, 379.
 - 2. Benjamin Moore: Corotech, Aliphatic Acrylic Urethane Gloss, V500.
 - 3. Cloverdale Paint: High Performance, Amourshield, 847 Series.
 - 4. Cloverdale Paint: High Performance, Amourshield XP, 837 Series.
 - 5. PPG Architectural: Protective and Marine Coatings, Pitthane Ultra Gloss 95-812 Series, 95-8001/95-819.
 - 6. Sherwin-Williams: Protective & Marine, Acrolon 218 HS Polyurethane, B65-600 Series.
 - C. Polyurethane, Aliphatic Acrylic, 2-Component, Pigmented, Semi-Gloss (Gloss Level 5), AESS-174.
 - 1. Products: Subject to compliance with requirements, provide one of the following:
 - a. Tnemec Company Inc.: Tnemec Protective Coatings, Series 1075 Endura-Shield II.
 - b. Approved substitution.
 - D. Polyurethane, Aliphatic Acrylic, 2-Component, Pigmented, Gloss (Gloss Level 6), AESS-72.
 - 1. Products: Subject to compliance with requirements, provide one of the following:
 - a. Tnemec Company Inc.: Tnemec Protective Coatings, Series 740 UVX, F740.
 - b. Approved substitution.

PART 3 - EXECUTION

3.1 EXAMINATION

- A. Examine substrates and conditions, with Applicator present, for compliance with requirements for maximum moisture content and other conditions affecting performance of the Work.
- B. Maximum Moisture Content of Substrates: When measured with an electronic moisture meter as follows:
 - 1. Concrete: 12 percent.
 - 2. Fiber-Cement Board: 12 percent.
 - 3. Masonry (Clay and CMUs): 12 percent.
 - 4. Gypsum Board: 12 percent.
- C. Gypsum Board Substrates: Verify that finishing compound is sanded smooth.
- D. [Plaster Substrates: Verify that plaster is fully cured.]
- E. Verify suitability of substrates, including surface conditions and compatibility, with existing finishes and primers.
- F. Proceed with coating application only after unsatisfactory conditions have been corrected.
 - 1. Application of coating indicates acceptance of surfaces and conditions.

3.2 PREPARATION

- A. Comply with manufacturer's written instructions and recommendations in "MPI Architectural Painting Specification Manual" applicable to substrates and coating systems indicated.
- B. Remove hardware, covers, plates, and similar items already in place that are removable and are not to be painted.
 - 1. If removal is impractical or impossible because of size or weight of item, provide surface-applied protection before surface preparation and painting.
 - 2. After completing painting operations, use workers skilled in the trades involved to reinstall items that were removed. Remove surface-applied protection if any.
- C. Clean substrates of substances that could impair bond of coatings, including dust, dirt, oil, grease, and incompatible paints and encapsulants.
 - 1. Remove incompatible primers and reprime substrate with compatible primers or apply tie coat as required to produce coating systems indicated.
- D. Concrete Substrates: Remove release agents, curing compounds, efflorescence, and chalk. Do not coat surfaces if moisture content or alkalinity of surfaces to be coated exceeds that permitted in manufacturer's written instructions.
- E. Masonry Substrates: Remove efflorescence and chalk. Do not coat surfaces if moisture content, alkalinity of surfaces, or alkalinity of mortar joints exceeds that permitted in manufacturer's written instructions.
 - 1. Clean surfaces with pressurized water. Use pressure range of **[100 to 600 psi] [1,500 to 4,000 psi]** at 6 to 12 inches.
- F. Steel Substrates: Remove rust, loose mill scale, and shop primer if any. Clean using methods recommended in writing by paint manufacturer but not less than the following:
 - 1. SSPC-SP 6/NACE No. 3.
- G. Shop-Primed Steel Substrates: Clean field welds, bolted connections, and areas where shop paint is abraded. Paint exposed areas with the same material as used for shop priming to comply with SSPC-PA 1 for touching up shop-primed surfaces.

- H. Galvanized-Metal Substrates: Remove grease and oil residue from galvanized sheet metal by mechanical methods to produce clean, lightly etched surfaces that promote adhesion of subsequently applied coatings.
- I. Aluminum Substrates: Remove loose surface oxidation.

3.3 APPLICATION

- A. Apply high-performance coatings according to manufacturer's written instructions and recommendations in "MPI Architectural Painting Specification Manual."
 - 1. Use applicators and techniques suited for coating and substrate indicated.
 - 2. Coat surfaces behind movable equipment and furniture same as similar exposed surfaces. Before final installation, coat surfaces behind permanently fixed equipment or furniture with prime coat only.
 - 3. Coat backsides of access panels, removable or hinged covers, and similar hinged items to match exposed surfaces.
 - 4. Do not apply coatings over labels of independent testing agencies or equipment name, identification, performance rating, or nomenclature plates.
- B. Tint each undercoat a lighter shade to facilitate identification of each coat if multiple coats of same material are to be applied. Tint undercoats to match color of finish coat, but provide sufficient difference in shade of undercoats to distinguish each separate coat.
- C. If undercoats or other conditions show through final coat, apply additional coats until cured film has a uniform coating finish, color, and appearance.
- D. Apply coatings to produce surface films without cloudiness, spotting, holidays, laps, brush marks, runs, sags, ropiness, or other surface imperfections. Produce sharp glass lines and color breaks.

3.4 FIELD QUALITY CONTROL

- A. Dry Film Thickness Testing: Owner may engage the services of a qualified testing and inspecting agency to inspect and test coatings for dry film thickness.
 - 1. Contractor shall touch up and restore coated surfaces damaged by testing.
 - 2. If test results show that dry film thickness of applied coating does not comply with coating manufacturer's written recommendations, Contractor shall pay for testing and apply additional coats as needed to provide dry film thickness that complies with coating manufacturer's written recommendations.

3.5 CLEANING

- A. At end of each workday, remove rubbish, empty cans, rags, and other discarded materials from Project site.
- B. After completing coating application, clean spattered surfaces. Remove spattered coatings by washing, scraping, or other methods. Do not scratch or damage adjacent finished surfaces.

3.6 PROTECTION

- A. Protect Work of other trades against damage from coating operation. Correct damage to Work of other trades by cleaning, repairing, replacing, and recoating, as approved by Architect, and leave in an undamaged condition.
- B. At completion of construction activities of other trades, touch up and restore damaged or defaced coated surfaces.

3.7 HIGH-PERFORMANCE COATING SCHEDULE

A. CMU Substrates:

1. Epoxy-Modified Latex System:
 - a. Block Filler: Block filler, epoxy, MPI #116.
 - b. Intermediate Coat: Epoxy-modified latex, interior, matching topcoat.
 - c. Topcoat: Epoxy-modified latex (MPI Gloss Level 5), MPI #215.
 - d. Topcoat: Epoxy-modified latex (MPI Gloss Level 6), MPI #115.
 - e. Application:
 - 1) Interior wet locations and exterior locations.
2. Epoxy-Modified Latex System:
 - a. Block Filler: Block filler, latex, interior/exterior, MPI #4.
 - b. Intermediate Coat: Epoxy-modified latex, interior, matching topcoat.
 - c. Topcoat: Epoxy-modified latex (MPI Gloss Level 5), MPI #215.
 - d. Topcoat: Epoxy-modified latex (MPI Gloss Level 6), MPI #115.
 - e. Application:
 - 1) Interior dry locations.

B. Structural Steel and Metal Fabrications:

1. Pigmented Polyurethane over Inorganic Zinc-Rich Primer and High-Build Epoxy System:
 - a. Prime Coat: Primer, zinc-rich, inorganic, MPI #19.
 - b. Intermediate Coat: Epoxy, high build, low gloss, MPI #108.
 - c. Topcoat: Polyurethane, 2 component, pigmented (Gloss Level 6), MPI #72.
 - d. Applications:
 - 1) Exterior hollow metal doors and frames, bollards, trash enclosure framing, stairs, ladders, handrails, guard rails, and other ferrous metals not designated as AESS.
2. Epoxy-Modified Latex System:
 - a. Prime Coat: Primer, rust inhibitive, water based, MPI #107.
 - b. Intermediate Coat: Epoxy-modified latex, interior, matching topcoat.
 - c. Topcoat: Epoxy-modified latex (MPI Gloss Level 5), MPI #215.
 - d. Topcoat: Epoxy-modified latex (MPI Gloss Level 6), MPI #115.
 - e. Applications:
 - 1) Interior hollow metal doors and frames, stairs, ladders, handrails, guard rails, and other ferrous metals that are not designated as AESS.

C. Galvanized-Metal Substrates:

1. Pigmented Polyurethane System:
 - a. Prime Coat: Primer, vinyl wash, MPI #80.
 - b. Intermediate Coat: Polyurethane, 2 component, pigmented, matching topcoat.
 - c. Topcoat: Polyurethane (Gloss Level 5), MPI #174.

END OF SECTION 099600

SECTION 099623
GRAFFITI-RESISTANT COATINGS

PART 1 - GENERAL

1.1 SUMMARY

- A. Section Includes:
1. Non-sacrificial, low-VOC, anti-graffiti coating.

1.2 ADMINISTRATIVE REQUIREMENTS

- A. Preinstallation Meetings: Conduct meeting at Project site.
1. Require attendance of parties directly affecting Work of this Section, including Contractor, Owner's Representative, applicator, and manufacturer's representative.
 2. Review environmental regulations, test panel procedures, protection of surrounding areas and non-masonry surfaces, surface preparation, application, field quality control, final cleaning, and coordination with other Work

1.3 ACTION SUBMITTALS

- A. Product Data: Manufacturer's specifications and technical data including performance, construction and fabrication.
1. Manufacturer's application instructions including surface preparation.
- B. Sustainable Design Submittals:
1. Environmental Product Declaration (EPD): For each product.
 2. Health Product Declaration (HPD): For each product.
 3. Product Data: For coatings, indicating VOC content.
 4. Laboratory Test Reports: For coatings, indicating compliance with requirements for low-emitting materials.
- C. Samples: Obtain 2 liquid Samples of specified anti-graffiti for Sample application.
1. Sample Size: 12 inch square.
 2. Submit manufacturer's sample custom color match of Architects color sample.

1.4 INFORMATIONAL SUBMITTALS

- A. Applicator Qualifications: Submit certification stating compliance with Quality Assurance Article.
1. Provide list of 5 most recently completed projects where specified material was used. Include project names, locations, architects, and methods of application.
- B. Environmental Regulations: Submit certification stating coating to be applied is in compliance with federal environmental Volatile Organic Compounds (VOC) regulations.

1.5 QUALITY ASSURANCE

- A. Manufacturer's Qualifications: Not less than 5 years of experience in actual production of specified products.
- B. Installer's Qualifications: Firm trained and certified by coating manufacturer, with not less than 5 years of experience installing systems similar in complexity to those required for this Project, including specific requirements indicated.

- C. Mockups: Build mockups in compliance with Section 014339 – Mockups to verify selections made under Sample submittals, to demonstrate aesthetic effects, and to set quality standards for materials and execution.
 - 1. Build mockups approximately 6 ft. by 6 ft. for each type of coating and each type of substrate indicated or, if not indicated, build mockups where directed by Architect.
 - a. Proposed Substitutions: If product substitution is proposed, build additional mockups for side-by-side comparisons between specified product and proposed substitution.
 - 2. Apply graffiti-resistant coating to test surfaces according to coating manufacturer's instructions. Allow coating to cure properly, apply graffiti as directed by Owner or Architect, then remove graffiti.
 - 3. Acceptable Work: Coating will be deemed acceptable if cleaned surface is undamaged and shows no graffiti "ghosts" or "shadows" that would indicate an incomplete graffiti removal.
 - 4. Obtain Architect's approval of mockups before start of final unit of Work.
 - 5. Approval of mockups does not constitute approval of deviations from Contract Documents contained in mockups unless Architect specifically approves such deviations in writing.
 - 6. Retain and maintain mockups during construction in undisturbed condition as a standard for judging completed Work.
 - 7. Subject to compliance with requirements, approved mockups may become part of completed Work if undisturbed at time of Substantial Completion.

1.6 DELIVERY, STORAGE, AND HANDLING

- A. Deliver materials to site In manufacturers original, unopened containers and packaging, bearing manufacturer's name label with the following information:
 - 1. Name of material.
 - 2. Manufacturer's stock number and date of manufacture.
 - 3. Manufacturer's name.
 - 4. Contents by volume for major pigment and vehicle constituents.
 - 5. Application Instructions.
 - 6. Color name and number (if applicable)
- B. Store materials not in use in tightly covered containers. Maintain containers used in storage of coating materials in a clean condition, free of foreign materials and residue.
- C. Protect materials from freezing where necessary. Keep storage area neat and orderly. Remove flammable rags and waste daily. Take precautions to ensure that workers and Work areas are adequately protected from fire hazards and health hazards resulting from handling, mixing, and application of coatings.

1.7 FIELD CONDITIONS

- A. Comply with manufacturer's recommendations regarding environmental conditions under which materials can be stored and applied.
- B. Environmental Requirements:
 - 1. Maintain air and substrate temperature between 40 degs F or below 100 degs F unless otherwise specified by manufacturer.
 - 2. Do not proceed with application if substrate is wet or contains frozen water.
 - 3. Do not apply material when rain is predicted within 24 hours; or earlier than 5 days after substrate became wet.
 - 4. Do not apply materials in high or gusty winds.

1.8 WARRANTY

- A. Special Warranty: Manufacturer agrees to repair or replace graffiti-resistant coatings that fail within specified warranty period.
 - 1. Retreat defective areas by system manufacture as determined by Architect.
 - 2. Manufacturer shall be responsible for providing labor and material to reseal areas where coating effectiveness does not meet specified limits.
 - 3. Warranty Period: 5 years from date of Substantial Completion.

1.9 MAINTENANCE

- A. Extra Materials:
 - 1. Provide extra graffiti stripper material in quantities described below. Package with protective covering for storage and identify with labels describing contents. Deliver extra materials to Owner.
 - a. Graffiti Removal Quantity: 1 gallon per 2,500 square feet ounce of covered area.
 - b. Removal Agent: Packaged in 16 to 32 ounce bottles and boxed for storage.

PART 2 - PRODUCTS

2.1 MANUFACTURERS

- A. Single Source Responsibility: Provide water repellent/anti-graffiti coatings by one manufacturer.

2.2 PERFORMANCE CRITERIA

- A. Regulatory Requirements: Products shall comply with State and local regulations regarding Volatile Organic Content (VOC).

2.3 MATERIALS

- A. Water Repellent and Graffiti-Resistant Type-1: Clear, solvent-based, silicone elastomer, water and graffiti resistant coating.
 - 1. Products: Subject to compliance with requirements, provide one of the following:
 - a. Professional Products of Kansas, Inc.: PWS-15.
 - b. ProSoCo, Inc.: Sure Klean Weather Seal Blok-Guard & Graffiti Control Ultra 15.
 - c. TK Products Construction Coatings: TK-Block and Graffiti Guard 5220 VOC.
 - d. Tnemec Inc.: Series V626 Dura A Pell GS.
 - e. Approved substitution.
 - 2. Performance Requirements:
 - a. VOC Content: 350 g/L or less.
 - b. Solids: Maximum 15 percent.
 - c. Surface Appearance: No appreciable difference compared to non-coated surface.
 - d. Excellent ultraviolet light stability.
 - e. Cleanability: Level 3 when tested according to ASTM D6578.
 - 3. Applications: Standard concrete masonry units (CMU) and split-faced CMU.
- B. Graffiti Removal Product: Product approved or recommended by graffiti-resistant coating manufacturer and containing benzyl alcohol, designed to remove graffiti from anti-graffiti coating.
 - 1. Products: Subject to compliance with requirements, provide one of the following:
 - a. Franmar: Blue Bear 680HS Hard Surface Graffiti Remover.
 - b. ProSoCo, Inc.: Defaser Eraser.
 - c. Rust-Oleum: Krud Kutter Graffiti Remover.
 - d. Approved substitution.

PART 3 - - EXECUTION

3.1 EXAMINATION

- A. Verification of Conditions: Examine areas and conditions under which Work is to be performed and identify conditions detrimental to proper or timely completion.
 - 1. Surface to be treated is clean, dry and contains no frozen water.
 - 2. Environmental conditions are appropriate for application.
 - 3. Do not proceed until unsatisfactory conditions have been corrected.

3.2 PREPARATION

- A. Surface Preparation: Ensure surfaces are free of cracks, dirt, oils, paint, or other contaminants that may affect appearance or performance of water repellent material.
- B. Protection:
 - 1. Protect shrubs, metal, wood trim, glass, asphalt, and other building hardware during application from over-spray.
 - 2. Do not permit spray mist or liquid to drift onto surrounding properties.
- C. Surface Preparation: Clean surfaces of dust, dirt, oil, grease, laitance, and other surface contaminants that adversely affect adhesion and appearance. Clean other surfaces by mid-pressure water (1,500 psi) and commercial paint strippers. Pressure washing is minimum cleaning that will be accepted. Other methods, such as blastracking, mobile power scrubbing, and sandblasting, may be submitted.
- D. Remove dirt, dust, and materials that will interfere with proper and effective application of anti-graffiti coating. It is responsibility of Contractor to prepare surfaces as recommended by anti-graffiti coating manufacturer and acceptable to Architect.
- E. Check compatibility of installed sealants and patching materials to be used with anti-graffiti coating.

3.3 APPLICATION

- A. Comply with manufacturer's recommendations applying at rates indicated on container label.
- B. Apply at temperature and weather conditions recommended the manufacture as specified.
- C. Thoroughly brush out surface residue until material completely penetrates into surface.
- D. Protect treated areas from rain and other surface water for a period of not less than 4 hours after application.
- E. Provide adequate ventilation and follow governmental safety regulations.

3.4 REPAIR

- A. Correct Work that does not conform to specified requirements or replace as directed by Owner at no additional cost or extension of time to Owner.

3.5 CLEANING

- A. Remove protective coverings from adjacent surfaces and other protected areas.
- B. Immediately clean over-sprayed coating from adjoining surfaces and surfaces soiled by sacrificial graffiti coating application as work progresses.
- C. At completion, remove from site excess material, debris, and waste resulting from this Work. Dispose of water repellent containers per state and local environmental regulations.

3.6 CLOSEOUT ACTIVITIES

- A. Demonstration: Manufacturer's representative shall provide demonstration of cleaning procedure to Owner after completion of application and surface has properly cured. Coordinate demonstration meeting with Owner and Owner's personnel.

END OF SECTION 099623

SECTION 101423
PANEL SIGNAGE

PART 1 - GENERAL

1.1 SUMMARY

- A. Section Includes:
1. Rigid panel signs.

1.2 ACTION SUBMITTALS

- A. Product Data: For each type of product.
- B. Sustainable Design Submittals:
1. Laboratory Test Reports: For adhesives, indicating compliance with requirements for low-emitting materials.
 2. Product Data: For installation adhesives, indicating VOC content.
 3. Laboratory Test Reports: For installation adhesives, indicating compliance with requirements for low-emitting materials.
- C. Shop Drawings: For panel signs.
1. Include fabrication and installation details and attachments to other Work.
 2. Show sign mounting heights, locations of supplementary supports to be provided by other installers, and accessories.
 3. Show message list, typestyles, graphic elements, and layout for each sign in size acceptable to Architect.
- D. Samples for Verification: For each type of sign assembly showing components and required finishes in manufacturer's standard size unless otherwise indicated and as follows:
1. Panel Signs: Not less than 12 inches square, including corner.
 2. Variable Component Materials: Minimum 8 inch Sample of each base material, character (letter, number, and graphic element) in each exposed color and finish not included in Samples above.
 3. Exposed Accessories: Full-size Sample of each accessory type.
 4. Full-size Samples, if approved, will be returned to Contractor for use in Project.
- E. Product Schedule: For panel signs. Use same designations indicated on Drawings or as specified.

1.3 INFORMATIONAL SUBMITTALS

- A. Qualification Data: For Installer and fabricator.
- B. Sample Warranty: For special warranty.

1.4 CLOSEOUT SUBMITTALS

- A. Maintenance Data: For signs to include in maintenance manuals.

1.5 QUALITY ASSURANCE

- A. Fabricator Qualifications: Company specializing in fabricating specified types of signage with a minimum 3 years of experience of comparable scale and scope as this Project.

1.6 FIELD CONDITIONS

- A. Environmental Limitations: Do not deliver or install panel signage until spaces are enclosed and weathertight, wet Work in spaces is complete and dry, and temporary HVAC system is operating and maintaining ambient temperature and humidity conditions at occupancy levels during remainder of construction period.
- B. Field Measurements: Verify locations of anchorage devices embedded in permanent construction by other installers by field measurements before fabrication, and indicate measurements on Shop Drawings.

1.7 WARRANTY

- A. Special Warranty: Manufacturer agrees to repair or replace components of signs that fail in materials or workmanship within specified warranty period.
 - 1. Failures include the following:
 - a. Deterioration of finishes beyond normal weathering.
 - b. Deterioration of embedded graphic image.
 - c. Separation or delamination of sheet materials and components.
 - 2. Warranty Period: 5 years from date of Substantial Completion.

PART 2 - PRODUCTS

2.1 MANUFACTURER

- A. Fabricators: Subject to compliance with requirements, provide products from one of the following:
 - 1. Rainier Industries.
 - 2. Trade-Marx Sign & Display.
 - 3. Tube Art Group.
 - 4. United Print Sign Graphics.
 - 5. Vertical Visual Solutions.
 - 6. Northwest Sign and Design.
 - 7. Approved substitution.

2.2 PERFORMANCE CRITERIA

- A. Structural Performance: Signs and supporting elements shall withstand effects of gravity and other loads within limits and under conditions indicated.
 - 1. Uniform and concentrated loads need not be assumed to act concurrently.
- B. Thermal Movements: For exterior signs, allow for thermal movements from ambient and surface temperature changes.
 - 1. Temperature Change: 120 deg F, ambient; 180 deg F, material surfaces.

2.3 PANEL SIGNS

- A. Panel Signs, General: Signs with smooth, uniform surfaces; with message and characters having uniform faces, sharp corners, and precisely formed lines and profiles; and as indicated below.
 - 1. Solid-Sheet Signs: Signs fabricated from sheet material indicated below, with finish specified in "Surface Finish and Applied Graphics" Subparagraph.
 - 2. Flatness Tolerance: Sign shall remain flat or uniformly curved under installed conditions as indicated on Drawings and within a tolerance of plus or minus 1/16 inch measured diagonally from corner to corner.
 - 3. Thickness: 0.25 inch.
 - 4. Material: Non glare, cast acrylic sheet.

5. Graphics: Applied vinyl film.
 - a. Surface: Apply graphics to 2nd surface.
6. Translucence: Transparent.
7. Color: As selected by Architect from manufacturers color range.
8. Edges: Square-cut and finished with no visible saw marks.
9. Mounting: Surface mounted to wall with 2-face tape and sealant.

2.4 PANEL-SIGN MATERIALS

- A. Acrylic Sheet: ASTM D4802; 1/16 inch thick, clear, non-glare, Type UVF; category as standard with manufacturer for each sign.
- B. Vinyl Film: UV-resistant, non-yellowing vinyl film of nominal thickness indicated, with pressure-sensitive, permanent adhesive and release liner on back; suitable for exterior applications where scheduled.
 1. Film for Printed Graphics:
 - a. Products: Subject to compliance with requirements, provide one of the following:
 - 1) Avery Dennison: MPI 2600 Series.
 - 2) Orafol: Oracal 600 Series.
 - 3) 3M: IJ35 Series.
 - 4) Approved substitution.
 - b. Film Thickness: Minimum of 3.2 mils.
- C. Paints and Coatings for Sheet Materials: Inks, dyes, and paints that are recommended by manufacturer for optimum adherence to surface and are UV and water resistant for colors and exposure indicated.
 1. Manufacturers: Subject to compliance with requirements, provide products by the following:
 - a. Matthews Paint; A Subsidiary of PPG.
 - b. Approved substitution.

2.5 ACCESSORIES

- A. 2-Face Tape: Manufacturer's standard high-bond, foam-core tape, 0.045 inch thick, with adhesive on both sides.

2.6 FABRICATION

- A. General: Provide manufacturer's standard sign assemblies according to requirements indicated.
 1. Preassemble signs in shop to greatest extent possible. Disassemble signs and assemblies only as necessary for shipping and handling limitations. Clearly mark units for reassembly and installation; apply markings in locations concealed from view after final assembly.
 2. Mill joints to a tight, hairline fit. Form assemblies and joints exposed to weather to resist water penetration and retention.
 3. Conceal connections if possible; otherwise, locate connections where they are inconspicuous.
 4. Provide rabbets, lugs, and tabs necessary to assemble components and to attach to existing work. Drill and tap for required fasteners. Use concealed fasteners where possible; use exposed fasteners that match sign finish.
- B. Subsurface-Applied Graphics: Apply graphics to second surface of clear face-sheet material to produce precisely formed image. Image shall be free of rough edges.
- C. Shop- and Subsurface-Applied Vinyl: Align vinyl film in final position and apply to surface. Firmly press film from middle outward or as recommended by film manufacturer to obtain good bond without blisters or fishmouths.

2.7 GENERAL FINISH REQUIREMENTS

- A. Protect mechanical finishes on exposed surfaces from damage by applying a strippable, temporary protective covering before shipping.
- B. Appearance of Finished Work: Noticeable variations in same piece are not acceptable. Variations in appearance of adjoining components are acceptable if they are within range of approved Samples and are assembled or installed to minimize contrast.

PART 3 - EXECUTION

3.1 EXAMINATION

- A. Examine substrates, areas, and conditions, with Installer present, for compliance with requirements for installation tolerances and other conditions affecting performance of Work.
- B. Verify that sign-support surfaces are within tolerances to accommodate signs without gaps or irregularities between backs of signs and support surfaces unless otherwise indicated.
- C. Verify that anchorage devices embedded in permanent construction are correctly sized and located to accommodate signs.
- D. Proceed with installation only after unsatisfactory conditions have been corrected.

3.2 INSTALLATION

- A. General: Install signs using mounting methods indicated and according to manufacturer's written instructions.
 - 1. Install signs level, plumb, true to line, and at locations and heights indicated, with sign surfaces free of distortion and other defects in appearance.
 - 2. Install signs so they do not protrude or obstruct according to accessibility standard.
 - 3. Before installation, verify that sign surfaces are clean and free of materials or debris that would impair installation.
 - 4. Corrosion Protection: Coat concealed surfaces of exterior aluminum in contact with grout, concrete, masonry, wood, or dissimilar metals, with a heavy coat of bituminous paint.
- B. Mounting Methods:
 - 1. 2-Face Tape: Clean bond-breaking materials from substrate surface and remove loose debris. Apply tape strips symmetrically to back of sign and of suitable quantity to support weight of sign without slippage. Keep strips away from edges to prevent visibility at sign edges. Place sign in position, and push to engage tape adhesive.

3.3 ADJUSTING

- A. Remove and replace damaged or deformed signs and signs that do not comply with specified requirements. Replace signs with damaged or deteriorated finishes or components that cannot be successfully repaired by finish touchup or similar minor repair procedures.

3.4 CLEANING

- A. Remove temporary protective coverings and strippable films as signs are installed.
- B. On completion of installation, clean exposed surfaces of signs according to manufacturer's written instructions, and touch up minor nicks and abrasions in finish. Maintain signs in a clean condition during construction and protect from damage until acceptance by Owner.

END OF SECTION 101423

SECTION 101423.16
ROOM-IDENTIFICATION PANEL SIGNAGE

PART 1 - GENERAL

1.1 SUMMARY

- A. Section Includes:
 - 1. Room-identification signs.

1.2 ACTION SUBMITTALS

- A. Product Data: For each type of product.
- B. Sustainable Design Submittals:
 - 1. Product Data: For adhesives, indicating VOC content.
 - 2. Laboratory Test Reports: For adhesives, indicating compliance with requirements for low-emitting materials.
- C. Shop Drawings: For room-identification signs.
 - 1. Include fabrication and installation details and attachments to other Work.
 - 2. Show sign mounting heights and accessories.
 - 3. Show message list, typestyles, graphic elements, including raised characters and Braille, and layout for each sign at least 1/2 size.
- D. Samples for Verification: For each type of sign assembly showing components and required finishes, in manufacturer's standard size unless otherwise indicated and as follows:
 - 1. Room-Identification Signs: Full-size Sample.
 - 2. Variable Component Materials: 8 inch Sample of each base material, character (letter, number, and graphic element) in each exposed color and finish not included in Samples above.
 - 3. Exposed Accessories: Full-size Sample of each accessory type.
 - 4. Full-size Samples, if approved, will be returned to Contractor for use in Project.
- E. Product Schedule: For room-identification signs. Use same designations indicated on Signage Detail Sheet.

1.3 INFORMATIONAL SUBMITTALS

- A. Qualification Data: For Installer and fabricator.
- B. Sample Warranty: For special warranty.

1.4 CLOSEOUT SUBMITTALS

- A. Furnish extra materials, from same product run, that match products installed and that are packaged with protective covering for storage and identified with labels describing contents.

1.5 QUALITY ASSURANCE

- A. Fabricator Qualifications: Company specializing in fabricating specified types of signage with a minimum 3 years of experience of comparable scale and scope as this Project.

1.6 FIELD CONDITIONS

- A. Ambient Conditions: Do not deliver or install room identification signage until spaces are enclosed and weathertight, wet Work in spaces is complete and dry, and temporary HVAC system is operating and maintaining ambient temperature and humidity conditions at occupancy levels during remainder of construction period.

1.7 WARRANTY

- A. Special Warranty: Manufacturer agrees to repair or replace components of signs that fail in materials or workmanship within specified warranty period.
 - 1. Failures include the following:
 - a. Deterioration of finishes beyond normal weathering.
 - b. Separation or delamination of sheet materials and components.
 - 2. Warranty Period: 5 years from date of Substantial Completion.

PART 2 - PRODUCTS

2.1 MANUFACTURER

- A. Fabricators: Subject to compliance with requirements, provide products from one of the following:
 - 1. Best Sign Systems Inc.
 - 2. Center Pointe Signs.
 - 3. Neiman & Company Architectural Signage.
 - 4. Signtech
 - 5. Trade-Marx Sign & Display.
 - 6. Tube Art Group.
 - 7. Vertical Visual Solutions.
 - 8. Approved substitution.

2.2 PERFORMANCE CRITERIA

- A. Accessibility Standard: Comply with applicable provisions in the USDOJ's "2010 ADA Standards for Accessible Design" and ICC A117.1.

2.3 ROOM-IDENTIFICATION SIGNS

- A. Room-Identification Signage, General: Smooth, uniform surfaces; with messages and characters having uniform faces, sharp corners, and precisely formed lines and profiles.
 - 1. Laminated photopolymers, added-on characters, and engraved characters are not acceptable.
- B. Interior Signs:
 - 1. Composition: Moisture-resistant, non-glare, interior nylon, photopolymer on ultraviolet-resistant, clear PETG sign base, single piece construction.
 - 2. Raised-Copy Thickness: 1/32 inch.
 - 3. PETG-Sheet Thickness: 0.118 inch.
 - 4. Composite Sheet Thickness: 0.15 inch.
 - 5. Sizes: As indicated on Drawings.
 - 6. Color: Matthews Paint10269 Dark Slate.
 - 7. Surface Graphics: Applied photopolymer.
 - 8. Subsurface Graphics: Slide-in changeable insert.
 - 9. Sign Panel Perimeter:
 - a. Edge Conditions: Square cut, with smooth edges.
 - b. Corner Condition in Elevation: 1/16 inch radius.

10. Text and Pictographs:
 - a. Type: Hot stamped.
 - b. Foil Color: White.
 - c. Typeface: Arial unless indicated otherwise.
 - d. Letter Height: As indicated on Drawings.
11. Mounting: 2-face tape.

C. Tactile and Braille:

1. Precisely form raised characters and Grade 2 Braille free from burrs and cut marks.
2. Grade 2 Braille Copy: Coordinate messages in conjunction as indicated. Braille copy indicated on Drawings is for size and position only. Do not use for full message.
 - a. Applied applique and bead Braille are not acceptable.

2.4 SIGN MATERIALS

- A. Acrylic Sheet: ASTM D4802; 1/16 inch thick, clear, non-glare, Type UVF; category as standard with manufacturer for each sign.
 1. Provide for signs indicated to have changeable message window.
- B. Modified Polyethelene Terephtalate Glycol (PETG): ASTM D5047, glycol-modified polyethylene terephtalate copolyester that is a clear amorphous thermoplastic.
- C. Nylon Photopolymer Film: Laminated, clear, polymer film that reacts to UV light forming a hard surface.
 1. Hardness: Shore D Hardness of 80 minimum after 14 day cure at 70 deg F.
- D. Vinyl Film: UV-resistant vinyl film with pressure-sensitive, permanent adhesive; die cut to form characters or images as indicated on Drawings[**and suitable for exterior applications**].

2.5 ACCESSORIES

- A. Interior Sign Mounting:
 1. 2-Face Tape: Manufacturer's standard high-bond, foam-core tape, 0.045 inch thick, with adhesive on both sides.

2.6 FABRICATION

- A. General: Provide manufacturer's standard sign assemblies according to requirements indicated.
 1. Preassemble signs and assemblies in shop to greatest extent possible. Disassemble signs and assemblies only as necessary for shipping and handling limitations. Clearly mark units for reassembly and installation; apply markings in locations concealed from view after final assembly.
 2. Mill joints to a tight, hairline fit. Form assemblies and joints exposed to weather to resist water penetration and retention.

2.7 GENERAL FINISH REQUIREMENTS

- A. Protect finishes on exposed surfaces from damage by applying a strippable, temporary protective covering before shipping.
- B. Appearance of Finished Work: Noticeable variations in same piece are not acceptable. Variations in appearance of adjoining components are acceptable if they are within range of approved Samples and are assembled or installed to minimize contrast.

PART 3 - EXECUTION

3.1 EXAMINATION

- A. Examine substrates, areas, and conditions, with Installer present, for compliance with requirements for installation tolerances and other conditions affecting performance of Work.
- B. Verify that sign-substrates are within tolerances to accommodate signs without gaps or irregularities between backs of signs and support surfaces unless otherwise indicated.
- C. Proceed with installation only after unsatisfactory conditions have been corrected.

3.2 INSTALLATION

- A. General: Install signs using mounting methods indicated and according to manufacturer's written instructions.
 - 1. Install signs level, plumb, true to line, and at locations and heights indicated, with sign surfaces free of distortion and other defects in appearance.
 - 2. Install signs so they do not protrude or obstruct according to accessibility standard.
 - 3. Before installation, verify that sign surfaces are clean and free of materials or debris that would impair installation.
- B. Accessibility: Install signs in locations on walls as indicated on Drawings and according to accessibility standard.
- C. Mounting Methods:
 - 1. 2-Face Tape: Clean bond-breaking materials from substrate surface and remove loose debris. Apply tape strips symmetrically to back of sign and of suitable quantity to support weight of sign without slippage. Place strips a minimum of 1/4 inch away from sign edge to prevent visibility at sign edges. Place sign in position, and push to engage tape adhesive.
 - a. Application: Interior signage.

3.3 ADJUSTING

- A. Remove and replace damaged or deformed signs and signs that do not comply with specified requirements. Replace signs with damaged or deteriorated finishes or components that cannot be successfully repaired by finish touchup or similar minor repair procedures.

3.4 CLEANING

- A. Remove temporary protective coverings and strippable films as signs are installed.
- B. On completion of installation, clean exposed surfaces of signs according to manufacturer's written instructions, and touch up minor nicks and abrasions in finish. Maintain signs in a clean condition during construction and protect from damage until acceptance by Owner.

END OF SECTION 101423.16

SECTION 102239
FOLDING PANEL PARTITIONS

PART 1 - GENERAL

1.1 SUMMARY

- A. Section Includes:
 - 1. Manually operated, acoustical panel partitions.

1.2 ADMINISTRATIVE REQUIREMENTS

- A. Preinstallation Meetings: Conduct meeting at Project site.

1.3 ACTION SUBMITTALS

- A. Product Data: For each type of product.
- B. Shop Drawings: For operable panel partitions.
 - 1. Include plans, elevations, sections, attachment details, and numbered panel installation sequence.
 - 2. Indicate stacking and operating clearances. Indicate location and installation requirements for hardware and track, blocking, and direction of travel.
- C. Samples for Verification: For each type of exposed material, finish, covering, or facing, prepared on Samples of size indicated below:
 - 1. Textile Facing Material: Full width by not less than 36 inch long section of facing material from dye lot to be used for Work, with specified treatments applied. Show complete pattern repeat.
 - 2. Panel Edge Material: Not less than 3 inches long.
 - 3. Hardware: 1 of each exposed door-operating device.

1.4 INFORMATIONAL SUBMITTALS

- A. Qualification Data: For Installer.
- B. Seismic Qualification Certificates: For operable panel partitions, tracks, accessories, and components, from manufacturer. Include seismic capacity of partition assemblies to remain in vertical position during a seismic event and the following:
 - 1. Basis for Certification: Indicate whether certification is based on analysis, testing, or experience data, according to ASCE 7.
 - 2. Detailed description of partition anchorage devices on which certification is based and their installation requirements.
- C. Product Certificates: For each type of operable panel partition.
- D. Product Test Reports: For each operable panel partition, for tests performed by a qualified testing agency.
- E. Sample Warranty: For special warranty.

1.5 CLOSEOUT SUBMITTALS

- A. Operation and Maintenance Data: For operable panel partitions to include in maintenance manuals.
 - 1. In addition to items specified in Section 017823 – Operation and Maintenance Data, include the following:
 - a. Panel finish facings and finishes for exposed trim and accessories. Include precautions for cleaning materials and methods that could be detrimental to finishes and performance.
 - b. Seals, hardware, track, track switches, carriers, and other operating components.

1.6 MAINTENANCE MATERIAL SUBMITTALS

- A. Furnish extra materials, from same production run, that match products installed and that are packaged with protective covering for storage and identified with labels describing contents.
 - 1. Panel Finish-Facing Material: Furnish full width in quantity to cover both sides of 2 panels when installed.

1.7 QUALITY ASSURANCE

- A. Manufacturer Qualifications: Company specializing in manufacturing products specified in this Section with minimum of 3 years of documented experience.
 - 1. Able to document 3 recent sound tests where specified NIC performance requirements were achieved. Include names and telephone numbers of contact names.
 - 2. Maintains locally available parts, servicing, and technical assistance.
- B. Installer Qualifications: An entity that employs installers and supervisors who are trained and approved by manufacturer with minimum of 3 years of documented experience.

1.8 DELIVERY, STORAGE, AND HANDLING

- A. Protectively package and sequence panels in order for installation. Clearly mark packages and panels with numbering system used on Shop Drawings. Do not use permanent markings on panels.

1.9 WARRANTY

- A. Special Warranty: Manufacturer agrees to repair or replace components of operable panel partitions that fail in materials or workmanship within specified warranty period.
 - 1. Failures include the following:
 - a. Faulty operation of operable panel partitions.
 - b. Deterioration of metals, metal finishes, and other materials beyond normal use.
 - 2. Warranty Period: 2 years from date of Substantial Completion.

PART 2 - PRODUCTS

2.1 PERFORMANCE CRITERIA

- A. Delegated Design: Engage a qualified professional engineer, as defined in Section 014000 – Quality Requirements, to design seismic bracing of tracks to structure above.
- B. Seismic Performance: Operable panel partitions shall withstand effects of earthquake motions determined according to ASCE 7.
 - 1. The term "withstand" means " partition panels will remain in place without separation of any parts when subjected to seismic forces specified."

- C. Acoustical Performance: Provide operable panel partitions tested by a qualified testing agency for the following acoustical properties according to test methods indicated:
 - 1. Sound-Transmission Requirements: Operable panel partition assembly tested for laboratory sound-transmission loss performance according to ASTM E90, determined by ASTM E413, and rated for not less than STC indicated.
 - 2. Noise-Reduction Requirements: Operable panel partition assembly, identical to partition tested for STC, tested for sound-absorption performance according to ASTM C423, and rated for not less than NRC indicated.
 - 3. Noise-Isolation Requirements: Installed operable panel partition assembly, identical to partition tested for STC, tested for NIC according to ASTM E336, determined by ASTM E413, and rated for 10 dB less than STC value indicated.

- D. Fire-Test-Response Characteristics: Provide panels with finishes complying with one of the following as determined by testing identical products by a testing and inspecting agency acceptable to authorities having jurisdiction:
 - 1. Surface-Burning Characteristics: Comply with ASTM E84; testing by a qualified testing agency. Identify products with appropriate markings of applicable testing agency.
 - a. Flame-Spread Index: 25 or less.
 - b. Smoke-Developed Index: 450 or less.
 - 2. Fire Growth Contribution: Complying with acceptance criteria of local code and authorities having jurisdiction when tested per NFPA 265 Method B Protocol or NFPA 286.

- E. Adhesive: Mildew-resistant, nonstaining, strippable adhesive, for use with specific wall covering and substrate application; as recommended in writing by wall covering manufacturer:
 - 1. Verify adhesives have a VOC content of 50 g/L or less.
 - 2. Verify that adhesives meet testing and product requirements of California Department of Public Health's "Standard Method for the Testing and Evaluation of Volatile Organic Chemical Emissions from Indoor Sources Using Environmental Chambers."

- F. Recycled Content: Postconsumer recycled content plus 1/2 of preconsumer recycled content not less than 50 percent.

2.2 OPERABLE ACOUSTICAL PANELS

- A. Panel Construction, General: As required to support panel from suspension components and with reinforcement for hardware attachment. Fabricate panels with tight hairline joints and concealed fasteners. Fabricate panels so finished in-place partition is rigid; level; plumb; aligned, with tight joints and uniform appearance; and free of bow, warp, twist, deformation, and surface and finish irregularities.

- B. Operable Panel Partition (Type-1): Manually-operated paired panel partition system, including panels, seals, finish facing, suspension system, operators, and accessories.
 - 1. Basis-of-Design Product: Subject to compliance with requirements, provide Series 632 by Hufcor, Inc. or approved substitution by one of the following:
 - a. Advanced Equipment Corporation.
 - b. KWIK-WALL Company.
 - c. Moderco Inc.
 - d. Modernfold, Inc.
 - e. Panelfold Inc.
 - 2. Panel Operation: Manually operated, paired panels.
 - 3. Dimensions: Fabricate operable acoustical panel partitions to form an assembled system of dimensions indicated and verified by field measurements.
 - a. Panel Width: Equal widths unless indicated otherwise.
 - 4. STC: Not less than 51.
 - 5. Panel Weight: 10.2 lb/sq. ft. maximum.

6. Panel Thickness: Nominal dimension of 3 inches.
 - a. Steel Frame: Manufacturer's standard nominal 0.0641 inch thick steel sheet with factory-applied finish coating.
 - b. Steel Face/Liner Sheets: Tension-leveled steel sheet, manufacturer's standard minimum nominal thickness for uncoated steel.
 7. Panel Closure: Manufacturer's standard unless otherwise indicated.
 - a. Final Closure: Constant-force, lever-operated mechanical closure expanding from panel edge to create a constant-pressure acoustical seal.
 8. Hardware: Manufacturer's standard as required to operate operable panel partition and accessories; with decorative, protective finish.
 9. Finish Facing: Manufacturer's standard vinyl-coated fabric wall covering.
- C. Operable Panel Partition (Type-2): Manually-operated paired panel partition system, including panels, seals, finish facing, suspension system, operators, and accessories.
1. Basis-of-Design Product: Subject to compliance with requirements, provide Series 642 by Hufcor, Inc. or approved substitution by one of the following:
 - a. Advanced Equipment Corporation.
 - b. KWIK-WALL Company.
 - c. Moderco Inc.
 - d. Modernfold, Inc.
 - e. Panelfold Inc.
 2. Panel Operation: Manually operated, paired panels.
 3. Dimensions: Fabricate operable acoustical panel partitions to form an assembled system of dimensions indicated and verified by field measurements.
 - a. Panel Width: Equal widths unless indicated otherwise.
 4. STC: Not less than 56.
 5. Panel Weight: 13.6 lb/sq. ft. maximum.
 6. Panel Thickness: Nominal dimension of 4 inches.
 - a. Steel Frame: Manufacturer's standard nominal 0.0641 inch thick steel sheet with factory-applied finish coating.
 - b. Steel Face/Liner Sheets: Tension-leveled steel sheet, manufacturer's standard minimum nominal thickness for uncoated steel.
 7. Panel Closure: Manufacturer's standard unless otherwise indicated.
 - a. Final Closure: Constant-force, lever-operated mechanical closure expanding from panel edge to create a constant-pressure acoustical seal.
 8. Hardware: Manufacturer's standard as required to operate operable panel partition and accessories; with decorative, protective finish.
 9. Finish Facing: Manufacturer's standard vinyl-coated fabric wall covering.

2.3 SEALS

- A. Description: Seals that produce operable panel partitions complying with performance requirements and the following:
 1. Manufacturer's standard seals unless otherwise indicated.
 2. Seals made from materials and in profiles that minimize sound leakage.
 3. Seals fitting tight at contact surfaces and sealing continuously between adjacent panels and between operable panel partition perimeter and adjacent surfaces, when operable panel partition is extended and closed.
- B. Vertical Seals: Deep-nesting, interlocking astragals mounted on each edge of panel, with continuous, resilient acoustical seal.
- C. Horizontal Top Seals: Fixed, resilient, constant-force-contact seal exerting uniform constant pressure on track when extended.

- D. Horizontal Bottom Seals: Retractable, resilient, mechanical, constant-force-contact seal exerting uniform constant pressure on floor when extended, ensuring horizontal and vertical sealing and resisting panel movement.
 - 1. Mechanically Operated for Acoustical Panels: Extension and retraction of bottom seal by operating handle or built-in operating mechanism, with operating range not less than 2 inches between retracted seal and floor finish.

2.4 PANEL FINISH FACINGS

- A. Description: Finish facings for panels that comply with indicated fire-test-response characteristics and that are factory applied to operable panel partitions with appropriate backing, using mildew-resistant nonstaining adhesive as recommended by facing manufacturer's written instructions.
 - 1. Apply facings free of air bubbles, wrinkles, blisters, and other defects, with invisible seams complying with Shop Drawings for location, and with no gaps or overlaps. Horizontal seams are not permitted. Tightly secure and conceal raw and selvage edges of facing for finished appearance.
 - 2. Where facings with directional or repeating patterns or directional weave are indicated, mark facing top and attach facing in same direction.
 - 3. Match facing pattern 72 inches above finished floor.
- B. Vinyl-Coated Fabric Wall Covering: Manufacturer's standard, mildew-resistant, washable, vinyl-coated fabric wall covering; Class A.
 - 1. Total Weight: Not less than 15 oz./lin. yd.
 - 2. Factory applied reinforced vinyl fabric with woven backing, weighing not less than 20 oz. per lineal yard.
 - 3. Antimicrobial Treatment: Additives capable of inhibiting growth of bacteria, fungi, and yeasts.
 - 4. Color/Pattern: As selected by Architect from manufacturer's full range.
- C. Cap-Trimmed Edges: Protective perimeter-edge trim with tight hairline joints concealing edges of panel and finish facing, finished as follows:
 - 1. Aluminum: Finished with manufacturer's standard clear anodic finish unless indicated otherwise.

2.5 SUSPENSION SYSTEMS

- A. Tracks: Aluminum mounted directly to overhead structural support or with adjustable steel hanger rods for overhead support, designed for operation, size, and weight of operable panel partition indicated. Size track to support partition operation and storage without damage to suspension system, operable panel partitions, or adjacent construction. Limit track deflection to no more than 0.10 inch between bracket supports. Provide a continuous system of track sections and accessories to accommodate configuration and layout indicated for partition operation and storage.
 - 1. Panel Guide: Aluminum guide on both sides of track to facilitate straightening of panels; finished with factory-applied, decorative, protective finish.
 - a. Provide panel guides with integral support for adjoining ceilings and soffits.
 - 2. Head Closure Trim: As required for acoustical performance; with factory-applied, decorative, protective finish.
- B. Carriers: Trolley system as required for configuration type, size, and weight of partition and for easy operation; with ball-bearing wheels.
- C. Track Intersections, Switches, and Accessories: As required for operation, storage, track configuration, and layout indicated for operable panel partitions, and compatible with partition assembly specified. Fabricate track intersections and switches from steel or aluminum to match track material.
 - 1. Curve-and-Diverter Switches: Allow radius turns to divert panels to an auxiliary track.
 - 2. L Intersections: Allow panels to change 90 degrees in direction of travel.

3. T Intersections: Allow panels to pass through or change 90 degrees to another direction of travel.
 4. X Intersections: Allow panels to pass through or change travel direction full circle in 90-degree increments, and allow one partition to cross track of another.
 5. Multidirectional Switches: Adjustable switch configuring track into L, T, or X intersections and allowing panels to be moved in all pass-through, 90-degree change, and cross-over travel direction combinations.
- D. Aluminum Finish: Mill finish or manufacturer's standard, factory-applied, decorative finish unless otherwise indicated.
- E. Steel Finish: Manufacturer's standard, factory-applied, corrosion-resistant, protective coating unless otherwise indicated.
- 2.6 ACCESSORIES
- A. Storage Pocket Door: Full height at end of partition runs to conceal stacked partition; of same materials, finish, construction, thickness, and acoustical qualities as panels; complete with operating hardware. Hinges in finish to match other exposed hardware.
1. Rim Lock: Key-operated lock cylinder, keyed to master key system, to secure storage pocket door in closed position. Include 2 keys per lock. See Section 087100 – Door Hardware for lock cylinder and keying requirements.

PART 3 - EXECUTION

3.1 EXAMINATION

- A. Examine flooring, floor levelness, structural support, and opening, with Installer present, for compliance with requirements for installation tolerances and other conditions affecting performance of operable panel partitions.
- B. Proceed with installation only after unsatisfactory conditions have been corrected.

3.2 INSTALLATION

- A. Install operable panel partitions and accessories after other finishing operations, including painting, have been completed in area of partition installation.
- B. Install panels in numbered sequence indicated on Shop Drawings.
- C. Broken, cracked, chipped, deformed, or unmatched panels are not acceptable.
- D. Broken, cracked, deformed, or unmatched gasketing or gasketing with gaps at butted ends is not acceptable.
- E. Light-Leakage Test: Illuminate 1 side of partition installation and observe vertical joints and top and bottom seals for voids. Adjust partitions for alignment and full closure of vertical joints and full closure along top and bottom seals. Perform test and make adjustments before NIC testing.

3.3 FIELD QUALITY CONTROL

- A. NIC Testing: Owner will engage a qualified testing agency to perform tests and inspections.
1. Testing Extent: Testing agency shall randomly select 1 operable panel partition installations for testing.
 2. Testing Methodology: Perform testing of installed operable panel partition for noise isolation according to ASTM E336, determined by ASTM E413, and rated for not less than NIC indicated. Adjust and fit partitions to comply with NIC test method requirements.

- B. An operable panel partition installation will be considered defective if it does not pass tests and inspections.
- C. Prepare test and inspection reports.

3.4 ADJUSTING

- A. Adjust operable panel partitions, hardware, and other moving parts to function smoothly, and lubricate as recommended by manufacturer.
- B. Adjust storage pocket doors to operate smoothly and easily, without binding or warping.
- C. Verify that safety devices are properly functioning.

3.5 MAINTENANCE SERVICE

- A. Maintenance Service: Beginning at Substantial Completion, maintenance service shall include 12 months' full maintenance by manufacturer's authorized service representative. Include quarterly preventive maintenance, repair or replacement of worn or defective components, lubrication, cleaning, and adjusting as required for proper operable-partition operation. Parts and supplies shall be manufacturer's authorized replacement parts and supplies.

3.6 DEMONSTRATION

- A. Engage a factory-authorized service representative to train Owner's maintenance personnel to adjust, operate, and maintain operable panel partitions.

END OF SECTION 102239

SECTION 102813
TOILET and BATH ACCESSORIES

PART 1 - GENERAL

1.1 SUMMARY

- A. Section Includes:
1. Toilet and bath accessories.
 2. Shower and bath accessories.
 3. Healthcare accessories.
 4. Warm-air dryers.
 5. Childcare accessories.
 6. Underlavatory guards.
 7. Custodial accessories.
 8. Miscellaneous accessories.

1.2 ADMINISTRATIVE REQUIREMENTS

- A. Coordination:
1. Coordinate accessory locations with other Work to prevent interference with clearances required for access by people with disabilities, and for proper installation, adjustment, operation, cleaning, and servicing of accessories.
 2. Deliver inserts and anchoring devices set into concrete or masonry as required to prevent delaying Work.

1.3 ACTION SUBMITTALS

- A. Product Data: For each type of product.
1. Include construction details, material descriptions, dimensions of individual components and profiles, and finishes.
 2. Include anchoring and mounting requirements, including requirements for cutouts in other Work and substrate preparation.
 3. Include electrical characteristics.
- B. Samples: Full size, for each accessory item to verify design, operation, and finish requirements.
1. Approved full-size Samples will be returned and may be used in Work.
- C. Product Schedule: Indicating types, quantities, sizes, and installation locations by room of each accessory required.
1. Identify locations using room designations indicated.
 2. Identify products using designations indicated.

1.4 INFORMATIONAL SUBMITTALS

- A. Sample Warranty: For manufacturer's special warranty.

1.5 CLOSEOUT SUBMITTALS

- A. Maintenance Data: For accessories to include in maintenance manuals.

1.6 WARRANTY

- A. Manufacturer's Special Warranty for Mirrors: Manufacturer agrees to repair or replace mirrors that fail in materials or workmanship within specified warranty period.

1. Warranty Period: 15 years from date of Substantial Completion.

PART 2 - PRODUCTS

2.1 PERFORMANCE CRITERIA

- A. Electrical Components, Devices, and Accessories: Listed and labeled as defined in NFPA 70, by a qualified testing agency, and marked for intended location and application.

2.2 MANUFACTURERS

- A. Basis-of-Design Product: Subject to compliance with requirements, provide specified products or comparable product by one of the following:
 1. AJW Architectural Products
 2. American Specialties, Inc.
 3. Bobrick Washroom Equipment, Inc.
 4. Bradley Corporation.
 5. Gamco Commercial Restroom Accessories; a division of Bobrick Washroom Equipment, Inc.
 6. Tubular Specialties Manufacturing, Inc.
- B. Source Limitations: Obtain toilet and bath accessories from single source from single manufacturer.

2.3 OWNER-FURNISHED MATERIALS

- A. Owner-Furnished Materials: Where indicated on Drawings, Owner will furnish the following for installation by Contractor:
 1. Soap Dispenser.
 2. Toilet Tissue Dispenser.
 3. Paper towel dispensers.
 4. Paper towel disposals.
 5. Toilet seat cover dispensers.
 6. Waste receptacles.

2.4 WASHROOM ACCESSORIES

- A. Toilet Tissue Holder/Toilet Seat Cover Dispenser/Sanitary Napkin Disposal.
- B. Toilet Tissue Holder/Toilet Seat Cover Dispenser:
- C. Paper Towel Cabinet
- D. Paper Towel Cabinet/Waste Receptacle
- E. Paper Towel Cabinet:
- F. Soap Dispenser

2.5 MATERIALS

- A. Stainless Steel: ASTM A240 or ASTM A666, Type 304, 0.031 inch minimum nominal thickness unless otherwise indicated.
- B. Brass: ASTM B19, flat products; ASTM B16, rods, shapes, forgings, and flat products with finished edges; or ASTM B30, castings.
- C. Steel Sheet: ASTM A1008, Designation CS (cold rolled, commercial steel), 0.036 inch minimum nominal thickness.

- D. Galvanized-Steel Sheet: ASTM A653, with G60 hot-dip zinc coating.
- E. Galvanized-Steel Mounting Devices: ASTM A153, hot-dip galvanized after fabrication.
- F. Fasteners: Screws, bolts, and other devices of same material as accessory unit and tamper-and-theft resistant where exposed, and of galvanized steel where concealed unless indicated otherwise.
- G. Chrome Plating: ASTM B456, Service Condition Number SC 2 (moderate service).
- H. Mirrors: ASTM C1503, Mirror Glazing Quality, clear-glass mirrors, nominal 6.0 mm thick.

2.6 FABRICATION

- A. General: Fabricate units with tight seams and joints, and exposed edges rolled. Hang doors and access panels with full-length, continuous hinges. Equip units for concealed anchorage and with corrosion-resistant backing plates.
- B. Mirror Frame Filler:
 - 1. Where framed mirrors are mounted on walls having ceramic tile wainscots not flush with wall above, provide fillers at void between back of mirror and wall surface.
 - 2. Fabricate fillers from same material and finish as mirror frame, contoured to conceal void behind mirror at sides and top.
- C. Keys: Provide universal keys for internal access to accessories for servicing and resupplying. Provide minimum of 6 keys to Owner's representative.

PART 3 - EXECUTION

3.1 INSTALLATION

- A. Install accessories according to manufacturers' written instructions, using fasteners appropriate to substrate indicated and recommended by unit manufacturer. Install units level, plumb, and firmly anchored in locations and at heights indicated.
- B. Grab Bars: Install to withstand a downward load of at least 250 lbf, when tested according to ASTM F446.

END OF SECTION 102800

SECTION 104413
FIRE PROTECTION CABINETS

PART 1 - GENERAL

1.1 SUMMARY

- A. Section Includes:
 - 1. Fire-protection cabinets for portable fire extinguisher.

1.2 ADMINISTRATIVE REQUIREMENTS

- A. Coordination:
 - 1. Coordinate size of fire protection cabinets to ensure that type and capacity of fire extinguishers indicated are accommodated.
 - 2. Coordinate sizes and locations of fire protection cabinets with wall depths.
- B. Preinstallation Meetings: Conduct meeting at Project.
 - 1. Review methods and procedures related to fire protection cabinets including schedules and coordination requirements.

1.3 ACTION SUBMITTALS

- A. Product Data: For each type of product.
 - 1. Show door hardware, cabinet type, trim style, and panel style. Include roughing-in dimensions and details showing recessed-, semi-recessed-, or surface-mounting method and relationships of box and trim to surrounding construction.
- B. Shop Drawings: For fire-protection cabinets.
 - 1. Include plans, elevations, sections, details, and attachments to other Work.
- C. Samples for Verification: For each type of exposed finish required, prepared on samples 6 by 6 inches square.
- D. Product Schedule: For fire-protection cabinets. Indicate whether recessed, semi-recessed, or surface mounted. Coordinate final fire-protection cabinet schedule with fire-extinguisher schedule to ensure proper fit and function. Use same designations indicated on Drawings if indicated.

1.4 CLOSEOUT SUBMITTALS

- A. Maintenance Data: For fire-protection cabinets to include in maintenance manuals.

PART 2 - PRODUCTS

2.1 MANUFACTURERS

- A. Source Limitations: Obtain fire-protection cabinets, fire extinguishers, accessories and from single source from single manufacturer.

2.2 PERFORMANCE CRITERIA

- A. Fire-Rated Fire-Protection Cabinets: Listed and labeled to comply with requirements in ASTM E814 for fire-resistance rating of walls where they are installed.

2.3 FIRE-PROTECTION CABINETS

- A. Cabinet Type-FEC-1: Suitable for fire extinguisher. Surface-mounted cabinet box fully exposed and mounted directly on wall with no trim.
1. Products: Subject to compliance with requirements, provide one of the following:
 - a. J. L. Industries, Inc.: Ambassador Series 1013.
 - b. Larsen's Manufacturing Company: 2409-SM.
 - c. Potter Roemer LLC. Alta Series7024.
 - d. Approved substitution.
 2. Nominal Cabinet Size: Verify rough openings once product has been selected.
 - a. Height: 26-1/2 to 27-3/16 inches.
 - b. Width: 11-1/2 to 13-11/16 inches.
 - c. Depth: 5-3/4 to 6-1/2 inches.
 3. Cabinet Construction: Non-rated.
 4. Cabinet Material: Cold-rolled steel sheet.
 5. Cabinet Trim Material: Same material and finish as door.
 6. Door Material: Steel sheet.
 7. Door Style: Vertical duo panel with frame.
 8. Door Glazing: Transparent acrylic sheet.
 9. Capacity: For use with Type 1 10 lb. fire extinguisher.
 10. Locations: Parking garages, ramps, other unconditioned areas where indicated, and where required by local fire official.
- B. Cabinet Type-FEC-2: Suitable for fire extinguisher. Fire-rated, recessed cabinet with 1 piece combination trim and perimeter door frame overlapping surrounding wall surface, with exposed trim face and wall return at outer edge (backbend).
1. Products: Subject to compliance with requirements, provide one of the following:
 - a. J. L. Industries, Inc.: Academy Series 1825FX2.
 - b. Larsen's Manufacturing Company: FS AL2409-R1.
 - c. Potter Roemer LLC. Alta Series FRC7030.
 - d. Approved substitution.
 2. Nominal Cabinet Size: Verify rough openings once product has been selected.
 - a. Height: 24 inches.
 - b. Width: 9 to 10-1/2 inches.
 - c. Depth: 5 to 5-1/2 inches.
 3. Cabinet Construction: Match fire-rating of wall in which cabinet is mounted.
 - a. Fire-Rated Cabinets: Construct fire-rated cabinets with double walls fabricated from 0.043 inch thick cold-rolled steel sheet lined with minimum 5/8 inch thick fire-barrier material. Provide factory-drilled mounting holes.
 4. Cabinet Material: Cold-rolled steel sheet.
 5. Cabinet Trim Material: Same material and finish as door.
 6. Door Material: Aluminum sheet.
 7. Door Style: Vertical duo panel with frame.
 8. Door Glazing: Transparent acrylic sheet.
 9. Capacity: For use with Type 2 5 lb. fire extinguisher.
 10. Locations: Interior common areas, corridors, other conditioned areas where indicated, and where required by local fire official.
- C. Door Hardware: Manufacturer's standard door-operating hardware of proper type for cabinet type, trim style, and door material and style indicated.
1. Provide manufacturer's recessed door pull where required by ADA Accessibility Guidelines.
 2. Provide continuous hinge, of same material and finish as trim, permitting door to open 180 degrees.

D. Accessories:

1. Mounting Bracket: Manufacturer's standard steel, designed to secure fire extinguisher to fire-protection cabinet, of sizes required for types and capacities of fire extinguishers indicated, with plated or baked-enamel finish.
2. Non-Break Glass Cabinet Lock: Safety-type cam lock that allows door to be opened during emergency by pulling sharply on door handle.
 - a. Products: Subject to compliance with requirements, provide one of the following:
 - 1) JL Industries, Inc.; a division of Activar Construction Products Group: Saf-T-Lok.
 - 2) Larsen's Manufacturing Company: Larsen-Loc.
 - 3) Potter Roemer LLC. Break Rite.
 - 4) Approved substitution.
 - b. Above door lock, provide manufacturer's factory applied lettering reads: "IN CASE OF FIRE ONLY – PULL FIRMLY ON HANDLE".
3. Identification: Lettering complying with authorities having jurisdiction for letter style, size, spacing, and location. Locate as indicated.
 - a. Identify fire extinguisher in fire-protection cabinet with the words "FIRE EXTINGUISHER."
 - 1) Locations:
 - a) FEC-1: Applied to cabinet glazing.
 - b) FEC-2: Applied to cabinet door.
 - 2) Application Process: [].
 - a) FEC-1: Die-cut, pressure-sensitive vinyl letters.
 - b) FEC-2: Silk-screened.
 - 3) Lettering Color: Black.
 - 4) Orientation: Vertical.

E. Materials:

1. Cold-Rolled Steel Sheet: ASTM A1008, Commercial Steel (CS), Type B.
 - a. Finish: Baked enamel or powder coat.
 - b. Color: Manufacturer's standard white.
2. Aluminum: ASTM B209, with strength and durability characteristics of not less than Alloy 6063-T5 for aluminum sheet. ASTM B221 for extruded shapes.
 - a. Finish: Clear anodic.
3. Tempered Float Glass: ASTM C1048, Kind FT, Condition A, Type I, Quality q3, 3 mm thick, Class 1 (clear).
4. Transparent Acrylic Sheet: ASTM D4802, Category A-1 (cell-cast sheet), 3 mm thick, with Finish 1 (smooth or polished).

2.4 FABRICATION

- A. Fire-Protection Cabinets: Provide manufacturer's standard box (tub) with trim, frame, door, and hardware to suit cabinet type, trim style, and door style indicated.
 1. Weld joints and grind smooth.
 2. Miter corners and grind smooth.
 3. Provide factory-drilled mounting holes.
 4. Prepare doors and frames to receive locks.
 5. Install door locks at factory.
- B. Cabinet Doors: Fabricate doors according to manufacturer's standards, from materials indicated and coordinated with cabinet types and trim styles.
 1. Fabricate door frames with tubular stiles and rails and hollow-metal design, minimum 1/2 inch thick.
 2. Miter and weld perimeter door frames and grind smooth.
- C. Cabinet Trim: Fabricate cabinet trim in 1 piece with corners mitered, welded, and ground smooth.

2.5 GENERAL FINISH REQUIREMENTS

- A. Comply with NAAMM's AMP 500, "Metal Finishes Manual for Architectural and Metal Products," for recommendations for applying and designating finishes.
- B. Protect mechanical finishes on exposed surfaces of fire-protection cabinets from damage by applying a strippable, temporary protective covering before shipping.
- C. Finish fire-protection cabinets after assembly.
- D. Appearance of Finished Work: Noticeable variations in same piece are unacceptable. Variations in appearance of adjoining components are acceptable if they are within range of approved Samples and are assembled or installed to minimize contrast.

PART 3 - EXECUTION

3.1 EXAMINATION

- A. Examine walls and partitions for suitable framing depth and blocking where recessed cabinets will be installed.
- B. Proceed with installation only after unsatisfactory conditions have been corrected.

3.2 PREPARATION

- A. Prepare recesses for recessed and semi-recessed fire-protection cabinets as required by type and size of cabinet and trim style.

3.3 INSTALLATION

- A. General: Install fire-protection cabinets in locations and at mounting heights indicated or, if not indicated, at height indicated below:
 - 1. Fire-Protection Cabinets: 42 inches above finished floor to top of fire extinguisher.
- B. Fire-Protection Cabinets: Fasten cabinets to structure, square and plumb.
 - 1. Unless otherwise indicated, provide recessed fire-protection cabinets. If wall thickness is inadequate for recessed cabinets, provide semi-recessed fire-protection cabinets.
 - 2. Provide inside latch and lock for break-glass panels.
 - 3. Fasten mounting brackets to inside surface of fire-protection cabinets, square and plumb.
- C. Identification:
 - 1. Apply die-cut vinyl lettering at locations indicated.

3.4 REPAIR

- A. Touch up marred finishes, or replace fire-protection cabinets that cannot be restored to factory-finished appearance. Use only materials and procedures recommended or furnished by fire-protection cabinet and mounting bracket manufacturers.
- B. Replace fire-protection cabinets that have been damaged or have deteriorated beyond successful repair by finish touchup or similar minor repair procedures.

3.5 ADJUSTING

- A. Remove temporary protective coverings and strippable films, if any, as fire-protection cabinets are installed unless otherwise indicated in manufacturer's written installation instructions.
- B. Adjust fire-protection cabinet doors to operate easily without binding. Verify that integral locking devices operate properly.

3.6 CLEANING

- A. On completion of fire-protection cabinet installation, clean interior and exterior surfaces as recommended by manufacturer.

END OF SECTION 104413

SECTION 104416
FIRE EXTINGUISHERS

PART 1 - GENERAL

1.1 SUMMARY

- A. Section Includes:
 - 1. Portable, hand-carried fire extinguishers and mounting brackets for fire extinguishers.

1.2 ADMINISTRATIVE REQUIREMENTS

- A. Coordination:
 - 1. Coordinate type and capacity of fire extinguishers with fire protection cabinets to ensure fit and function.
- B. Preinstallation Meeting: Conduct meeting at Project site.
 - 1. Review methods and procedures related to fire extinguishers including schedules and coordination requirements.

1.3 ACTION SUBMITTALS

- A. Product Data: For each type of product. Include rating and classification, material descriptions, dimensions of individual components and profiles, and finishes for fire extinguisher and mounting brackets.
- B. Product Schedule: For fire extinguishers. Coordinate final fire-extinguisher schedule with fire-protection cabinet schedule to ensure proper fit and function. Use same designations indicated on Drawings if indicated.

1.4 INFORMATIONAL SUBMITTALS

- A. Warranty: Sample of special warranty.

1.5 CLOSEOUT SUBMITTALS

- A. Operation and Maintenance Data: For fire extinguishers to include in maintenance manuals.

1.6 WARRANTY

- A. Special Warranty: Manufacturer's standard form in which manufacturer agrees to repair or replace fire extinguishers that fail in materials or workmanship within specified warranty period.
 - 1. Failures include the following:
 - a. Failure of hydrostatic test according to NFPA 10.
 - b. Faulty operation of valves or release levers.
 - 2. Warranty Period: 6 years from date of Substantial Completion.

PART 2 - PRODUCTS

2.1 MANUFACTURERS

- A. Source Limitations: Obtain fire extinguishers, fire-protection cabinets, and accessories, from single source from single manufacturer.

2.2 PERFORMANCE CRITERIA

- A. NFPA Compliance: Fabricate and label fire extinguishers to comply with NFPA 10, "Portable Fire Extinguishers."
- B. Fire Extinguishers: Listed and labeled for type, rating, and classification by an independent testing agency acceptable to authorities having jurisdiction.

2.3 PORTABLE, HAND-CARRIED FIRE EXTINGUISHERS

- A. Fire Extinguishers, General: Type, size, and capacity for each fire-protection cabinet and mounting bracket indicated.
 - 1. Valves: Manufacturer's standard.
 - 2. Handles and Levers: Manufacturer's standard stainless steel.
 - 3. Instruction Labels: Include pictorial marking system complying with NFPA 10, Appendix B, and bar coding for documenting fire-extinguisher location, inspections, maintenance, and recharging.
- B. Multipurpose Dry-Chemical Type in Steel Container (Type 1): UL-rated, with monoammonium phosphate-based dry chemical in enameled-steel container.
 - 1. Type 2 Products: Subject to compliance with requirements, provide one of the following:
 - a. JL Industries, Inc.: Model Cosmic 10E.
 - b. Larsen's Manufacturing Company: MP10.
 - c. Potter Roemer LLC. Model Number 3010.
 - d. Approved substitution.
 - 2. Nominal Capacity: 10 lb.
 - 3. UL Rating: 4A-80B:C.
 - 4. Finish Color: Red.
 - 5. Locations: Parking garages, ramps, other unconditioned areas where indicated, and where required by local fire official.
- C. Multipurpose Dry-Chemical Type in Steel Container (Type 2): UL-rated, with monoammonium phosphate-based dry chemical in enameled-steel container.
 - 1. Products: Subject to compliance with requirements, provide one of the following:
 - a. JL Industries, Inc.: Model Cosmic 5E.
 - b. Larsen's Manufacturing Company: MP5.
 - c. Potter Roemer LLC. Model Number 3005.
 - d. Approved substitution.
 - 2. Nominal Capacity: 5 lb.
 - 3. UL Rating: 2A:10B:C.
 - 4. Locations: Interior common areas, corridors, other conditioned areas where indicated, and where required by local fire official.

2.4 MOUNTING BRACKETS

- A. Mounting Brackets: Manufacturer's standard galvanized steel, designed to secure fire extinguisher to wall or structure, of sizes required for types and capacities of fire extinguishers indicated, with plated or red baked-enamel finish.
 - 1. Source Limitations: Obtain mounting brackets and fire extinguishers from single source from single manufacturer.
- B. Identification: Lettering complying with authorities having jurisdiction for letter style, size, spacing, and location. Locate as indicated by Architect.
 - 1. Identify bracket-mounted fire extinguishers with the words "FIRE EXTINGUISHER" in red letter decals applied to mounting surface.
 - a. Orientation: Vertical.

PART 3 - EXECUTION

3.1 EXAMINATION

- A. Examine fire extinguishers for proper charging and tagging.
 - 1. Remove and replace damaged, defective, or undercharged fire extinguishers.
- B. Proceed with installation only after unsatisfactory conditions have been corrected.

3.2 INSTALLATION

- A. General: Install fire extinguishers in locations indicated and in compliance with requirements of authorities having jurisdiction.
 - 1. Mounting Brackets: Top of fire extinguisher to be at 42 inches above finished floor.
- B. Mounting Brackets: Fasten mounting brackets to surfaces, square and plumb, at locations indicated.

END OF SECTION 104416

SECTION 105500
USPS-DELIVERY POSTAL SPECIALTIES

PART 1 - GENERAL

1.1 SUMMARY

- A. Section Includes:
 - 1. Mail receptacles.
 - 2. Collection boxes.
 - 3. Accessories.

1.2 ADMINISTRATIVE REQUIREMENTS

- A. Coordination:
 - 1. Coordinate layout and installation of recessed postal specialties with wall construction.
 - 2. Templates: Obtain templates for installing postal specialties and distribute to parties involved.

1.3 ACTION SUBMITTALS

- A. Product Data: For each type of product.
 - 1. Include construction details, material descriptions, dimensions of individual components and profiles, and finishes for each type of postal specialty.
- B. Shop Drawings: For postal specialties.
 - 1. Include plans, elevations, sections, and attachment details.
 - 2. Include identification sequence for compartments.
 - 3. Include layout of identification text.
 - 4. Include setting drawings, templates, and installation instructions for anchor bolts and other anchorages installed as part of the Work of other Sections.
- C. Samples for Verification: For each type of exposed finish, prepared on 6 by 6 inch square Samples.

1.4 INFORMATIONAL SUBMITTALS

- A. Product Certificates: For each type of postal specialty required to comply with USPS regulations, signed by product manufacturer. Include written approval by Postmaster General.
- B. Sample Warranty: For special warranty.

1.5 CLOSEOUT SUBMITTALS

- A. Maintenance Data: For postal specialties and finishes to include in maintenance manuals.

1.6 MAINTENANCE MATERIAL SUBMITTALS

- A. Furnish extra materials that match products installed and that are packaged with protective covering for storage and identified with labels describing contents.
 - 1. Key Blanks: 3 keys for each lock, for each type of compartment-door lock installed.

1.7 DELIVERY, STORAGE, AND HANDLING

- A. Furnish lock keys according to USPS requirements; with temporary identification for their respective locks, bagged, and securely taped inside the collection compartment for shipping.

1.8 WARRANTY

- A. Special Warranty: Manufacturer agrees to repair or replace components of postal specialties that fail in materials or workmanship within specified warranty period.
 - 1. Failures include the following:
 - a. Structural failures.
 - b. Faulty operation of hardware.
 - c. Deterioration of metals, metal finishes, and other materials beyond normal weathering.
 - 2. Warranty Period: 1 years from date of Substantial Completion.

PART 2 - PRODUCTS

2.1 MAIL RECEPTACLES

- A. Front-Loading Mail Receptacles: Consisting of multiple compartments with fixed, solid compartment backs, enclosed within a recessed wall box. Provide access to compartments for distributing incoming mail from front of unit by unlocking master lock and swinging side-hinged master door to provide accessibility to entire group of compartments. Provide access to each compartment for removing mail by swinging compartment door. Comply with USPS-STD-4C.
 - 1. Basis-of-Design Product: Subject to compliance with requirements, provide the following:
 - a. Florence Corporation: Model versatile 4C16D-20.
 - b. Approved substitution from one of the following:
 - 1) Bommer Industries, Inc.
 - 2) Salsbury Industries.
 - 2. Front-Loading Master Door: Fabricated from extruded aluminum and braced and framed to hold compartment doors; prepared to receive master-door lock.
 - a. Master-Door Lock: Door prepared to receive lock provided by local postmaster.
 - 3. Compartments: As indicated on Drawings:
 - 4. Compartment Doors: Fabricated from extruded aluminum. Equip each with lock and tenant identification as required by USPS-STD-4C. Provide mail slot in compartment with master-door lock.
 - a. Compartment-Door Locks: Comply with USPS-L-1172C for locks and keys, or equivalent as approved by USPS; with 3 keys for each compartment door. Key each compartment differently.
 - b. Parcel-Locker-Compartment-Door Locks: 2-key security system in which control key provides access to parcel-locker-compartment key, which opens compartment and is retained once opened.
 - 5. Frames: Fabricated from extruded aluminum or aluminum sheet; ganged and nested units, with cardholder and blank cards for tenant's identification within each compartment.
 - 6. Concealed Components and Mounting Frames: Aluminum or steel sheet with manufacturer's standard finish.
 - 7. Exposed Materials: Fabricated from extruded or sheet aluminum.
 - a. Anodic Finish: Dark bronze.

2.2 COLLECTION BOXES

- A. Front-Loading Collection Boxes: Consisting of single compartment with fire-resistant cushion bottom, enclosed within wall box, with mail slot to receive mail. Provide door for collecting mail from front of unit.
 - 1. Manufacturer: Same as mail receptacles.
 - 2. Mounting: As indicated on Drawings.
 - 3. Height: As indicated on Drawings.

4. Compartment Doors and Frames: Fabricated from 1/4 inch thick aluminum, with opening not less than 12 by 20 inches and not more than 18 by 30 inches. Equip door with lock and concealed, full-length, flush hinge on one side.
 - a. Door Lock: Door prepared to receive lock provided by local postmaster.
 - b. Identification: Engrave face of compartment door with 1 inch high letters as follows: "U.S. MAIL LETTER BOX" on 2 lines at top or bottom of unit.
5. Mail Slot: Fabricated from 1/4 inch thick aluminum, with 11 inch wide by 1-1/4 inch high opening, protected by inside hood and hinge flap, and with inside baffle to prevent removal of mail from box.
6. Exposed Materials: Fabricated from extruded or sheet aluminum.
 - a. Anodic Finish: Dark bronze.
7. Concealed Components and Mounting Frames: Aluminum or steel sheet with manufacturer's standard finish.
8. Schedule-Card Holder: Recessed or surface-mounted holder for pickup schedule card in center of bottom front portion of unit. Fabricate of same material and finish as front of unit.
9. Mailbag Rack: Internal rack system for supporting mailbags within unit.

2.3 ACCESSORIES

- A. Key Keeper: Consisting of single compartment with door; interior compartment size not less than 4-3/4 inches wide by 2-1/4 inches high by 1-1/2 inches deep; USPS approved.
 1. Manufacturer: Same as mail receptacles.
 2. Mounting: Recessed.
 3. Style: Compartment door set within face frame.
 4. Type of Operation: Retractor reel with minimum 20 inch long chain.
 5. Door Lock: Door prepared to receive lock furnished by local postmaster.
 6. Exposed Materials: Fabricated from extruded or sheet aluminum.
 - a. Anodic Finish: Clear.

2.4 FABRICATION

- A. Form postal specialties to required shapes and sizes, with true lines and angles, square, rigid, and without warp, and with metal faces flat and free of dents or distortion. Make exposed metal edges and corners free of sharp edges and burrs and safe to touch. Fabricate doors of postal specialties to preclude binding, warping, or misalignment.
- B. Preassemble postal specialties in shop to greatest extent possible to minimize field assembly.
- C. Mill joints to a tight, hairline fit. Cope or miter corner joints. Form joints exposed to weather to exclude water penetration.
- D. Drill or punch holes required for fasteners and remove burrs. Use security fasteners where fasteners are exposed. If used, seal external rivets before finishing.
- E. Weld in concealed locations to greatest extent possible without distorting or discoloring exposed surfaces. Remove weld spatter and welding oxides from exposed surfaces.
- F. Fabricate tubular and channel frame assemblies with manufacturer's standard welded or mechanical joints. Provide subframes and reinforcement as required for a complete system to support loads.
- G. Where dissimilar metals contact each other, protect against galvanic action by painting contact surfaces with bituminous coating or by applying other permanent separation as recommended by manufacturers of dissimilar metals.

2.5 GENERAL FINISH REQUIREMENTS

- A. Comply with NAAMM/NOMMA's "Metal Finishes Manual for Architectural and Metal Products (AMP 500-06)" for recommendations for applying and designating finishes.
- B. Protect mechanical finishes on exposed surfaces from damage by applying a strippable, temporary protective covering before shipping.
- C. Appearance of Finished Work: Noticeable variations in same piece are not acceptable. Variations in appearance of adjoining components are acceptable if they are within range of approved Samples and are assembled or installed to minimize contrast.

2.6 ALUMINUM FINISHES

- A. Color Anodic Finish: AAMA 611, AA-M12C22A42/A44, Class I, 0.018 mm or thicker.
 - 1. Color: Dark bronze.

PART 3 - EXECUTION

3.1 EXAMINATION

- A. Examine substrates, areas, and conditions, with Installer present, for compliance with requirements for roughing-in openings, clearances, and other conditions affecting performance of Work.
- B. Prepare written report, endorsed by Installer, listing conditions detrimental to performance of Work.
- C. Proceed with installation only after unsatisfactory conditions have been corrected.

3.2 INSTALLATION

- A. Install postal specialties level and plumb, according to manufacturer's written instructions.
 - 1. Where dissimilar metals contact each other, protect against galvanic action by painting contact surfaces with bituminous coating or by applying other permanent separation as recommended by manufacturer.
 - 2. Where aluminum contacts grout, concrete, masonry, or wood, protect against corrosion by painting contact surfaces with bituminous coating.
 - 3. Final acceptance of postal specialties served by USPS depends on compliance with USPS requirements.
- B. Mail Receptacles: Install mail receptacles with center of tenant-door lock cylinders and bottom of compartments at the maximum and minimum heights above finished floor established by the USPS and manufacturer's written instructions.
 - 1. Install removable-core and keyed-in door lock cylinders as required for each type of cylinder lock.

3.3 FIELD QUALITY CONTROL

- A. Arrange for USPS personnel to examine and test postal specialties served by USPS after they have been installed according to USPS regulations.

3.4 ADJUSTING

- A. Remove temporary protective coverings and strippable films, if any, as postal specialties are installed unless otherwise indicated in manufacturer's written installation instructions.
- B. Adjust doors, hardware, and moving parts to function smoothly, and lubricate as recommended by manufacturer. Verify that integral locking devices operate properly.

3.5 CLEANING

- A. Touch up marred finishes or replace postal specialties that cannot be restored to factory-finished appearance. Use only materials and procedures recommended or furnished by postal-specialty manufacturer.
- B. Replace postal specialties that have been damaged or have deteriorated beyond successful repair by finish touchup or similar minor repair procedures.
- C. On completion of postal-specialty installation, clean interior and exterior surfaces as recommended by manufacturer.

END OF SECTION 105500

SECTION 105700
WARDROBE AND CLOSET SPECIALTIES

PART 1 - GENERAL

1.1 SUMMARY

- A. Section Includes:
1. Prefabricated, modular, wire shelving system.

1.2 ACTION SUBMITTALS

- A. Product Data: Manufacturer's product description literature covering components of system.
- B. Shop Drawings: Illustrating materials used as well as scaled plan illustrating system layout.
- C. Samples for Verification: 6 inch square samples of wood panel for verification of custom color.
- D. Installation Instructions: Manufacturer's installation instructions as well as assembly instructions that may be required.

1.3 WARRANTY

- A. Special Warranty: Manufacturer agrees to repair or replace components of shelving assemblies that fail in materials or workmanship within specified warranty period.
1. Warranty Period: 1 year from date of Substantial Completion.

PART 2 - PRODUCTS

2.1 MANUFACTURED UNITS

- A. Ventilated Wire Shelving System. Shelving system consisting of vinyl- coated steel rods and accessories.
1. Manufacturers: Subject to compliance with requirements, provide products from one of the following:
 - a. ClosetMaid LLC: ShelfTrack Shelf Kit.
 - b. elfa: elfa Ventilated Shelving System.
 - c. Organized Living, Inc.: Lifetime Ventilated Wire System.
 - d. Rubbermaid Incorporated: Direct Mount Closet System.
 - e. WoodTrac; a division of Sauder Woodworking Co.: WireTrac Ventilated Wire System.
 - f. Approved substitution.
 2. Size: 12 inch deep by lengths indicated on Drawings.
 3. Color: White.
 4. Shelves: Provide style with open rod that allows hangers to slide entire length.
 5. Include shelf supports and brackets, corner brackets, end brackets, poles, end caps, and other items for a complete installation.
 6. Fasteners: Size and length as required by shelving manufacturer.

2.2 ACCESSORIES

- A. Mounting Screws: Provide bracket screws to allow for height adjustment. Size and length as required by shelving manufacturer.
- B. Hangers: Manufacturer's hangers spaced 4 per foot.

PART 3 - EXECUTION

3.1 EXAMINATION

- A. Verify that conditions will allow for installation of shelving.
- B. Verify that wood blocking is installed and ready to receive units.
- C. Verify length of each space where shelving systems are scheduled.

3.2 INSTALLATION

- A. Erect and install shelving units as per Manufacturer's recommendations.
- B. Install units plumb.
- C. Screw units back to back or to wall, depending on location.

3.3 CLEANING AND ADJUSTING

- A. Clean units prior to final inspection.

3.4 PROTECTION

- A. Protect units from damage that may be caused by Work of others.

3.5 SCHEDULES

- A. Depth, quantity, and location of units are indicated on Drawings.

END OF SECTION 105700

SECTION 113013
RESIDENTIAL APPLIANCES

PART 1 - GENERAL

1.1 SUMMARY

- A. Section Includes:
 - 1. Cooking appliances.
 - 2. Kitchen exhaust ventilation.
 - 3. Refrigeration appliances.
 - 4. Cleaning appliances.

1.2 ADMINISTRATIVE REQUIREMENTS

- A. Preinstallation Meeting: Conduct meeting at Project site.

1.3 ACTION SUBMITTALS

- A. Product Data: For each type of product.
 - 1. Include installation details, material descriptions, dimensions of individual components, and finishes for each appliance.
 - 2. Include rated capacities, operating characteristics, electrical characteristics, and furnished accessories.
- B. Sustainable Design Submittals:
 - 1. ENERGY STAR: Product Data for indicated products, showing compliance with requirements for ENERGY STAR product labeling.
- C. Samples: For each exposed product and for each color and texture specified, in manufacturer's standard size.
- D. Product Schedule: For appliances. Use same designations indicated on Drawings.

1.4 INFORMATIONAL SUBMITTALS

- A. Qualification Data: For manufacturer, from manufacturer.
- B. Product Certificates: For each type of appliance.
- C. Sample Warranties: For manufacturers' special warranties.

1.5 CLOSEOUT SUBMITTALS

- A. Operation and Maintenance Data: For each residential appliance to include in operation and maintenance manuals.

1.6 QUALITY ASSURANCE

- A. Manufacturer Qualifications: Maintains, within 25 miles of Project site, a service center capable of providing training, parts, and emergency maintenance repairs.

1.7 WARRANTY

- A. Special Warranties: Manufacturer agrees to repair or replace residential appliances or components that fail in materials or workmanship within specified warranty period except as qualified below:
 - 1. Warranty Period: 2 years from date of Substantial Completion.
 - 2. Provide manufacturer's standard written limited 1 year warranty for each type of appliance specified.
 - 3. Provide manufacturer's standard written limited parts warranty for each type of appliance specified.

PART 2 - PRODUCTS

2.1 MANUFACTURERS

- A. Source Limitations: Obtain residential appliances from single source and each type of residential appliance from single manufacturer, unless indicated otherwise.

2.2 PERFORMANCE CRITERIA

- A. Electrical Appliances: Listed and labeled as defined in NFPA 70, by a qualified testing agency, and marked for intended location and application.
- B. Accessibility: Where residential appliances are indicated to comply with accessibility requirements, comply with applicable provisions in the DOJ's 2010 ADA Standards for Accessible Design and ICC A117.1.

2.3 APPLIANCES

- A. Refer to Appliance Legend on Drawings and Owner's design standards for manufacturers, model numbers, and finishes.
- B. Provide the following appliances at each unit unless indicated otherwise:
 - 1. Refrigerator.
 - 2. Electric range, 30-inch, 4-burner.
 - 3. Range hood.
 - 4. Dishwasher, 24 inch.
 - 5. Washer and dryer.
 - 6. Disposal.
 - 7. Microwave
- C. Provide the following at Type A Units:
 - 1. Restricted clearance dishwashers for installation under 34 inch high countertops.
 - 2. Ranges with front panel mounted controls.
 - 3. Range hood control switch on wall at or below maximum height of 42 inches above finish floor.

2.4 GENERAL FINISH REQUIREMENTS

- A. Protect mechanical finishes on exposed surfaces from damage by applying a strippable, temporary protective covering before shipping.
- B. Appearance of Finished Work: Noticeable variations in same piece are not acceptable. Variations in appearance of adjoining components are acceptable if they are within range of approved Samples and are assembled or installed to minimize contrast.

PART 3 - EXECUTION

3.1 EXAMINATION

- A. Examine substrates, areas, and conditions, with Installer present, for compliance with requirements for installation tolerances, power connections, and other conditions affecting installation and performance of residential appliances.
- B. Examine roughing-in for piping systems to verify actual locations of piping connections before appliance installation.
- C. Examine walls, ceilings, and roofs for suitable conditions where overhead exhaust hoods will be installed.
- D. Prepare written report, endorsed by Installer, listing conditions detrimental to performance of Work.
- E. Proceed with installation only after unsatisfactory conditions have been corrected.

3.2 INSTALLATION

- A. Install appliances according to manufacturer's written instructions.
- B. Built-in Equipment: Securely anchor units to supporting cabinets or countertops with concealed fasteners. Verify that clearances are adequate for proper functioning and that rough openings are completely concealed.
- C. Freestanding Equipment: Place units in final locations after finishes have been completed in each area. Verify that clearances are adequate to properly operate equipment.
- D. Range Anti-Tip Device: Install at each range according to manufacturer's written instructions.

3.3 FIELD QUALITY CONTROL

- A. Perform the following tests and inspections:
 - 1. Perform visual, mechanical, and electrical inspection and testing for each appliance according to manufacturers' written recommendations. Certify compliance with each manufacturer's appliance-performance parameters.
 - 2. Leak Test: After installation, test for leaks. Repair leaks and retest until no leaks exist.
 - 3. Operational Test: After installation, start units to confirm proper operation.
 - 4. Test and adjust controls and safeties. Replace damaged and malfunctioning controls and components.
- B. An appliance will be considered defective if it does not pass tests and inspections.
- C. Prepare test and inspection reports.

3.4 DEMONSTRATION

- A. Engage a factory-authorized service representative to train Owner's maintenance personnel to adjust, operate, and maintain residential appliances.

END OF SECTION 113013

SECTION 116800
PLAY FIELD EQUIPMENT AND STRUCTURES

PART 1 - GENERAL

1.1 SUMMARY

- A. Section includes playground equipment as follows:
 - 1. Freestanding playground equipment.
 - 2. Composite playground equipment.

1.2 DEFINITIONS

- A. Definitions in ASTM F 1487 apply to Work of this Section.
- B. IPEMA: International Play Equipment Manufacturers Association.

1.3 ADMINISTRATIVE REQUIREMENTS

- A. Preinstallation Meeting: Conduct meeting at Project site.

1.4 ACTION SUBMITTALS

- A. Product Data: For each type of product.
- B. Sustainable Design Submittals:
 - 1. Chain-of-Custody Certificates: For certified wood products. Include statement of costs.
 - 2. Chain-of-Custody Qualification Data: For manufacturer and vendor.
- C. Shop Drawings: For each type of playground equipment.
 - 1. Include plans, elevations, sections, and attachment details.
 - 2. Include fall heights and use zones for playground equipment, coordinated with the critical-height values of protective surfacing specified in Section 321816.13 – Playground Protective Surfacing.
- D. Samples for Verification: For each type of exposed finish on the following products:
 - 1. Include Samples of accessories to verify color and finish selection.
 - 2. Posts and Rails: Minimum 6 inches long.
 - 3. Platforms: Minimum 6 inches square.
 - 4. Molded Plastic: Minimum 3 inches square.

1.5 INFORMATIONAL SUBMITTALS

- A. Qualification Data: For Installer.
- B. Product Certificates: For each type of playground equipment.
- C. Material Certificates: For the following items:
 - 1. Shop finishes.
 - 2. **[Wood-Preservative Treatment: Include certification by treating plant that states type of preservative solution and pressure process used, net amount of preservative retained, and compliance with applicable standards.]**
- D. Field quality-control reports.
- E. Sample Warranty: For manufacturer's special warranties.

1.6 CLOSEOUT SUBMITTALS

- A. Maintenance Data: For playground equipment and finishes to include in maintenance manuals.

1.7 QUALITY ASSURANCE

- A. Manufacturer Qualifications: A firm whose playground equipment components have been certified by IPEMA's third-party product certification service.
- B. Manufacturer Qualifications: A qualified manufacturer that is certified for chain of custody by an FSC-accredited certification body.
- C. Vendor Qualifications: A vendor that is certified for chain of custody by an FSC-accredited certification body.
- D. Installer Qualifications: An entity that employs installers and supervisors who are trained and approved by manufacturer.

1.8 WARRANTY

- A. Special Warranty: Manufacturer agrees to repair or replace components of playground equipment that fail in materials or workmanship within specified warranty period.
 - 1. Failures include the following:
 - a. Structural failures.
 - b. Deterioration of metals, metal finishes, and other materials beyond normal weathering and use.
 - 2. Warranty Period: **[2] [5]** years from date of Substantial Completion.

PART 2 - PRODUCTS

2.1 MANUFACTURERS

- A. Source Limitations: Obtain playground equipment from single source from single manufacturer.
- B. Playground equipment and components shall have IPEMA Certification Seal.
- C. The following playground equipment and components shall have IPEMA Certification Seal:
 - 1. **<Insert playground equipment or component>**.

2.2 PERFORMANCE CRITERIA

- A. Safety Standard: Provide playground equipment according to ASTM F 1487.

2.3 FREESTANDING PLAYGROUND EQUIPMENT

- A. Swing Set: **[Traditional style with tripod angled legs] [Contemporary style with vertical bipod arches] [Contemporary style with single-post legs] [Contemporary T-style]** providing upright support.
 - 1. [<Double click here to find, evaluate, and insert list of manufacturers and products.>](#)
 - 2. Metal Frame: **[Galvanized-steel] [Aluminum]** pipe or tubing.
 - a. Leg Upright(s): Not less than **[1-7/8 inch] [2-3/8 inch] [3-1/2 inch] [4-1/2 inch] [5 inch]** OD.
 - b. Overhead Beam: **[Match leg upright] [Not less than 2-3/8 inch] [Not less than 3-1/2 inch]** OD.
 - c. Color: As selected by Architect from manufacturer's full range.
 - 3. Wood Frame: Leg upright(s) and overhead beam not less than **[4 inches square] [6 inches square] [6 inches round]** or larger.

4. Overhead Beam Height: [96 inches] [10 ft.] [Height as indicated on Drawings] from pivot point to protective surfacing below.
 5. Suspension Members: [Standard link chain] [Short link chain not permitting finger penetration] [Cable] [Manufacturer's standard].
 - a. Color: As selected by Architect from manufacturer's full range.
 6. Swing Connector: [S-hook] [Double clevis and bolt link].
 7. Swing Hanger: Galvanized [stamped steel clamp and ductile-iron pivot] [heavy-duty ductile iron] [manufacturer's standard].
 8. Swing Seats: [Enclosed, full-bucket infant/tot] [Half-bucket] [U-shaped flexible belt] [Rigid rectangular] [Rigid disk] [Tire] seat made from [rubber] [plastic].
 - a. Color: As selected by Architect from manufacturer's full range.
 9. Capacity: [1] [2] [3] swing(s).
 10. Age Appropriateness: [2 through 5 years] [5 through 12 years].
- B. Slide: [Single] [Double-side-by-side] [Double-diverging] descending chute(s)[, traditional style].
1. [<Double click here to find, evaluate, and insert list of manufacturers and products.>](#)
 2. Plan Configuration: [Straight-aligned] [Quarter-turn] [Half-turn] [3-quarter-turn] [Full-turn spiral] [S-shaped] chute(s).
 3. Access: [Stair or stepladder with handrails] [Vertical ladder] [Vertical ladder with side handrails].
 4. Sit-Down Entrance: With [protective barriers] [opaque plastic panel barriers] [canopy or hood enclosure] and overhead [handhold] [and side handholds].
 5. Frame: Manufacturer's standard [galvanized-steel pipe or tubing] [aluminum pipe or tubing] [wood].
 6. Sliding Surface: [Inclined] [Wavy] [Washboard rollers].
 7. Sliding Surface Construction: [Flat, continuous stainless-steel sheet with integral, full-length side rails] [U-shaped, continuous stainless-steel sheet with integral, full-length side rails] [One-piece plastic with integral, full-length side rails] [Plastic tube, ID not less than 24 inches] [Plastic tube, ID not less than 30 inches].
 - a. Color: As selected by Architect from manufacturer's full range.
 8. Age Appropriateness: [2 through 5 years] [5 through 12 years].
- C. Tunnel (Crawl Tube): Freestanding, [straight-aligned] [quarter-turn] [half-turn] [S-shaped] [zigzag] [wavy] [inclined] configuration.
1. [<Double click here to find, evaluate, and insert list of manufacturers and products.>](#)
 2. Material: [Plastic tube, ID not less than 24 inches] [Plastic tube, ID not less than 30 inches].
 - a. Color: As selected by Architect from manufacturer's full range.
- D. Climber: [Arch] [Tower] [Dome] [Overhead horizontal ladder] [Overhead pole] [Flexible cable net] [Flexible chain net] [Vertical ladder] [Vertical panel wall].
1. [<Double click here to find, evaluate, and insert list of manufacturers and products.>](#)
 2. Frame: Manufacturer's standard [galvanized-steel pipe or tubing] [aluminum pipe or tubing] [wood].
 3. Accessories:
 - a. Sliding Pole(s): [1] [2] [3] [4].
 - b. Handhold rings.
 - c. Color: As selected by Architect from manufacturer's full range.
 4. Capacity: [5] [10] users.
 5. Age Appropriateness: [2 through 5 5] [5 through 12 years].
- E. Merry-Go-Round or Whirl: Rotating [platform] [seating] [hang bars] around a vertical axis.
1. [<Double click here to find, evaluate, and insert list of manufacturers and products.>](#)
 2. Rotating Mechanism: Permanently sealed and lubricated ball bearings with [hydraulic] [or] [mechanical] speed-limiting device.

3. Platform: Round, **[dish-shaped] [flat] [flat, dimpled]** steel sheet, not less than 0.12 inch nominal thickness, with slip-resistant footing.
 - a. Color: As selected by Architect from manufacturer's full range.
 4. Handholds and Handrails: Metal pipe or tubing.
 - a. Color: As selected by Architect from manufacturer's full range.
 5. Capacity: **[Single] [2] [5]** user(s).
 6. Age Appropriateness: **[2 through 5 years] [5 through 12 years]**.
- F. Rocking/Springing Equipment: **[Rocking rider] [Rocking platform] [Seesaw]**.
1. [<Double click here to find, evaluate, and insert list of manufacturers and products.>](#)
 2. Seat(s): **[Cast aluminum] [Molded plastic] [or] [Wood][; with handholds] [; with handholds and footrests]**.
 - a. Seat Style: **[Animal] [Automobile]**.
 - b. Color: As selected by Architect from manufacturer's full range.
 3. Multiple Seating and Standing Platform: Manufacturer's standard platform with slip-resistant finish.
 - a. Color: As selected by Architect from manufacturer's full range.
 4. Frame: **[Galvanized-steel pipe or tubing] [Aluminum pipe or tubing] [or] [wood]** and **[one] [or] [2]** coil spring(s); 2 or more steel springs with steel base plate.
 - a. Color: As selected by Architect from manufacturer's full range.
 5. Capacity: **[Single] [2]** user(s).
 6. Age Appropriateness: **[2 through 5 years] [5 through 12 years]**.

2.4 COMPOSITE PLAYGROUND EQUIPMENT

- A. Composite Play Structure: Integral play assembly that provides more than 1 play activity; manufactured as a system or assembled from manufacturer's standard modular-sized units.
1. [<Double click here to find, evaluate, and insert list of manufacturers and products.>](#)
 2. Metal Frame: **[Galvanized-steel] [Aluminum]** pipe or tubing connected with **[bolts] [or] [clamps]**.
 - a. Main Frame Posts: Not less than **[4 inch] [5 inch] [6 inch]** OD.
 - b. Color: As selected by Architect from manufacturer's full range.
 3. Wood Frame: Frame components connected with bolts.
 - a. Main Frame Posts: Not less than **[4 inches square] [6 inches square] [6 inches round]**.
 - b. Color: As selected by Architect from manufacturer's full range.
 4. Platforms: **[Perforated metal] [Wood] [Plastic] [Manufacturer's standard]**.
 - a. Color: As selected by Architect from manufacturer's full range.
 5. Roofs: **[Perforated metal] [Plastic] [Wood] [Manufacturer's standard]**.
 - a. Color: As selected by Architect from manufacturer's full range.
 6. Play Structure Access Component(s): **[Ladder] [Stepladder] [Stairs] [Ramp] [Accessible crawl ramp] [Accessible transfer platform]**.
 - a. Handholds: **[Protective barriers] [Guardrails] [Handrails] [Handholds][on each side]**.
 7. Equipment: Include the following play event components:
 - a. Activity panel.
 - b. Balance beam.
 - c. Bridge.
 - d. Climber: **[Overhead horizontal ladder] [Vertical ladder] [Flexible net] [Panel] [Pole]**.
 - e. Log roll.
 - f. Slide.
 - g. Track ride.
 - h. Tunnel.
 - i. Color: As selected by Architect from manufacturer's full range.
 8. Arrangement: **[As indicated on Drawings] [Manufacturer's standard]**.

9. Capacity: **[10] [20]** users.
10. Age Appropriateness: **[2 through 5 years] [5 through 12 years]**.

2.5 FABRICATION

- A. Provide sizes, strengths, thicknesses, wall thickness, and weights of components as required to comply with requirements in ASTM F 1487. Factory drill components for field assembly. Unnecessary holes in components, not required for field assembly, are not permitted. Provide complete play structures, including supporting members and connections, means of access and egress, designated play surfaces, barriers, guardrails, handrails, handholds, and other components indicated or required for equipment indicated.
- B. Metal Frame: Fabricate main-frame upright support posts from metal pipe or tubing with cross-section profile and dimensions as required. Unless otherwise indicated, provide each pipe or tubing main-frame member with manufacturer's standard drainable bottom plate or support flange. Fabricate secondary frame members, bracing, and connections from either steel or aluminum.
- C. Wood Frame: Fabricate main-frame upright support posts from wood. Fabricate secondary frame members, bracing, and connections from wood, steel, or aluminum.
- D. Composite Frame: Fabricate main-frame upright support posts from metal and plastic. Fabricate secondary frame members, bracing, and connections from either steel or aluminum.
- E. Play Surfaces: Manufacturer's standard elevated drainable decks, platforms, landings, walkways, ramps, and similar transitional play surfaces, designed to withstand loads; fabricated from **[perforated or expanded metal] [molded plastic] [plastic panel or plank] [polyethylene panel or plank] [wood plank]** made into floor units with slip-resistant finish. Fabricate units in modular sizes and shapes to form assembled play surfaces indicated.
- F. Protective Barriers: Fabricate according to ASTM F 1487. Extend barriers to height above the protected elevated surface according to requirements for use by age group indicated. Fabricate from **[one or more of]** the following:
 1. Welded-metal pipe or tubing with vertical bars.
 2. Steel sheet with openings for vision and ventilation.
 3. Metal-pipe or -tubing frame with wire-mesh infill panels.
 4. **[Opaque] [Transparent]** plastic panels **[with openings]**.
 5. Vertical wood balusters with metal pipe or tubing or wood frame.
 6. Wood panels with openings for vision and ventilation.
- G. Guardrails: Provide guardrails configured to completely surround the protected area, except for access openings. Fabricate from **[welded metal pipe or tubing] [metal pipe or tubing, and wood]**. Extend guardrails according to requirements for use by age group indicated.
- H. Handrails: Welded metal pipe or tubing, maximum OD **[between 0.95 and 1.55 inches] [of 0.125 inch]**.
 1. Provide handrails at heights to comply with requirements for use by age group indicated according to ASTM F 1487.
- I. Roofs and Canopies: Designed to discourage and minimize climbing by users.
 1. Fabricated from **[metal] [metal-pipe or -tubing-framed welded wire] [opaque plastic] [clear polycarbonate plastic] [polyethylene] [or] [wood]**.
- J. Signs: Manufacturer's standard sign panels, fabricated from **[opaque plastic with graphics molded in] [wood with painted graphics]**, attached **[to freestanding, upright support posts] [or] [directly to playground equipment]**.
 1. Text: Minimum informational content according to ASTM F 1487.
 2. Color: As selected by Architect from manufacturer's full range.

2.6 MATERIALS

- A. Aluminum: Material, alloy, and temper recommended by manufacturer for type of use and finish indicated.
- B. Steel: Material types, alloys, and forms recommended by manufacturer for type of use and finish indicated[, **hot-dip galvanized**].
- C. Stainless-Steel Sheet: Type 304; finished on exposed faces with No. 2B finish.
- D. Wood: [**Douglas fir, preservative treated after fabrication**] [**Pine, preservative treated after fabrication**] [**Western red cedar**], surfaced smooth on all sides and all edges rounded.
- E. Certified Wood: Wood products shall be certified as "FSC Pure" according to FSC STD-01-001 and FSC STD-40-004.
- F. Plywood: PS 1, Exterior grade; smooth surfaced with rounded edges[; **preservative treated after fabrication**].
- G. Opaque Plastics: Color impregnated, UV stabilized, and mold resistant.
- H. Transparent Plastic: Abrasion-resistant, UV-stabilized polycarbonate sheet; clear, colorless; not less than 3/16 inch thick.
- I. Suspension Chain and Fittings: ASTM A 467, Class CS, 4/0 or 5/0, welded-straight-link coil chain; [**hot-dip galvanized**] [**zinc plated**] [**or**] [**PVC coated**]; with commercial-quality, [**hot-dip galvanized**] [**or**] [**zinc-plated**] steel connectors and swing or ring hangers.
- J. Suspension Cable: Manufacturer's standard [**hot-dip galvanized**] [**zinc-plated**] [**or**] [**PVC-coated**] cable; with commercial-quality, [**hot-dip galvanized**] [**or**] [**zinc-plated**] steel connectors and swing or ring hangers.
- K. Iron Castings and Hangers: Malleable iron, ASTM A 47, Grade 32510, hot-dip galvanized.
- L. Post Caps: [**Cast aluminum**] [**or**] [**color-impregnated, UV-stabilized, mold-resistant polyethylene or polypropylene**]; color to match posts.
- M. Platform Clamps and Hangers: [**Cast aluminum**] [**or**] [**zinc-plated steel, not less than 0.105 inch nominal thickness**].
- N. Hardware: Manufacturer's standard; commercial-quality; corrosion-resistant; hot-dip galvanized steel and iron, stainless steel, or aluminum; of a vandal-resistant design.
- O. Fasteners: Manufacturer's standard; corrosion-resistant; hot-dip galvanized or zinc-plated steel and iron, or stainless steel; permanently capped; and theft resistant.

2.7 WOOD-PRESERVATIVE-TREATED MATERIALS

- A. Preservative Treatment: Pressure-treat wood products according to AWPA U1 and the following:
 - 1. Use preservative chemicals acceptable to authorities having jurisdiction and containing no arsenic or chromium. Use chemical formulations that do not bleed through or otherwise adversely affect finishes. Do not use colorants to distinguish treated materials from untreated materials.
 - 2. Kiln-dry lumber and plywood after treatment to a maximum moisture content, respectively, of 19 and 15 percent. Do not use materials that are warped or do not comply with requirements for untreated materials.

2.8 CAST-IN-PLACE CONCRETE

- A. Concrete Materials and Properties: Comply with requirements in Section 033000 – Cast-in-Place Concrete and ACI 301/ for normal-weight, air-entrained concrete with minimum 28 day compressive strength of 3,000 psi, 3 inch slump, and 1 inch maximum-size aggregate.
- B. Concrete Materials and Properties: Dry-packaged concrete mix complying with ASTM C 387 and mixed at site with potable water, according to manufacturer's written instructions, for normal-weight concrete with minimum 28-day compressive strength of 3,000 psi, 3 inch slump, and 1 inch maximum-size aggregate.

2.9 ALUMINUM FINISHES

- A. Baked-Enamel or Powder-Coat Finish: Minimum dry film thickness of 1.5 mils, medium gloss. Comply with coating manufacturer's written instructions for cleaning, conversion coating, and applying and baking finish.
- B. PVC Finish: UV-stabilized, mold-resistant, slip-resistant, matte-textured, dipped or sprayed-on PVC finish, with flame retardant added, and with minimum dry film thickness of 80 mils. Comply with coating manufacturer's written instructions for pretreatment and application.

2.10 IRON AND STEEL FINISHES

- A. Baked-Enamel or Powder-Coat Finish: After cleaning and pretreating, apply manufacturer's standard 2-coat, baked-on finish consisting of prime coat and thermosetting topcoat to a minimum dry film thickness of 2 mils. Comply with coating manufacturer's written instructions for pretreatment, applying, and baking.
- B. PVC Finish: UV-stabilized, mold-resistant, slip-resistant, matte-textured, dipped or sprayed-on PVC finish, with flame retardant added, and with minimum dry film thickness of 80 mils [**100 mils**]. Comply with coating manufacturer's written instructions for pretreatment and application.

2.11 STAINLESS-STEEL FINISHES

- A. Surface Preparation: Remove tool and die marks and stretch lines, or blend into finish.
- B. Bright, Cold-Rolled, Unpolished Finish: No. 2B.

PART 3 - EXECUTION

3.1 EXAMINATION

- A. Examine substrates, areas, and conditions, with Installer present, for compliance with requirements for earthwork, subgrade elevations, surface and subgrade drainage, and other conditions affecting performance of Work.
 - 1. Do not begin installation before final grading required for placing playground equipment and protective surfacing is completed.
- B. Proceed with installation only after unsatisfactory conditions have been corrected.

3.2 INSTALLATION

- A. Comply with manufacturer's written installation instructions for each equipment type unless more stringent requirements are indicated. Anchor playground equipment securely, positioned at locations and elevations indicated.
 - 1. Maximum Equipment Height: Coordinate installed fall heights of equipment with finished elevations and critical-height values of protective surfacing. Set equipment so fall heights and

elevation requirements for age group use and accessibility are within required limits. Verify that playground equipment elevations comply with requirements for each type and component of equipment.

- B. Post and Footing Excavation: Excavate holes for posts and footings as indicated in firm, undisturbed or compacted subgrade soil.
- C. Post Set on Subgrade: Level bearing surfaces with drainage fill to required elevation.
- D. Post Set with Concrete Footing: Comply with Section 033000 – Cast-in-Place Concrete and ACI 301 for measuring, batching, mixing, transporting, forming, and placing concrete.
 - 1. Set equipment posts **[in] [on]** concrete footing. Protect portion of posts above footing from concrete splatter. Verify that posts are set plumb or at the correct angle, alignment, height, and spacing.
 - a. Place concrete around posts and vibrate or tamp for consolidation. Hold posts in position during placement and finishing operations until concrete is sufficiently cured.
 - 2. Embedded Items: Follow equipment manufacturer's written instructions and drawings to ensure correct installation of anchorages for equipment.
 - 3. Finishing Footings: Smooth top, and shape to shed water.

3.3 FIELD QUALITY CONTROL

- A. Testing Agency: Owner will engage a qualified testing agency to perform tests and inspections.
- B. Playground equipment items will be considered defective if they do not pass tests and inspections.
- C. Prepare test and inspection reports.
- D. Notify Architect and Owner 48 hours in advance of dates and times of testing and inspection.

END OF SECTION 116800

SECTION 120513

FABRICS

PART 1 - GENERAL

1.1 SUMMARY

- A. Section Includes:
 - 1. Abrasion, mildew, and bacteria resistant upholstery fabrics.
- B. Related Sections:
 - 1. Section 064023 – Interior Architectural Woodwork.
 - 2. Section 064100 – Architectural Wood Casework.

1.2 ACTION SUBMITTALS

- A. Product Data: Indicate product description and compliance with specified performance requirements.
- B. Samples: Two 8 inch square pieces of each fabric type specified for material verification.

1.3 INFORMATIONAL SUBMITTALS

- A. Maintenance Data: Include recommendations for cleaning and stain removal methods, and cleaning materials.

1.4 DELIVERY, STORAGE, AND HANDLING

- A. Do not deliver upholstery fabrics to Project site until areas are ready for installation.
- B. Inspect materials upon delivery to assure that specified products have been received.
- C. Store indoors prior to installation.
- D. Handle materials to prevent damage. Provide protective coverings to prevent physical damage or staining following installation for duration of Project.

PART 2 - PRODUCTS

2.1 MANUFACTURERS

- A. Basis-of-Design Product: Subject to compliance with requirements, provide specified products from Arc-Com Fabrics, Inc. or approved substitution from one of the following manufacturers:
 - 1. Architex International.
 - 2. CF Stinson.
 - 3. DesignTex; a Steelcase Company.
 - 4. Gilfor, Inc.
 - 5. Knoll, Inc. KnollTextiles
 - 6. Maharam.
 - 7. Momenturm Textiles.

2.2 MATERIALS

- A. Fabric Products: As indicated on Interior Finish Schedule [**Legend**] on Drawings.

PART 3 - EXECUTION

3.1 INSTALLATION

- A. Fabricate items as indicated on Drawings.

3.2 CLEANING

- A. Remove ordinary dirt and smudges with soap and water, or other methods recommended by material manufacturer. Dry with soft, lint-free cloth or towel.
- B. Remove difficult stains using strong detergent following detergent manufacturer's instructions.
- C. Clean site of debris and unused materials and remove from site.

3.3 PROTECTION

- A. Protect installed fabrics from damage and soiling during remainder of construction activities until Substantial Completion.

END OF SECTION 120513

SECTION 122116
VERTICAL LOUVER BLINDS

PART 1 - GENERAL

1.1 SUMMARY

- A. Section Includes:
 - 1. Vertical louver blinds with **[aluminum]** **[PVC]** vanes.

1.2 ACTION SUBMITTALS

- A. Product Data: For each type of product.
- B. Shop Drawings: For vertical louver blinds, include fabrication and installation details.
- C. Samples for Initial Selection: For each type of vertical louver blind.
 - 1. Include Samples of accessories involving color selection.
- D. Samples for Verification: For each type of vertical louver blind.
 - 1. Vane: Not less than 12 inches long.
 - 2. Vertical Louver Blind: Full-size unit, not less than 36 inches wide by 36 inches long.
 - 3. Valance: Full-size unit, not less than 12 inches wide.
- E. Product Schedule: For vertical louver blinds. Use same designations indicated on Drawings.

1.3 INFORMATIONAL SUBMITTALS

- A. Product Test Reports: For vertical louver blinds with polymer vanes that have been tested for compliance with NFPA 701 for tests performed by manufacturer and witnessed by a qualified testing agency.

1.4 CLOSEOUT SUBMITTALS

- A. Maintenance Data: For vertical louver blinds to include in maintenance manuals.

1.5 MAINTENANCE MATERIAL SUBMITTALS

- A. Furnish extra materials, from the same product run, that match products installed and that are packaged with protective covering for storage and identified with labels describing contents.
 - 1. Vertical Louver Blinds: Full-size units equal to 5 percent of quantity installed for each size, color, texture, pattern, and finish indicated, but no fewer than 2 units.
 - 2. Vanes: Furnish quantity of full-size units equal to 5 percent of quantity installed for each type, size, texture, pattern, and finish indicated, but no fewer than 2 units.

1.6 QUALITY ASSURANCE

- A. Mockups: Build mockups to verify selections made under Sample submittals, to demonstrate aesthetic effects, and to set quality standards for fabrication and installation.
 - 1. Approval of mockups does not constitute approval of deviations from Contract Documents contained in mockups unless Architect specifically approves such deviations in writing.
 - 2. Subject to compliance with requirements, approved mockups may become part of completed Work if undisturbed at time of Substantial Completion.

1.7 DELIVERY, STORAGE, AND HANDLING

- A. Deliver vertical louver blinds in factory packages, marked with manufacturer and product name, and location of installation using same designations indicated on Drawings.

1.8 FIELD CONDITIONS

- A. Environmental Limitations: Do not install vertical louver blinds until construction and we2rk and finish Work in spaces, including painting, is complete and dry and ambient temperature and humidity conditions are maintained at levels indicated for Project when occupied for its intended use.
- B. Field Measurements: Where vertical louver blinds are indicated to fit to other construction, verify dimensions of other construction by field measurements before fabrication and indicate measurements on Shop Drawings. Allow clearances for operating hardware of operable glazed units through entire operating range. Notify Architect of installation conditions that vary from Drawings. Coordinate fabrication schedule with construction progress to avoid delaying Work.

PART 2 - PRODUCTS

2.1 MANUFACTURERS

- A. Source Limitations: Obtain vertical louver blinds from single source from single manufacturer.

2.2 VERTICAL LOUVER BLINDS, PVC VANES

- A. Vanes: Lead-free, UV-stabilized, integrally colored, opaque, permanently flexible, extruded PVC that will not crack or yellow; with not less than 3/8-inch overlap when vanes are rotated fully closed.
 - 1. Width: **[2 inches] [3-1/2 inches]**.
 - 2. Profile: **[Flat] [Crowned] [Narrow-ridged flat] [Narrow-ridged crowned] [Wide-ridged crowned] [Embossed] [S-shaped]**.
 - 3. Perforated Vanes: Openness factor of **[3] [6] [8] [10] [12]** percent.
 - 4. Flame-Resistance Rating: Comply with NFPA 701; testing by a qualified testing agency. Identify products with appropriate markings of applicable testing agency.
 - 5. Features:
 - a. Bottom chain.
- B. Headrail: Channel, formed steel or extruded aluminum with long edges returned or rolled and ends capped. Headrail encloses operating mechanisms including carrier-spacing mechanism that provides uniform vane spacing when blinds are traversed fully across headrail (closed).
 - 1. Manual Traverse Control: **[Nickel-plated, metal bead chain] [Cord] [Wand]**.
 - 2. Manual Rotation Control: **[Nickel-plated, metal bead chain] [Plastic bead chain] [Wand] [Automatic rotation mechanically activated by traverse control]**.
 - 3. Manual Control Locations: **[Right] [Left] [As indicated on Drawings]**.
 - 4. Draw and Stack: **[1 way, stack left] [1 way, stack right] [2 way, center split] [2 way, center stack] [As indicated on Drawings]**.
 - 5. Stack Release: Permitting stacked vanes to be moved away from stacking position for access to glazed opening.
 - 6. Cord-Tensioner Mounting: As indicated on Drawings.
- C. Carriers: Engineered plastic with gears to align and synchronize vane rotation and stems that allow vane removal and replacement. Lead carriers have self-lubricating wheels or elongated bearing surfaces; remaining carriers have self-lubricating wheels.
- D. Valance: Manufacturer's standard with vane insert.

- E. Mounting Brackets: With spacers and shims required for blind placement and alignment indicated.
 - 1. Type: **[Wall] [Overhead] [For headrail recessed in pocket] [As indicated]**.
 - 2. Intermediate Support: Provide intermediate support brackets to produce support spacing recommended by blind manufacturer for weight and size of blind.
- F. Colors, Textures, and Patterns:
 - 1. Vanes: As indicated on Drawings.
 - 2. Components: Provide materials exposed to view matching or coordinating with vanes unless otherwise indicated.

2.3 VERTICAL LOUVER BLIND FABRICATION

- A. Product Safety Standard: Fabricate vertical louver blinds to comply with WCMA A 100.1 including requirements for corded, flexible, looped devices; lead content of components; and warning labels.
- B. Unit Sizes: Fabricate units in sizes to cover window and other openings as follows, measured at 74 deg F:
 - 1. Between (Inside) Jamb Installation: Width equal to jamb-to-jamb dimension of opening in which blind is installed less 1/4 inch per side or 1/2 inch total, plus or minus 1/8 inch. Length equal to head-to-sill or -floor dimension of opening in which blind is installed less 1/4 inch, plus or minus 1/8 inch.
 - 2. Outside of Jamb Installation: Width and length as indicated, with terminations between blinds of end-to-end installations at centerlines of mullion or other defined vertical separations between openings.
- C. Concealed Components: Noncorrodible or corrosion-resistant-coated materials.
 - 1. Rotation-and-Traverse Mechanisms: With permanently lubricated moving parts.
- D. Installation Brackets: Designed for easy removal and reinstallation of blind, for supporting headrail[, **valance**,] and operating hardware and for bracket positions and blind mounting method indicated.
- E. Installation Fasteners: No fewer than 2 fasteners per bracket, fabricated from metal noncorrosive to brackets and adjoining construction; type designed for securing to supporting substrate; and supporting blinds and accessories under conditions of normal use.
- F. Color-Coated Finish: For metal components exposed to view unless anodized or plated finish is indicated. Apply manufacturer's standard baked finish complying with manufacturer's written instructions for surface preparation including pretreatment, application, baking, and minimum dry film thickness.

PART 3 - EXECUTION

3.1 EXAMINATION

- A. Examine substrates, areas, and conditions, with Installer present, for compliance with requirements for installation tolerances, operational clearances, and other conditions affecting performance of Work.
- B. Proceed with installation only after unsatisfactory conditions have been corrected.

3.2 INSTALLATION

- A. Install vertical louver blinds level and plumb, aligned and centered on openings, and aligned with adjacent units according to manufacturer's written instructions.
 - 1. Locate so exterior vane edges are not closer than 2 inches from interior faces of glass and not closer than 1-1/2 inches from interior faces of glazing frames through full operating ranges of blinds.

2. Install mounting and intermediate brackets to prevent deflection of headrails.
 3. Install with clearances that prevent interference with adjacent blinds, adjacent construction, and operating hardware of glazed openings, other window treatments, and similar building components and furnishings.
- B. Replace damaged vertical louver blinds that cannot be repaired in a manner approved by Architect before time of Substantial Completion.
- 3.3 ADJUSTING
- A. Adjust vertical louver blinds to operate free of binding or malfunction through full operating ranges.
- 3.4 CLEANING
- A. Clean vertical louver blind surfaces after installation according to manufacturer's written instructions.
- 3.5 PROTECTION
- A. Provide final protection and maintain conditions in a manner acceptable to manufacturer and Installer that ensures that vertical louver blinds are without damage or deterioration at time of Substantial Completion.

END OF SECTION 122116

SECTION 123530
RESIDENTIAL CASEWORK

PART 1 - GENERAL

1.1 SUMMARY

- A. Section Includes:
 - 1. Kitchen cabinets.
 - 2. Vanity cabinets.

1.2 DEFINITIONS

- A. Concealed Surfaces of Casework: Surfaces not usually visible after installation, including sleepers, web frames, dust panels, bottoms of drawers, and ends of casework installed directly against and completely concealed by walls or other casework, and tops of wall cabinets and utility cabinets.
- B. Exposed Surfaces of Casework: Surfaces visible when doors and drawers are closed, including visible surfaces in open cabinets or behind glass doors.
- C. Semiexposed Surfaces of Casework: Surfaces behind opaque doors or drawer fronts, including interior faces of doors, interiors and sides of drawers, and bottoms of wall cabinets.

1.3 ADMINISTRATIVE REQUIREMENTS

- A. Coordination:
 - 1. Coordinate layout and installation of blocking and reinforcement in partitions for support of casework.
- B. Preinstallation Meetings: Conduct meeting at Project site.

1.4 ACTION SUBMITTALS

- A. Product Data: For each type of product.
 - 1. Include construction details, material descriptions, dimensions of individual components, and profiles and finishes for casework.
 - 2. Include rated capacities, operating characteristics, profiles, and finishes for hardware.
- B. Sustainable Design Submittals:
 - 1. Environmental Product Declaration (EPD): For each product.
 - 2. Chain-of-Custody Certificates: For certified wood products. Include statement of costs.
 - 3. Chain-of-Custody Qualification Data: For manufacturer and vendor.
 - 4. Laboratory Test Reports: For adhesives, indicating compliance with requirements for low-emitting materials.
 - 5. Laboratory Test Reports: For composite wood products, indicating compliance with requirements for low-emitting materials.
- C. Shop Drawings: For residential casework.
 - 1. Include plans, elevations, details, and attachments to other Work.
 - 2. Show materials, finishes, filler panels, and hardware.
 - 3. Indicate manufacturer's catalog numbers for casework.
- D. Samples for Verification: For the following:
 - 1. Casework Finishes: 8 by 10 inch Samples for each type of casework finish.
 - 2. Hardware: 1 full-size Sample of each type of exposed hardware in each finish required.

1.5 INFORMATIONAL SUBMITTALS

- A. Qualification Data: For manufacturer.
- B. Product Certificates: For casework.

1.6 QUALITY ASSURANCE

- A. Certified Wood: Provide an invoice including vendor's chain-of-custody number, product cost, and entity being invoiced.
- B. Vendor Qualifications: A vendor that is certified for chain of custody by an FSC-accredited certification body.

1.7 FIELD CONDITIONS

- A. Environmental Limitations: Do not deliver or install casework until building is enclosed, wet-Work is complete, and HVAC system is operating and maintaining temperature and relative humidity at levels planned for building occupants during remainder of construction period.
- B. Established Dimensions: Where casework is indicated to fit to other construction, establish dimensions for areas where casework is to fit. Coordinate construction to ensure that actual dimensions correspond to established dimensions. Provide fillers and scribes to allow for trimming and fitting.
- C. Field Measurements: Where casework is indicated to fit to existing construction, verify dimensions of existing construction by field measurements before fabrication and indicate measurements on Shop Drawings. Provide fillers and scribes to allow for trimming and fitting.
- D. Locate concealed framing, blocking, and reinforcements that support casework by field measurements before enclosing them, and indicate measurements on Shop Drawings.

PART 2 - PRODUCTS

2.1 CABINETS

- A. Manufacturers: Subject to compliance with requirements, provide products by one of the following:
 - 1. Lanz Cabinets.
 - 2. Smart Cabinetry LLC.
 - 3. Crown America Intl.
 - 4. Hilton Cabinets.
 - 5. Approved substitution.
- B. Quality Standard: Provide cabinets that comply with KCMA A161.1.
 - 1. KCMA Certification: Provide cabinets with KCMA's "Certified Cabinet" seal affixed in a semiexposed location of each unit and showing compliance with KCMA A161.1.
- C. Certified Wood: Certify wood products as "FSC Pure" in accordance with FSC STD-01-001 and FSC STD-40-004.
- D. Door and Drawer Face Style: Flush overlay; faces cover cabinet fronts.
 - 1. Door and Drawer Fronts: 3/4 inch thick, thermoset decorative panels.
- E. Cabinet Style: Frameless.
 - 1. Face Frames: 5/8 inch thick, thermoset decorative panel material.
- F. Exposed Cabinet End Finish: 3/4 inch thick thermoset decorative panels.

- G. Cabinet End Construction: 1/2 inch thick particleboard with thermally fused, melamine-impregnated decorative paper on interior surfaces.
- H. Cabinet Tops and Bottoms: 5/8 inch thick particleboard.
 - 1. Fully support in rabbets in and secure to end panels and back rail.
 - 2. Where cabinet widths are greater than 24 inches, provide 3/4 inch thick particleboard.
- I. Back, Top, and Bottom Rails: 3/4 by 2-1/2 inch solid wood, interlocking with end panels and rabbeted to receive top and bottom panels. Back rails secured under pressure with glue and with mechanical fasteners.
- J. Wall-Hung-Unit Back Panels: 3/16 inch thick plywood fastened to rear edge of end panels and to top and bottom rails.
- K. Base-Unit Back Panels: 1/4 inch thick hardboard fastened to rear edge of end panels and to top and bottom rails.
- L. Front Frame Drawer Rails: 3/4 by 1-1/4 inch solid wood mortised and fastened into face frame.
- M. Drawers: Fabricate with exposed fronts fastened to subfront with mounting screws from interior of body.
 - 1. Join subfronts, backs, and sides with glued rabbeted joints supplemented by mechanical fasteners.
 - 2. Subfronts, Backs, and Sides: 5/8 inch thick, thermoset decorative particleboard.
 - 3. Bottoms: 1/4 inch thick hardboard.
- N. Shelves: 5/8 inch thick particleboard or 1/2 inch thick plywood.
- O. Joinery: Rabbet backs flush into end panels and secure with concealed mechanical fasteners. Connect tops and bottoms of wall cabinets and bottoms and stretchers of base cabinets to ends and dividers with mechanical fasteners. Rabbet tops, bottoms, and backs into end panels.
- P. Factory Finishing: Finish cabinets at factory.

2.2 CABINET MATERIALS

- A. Composite Wood Products: Verify products are made using ultra-low-emitting formaldehyde resins, as defined in California Air Resources Board's "Airborne Toxic Control Measure to Reduce Formaldehyde Emissions from Composite Wood Products," or are made with no added formaldehyde.
- B. Particleboard: ANSI A208.1, Grade M-2.
 - 1. Recycled Content: Postconsumer recycled content plus 1/2 of preconsumer recycled content not less than 90 percent.
- C. MDF: Medium-density fiberboard, ANSI A208.2, Grade MD.
 - 1. Recycled Content: Postconsumer recycled content plus 1/2 of preconsumer recycled content not less than 90 percent.
- D. Hardboard: ANSI A135.4, Class 1 tempered.
- E. Adhesives: Use adhesives that meet testing and product requirements of California Department of Public Health's "Standard Method for the Testing and Evaluation of Volatile Organic Chemical Emissions from Indoor Sources Using Environmental Chambers."

- F. Exposed Materials:
 - 1. Thermoset Decorative Panels: Particleboard or MDF finished with thermally fused, melamine-impregnated decorative paper.
 - a. Provide material finished on both sides for doors and drawer fronts.
 - b. Provide PVC edge molding on components with exposed or semiexposed edges.
 - c. Color: As indicated on Interior Finish Legend on Drawings.
- G. Semiexposed Materials: Unless otherwise indicated, provide the following:
 - 1. Thermoset Decorative Panels: Particleboard or MDF finished with thermally fused, melamine-impregnated decorative paper.
 - a. Provide material finished on both sides for shelves, dividers, drawer bodies, and other components with 2 semiexposed surfaces.
 - b. Provide PVC edge molding on components with semiexposed edges.
 - c. Colors: As indicated on Interior Finish Legend on Drawings.
- H. Concealed Materials: Particleboard; MDF; or hardboard.

2.3 CABINET HARDWARE

- A. General: Manufacturer's standard units complying with BHMA A156.9, of type, size, style, material, and finish as selected by Architect from manufacturer's full range.
- B. Pulls: As indicated on Interior Finish Legend on Drawings.
- C. Hinges: Concealed European-style, self-closing hinges.
- D. Drawer Guides: Epoxy-coated-metal, self-closing drawer guides; designed to prevent rebound when drawers are closed; with nylon-tired, ball-bearing rollers; and complying with BHMA A156.9, Type B05011 or Type B05091.
- E. Door and Drawer Silencers: Self-adhering, clear, silicone rubber.
 - 1. Doors: Provide 1 silencer at top and bottom of closing edge of each swinging door.
 - 2. Drawers: Provide 1 silencer on back side of drawer front at each corner.

PART 3 - EXECUTION

3.1 EXAMINATION

- A. Examine areas and substrates to receive casework, with Installer present, for conditions under which casework will be installed and for compliance with requirements for installation tolerances, location of framing and reinforcements, and other conditions affecting performance of casework.
- B. Proceed with installation only after unsatisfactory conditions have been corrected.

3.2 PREPARATION

- A. Before installation, condition casework to humidity conditions in installation areas for not less than 72 hours.

3.3 INSTALLATION OF CABINETS

- A. Install casework with no variations in adjoining surfaces; use concealed shims. Where casework abuts other finished Work, scribe and cut for accurate fit. Provide filler strips, scribe strips, and moldings in finish to match casework.
- B. Install casework without distortion so doors and drawers fit the openings, are aligned, and are uniformly spaced. Complete installation of hardware and accessories as indicated.

- C. Install casework level and plumb to a tolerance of 1/8 inch in 8 feet.
 - D. Fastening Casework.
 - 1. Fasten cabinets to adjacent units and to backing
 - 2. Fasten wall cabinets through back, near top and bottom, and at ends not more than 16 inches on center.
 - 3. Provide fasteners of types and sizes as recommended by cabinet manufacture as appropriate for mounting to substrates indicated and for securing specified cabinets and to comply with seismic requirements.
- 3.4 ADJUSTING
- A. Adjust hardware so doors and drawers are centered in openings and operate smoothly without warp or bind. Lubricate operating hardware as recommended by manufacturer.
- 3.5 CLEANING
- A. Clean casework on exposed and semiexposed surfaces. Touch up as required to restore damaged or soiled areas to match original factory finish, as approved by Architect.

END OF SECTION 123530

SECTION 123623.13

PLASTIC-LAMINATE-CLAD COUNTERTOPS

PART 1 - GENERAL

1.1 SUMMARY

- A. Section Includes
 - 1. Plastic-laminate-clad countertops.

1.2 ACTION SUBMITTALS

- A. Product Data: For each type of product.
- B. Sustainable Design Submittals:
 - 1. Environmental Product Declaration (EPD): For each product.
 - 2. Chain-of-Custody Certificates: For certified wood products. Include statement of costs.
 - 3. Laboratory Test Reports: For adhesives, indicating compliance with requirements for low-emitting materials.
 - 4. Product Data: For installation adhesives, indicating VOC content.
 - 5. Laboratory Test Reports: For installation adhesives, indicating compliance with requirements for low-emitting materials.
 - 6. Laboratory Test Reports: For composite wood products, indicating compliance with requirements for low-emitting materials.
- C. Shop Drawings: For plastic-laminate-clad countertops.
 - 1. Include plans, sections, details, and attachments to other Work. Detail fabrication and installation, including field joints.
 - 2. Show locations and sizes of cutouts and holes for items installed in plastic-laminate-clad countertops.
- D. Samples for Verification: As follows:
 - 1. Plastic Laminates: For each type, color, pattern, and surface finish required, 8 by 10 inches in size.
 - 2. Wood-Grain Plastic Laminates: For each type, color, pattern, and surface finish required, 12 by 24 inches in size.
 - 3. Fabrication Sample: For each type and profile of countertop required, provide one sample applied to core material with specified edge material applied to one edge.

1.3 INFORMATIONAL SUBMITTALS

- A. Qualification Data: For fabricator and Installer.
- B. Product Certificates: For the following:
 - 1. Composite wood and agrifiber products.
 - 2. High-pressure decorative laminate.
 - 3. Adhesives.
- C. Quality Standard Compliance Certificates: AWI Quality Certification Program.

1.4 QUALITY ASSURANCE

- A. Fabricator Qualifications: Shop that employs skilled workers who custom fabricate products similar to those required for this Project and whose products have a record of successful in-service performance.
 - 1. Shop Certification: AWI's Quality Certification Program accredited participant.
- B. Installer Qualifications: Fabricator of products and AWI's Quality Certification Program accredited participant.

1.5 DELIVERY, STORAGE, AND HANDLING

- A. Do not deliver countertops until painting and similar operations that could damage countertops have been completed in installation areas.
- B. If countertops must be stored in other than installation areas, store only in areas where environmental conditions comply with requirements specified in "Field Conditions" Article.
- C. Keep surfaces of countertops covered with protective covering during handling and installation.

1.6 FIELD CONDITIONS

- A. Environmental Limitations: Do not deliver or install countertops until building is enclosed, wet-Work is complete, and HVAC system is operating and maintaining temperature and relative humidity at levels planned for building occupants during the remainder of the construction period.
- B. Environmental Limitations: Do not deliver or install countertops until building is enclosed, wet-Work is complete, and HVAC system is operating and maintaining temperature between 60 and 90 deg F and relative humidity between 25 and 55 percent during remainder of construction period.
- C. Field Measurements: Where countertops are indicated to fit to other construction, verify dimensions of other construction by field measurements before fabrication and indicate measurements on Shop Drawings. Coordinate fabrication schedule with construction progress to avoid delaying Work.

PART 2 - PRODUCTS

2.1 FABRICATORS

- A. Fabricators: Subject to compliance with requirements, provide products by one of the following:
 - 1. Advanced Custom Cabinets.
 - 2. Central Cabinet Systems, a division of Frontier Door & Cabinet.
 - 3. Custom Interiors.
 - 4. Genothern.
 - 5. ISEC.
 - 6. Northwest Millwork.
 - 7. Old Mill Cabinets and Millwork.
 - 8. Pacific Cabinets, Inc.
 - 9. Skagit Architectural Millwork.
 - 10. Approved substitutions.
- B. Source Limitations: Firm engaged to assume responsibility for production of architectural wood casework and countertops shall be responsible for the following:
 - 1. Section 062023 – Interior Finish Carpentry.
 - 2. Section 064023 – Interior Architectural Woodwork.
 - 3. Section 064100 – Architectural Wood Casework.

2.2 PLASTIC-LAMINATE-CLAD COUNTERTOPS

- A. Quality Standard: Unless otherwise indicated, comply with "Architectural Woodwork Standards" for grades indicated for construction, finishes, installation, and other requirements.
 - 1. Provide inspections of fabrication and installation together with labels and certificates from AWI certification program indicating that countertops comply with requirements of grades specified.
 - 2. Contract Documents contain requirements that are more stringent than referenced quality standard. Comply with requirements of Contract Documents in addition to those of referenced quality standard.
- B. Grade: Custom.
- C. Certified Wood: Wood products shall be certified as "FSC Pure" according to FSC STD-01-001 and FSC STD-40-004.
- D. High-Pressure Decorative Laminate (HDPL): NEMA LD 3, Grade HGS or as required by woodwork quality standard.
 - 1. Colors, Patterns, and Finishes: See Interior Finish Legend on Drawings for selected decorative plastic-laminate products:
- E. Edge Treatment: Same as laminate cladding on horizontal surfaces unless indicated otherwise.
- F. Core Material: MDF.
- G. Core Material at Sinks: MDF made with exterior glue.
- H. Core Thickness: 3/4 inch or as indicated on Drawings.
 - 1. Build up countertop thickness to 1-1/2 inches at front, back, and ends with additional layers of core material laminated to top where indicated.
- I. Backer Sheet: Provide plastic-laminate backer sheet, NEMA LD 3, Grade BKL, on underside of countertop substrate.
- J. Paper Backing: Provide paper backing on underside of countertop substrate.

2.3 WOOD MATERIALS

- A. Composite Wood and Agrifiber Products: Provide materials that comply with requirements of referenced quality standard for each type of countertop and quality grade specified unless otherwise indicated.
 - 1. Recycled Content of MDF: Postconsumer recycled content plus 1/2 of preconsumer recycled content not less than 90 percent.
 - 2. Composite Wood Products: Products shall be made using ultra-low-emitting formaldehyde resins as defined in California Air Resources Board's "Airborne Toxic Control Measure to Reduce Formaldehyde Emissions from Composite Wood Products" or shall be made with no added formaldehyde.
 - 3. Medium-Density Fiberboard (MDF): ANSI A208.2, Grade 130.
 - a. Products: Subject to compliance with requirements, provide one of the following:
 - 1) ampine; Div. of Timber Products Company: Apex MDF.
 - 2) ARAUCO North America: Trupan Standard MDF.
 - 3) Del-Tin Fiber, LLC: Solidium Ultra MDF.
 - 4) Georgia-Pacific Wood Products LLC: UltraStock Premium MDF.
 - 5) Roseburg Forest Products Co.: Medite II.
 - 6) Timber Products Company: Masisa Ultralight MDF.
 - 7) West Fraser Timber Co., Ltd.: WestPine EcoGold MDF.
 - 8) Weyerhaeuser Company: Super-Refined MDF2.

2.4 ACCESSORIES

- A. Trash Opening Grommets: Stainless steel grommet sets.
 - 1. Manufacturers: Subject to compliance with requirements, provide products from the following:
 - a. Doug Mockett & Company, Inc.
 - b. Approved substitution.
 - 2. (GROM-1): Stainless steel.
 - a. Size: 3-1/2 inch diameter.
 - b. Finish: Satin No. 4.
 - 3. (GROM-2): Trash opening type grommet, stainless steel.
 - a. Size: 6 inch diameter.
 - b. Finish: Satin No. 4.
 - 4. (GROM-3): Trash opening type grommet, stainless steel.
 - a. Size: 8 inch diameter.
 - b. Finish: Satin No. 4.

2.5 MISCELLANEOUS MATERIALS

- A. Adhesives: Use adhesives that meet testing and product requirements of California Department of Public Health's "Standard Method for the Testing and Evaluation of Volatile Organic Chemical Emissions from Indoor Sources Using Environmental Chambers."
- B. Adhesive for Bonding Plastic Laminate: Unpigmented contact cement or selected by fabricator to comply with requirements.
 - 1. Adhesive for Bonding Edges: Hot-melt adhesive or adhesive specified above for faces.
- C. Installation Adhesive:
 - 1. Verify adhesives have a VOC content of 70 g/L or less.
 - 2. Verify adhesives comply with testing and product requirements of California Department of Public Health's "Standard Method for the Testing and Evaluation of Volatile Organic Chemical Emissions from Indoor Sources Using Environmental Chambers."

2.6 FABRICATION

- A. Fabricate countertops to dimensions, profiles, and details indicated. Provide front and end overhang of 1 inch over base cabinets. Ease edges to radius indicated for the following:
- B. Complete fabrication, including assembly, to maximum extent possible before shipment to Project site. Disassemble components only as necessary for shipment and installation. Where necessary for fitting at site, provide ample allowance for scribing, trimming, and fitting.
 - 1. Notify Architect 7 days in advance of dates and times countertop fabrication will be complete.
 - 2. Trial fit assemblies at fabrication shop that cannot be shipped completely assembled. Install dowels, screws, bolted connectors, and other fastening devices that can be removed after trial fitting. Verify that various parts fit as intended, and check measurements of assemblies against field measurements before disassembling for shipment.
- C. Shop cut openings to maximum extent possible to receive appliances, plumbing fixtures, electrical Work, and similar items. Locate openings accurately, and use templates or roughing-in diagrams to produce accurately sized and shaped openings. Sand edges of cutouts to remove splinters and burrs.
 - 1. Seal edges of cutouts by saturating with varnish.

PART 3 - EXECUTION

3.1 PREPARATION

- A. Before installation, condition countertops to average prevailing humidity conditions in installation areas.
- B. Before installing countertops, examine shop-fabricated Work for completion and complete Work as required, including removal of packing.

3.2 INSTALLATION

- A. Grade: Install countertops to comply with same grade as item to be installed.
- B. Assemble countertops and complete fabrication at Project site to extent that it was not completed in shop.
 - 1. Provide cutouts for appliances, plumbing fixtures, electrical Work, and similar items. Locate openings accurately, and use templates or roughing-in diagrams to produce accurately sized and shaped openings. Sand edges of cutouts to remove splinters and burrs.
 - 2. Seal edges of cutouts by saturating with varnish.
- C. Field Jointing: Where possible, make in the same manner as shop jointing, using dowels, splines, adhesives, and fasteners recommended by manufacturer. Prepare edges to be joined in shop so Project-site processing of top and edge surfaces is not required. Locate field joints where shown on Shop Drawings.
 - 1. Secure field joints in countertops with concealed clamping devices located within 6 inches of front and back edges and at intervals not exceeding 24 inches. Tighten according to manufacturer's written instructions to exert a constant, heavy-clamping pressure at joints.
- D. Scribe and cut countertops to fit adjoining Work, refinish cut surfaces, and repair damaged finish at cuts.
- E. Countertop Installation: Anchor securely by screwing through corner blocks of base cabinets or other supports into underside of countertop.
 - 1. Install countertops level and true in line. Use concealed shims as required to maintain not more than a 1/8 inch in 96 inches variation from a straight, level plane.
 - 2. Secure backsplashes to tops with concealed metal brackets at 16 inches on center and to walls with adhesive.
 - 3. Seal joints between countertop and backsplash, if any, and joints where countertop and backsplash abut walls with mildew-resistant silicone sealant or another permanently elastic sealing compound recommended by countertop material manufacturer.

3.3 ADJUSTING

- A. Repair damaged and defective countertops, where possible, to eliminate functional and visual defects. Where not possible to repair, replace countertops. Adjust joinery for uniform appearance.

3.4 CLEANING

- A. Clean countertops on exposed and semiexposed surfaces.
- B. Protection: Provide Kraft paper or other suitable covering over countertop surfaces, taped to underside of countertop at a minimum of 48 inches on center. Remove protection at Substantial Completion.

END OF SECTION 123623.13

SECTION 123661.19
QUARTZ AGGLOMERATE COUNTERTOPS

PART 1 - GENERAL

1.1 SUMMARY

- A. Section Includes:
 - 1. Quartz agglomerate countertops.
 - 2. Quartz agglomerate backsplashes.
 - 3. Quartz agglomerate end splashes.

1.2 ADMINISTRATIVE REQUIREMENTS

- A. Coordination:
 - 1. Coordinate locations of utilities that will penetrate countertops or backsplashes.

1.3 ACTION SUBMITTALS

- A. Product Data: For countertop materials.
- B. Sustainable Design Submittals:
 - 1. Chain-of-Custody Certificates: For certified wood products. Include statement of costs.
 - 2. Product Data: For adhesives, indicating VOC content.
 - 3. Laboratory Test Reports: For adhesives, indicating compliance with requirements for low-emitting materials.
 - 4. Laboratory Test Reports: For composite wood products, indicating compliance with requirements for low-emitting materials.
- C. Shop Drawings: For countertops. Show materials, finishes, edge and backsplash profiles, methods of joining, cutouts for plumbing fixtures, and the following.
 - 1. Locations and details of joints.
 - 2. Direction of directional pattern, if any.
- D. Samples for Verification: For the following products:
 - 1. Countertop material, 6 inches square.

1.4 INFORMATIONAL SUBMITTALS

- A. Qualification Data: For fabricator.

1.5 CLOSEOUT SUBMITTALS

- A. Maintenance Data: For quartz agglomerate countertops to include in maintenance manuals. Include Product Data for care products used or recommended by Installer and names, addresses, and telephone numbers of local sources for products.

1.6 QUALITY ASSURANCE

- A. Fabricator Qualifications: Shop that employs skilled workers who custom-fabricate countertops similar to that required for this Project, and whose products have a record of successful in-service performance.
- B. Installer Qualifications: Fabricator of countertops.

- C. Mockups: Build mockups to demonstrate aesthetic effects and to set quality standards for fabrication and execution.
 - 1. Build mockup of typical countertop as shown on Drawings.
 - 2. Subject to compliance with requirements, approved mockups may become part of completed Work if undisturbed at time of Substantial Completion.

1.7 FIELD CONDITIONS

- A. Field Measurements: Verify dimensions of countertops by field measurements after base cabinets are installed but before countertop fabrication is complete.

PART 2 - PRODUCTS

2.1 QUARTZ AGGLOMERATE COUNTERTOP MATERIALS

- A. Quartz Agglomerate: Solid sheets consisting of quartz aggregates bound together with a matrix of filled plastic resin and complying with ICPA SS-1, except for composition.
 - 1. Products: Subject to compliance with requirements, provide products by the following manufacturer:
 - a. CaesarStone U.S.A., Inc.: CaesarStone Quartz Surfacing.
 - b. Cambria: Natural Quartz Surfaces.
 - c. Cosentino USA, Inc.: Dekton by Cosentino.
 - d. Daltile Corporation: One Quartz Surfaces; Micro Fleck Series.
 - e. DuPont Company: Zodiaq.
 - f. LG Hausys America Inc.: Viatera Quartz Surfaces.
 - g. Wilsonart Contract.: Wilsonart Quartz.
 - h. Approved substitution.
 - 2. Colors and Patterns: As indicated on Interior Finish Legend on Drawings.
- B. Composite Wood Products: Products shall be made using ultra-low-emitting formaldehyde resins as defined in California Air Resources Board's "Airborne Toxic Control Measure to Reduce Formaldehyde Emissions from Composite Wood Products" or shall be made with no added formaldehyde.
- C. Plywood: Exterior softwood plywood complying with DOC PS 1, Grade C-C Plugged, touch sanded.

2.2 COUNTERTOP FABRICATION

- A. Fabricate countertops according to quartz agglomerate manufacturer's written instructions and to AWI's "Architectural Woodwork Standards."
 - 1. Grade: Custom.
- B. Configuration: Fronts, backsplashes, and end splashes as detailed on Drawings.
- C. Countertops: 3 cm thick, quartz agglomerate with front edge built up with same material.
- D. Backsplashes: 2 cm thick, quartz agglomerate.
- E. Fabricate tops with shop-applied edges and backsplashes, unless otherwise indicated. Comply with quartz agglomerate manufacturer's written instructions for adhesives, sealers, fabrication, and finishing.
 - 1. Fabricate with loose backsplashes for field assembly.
- F. Joints: Fabricate countertops without joints.

- G. Cutouts and Holes:
1. Undercounter Plumbing Fixtures: Make cutouts for fixtures in shop using template or pattern furnished by fixture manufacturer. Form cutouts to smooth, even curves.
 - a. Provide vertical edges, slightly eased at juncture of cutout edges with top and bottom surfaces of countertop and projecting 3/16 inch into fixture opening.
 2. Counter-Mounted Plumbing Fixtures: Prepare countertops in shop for field cutting openings for counter-mounted fixtures. Mark tops for cutouts and drill holes at corners of cutout locations. Make corner holes of largest radius practical.
 3. Fittings: Drill countertops in shop for plumbing fittings, undercounter soap dispensers, and similar items.
 4. Counter-Mounted Cooktops: Prepare countertops in shop for field cutting openings for cooktops. Mark tops for cutouts and drill holes at corners of cutout locations. Make corner holes of largest radius practical.

2.3 INSTALLATION MATERIALS

- A. Adhesive: Product recommended by quartz agglomerate manufacturer.
1. Verify adhesives have a VOC content of 70 g/L or less.
 2. Verify adhesive complies with testing and product requirements of California Department of Public Health's "Standard Method for the Testing and Evaluation of Volatile Organic Chemical Emissions from Indoor Sources Using Environmental Chambers."
- B. Sealant for Countertops: Comply with applicable requirements in Section 079200 – Joint Sealants.

PART 3 - EXECUTION

3.1 EXAMINATION

- A. Examine substrates to receive quartz agglomerate countertops and conditions under which countertops will be installed, with Installer present, for compliance with requirements for installation tolerances and other conditions affecting performance of countertops.
- B. Proceed with installation only after unsatisfactory conditions have been corrected.

3.2 INSTALLATION

- A. Install countertops level to a tolerance of 1/8 inch in 8 feet, 1/4 inch maximum. Do not exceed 1/64 inch difference between planes of adjacent units.
- B. Fasten countertops by screwing through corner blocks of base units into underside of countertop. Predrill holes for screws as recommended by manufacturer. Align adjacent surfaces and, using adhesive in color to match countertop, form seams to comply with quartz agglomerate manufacturer's written instructions. Carefully dress joints smooth, remove surface scratches, and clean entire surface.
- C. Install backsplashes and end splashes by adhering to wall and countertops with adhesive. Mask areas of countertops and splashes adjacent to joints to prevent adhesive smears.
- D. Complete Cutouts not Finished in Shop. Mask areas of countertops adjacent to cutouts to prevent damage while cutting. Make cutouts to accurately fit items to be installed, and at right angles to finished surfaces unless beveling is required for clearance. Ease edges slightly to prevent snipping.
 1. Seal edges of cutouts in particleboard subtops by saturating with varnish.
- E. Apply sealant to gaps at walls; comply with Section 079200 – Joint Sealants.

END OF SECTION 123661.19

SECTION 134816
MANUFACTURED SOUND CONTROL COMPONENTS

PART 1 - GENERAL

1.1 SUMMARY

- A. Section Includes:
 - 1. Sound control mats for cementitious underlayments.
 - 2. Sound control underlayments for hard surface flooring.
 - 3. Resilient sound isolation systems for walls and ceilings.
 - 4. Sound damping and vibration isolation for trash chutes.
- B. Related Requirements:
 - 1. Section 035413 – Gypsum Cement Underlayment.
 - 2. Division 09 Sections for finish floor products specified to be installed over sound control underlayments.

1.2 ADMINISTRATIVE REQUIREMENTS

- A. Coordination: Coordinate installation of manufactured sound control components with the following:
 - 1. Sound control mats with application of cement underlayment.
 - 2. Sound control underlayments with requirements of floor covering products and adhesives, specified in Division 09 Sections, to ensure compatibility of products.
 - 3. Resilient sound isolation systems with gypsum board partition and ceiling assemblies.
 - 4. Thrash chutes with application of sound damping and installation of vibration isolator mounts.
- B. Preinstallation Meeting: Conduct meeting at Project site.

1.3 ACTION SUBMITTALS

- A. Product Data: For each type of product.
- B. Sustainable Design Submittals:
 - 1. Chain-of-Custody Certificates: For certified wood products. Include statement of costs.
 - 2. Chain-of-Custody Qualification Data: For manufacturer and vendor.
 - 3. Product Data: For coatings, indicating VOC content.
 - 4. Laboratory Test Reports: For coatings, indicating compliance with requirements for low-emitting materials.

1.4 INFORMATIONAL SUBMITTALS

- A. Qualification Data: For Installer.
- B. Test Reports: From qualified testing agency for the following:
 - 1. STC-rated assemblies.
 - 2. IIC-rated assemblies.
- C. Certified Wood: Provide an invoice including vendor's chain-of-custody number, product cost, and entity being invoiced.

1.5 QUALITY ASSURANCE

- A. Installer Qualifications: Installer who is approved by manufacturer for application of sound control mat and underlayment products required for this Project.
- B. Manufacturer Qualifications: A qualified manufacturer that is certified for chain of custody by an FSC-accredited certification body.
- C. Vendor Qualifications: A vendor that is certified for chain of custody by an FSC-accredited certification body.

1.6 FIELD CONDITIONS

- A. Environmental Limitations: Comply with manufacturer's written instructions for substrate temperature, ventilation, ambient temperature and humidity, and other conditions affecting underlayment performance.
 - 1. Place gypsum cement underlayments only when ambient temperature and temperature of substrates are between 50 and 80 deg F.

PART 2 - PRODUCTS

2.1 PERFORMANCE CRITERIA

- A. STC-Rated Assemblies: For STC-rated assemblies, provide materials and construction identical to those tested in assembly indicated on Drawings, according to ASTM E90 and classified according to ASTM E413 by an independent testing agency.
 - 1. STC Rating: Field-tested minimum of 50 unless indicated otherwise on Drawings.
- B. IIC-Rated Assemblies: For IIC-rated assemblies, provide materials and construction identical to those tested in assembly indicated, according to ASTM E492 and classified according to ASTM E989 by an independent testing agency.
 - 1. IIC Rating: Field-tested minimum of 50 unless indicated otherwise on Drawings.
- C. Sound Control Mats and Underlayments: Provide products that are GREENGUARD Certified for Indoor Air Quality.

2.2 WOOD PRODUCTS

- A. Certified Wood: The following wood products shall be certified as "FSC Pure" according to FSC STD-01-001 and FSC STD-40-004:
 - 1. SCU-3 Acoustical board underlayment.

2.3 SOUND CONTROL MATS

- A. Sound Control Mats (SCM): Composite roll form mats, designed to absorb sound when placed under cement underlayment installations, fabricated with a core of fused, entangled polymer filaments with nonwoven moisture-resistant fabric laminated on one side and, where scheduled, a highly compressible, nonwoven, acoustical fabric laminated to the other side.
- B. Sound Control Mat (SCM-1): Without acoustical fabric facing.
 - 1. Products: Subject to compliance with requirements, provide one of the following:
 - a. Keene Building Products: Quiet Qurl 025.
 - b. Maxxon Corporation: Acousti-Mat 1/4.
 - c. USG Corporation: Levelrock Brand SAM-N25 Sound Attenuation Mat.
 - d. Approved substitution.
 - 2. Thickness: Nominal 0.25 inch.
 - 3. Applications: Living rooms, kitchens, hallways, bathrooms, and where indicated.

- C. Sound Control Mat (SCM-2): With acoustical fabric facing.
 - 1. Products: Subject to compliance with requirements, provide one of the following:
 - a. Keene Building Products: Quiet Qurl 025 MT.
 - b. Maxxon Corporation: Acousti-Mat 1/4 Premium.
 - c. USG Corporation: Levelrock Brand SAM-N12 Ultra Sound Attenuation Mat.
 - d. Approved substitution.
 - 2. Thickness: Nominal 0.25 inch.
 - 3. Applications: Bedrooms, sleeping areas, common areas, amenity spaces, and where indicated.

2.4 SOUND CONTROL UNDERLAYMENTS

- A. Sound Control Underlayment (SCU): Sound reducing underlayment rolls consisting of impact-absorbing materials for installation underneath hard surface and resilient surface flooring.
- B. SCU-1: Recycled, non-rubber, acoustical underlayment roll mats.
 - 1. Products: Subject to compliance with requirements, provide one of the following:
 - a. Foam Products Corporation: Silencer LVT.
 - b. Regupol America, LLC: Sonus LV200.
 - c. Approved substitution.
 - 2. Material: 100 percent recycled foam or foam chips and cork granules.
 - 3. Thickness: Minimum 2 mm.
 - 4. Impact Insulation Class (IIC): Minimum of 50 [55].
 - 5. Application: Areas scheduled to receive vinyl plank flooring.
- C. SCU-2: Recycled rubber, acoustical underlayment roll mats.
 - 1. Products: Subject to compliance with requirements, provide one of the following:
 - a. Acoustic Solutions: Iso-Step Rubber Impact Sound Insulation.
 - b. Keene Building Products: QQ Step Soft.
 - c. Pliteq Inc.: GenieMat RST.
 - d. Regupol America, LLC: Sonus HS Series.
 - e. Studco Building Systems US, LLC: Resilmat, RM6 Series.
 - f. Approved substitution.
 - 2. Material: Not less than 85 percent recycled rubber.
 - 3. Thickness:
 - a. SCU-2A: 5 mm.
 - b. SCU-2B: 12 mm.
 - 4. Impact Insulation Class (IIC):
 - a. SCU-2A: Minimum IIC of 50 [55].
 - b. SCU-2B: Minimum IIC of 50 [55].
 - 5. Applications:
 - a. SCU-2A: Residential bathrooms scheduled to receive tile flooring.
 - b. SCU-2B: Public and common areas scheduled to receive tile flooring.
 - c. Floating engineered wood and hardwood flooring, laminate flooring surfaces.

2.5 RESILIENT SOUND ISOLATION SYSTEMS FOR WALLS

- A. Resilient Furring Channels (RFC): Steel sheet members designed to reduce sound transmission.
 - 1. Asymmetrical Single Leg (RFC-1):
 - a. Products: Subject to compliance with requirements, provide one of the following:
 - 1) CEMCO: RC1 Single Leg Resilient Channel.
 - 2) ClarkDietrich Building Systems: RC-1 Pro Resilient Channel.
 - 3) SCAFCO Steel Stud Company: Serenity-RC-Plus.
 - 4) Steeler Inc.: Resilient Channel One Leg.
 - 5) Studco Building Systems US, LLC: Resilmat, RC1 Series.
 - 6) Approved substitution.

- b. Size: 1-1/4 inch top flange, 1/2 inch attachment flanges, and 2 inch overall width by 1/2 inch deep.
 - c. Thickness: 0.0179 inch.
 - 2. Hat-Shaped Double Leg (RFC-2):
 - a. Products: Subject to compliance with requirements, provide one of the following:
 - 1) CEMCO: RC2 Double-Legged Resilient Channels.
 - 2) ClarkDietrich Building Systems: RC-2 Pro Resilient Channel.
 - 3) SCAFCO Steel Stud Company: D20 Hat Furring.
 - 4) Steeler Inc.: Steeler Furring Channel.
 - 5) Studco Building Systems US, LLC: Resilmat, RC2 Series.
 - 6) Approved substitution.
 - b. Size: 1-1/4 inch top flange, two 1/2 inch attachment flanges, and 2-1/2 inch overall width by 1/2 inch deep.
 - c. Metal Thickness: 0.0179 inch.
- B. Resilient Sound Isolation Clips (RSIC-1): Metal and rubber clip system for reducing sound transmission in wall and ceiling assemblies when used in conjunction with appropriate metal furring channels.
 - 1. Products: Subject to compliance with requirements, provide one of the following:
 - a. ClarkDietrich Building Systems: CDSC Sound Clip.
 - b. PAC International, Inc.: RSIC-1.
 - c. Pliteq Inc.: GenieClip RST.
 - d. Regupol America, LLC: SonusClip.
 - e. Soundproofing Company (The): RSIC-1 Resilient Sound Isolation Clip.
 - f. Studco Building Systems US, LLC: Resilmount A237R Sound Isolation Clip.
 - g. Approved substitution.
 - 2. Metal Clip: Galvanized or aluminum-zinc coated steel, minimum 0.0451 inch thick.
 - 3. Rubber Isolator: Natural or thermoplastic rubber compound, blended with fire-inhibiting compounds, molded to isolate ferrule from clip.
 - a. Minimum of 12 micro-vibration controlling pedestals at point of contact with framing member.
 - b. Manufactured to ASTM D2000, M2 AA 510 A13, which includes:
 - 1) Hardness: ASTM D2240, Shore A: 47.
 - 2) Modulus 300 Percent, ASTM D412, Die C: minimum 769 psi.
 - 3) Tensile Strength: ASTM D412, Die C; minimum 1,624 psi.
 - 4) Elongation at Break, ASTM D573: minimum 454 percent.
 - 4. Design Load Rating: Minimum 36 lbs./isolator when used with 0.0179 inch thick metal studs.
 - 5. Size: Nominal 3 inch by 1-1/4 inch by 1-7/16 inch.
 - 6. Ferrule: Zinc-electroplated steel.
 - 7. Projection: 1-5/8 inches from supporting structure with 7/8 inch drywall furring channels.
- C. Resilient Sound Isolation DeCoupling Brackets (RSIDB): Metal and rubber bracket system designed to reduce sound transmission in wall and ceiling assemblies.
 - 1. Products: Subject to compliance with requirements, provide one of the following:
 - a. PAC International, Inc.: RSIC-DC-0.
 - b. Pliteq Inc.: GenieClip LB.
 - c. Regupol America, LLC: SonusClip DE90.
 - d. Soundproofing Company (The): IB-3 Decoupling Bracket.
 - e. Studco Building Systems US, LLC: Resilmount A48R Sound Isolation Clip Bracket.
 - f. Approved substitution.
 - 2. Metal Bracket: Galvanized or aluminum-zinc coated steel, minimum 0.0451 inch thick
 - 3. Rubber Isolator: Natural or thermoplastic rubber compound, blended with fire-inhibiting compounds, molded to isolate ferrule from clip.
 - a. Minimum of 12 micro-vibration controlling pedestals at point of contact with framing member.

- b. Manufactured to ASTM D2000, M2 AA 510 A13, which includes:
 - 1) Hardness: ASTM D2240, Shore A: 47.
 - 2) Modulus 300 Percent, ASTM D412, Die C: 5.3 MPa.
 - 3) Tensile Strength, ASTM D412, Die C: 11.2 MPa.
 - 4) Elongation at Break, ASTM D573: 454 percent.
4. Load Capacity: Minimum design load of 36 pounds when used with 0.0179 inch thick metal studs.
5. Size: Minimum 1-5/8 inch wide, 1-3/4 inch deep, 4-3/8 inch high.
6. Clip: 0.0635 inch thick, galvanized or aluminum-zinc coated steel.
7. Ferrule: Zinc-electroplated steel.
8. Projection: 1-5/8 inches from supporting structure, when 7/8 inch drywall furring channels are used.

2.6 RESILIENT SOUND ISOLATION SYSTEMS FOR CEILINGS

- A. Gypsum Board Ceiling Hangers, General (GPCH): Resilient isolation hanger systems designed to reduce sound transmission in suspended gypsum board ceilings.
 1. Design Criteria:
 - a. Assembly shall provide a minimum of 30 degrees of vertical alignment of suspension member without making metal-to-metal contact between suspension and hanger assembly members.
 - b. Minimum Static Spring Deflection: 1 inch.
 - c. Maximum Natural Frequency: 4.4 Hz.
- B. Threaded Rod Ceiling Hangers, Concrete Deck (GPCH-1): Combination high-deflection steel spring in series with a resilient, molded neoprene noise and vibration isolation pad incorporated into a stamped steel hanger assembly that resiliently supports isolated ceilings. Assembly includes a leveling rod with an attached channel carrier.
 1. Products: Subject to compliance with requirements, provide one of the following:
 - a. Kinetics Noise Control, Inc.: Model ICC.
 - b. Mason Industries, Inc.: Type 30CC Series.
 - c. VMC Group: Model HS-1D Series.
 - d. Approved substitutions.
 2. Mounting: Mounted to underside of concrete deck directly with anchors or with threaded rods.
 3. Channel Carrier: Designed to accept singled 1/2 by 1-1/2 inch, 0.0538 inch thick cold-rolled steel ceiling framing channel.
- C. Wire-Tie Ceiling Hangers, Concrete Deck (GBCH-2): Combination high-deflection steel spring in series with a resilient, molded neoprene noise and vibration isolation pads at top and bottom of hanger bracket incorporated into a stamped steel hanger assembly that resiliently supports isolated ceilings. Hanger bracket incorporates welded eyebolts at top and bottom. Wire is used to suspend drywall ceiling grid.
 1. Products: Subject to compliance with requirements, provide one of the following:
 - a. Kinetics Noise Control, Inc.: Muta Hanger.
 - b. Mason Industries, Inc.: Type W30N Series.
 - c. VMC Group: Model RSHSC-1B Series.
 - d. Approved substitutions.
 2. Mounting: Mounted to underside of deck with wire attached to top eye bolt.
- D. Side-Mounted Ceiling Hangers, Wood Framing (GBCH-3): Combination high-deflection steel spring in series with a resilient, molded neoprene noise and vibration isolation pad incorporated into a stamped steel hanger assembly that resiliently supports isolated ceilings. Assembly includes a leveling rod with an attached channel carrier.
 1. Products: Subject to compliance with requirements, provide one of the following:
 - a. Kinetics Noise Control, Inc.: Model ICW.
 - b. Mason Industries, Inc.: Type 30SMCC Series.

- c. Approved substitutions.
- 2. Mounting: Mounted to underside of deck directly with anchors or with threaded rods.
- 3. Channel Carrier: Designed to accept single 0.0538 inch thick cold-rolled steel ceiling framing channel, 1-1/2 inch deep with 1/2 inch flanges.

2.7 SOUND DAMPING AND VIBRATION ISOLATION

- A. Vibration Isolator Mounts: Neoprene-covered steel, double deflection type mounts, with friction pads both top and bottom, and tapped hole with cap screw and washer on top.
 - 1. Products: Subject to compliance with requirements, provide one of the following:
 - a. Mason Industries: ND-A-Red Mount.
 - b. Korfund: RD Double Deflection Isolators.
 - c. Approved substitutions.
 - 2. Minimum Static Deflection: 0.35 inch.
 - 3. Weight Loading: Size mounts to accommodate weight of equipment.
- B. Sound Damping Coatings:
 - 1. Products: Subject to compliance with requirements, provide the following:
 - a. Type 1 Coating: Daubert Chemical Company, Inc.: V-Damp 3680 or Coating 932.
 - b. Type 2 Coating: Sound Seal: VBD-10 Damping Compound.
 - c. Approved substitutions.

2.8 ACCESSORIES

- A. Adhesive: Provided or recommended by sound control underlayment manufacture for adhering mats to substrate.
- B. Perimeter Isolation Strips: Sound control mat and underlayment manufacturers' foam isolation strips used to limit flanking sound and to prevent leakage of cement underlayment at perimeter of areas receiving sound control mats and at floor protrusions through sound control mats.
- C. Perimeter Isolation Tape: Sound control mat and underlayment manufacturers' tape used to adhere foam isolation strips to vertical surfaces.
- D. Tie Wire: ASTM A641, Class 1 zinc coating, soft temper, 0.1055 inch diameter wire, or double strand of 0.048 inch diameter wire.
- E. Fasteners and Anchors: As suitable for structure type and as approved by resilient component manufacturers.

PART 3 - EXECUTION

3.1 EXAMINATION

- A. Examine substrates, with Installer present, for conditions affecting performance of Work.
- B. Proceed with applications only after unsatisfactory conditions have been corrected.

3.2 PREPARATION

- A. A minimum of 24 hours prior to installation, unroll sound control underlayments and allow to relax before installing.
- B. Sound Control Mats: Ensure substrates scheduled to receive cement underlayment are ready for installation of sound control mats.
- C. Sound Control Underlayments: Ensure wood subfloors and underlayments scheduled to receive hard surface and resilient surface flooring are ready to receive installation of sound control underlayments.

- D. Suspended Assemblies: Coordinate installation of resilient sound isolation suspension systems with installation of overhead structure to ensure that inserts and other provisions for anchorages to building structure have been installed to receive hangers at spacing required to support Work and that hangers will develop their full strength.
 - 1. Furnish concrete inserts and other devices indicated to other trades for installation in advance of time needed for coordination and construction.

3.3 INSTALLATION OF SOUND CONTROL MATS

- A. Sound Control Mats: Install sound control mats according to manufacturer's written instructions.
 - 1. Include installation of perimeter isolation strips at perimeter of areas receiving sound control mats, including doorframes, and around protrusions through mats. Adhere foam perimeter isolation strip to wall with perimeter isolation tape
 - 2. Do not install mechanical fasteners that penetrate through sound control materials.
 - 3. Ensure sound control mat installation is ready to receive cement underlayment.

3.4 INSTALLATION OF SOUND CONTROL UNDERLAYMENTS

- A. A minimum of 48 hours prior to installation, place underlayment products in areas where scheduled for installation to allow products to relax before installing. Remove underlayment from packaging unless to relax unless manufacturer indicates otherwise.
- B. SCU-1:
 - 1. Adhere underlayment to subfloor using appropriate square notched trowel. Obtain full adhesive coverage over substrate.
 - 2. Lay underlayment into adhesive and follow manufacturer's instructions for application.
 - 3. Install underlayment with edges butted tightly together.
 - 4. Leave minimum of 3 mm gap around entire perimeter for expansion and contraction.
- C. SCU-2:
 - 1. Adhere underlayment to subfloor using appropriate square notched trowel. Obtain full adhesive coverage over substrate.
 - 2. Lay underlayment into adhesive and follow manufacturer's instructions for application.
 - 3. Install underlayment with edges butted tightly together.
 - 4. Leave minimum of 4 mm gap around entire perimeter for expansion and contraction and install perimeter isolation strips and adhere in place.
- D. SCU-3:
 - 1. Loose-lay underlayment over substrate with perimeter edges flush to walls and vertical surfaces..
 - 2. Install underlayment with edges butted tightly together.

3.5 INSTALLATION OF RESILIENT SOUND ISOLATION SYSTEMS

- A. Install resilient sound isolation components according to manufacturers' written instructions and ready to receive Work of the following:
 - 1. Section 092216 for installation of ceiling suspension and grid suspension systems for gypsum board ceilings.
 - 2. Section 092900 – Gypsum Board for installation of gypsum board.
- B. Install resilient components plumb, square, and true to line, with connections securely fastened.
 - 1. Space resilient sound isolation hangers at maximum of 48 by 48 inches on center for single layer of gypsum board, and 24 by 48 inches for double layers of gypsum board.
- C. Install resilient components according to spacings required to achieve specified STC and IIC ratings.

- D. Mechanically fasten resilient sound isolation components to structure using appropriate fasteners and anchors.
 - 1. Do not exceed design load (pull and shear) of 36 lbs. per isolation bracket.
- E. Install building components supported by ceiling hangers free from rigid contact with parts of non-isolated building structure to prevent inadvertent sound flanking.

3.6 INSTALLATION OF SOUND DAMPING AND VIBRATION ISOLATION

- A. Vibration Isolator Mounts: Neoprene-covered steel, double deflection type mounts, with friction pads both top and bottom, and tapped hole with cap screw and washer on top.
- B. Sound Damping Coatings:
 - 1. Type 1 Coating: Factory-applied to entire length of chute except where indicated otherwise.
 - 2. Type 2 Coating: Field-apply to minimum 3/16 inch thick on chute sections exposed in compactor rooms.

END OF SECTION 134816

SECTION 142400
HYDRAULIC ELEVATORS

PART 1 - GENERAL

1.1 SUMMARY

- A. Section Includes:
1. Hydraulic passenger elevators.

1.2 DEFINITIONS

- A. Definitions in ASME A17.1/CSA B44 apply to Work of this Section.
- B. Service Elevator: Passenger elevator that is also used to carry freight.

1.3 ADMINISTRATIVE REQUIREMENTS

- A. Coordination:
1. Coordinate installation of sleeves, block outs, elevator equipment with integral anchors, and other items that are embedded in concrete or masonry for elevator equipment. Furnish templates, sleeves, elevator equipment with integral anchors, and installation instructions and deliver to Project site in time for installation.
 2. Coordinate locations and dimensions of other Work relating to hydraulic elevators including pit ladders; sumps and floor drains in pits; entrance subsills; electrical service; and electrical outlets, lights, and switches in hoistways, machine rooms, and pits.
 3. Furnish well casing and coordinate delivery with related excavation Work.
- B. Preinstallation Meeting: Conduct meeting at Project site.
1. Meet with Owner, Architect, testing and inspecting agency representative, elevator Installer, elevator manufacturer's representative, and installers whose Work interfaces with or affects elevators, including installers of elevator accessories and elevator equipment.
 2. Review use of elevator for construction purposes, hours of use, scheduling of its use, cleanliness of cab, employment of operator, and maintenance of elevator systems.
 3. Review installation schedule, methods and procedures related to elevator installation, including manufacturer's written instructions, and coordination with Work that interfaces with or affects elevators.

1.4 ACTION SUBMITTALS

- A. Product Data: Include capacities, sizes, performances, operations, safety features, finishes, and similar information. Include product data for car enclosures; hoistway entrances; and operation, control, and signal systems.
- B. Shop Drawings:
1. Include plans, elevations, sections, and large-scale details indicating service at each landing; machine room layout; coordination with building structure; relationships with other construction; and locations of equipment.
 2. Include large-scale layout of car-control station and standby power operation control panel.
 3. Indicate maximum dynamic and static loads imposed on building structure at points of support as well as maximum and average power demands.
- C. Samples for Verification: For exposed car, hoistway door and frame, and signal equipment finishes, 3 inch square Samples of sheet materials and 4 inch lengths of running trim members.

1.5 INFORMATIONAL SUBMITTALS

- A. Qualification Data: For Installer.
- B. Seismic Qualification Certificates: For elevator equipment, accessories, and components, from manufacturer.
 - 1. Basis for Certification: Indicate whether withstand certification is based on actual test of assembled components or on calculation.
 - 2. Dimensioned Outline Drawings of Equipment Unit: Identify center of gravity and locate and describe mounting and anchorage provisions.
 - 3. Detailed description of equipment anchorage devices on which the certification is based and their installation requirements.
- C. Manufacturer Certificates: Signed by elevator manufacturer, certifying that hoistway, machine room, and pit layouts and dimensions, as shown on Drawings, and electrical service including standby-power generator, as shown and specified, are adequate for elevator system being provided.
- D. Sample Warranty: For special warranty.

1.6 CLOSEOUT SUBMITTALS

- A. Operation and Maintenance Data: For elevators to include in emergency, operation, and maintenance manuals.
 - 1. Submit manufacturer's or Installer's standard operation and maintenance manual in accordance with ASME A17.1/CSA B44.
- B. Inspection and Acceptance Certificates and Operating Permits: As required by authorities having jurisdiction for normal, unrestricted elevator use.
- C. Continuing Maintenance Proposal:
 - 1. Submit a continuing maintenance proposal from Installer to Owner, in form of a standard 1 year maintenance agreement, starting on date initial maintenance service is concluded. State services, obligations, conditions, and terms for agreement period and for future renewal options.

1.7 QUALITY ASSURANCE

- A. Manufacturer's Qualifications: Elevator manufacturer or an authorized representative with not less than 10 years of successful installations of specified products, and capable of providing field service representation during construction and approving application method.
- B. Installer Qualifications: Qualified Installer who is trained and approved by elevator manufacturer, with not less than 5 years of successful installations of specified products.
 - 1. Successfully completed not less than 5 comparable scale projects installing specified products.

1.8 DELIVERY, STORAGE, AND HANDLING

- A. Deliver, store, and handle materials, components and equipment in manufacturer's protective packaging. Store materials, components, and equipment off of ground, under cover, in a dry location.

1.9 WARRANTY

- A. Manufacturer's Special Warranty: Manufacturer agrees to repair, restore, or replace elevator Work that fails in materials or workmanship within specified warranty period.
 - 1. Failures include operation or control system failure, including excessive malfunctions; performances below specified ratings; excessive wear; unusual deterioration or aging of materials or finishes; unsafe conditions; need for excessive maintenance; abnormal noise or vibration; and similar unusual, unexpected, and unsatisfactory conditions.
 - 2. Warranty Period: 1 year from date of Substantial Completion.

PART 2 - PRODUCTS

2.1 MANUFACTURERS

- A. Basis-of-Design Product: Design for elevator is based on endura Below-Ground by ThyssenKrupp Elevator. Subject to compliance with requirements, provide named product or approved substitution from one of the following:
 - 1. Otis Elevator Company.
 - 2. Schindler Elevator Corp.
 - 3. Approved substitution.
- B. Source Limitations: Obtain elevators from single manufacturer.
 - 1. Major elevator components, including pump-and-tank units, plunger-cylinder assemblies, controllers, signal fixtures, door operators, car frames, cars, and entrances, shall be manufactured by single manufacturer.

2.2 PERFORMANCE CRITERIA

- A. Regulatory Requirements: Comply with ASME A17.1/CSA B44.
- B. Accessibility Requirements: Comply with requirements for accessible elevators in United States Access Board's ADA-ABA Accessibility Guidelines and with ICC A117.1.
- C. Seismic Performance: Elevator system shall withstand effects of earthquake motions determined according to ASCE 7 and shall comply with elevator seismic requirements in ASME A17.1/CSA B44.
 - 1. The term "withstand" means "the system will remain in place without separation of any parts when subjected to seismic forces specified and system will be fully operational after seismic event."
 - 2. Project Seismic Design Category: D.
 - 3. Elevator Component Importance Factor: 1.5.
 - 4. Provide earthquake equipment required by ASME A17.1/CSA B44.
 - 5. Provide seismic detection device required by ASCE 7.
- D. Differential Door Time: Provide separate, adjustable timers set the following amount of time that doors remain open after stopping in response to calls.
 - 1. Car Call: Hold open time adjustable between 3.0 and 5.0 seconds.
 - 2. Hall Call: Hold open time adjustable between 5.0 and 8.0 seconds. hall call time will be engaged when car responds to coincidental calls.

2.3 ELEVATORS

- A. Elevator System, General: Manufacturer's standard elevator systems. Unless otherwise indicated, manufacturers' standard components shall be used, as included in standard elevator systems and as required for complete system.

- B. Elevator Description:
1. Type: Under-the-car single cylinder.
 2. Rated Load: 3,500 lb unless indicated otherwise.
 3. Rated Speed: 150 fpm.
 4. Operation System: TAC32.
 5. Auxiliary Operations:
 - a. Battery-powered lowering.
 - b. Automatic dispatching of loaded car.
 - c. Loaded-car bypass.
 - d. Off-peak operation.
 - e. Automatic operation of lights and ventilation fans.
 - f. Distributed parking.
 - g. Emergency hospital service at all floors.
 6. Security Features:
 - a. Key switch operation.
 7. Car Enclosures:
 - a. Inside Width: 80 inches from side wall to side wall.
 - b. Inside Depth: 65 inches from back wall to front wall (return panels).
 - c. Inside Height: 88 inches to underside of cab.
 - d. Front Walls (Return Panels): Satin stainless steel, No. 4 finish with integral car door frames.
 - e. Side and Rear Wall Panels: Satin stainless steel, No. 4 finish.
 - f. Door Faces (Interior): Satin stainless steel, No. 4 finish.
 - g. Door Sills: Aluminum, mill finish.
 - h. Ceiling: Satin stainless steel, No. 4 finish with recessed LED downlights.
 - i. Handrails: 1-1/2 inches round satin stainless steel, No. 4 finish, at sides and rear of car.
 - j. Floor prepared to receive resilient flooring as indicated on Interior Finish Legend on Drawings.
 8. Hoistway Entrances:
 - a. Width: 42 inches.
 - b. Height: 84 inches.
 - c. Type: Single-speed side sliding.
 - d. Power Characteristics: 460 volts, 3 Phase, 60 Hz.
 - e. Frames: Satin stainless steel, No. 4 finish.
 - f. Doors: Satin stainless steel, No. 4 finish.
 - g. Sills: Aluminum, mill finish.
 9. Hall Fixtures: Satin stainless steel, No. 4 finish.
 10. Additional Requirements:
 - a. Provide inspection certificate in each car, mounted under acrylic cover with frame made from satin stainless steel, No. 4 finish.
 - b. Provide hooks for protective pads in service car and 2 complete sets of full-height protective blankets.

2.4 SYSTEMS AND COMPONENTS

- A. Pump Units: Positive-displacement type with a maximum of 10 percent variation between no load and full load and with minimum pulsations.
1. Pump: Submersible type with submersible squirrel-cage induction motor, and shall be suspended inside oil tank from vibration isolation mounts or shall be tank-top-mounted type with fan-cooled, squirrel-cage induction motor, and shall be mounted on oil tank with vibration isolation mounts and enclosed in prime-painted steel enclosure lined with 1 inch thick, glass-fiber insulation board.
 2. Motor Starting: Solid-state starting.
 3. Motor Control: Variable-voltage, variable-frequency.

- B. Hydraulic Silencers: System shall have hydraulic silencer containing pulsation-absorbing material in blowout-proof housing at pump unit.
- C. Piping: Size, type, and weight of piping as recommended by elevator manufacturer, with flexible connectors to minimize sound and vibration transmissions from power unit.
 - 1. Casing for Underground Piping: Schedule 40 PVC pipe complying with ASTM D1785, joined with PVC fittings complying with ASTM D2466 and solvent cement complying with ASTM D2564.
- D. Hydraulic Fluid: Nontoxic, biodegradable, fire-resistant fluid, made from vegetable oil with antioxidant, anticorrosive, antifoaming, and metal-passivating additives, that is approved by elevator manufacturer for use with elevator equipment.
- E. Inserts: Furnish required concrete and masonry inserts and similar anchorage devices for installing guide rails, machinery, and other components of elevator Work. Device installation is specified in another Section.
- F. Protective Cylinder Casing: PVC or HDPE pipe casing complying with ASME A17.1/CSA B44, of sufficient size to provide not less than 1-inch clearance from cylinder and extending above pit floor. Casing shall have means of monitoring effectiveness to comply with ASME A17.1/CSA B44.
- G. Car Frame and Platform: Welded steel units.
- H. Guides: Polymer-coated, nonlubricated sliding guides; or sliding guides with guide-rail lubricators. Provide guides at top and bottom of car frames.
- I. Door Interlocks: Equip each hoistway with approved type interlock, tested as required by AHJ, designed to prevent operation of cars away from landing until doors are locked in closed position as defined by applicable code and to prevent opening of doors at any landing from corridor side unless car is at rest at that landing or is in level zone and stopping at that landing.

2.5 OPERATION SYSTEMS

- A. Provide manufacturer's standard microprocessor operation system as required to provide type of operation indicated.
- B. Drive: Variable Voltage Variable Frequency AC drive system to develop high starting torque with low starting current.
- C. Auxiliary Operations:
 - 1. General: Main lobby is considered Designated Floor unless indicated otherwise.
 - 2. Group Standby Power Operation:
 - a. On activation of building's standby power, cars are returned to Designated Floor and doors open for approximately 3 seconds, doors close, and parks car. 1 car is returned at a time, with priority given to loaded cars. If car cannot be returned after 2 attempts, it is removed from system. When cars have been returned or removed from system, 1 car is automatically placed in service. If car selected for service cannot operate within 30 seconds, system removes car from service and places another car in service.
 - b. Cars can be manually put in service on standby power, either for return operation or for regular operation, by switches in control panel located at Designated Floor. Manual operation causes automatic operation to cease.
 - 3. Automatic Dispatching of Loaded Car: When car load exceeds 80 percent of rated capacity, doors begin closing.
 - 4. Nuisance-Call Cancel: When car calls exceed a preset number while car load is less than a predetermined weight, all car calls are canceled. Preset number of calls and predetermined weight can be adjusted.
 - 5. Loaded-Car Bypass: When car load exceeds 80 percent of rated capacity, car responds only to car calls, not to hall calls.

6. Off-Peak Operation: During periods of low traffic, half of the elevators in a group shall be taken out of service and switched to low-power mode.
 7. Independent Service: Key switch in car-control station removes car from group operation and allows it to respond only to car calls. Key cannot be removed from key switch when car is in independent service. When in independent service, doors close only in response to door close button.
 8. Automatic Operation of Lights and Fan: When elevator is stopped and unoccupied with doors closed, lighting, ventilation fan, and cab displays are de-energized after 5 minutes and are re-energized before car doors open.
- D. Security Features: Security features shall not affect emergency firefighters' service.
1. Key Switch Operation: Push buttons are activated and deactivated by security key switches at car-control stations. Key is removable only in deactivated position unless indicated otherwise.

2.6 DOOR REOPENING DEVICES

- A. Infrared Reopening Device: Black, fully-enclosed, microprocessor-controlled door-reopening device with minimum of 80 infrared light beams extending vertically along leading edge of each door panel to minimum height of 84 Inches above finished floor projecting across car entrance. Interruption of one or more light beams prevents doors from closing and reverses doors at normal opening speed, except during nudging operation. In event of device failure, provide for automatic shutdown of car at floor level with doors remaining open.
1. Doors shall not begin to close until light beam has been re-established for an adjustable time of 1.0 to 5.0 seconds, with initial delay set for 3.0 seconds.
 2. Mechanical reopening devices are not acceptable.
- B. Door Restrictors: Provide door restrictors with door operators. Door restrictors prevent elevator car doors from opening if elevators are not within code required distance of hoistway landing.
- C. Nudging Feature: After car doors are prevented from closing for predetermined adjustable time (minimum 20.0 to 25.0 seconds), through activating door reopening device, a warning buzzer shall sound and doors shall begin to close at reduced kinetic energy of maximum of 2.5 lbf. Activation of door open button overrides nudging operation and reopens doors.

2.7 CAR ENCLOSURES

- A. General: Provide steel-framed car enclosures with nonremovable wall panels, with car roof, access doors, power door operators, and ventilation.
1. Provide standard railings complying with ASME A17.1/CSA B44 on car tops where required by ASME A17.1/CSA B44.
- B. Materials and Finishes: Manufacturer's standards, but not less than the following, unless indicated otherwise on Drawings:
1. Subfloor: Exterior, underlayment grade plywood, not less than 5/8 inch nominal thickness.
 2. Floor Finish: As indicated in Interior Finish Legend on Drawings.
 3. Stainless-Steel Wall Panels: Flush, formed-metal construction; fabricated from stainless-steel sheet.
 4. Fabricate car with recesses and cutouts for signal equipment.
 5. Stainless-Steel Doors: Flush, hollow-metal construction; fabricated from stainless-steel sheet.
 6. Sight Guards: Provide sight guards on car doors.
 7. Sills: Extruded or machined metal, with grooved surface, 1/4 inch thick.
 8. Luminous Ceiling: Fluorescent light fixtures and ceiling panels of translucent acrylic or other permanent rigid plastic.
 9. Metal Ceiling: Flush panels, with 4 low-voltage downlights in each panel. Align ceiling panel joints with joints between wall panels.

10. Light Fixture Efficiency: Not less than 35 lumens/W.
11. Ventilation Fan Efficiency: Not less than 3.0 cfm/W.

2.8 HOISTWAY ENTRANCES

- A. Hoistway Entrance Assemblies: Manufacturer's standard horizontal-sliding, door-and-frame hoistway entrances complete with track systems, hardware, sills, and accessories. Frame size and profile shall accommodate hoistway wall construction.
 1. Where gypsum board wall construction is indicated, frames shall be self-supporting with reinforced head sections.
- B. Fire-Rated Hoistway Entrance Assemblies: Door-and-frame assemblies shall comply with NFPA 80 and be listed and labeled by a testing and inspecting agency acceptable to authorities having jurisdiction based on testing at as close-to-neutral pressure as possible according to NFPA 252 or UL 10B.
 1. Fire-Protection Rating: 1-1/2 hours.
- C. Materials and Fabrication: Manufacturer's standards, but not less than the following:
 1. Enameled or Powder-Coated Steel Frames: Formed from cold- or hot-rolled steel sheet. Provide with factory-applied enamel or powder-coat finish.
 - a. Color: As indicated in Interior Finish Schedule on Drawings.
 2. Stainless-Steel Frames: Formed from stainless-steel sheet.
 3. Star of Life Symbol: Identify emergency elevators with star of life symbol, minimum of 3 inches high, on both jambs of hoistway door frames.
 4. Stainless-Steel Doors: Flush, hollow-metal construction; fabricated from stainless-steel sheet or by laminating stainless-steel sheet to exposed faces and edges of enameled cold-rolled steel doors using adhesive that fully bonds metal to metal without telegraphing or oil-canning.
 5. Sight Guards: Provide sight guards on doors matching door edges.
 6. Sills: Extruded metal, with grooved surface, 1/4 inch thick.
 7. Nonshrink, Nonmetallic Grout: Factory-packaged, nonstaining, noncorrosive, nongaseous grout complying with ASTM C1107.

2.9 SIGNAL EQUIPMENT

- A. General: Provide hall-call and car-call buttons that light when activated and remain lit until call has been fulfilled. Provide vandal-resistant buttons and lighted elements illuminated with LEDs.
 1. LED Color: White.
- B. Car Control Stations: Manufacturer's standard, vandal-resistant, recessed car control station mounted in return panel adjacent to car door and with buttons, switches, controls, and indicator lights projecting through return panel but substantially flush with face of return panel.
 1. Mark buttons and switches with standard identification for required use or function that complies with ASME A17.1/CSA B44. Use both tactile symbols and Braille.
 2. Car Control Panel Features:
 - a. Car position indicator.
 - b. Elevator Data Plate marked with elevator capacity and car number on car top.
 - c. Help buttons with raised markings.
 - d. In car stop switch per local code.
 - e. Firefighter's hat.
 - f. Firefighter's Phase II Key-switch.
 - g. Call Cancel Button.
 - h. Pre-programmed integrated ADA phone.
 - i. Emergency communication system.
 3. Provide "No Smoking" sign matching car-control station, either integral with car-control station or mounted adjacent to it, with text and graphics as required by authorities having jurisdiction.

- C. Emergency Communication System: 2-way voice communication system, with visible signal, which dials preprogrammed number of monitoring station and does not require handset use. System is contained in flush-mounted cabinet, with identification and instructions for use.
- D. Firefighters' 2-Way Telephone Communication Service: Provide flush-mounted cabinet in each car and required conductors in traveling cable for firefighters' 2-way telephone communication service specified in Division 28 Section for Fire-Alarm Systems.
- E. Fire Alarm Communication: Design system to incorporate communication to building's fire alarm system according to applicable building code.
- F. Car Position Indicator: Illuminated, alpha-numeric, digital-type car position indicator consisting of floor designations and direction arrows to indicate floor served and direction of car travel.
 - 1. Location: Above integral front return panel car-control station.
 - 2. Quantity: Provide 2 fixtures for passenger elevators and 1 fixture for service elevators.
 - 3. Number and Arrow Size: Minimum of 1 inch high.
 - 4. Audible Signals: To indicate car arrival and direction of travel.
- G. Hall Annunciator: With each hall lantern, provide audible signals indicating car arrival and direction of travel.
- H. Audible Signal: Minimum 20 dB audio tone and maximum 1,500 Hz frequency to indicate to passengers that car is either stopping at or passing each floor served. Signals sound once for up and twice for down.
 - 1. Sound Level: Measured at 60 inches in front of hall push-button stations.
 - 2. Location: Mounted at 36 inches above finished floor.
 - 3. Voice Synthesizer: Electronic device with reprogrammable message and female voice to announce car direction, floor, emergency exiting instructions, and other information.
- I. Hall Push-Button Stations: Provide 1 hall push-button station at each landing for each single elevator or group of elevators, but not less than 1 station for each 4 elevators in a group.
 - 1. Provide manufacturer's standard wall-mounted units unless indicated otherwise.
 - 2. Equip units with buttons for calling elevator and for indicating applicable direction of travel.
- J. Hall Lanterns: Units with illuminated directional arrows; provide single arrow at terminal landings. Provide the following:
 - 1. Location: At right side of each hoistway door at height complying with ADA.
- K. Hall Position Indicators: Illuminated, digital display-type position indicators. Provide units with flat faceplate for mounting with body of unit recessed in wall.
 - 1. Integrate ground-floor hall lanterns with hall position indicators.
 - 2. Quantity: Provide 2 fixtures for passenger elevators and 1 fixture for service elevators.
 - 3. Number and Arrow Size: Minimum of 1 inch high.
 - 4. Audible Signals: To indicate car arrival and direction of travel.
 - 5. Locations: Above hoistway entrance at ground floor.
- L. Standby Power Elevator Selector Switches: Provide switches, as required by ASME A17.1/CSA B44, where indicated. Adjacent to switches, provide illuminated signal that indicates when normal power supply has failed.
- M. Emergency Pictorial Signs: Fabricate from materials matching hall push-button stations, with text and graphics as required by authorities having jurisdiction, indicating that in case of fire, elevators are out of service and exits should be used instead. Provide 1 sign at each hall push-button station unless otherwise indicated.

2.10 FIREFIGHTER'S CONTROL PANEL

- A. Firefighter's Emergency Operation: Provide fire control panel consisting of the following:
 - 1. Phase I Fire Service key switch with appropriate engraved operating instructions.
 - 2. Digital Position Indicator for each elevator indicating, door open status and other features required by AHJ.
 - 3. Emergency power switch for manually selecting elevators to run during emergency power operation.
 - 4. Intercom to communicate to each car, machine room, and elevator lobby at designated floor.
 - 5. Location: Where indicated on Drawings.
- B. Firefighter's Key Box: Provide key box in size and color as required by AHJ. Locate key box adjacent to control room access door or where indicated on Drawings.
 - 1. Contents: Elevator keys and control room access key as required by ASME A17.1/CSA B44.
 - 2. Phase I Key: FEO-K1-Group 3 unless indicated otherwise.

2.11 FINISH MATERIALS

- A. Cold-Rolled Steel Sheet: ASTM A1008, commercial steel, Type B, exposed, matte finish.
- B. Hot-Rolled Steel Sheet: ASTM A1011, commercial steel, Type B, pickled.
- C. Stainless-Steel Sheet: ASTM A240, Type 304.
- D. Stainless-Steel Bars: ASTM A276, Type 304.
- E. Stainless-Steel Tubing: ASTM A554, Grade MT 304.
- F. Aluminum Extrusions: ASTM B221, Alloy 6063.

PART 3 - EXECUTION

3.1 EXAMINATION

- A. Examine elevator areas, with Installer present, for compliance with requirements for installation tolerances and other conditions affecting performance of Work. Examine hoistways, hoistway openings, machine rooms, and pits as constructed. Verify critical dimensions; and examine supporting structure and other conditions under which elevator Work is to be installed.
- B. Prepare written report, endorsed by Installer, listing dimensional discrepancies and conditions detrimental to performance or indicating that dimensions and conditions were found to be satisfactory.
- C. Proceed with installation only after unsatisfactory conditions have been corrected.

3.2 INSTALLATION

- A. Comply with manufacturer's written instructions.
- B. Install cylinder plumb and accurately centered for elevator car position and travel. Anchor securely in place, supported at pit floor and braced at intervals as needed to maintain alignment. Anchor cylinder guides at spacing needed to maintain alignment and avoid overstressing guides.
- C. Welded Construction: Provide welded connections for installing elevator Work where bolted connections are not required for subsequent removal or for normal operation, adjustment, inspection, maintenance, and replacement of worn parts. Comply with AWS workmanship and welding operator qualification standards.

- D. Sound Isolation: Mount rotating and vibrating equipment on vibration-isolating mounts to minimize vibration transmission to structure and structure-borne noise due to elevator system.
- E. Install piping above floor, where possible. Install underground piping in casing.
 - 1. Excavate for piping and backfill encased piping according to applicable requirements in Division 31 Section for Earth Moving.
- F. Lubricate operating parts of systems as recommended by manufacturers.
- G. Alignment: Coordinate installation of hoistway entrances with installation of elevator guide rails for accurate alignment of entrances with car. Where possible, delay installation of sills and frames until car is operable in shaft. Reduce clearances to minimum, safe, workable dimension at each landing.
- H. Leveling Tolerance: 1/8 inch, up or down, regardless of load and travel direction.
- I. Set sills flush with finished floor surface at landing. Fill space under sill solidly with nonshrink, nonmetallic grout.
- J. Locate hall signal equipment for elevators as follows unless otherwise indicated:
 - 1. For groups of elevators, locate hall push-button stations between 2 elevators at center of group or at location most convenient for approaching passengers.
 - 2. Place hall lanterns either above or beside each hoistway entrance.
 - 3. Mount hall lanterns at a minimum of 72 inches above finished floor.

3.3 FIELD QUALITY CONTROL

- A. Acceptance Testing: On completion of elevator installation and before permitting use (either temporary or permanent) of elevators, perform acceptance tests as required and recommended by ASME A17.1/CSA B44 and by governing regulations and agencies.
- B. Advise Owner, Architect, and authorities having jurisdiction in advance of dates and times tests are to be performed on elevators.

3.4 ADJUSTING

- A. After construction operations and prior to Substantial Completion, adjust elevator for smooth acceleration and deceleration of cars.
- B. Leveling Tolerance: Adjust automatic leveling for maximum of 1/8 inch, up or down, regardless of load and direction of travel.

3.5 CLEANING

- A. Remove protective coverings from finished surfaces.
- B. Clean surfaces and components using appropriate cleaning products and according to manufacturer's written instructions.
- C. Remove construction debris from hoistways and properly dispose.

3.6 DEMONSTRATION

- A. Engage a factory-authorized service representative to train Owner's maintenance personnel to operate elevator(s).
 - 1. Provide minimum of 1 hour training on security features to Owner's designated staff.
- B. Check operation of each elevator with Owner's personnel present before date of Substantial Completion and again not more than 1 month before end of warranty period. Determine that operation systems and devices are functioning properly.

3.7 PROTECTION

- A. Temporary Use: Use of elevator during construction is not allowed unless specifically approved in writing by Architect or Owner. If temporary use is permitted, comply with the following:
1. Protect finishes from damage.
 2. Provide strippable protective film on entrance and car doors and frames.
 3. Provide padded wood bumpers on entrance door frames covering jambs and frame faces.
 4. Protect elevator and elevator equipment.
 5. Do not load elevators beyond their rated weight capacity.
 6. Provide preventive maintenance, repair or replacement of worn or defective components, lubrication, cleanup, and adjustment as necessary for proper elevator operation at rated speed and capacity. Provide parts and supplies same as those used in manufacture and installation of original equipment.
 7. Restore damaged Work so no evidence remains of correction. Return items to shop that cannot be refinished in field, make required repairs and refinish entire unit, or provide new units as required.
- B. Provide protection until Substantial Completion.

3.8 MAINTENANCE

- A. Initial Maintenance Service: Beginning at Substantial Completion, maintenance service shall include 12 months' full maintenance by skilled employees of elevator Installer. Include monthly preventive maintenance, repair or replacement of worn or defective components, lubrication, cleaning, and adjusting as required for proper elevator operation. Parts and supplies shall be manufacturer's authorized replacement parts and supplies.
1. Perform maintenance during normal working hours.
 2. Perform emergency callback service during normal working hours with response time of 2 hours or less.

END OF SECTION 142400

APPENDIX A
LIGHT FIXTURE PRODUCT DATA

1.1 ATTACHMENTS

- A. Product Data sheets for specified light fixtures.

END OF APPENDIX A



EHA BAKER HEIGHTS

CUTSHEET PACKAGE

06/08/2020

Project		Catalog #		Type	
Prepared by		Notes		Date	



Metalux

SNLED Lensed

Lensed LED Strip Round and Square Lens

Typical Applications

Storage / Utility • Coves • Display Cases • Task and General Area

Interactive Menu

- Order Information [page 2](#)
- Photometric Data [page 3](#)
- Product Warranty

Top Product Features

- Standard (SL) and High lumen/High Efficacy (HL) packages
- High efficiencies - up to 153 LPW
- Three different lens types for optical control
- Two different reflectors for precise distribution control
- Available CCT: 3000K, 3500K, 4000K and 5000K
- Minimum CRI of 80; 90 CRI available

Product Certification



Product Features



Dimensional Details

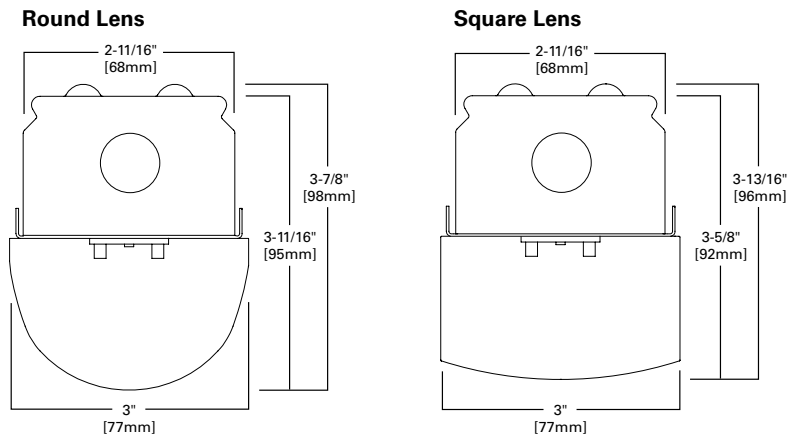

[additional product diagrams](#)

Order Information

SAMPLE ORDER NUMBER: **4SNLED-LD5-46SL-LN-UNV-L835-CD1-U**
8TNSLED-LD5-200HL-SLN-UNV-EL7W-L840-CD2-U

Length	Series	Lamp Type
2=2 ft. 4=4 ft. 8T=8 ft.	SNLED=Commercial LED Striplight (9)	LD5=LED 5.0
Notes		
(9) DesignLights Consortium® Qualified and classified for both DLC Standard and DLC Premium, refer to www.designlights.org for details.		

LED Lumen Packages

LED Lumen Packages (1)

2 ft. Round Lens			4 ft. Round Lens			8 ft. Round Lens			2 ft. Square Lens			4 ft. Square Lens			8 ft. Square Lens		
LC	LN	LW	LC	LN	LW	LC	LN	LW	SLC	SLN	SLW	SLC	SLN	SLW	SLC	SLN	SLW
18SL	18SL	16SL	18SL	18SL	16SL	60SL	60SL	54SL	19SL	19SL	16SL	19SL	19SL	15SL	60SL	64SL	50SL
22SL	22SL	20SL	22SL	22SL	20SL	68SL	68SL	61SL	24SL	24SL	20SL	23SL	23SL	19SL	70SL	70SL	58SL
26SL	26SL	23SL	26SL	26SL	23SL	75SL	75SL	67SL	27SL	27SL	22SL	27SL	27SL	22SL	78SL	77SL	64SL
34HL	32HL	30HL	30SL	30SL	27SL	83SL	83SL	74SL	37HL	37HL	30HL	30SL	30SL	25SL	84SL	84SL	70SL
Clear	Semi-frost narrow	Full frost wide	34SL	34SL	30SL	90SL	91SL	81SL	Clear	Semi-frost narrow	Full frost wide	35SL	35SL	29SL	93SL	93SL	77SL
			37SL	37SL	33SL	98SL	98SL	88SL				39SL	39SL	32SL	100SL	100SL	83SL
			41SL	41SL	37SL	105SL (10)	106SL	95SL	42SL	42SL	35SL	42SL	42SL	35SL	108SL	108SL	90SL
			46SL	46SL	41SL	130HL (10)	130HL (10)	110HL	47SL	46SL	39SL	47SL	46SL	39SL	116SL	116SL	96SL
			49SL	53SL	44SL	170HL (10)	170HL (10)	150HL	50SL	50SL	41SL	50SL	50SL	41SL	125SL	125SL	104SL
			52SL	56SL	47SL	Clear	Semi-frost narrow	Full frost wide	54SL	54SL	45SL	54SL	54SL	45SL	131SL	130SL	108SL
			56SL	61SL	50SL				58SL	58SL	48SL	58SL	58SL	48SL	58SL	58SL	48SL
			63SL	64SL	56SL				63SL	63SL	52SL	63SL	63SL	52SL	170HL (10)	170HL (10)	170HL (10)
			66SL	50HL	58SL				65SL	65SL	54SL	65SL	65SL	54SL	200HL	200HL	200HL
			52HL	54HL	44HL				77SL	78SL	64SL	77SL	78SL	64SL	Clear	Semi-frost narrow	Full frost wide
			55HL	60HL	48HL				85SL	85SL	70SL	85SL	85SL	70SL			
			60HL	74HL	54HL				54HL	54HL	46HL	54HL	54HL	46HL			
			76HL		65HL				57HL	57HL	48HL	57HL	57HL	48HL			
			Clear	Semi-frost narrow	Full frost wide				62HL	62HL	52HL	62HL	62HL	52HL			
									68HL	68HL	57HL	68HL	68HL	57HL			
									82HL	82HL	69HL	82HL	82HL	69HL			
									97HL	97HL	81HL	97HL	97HL	81HL			
									Clear	Semi-frost narrow	Full frost wide						

Notes

SL denotes standard lumen output, HL denotes high lumen output. Additional LEDs to obtain lumen package. For comparable lumen packages, HL efficacy is greater than SL efficacy.
 26SL: 2600 delivered lumens, standard lumen output
 170HL: 17000 delivered lumens, high output.
 (1) Nominal lumen values. See table for value and fixture length. (10) DALI and Step-dim versions require two drivers.

Notes

Same notes apply as round (column on left)

Lens	Voltage	Options	Color Temp / CCT		
Round LC=Clear Lens LN=Semi-Frost Lens - Narrow LW=Full Frost Lens - Wide Square SLC=Square / Flat Clear Lens SLN=Square / Flat Semi - Frost Lens - Narrow SLW=Square / Flat Full Frost Lens - Wide	UNV=Universal Voltage 120-277 347=347V (13),(14) 480=480V (2)	Emergency EL7W=7-watt, 120V-277V emergency battery pack installed (2),(5) EL14W=14-watt 120V-277V emergency battery pack installed (2),(5) GTR2=Bodine Generator Transfer Relay (6) ETRD=Iota Emergency Transfer Relay with dimming control (6)	Wiring PI/CPI=Plug in and cross over plug in options (8) PC6/515P=(NEMA 5-15P) 6 ft. Cord with NEMA Straight Plug (7),(8) PC6/L715=(NEMA L7-15P) 6 ft. Cord with NEMA Twist Plug (7),(8)	Motion Sensors (11) LB-ERMS360=360° Low Bay Motion Sensor - End of Row LB-MRMS360=360° Low Bay Motion Sensor - Middle of Row HB-ERMS360=360° High Bay Motion Sensor - End of Row (6) HB-MRMS360=360° High Bay Motion Sensor - Middle of Row (6)	CCT/CRI L830=3000K, 80 CRI L835=3500K, 80 CRI L840=4000K, 80 CRI L850=5000K, 80 CRI L930=3000K, 90 CRI L935=3500K, 90 CRI L940=4000K, 90 CRI L950=5000K, 90 CRI
	Notes (2) 4 ft. and 8 ft. only. (12) 347V CD driver is limited to 50W max output before requiring 2 drivers (no 85W 347V solution). (13) 347 SD Driver requires qty 2 transformers for Dual switch legs can not offer with EBP due to space requirements for 3 ed transformer for EBP charge circuit. (14) All other drivers at 347V requires single transformer for Driver. If EBP is included, would require second transformer THD an PF affected by transformer (no DLC).	Notes (2) 4 ft. and 8 ft. only. (3) Motion Sensor offers dimmability. (5) With integral test switch/indicator/laser test. For approximate delivered lumens multiply the lumens per watt of the desired fixture by the wattage of the emergency battery pack (100 lm/W x 7=700 lumens). IES-format photometry for luminaire under emergency operation available. (6) Used to bypass local control during outage. Must be used in conjunction with UL 1008 device (provided by others). GTR2 and ETR2 options include 2 relays on fixtures with dimming drivers. ETRD option only requires one relay when used on a dimming fixture. Must specify voltage as 120V or 277V when ordering these devices. (7) Most common C&P shown. Must specify location for cord. All "end" locations will be on the end with sensor installed. (8) Consult tech support on numerous options for this feature. (11) Sensors provided in separate externally mounted enclosure. See SRL spec sheet for fully integrated/connected sensors.			

Order Information (continued)

Driver Type	Number of Drivers	Packaging	Accessories
CD =0-10V Dimming Driver (10%-100% Dimming) HCD =0-10V Dimming Driver (1%-100% Dimming) SD =Step-dim (Bi Level) (2) SLTD =Fifth Light (DALI) Driver (2), (4)	1=1 Driver 2=2 Drivers	U =Unit Pack	Accessories (Order Separately) Round Replacement Lenses SNLED-LENS-LW-2FT-U =Replacement Lens 2 ft, Full Frost SNLED-LENS-LN-2FT-U =Replacement Lens 2 ft, Semi Frost SNLED-LENS-LC-2FT-U =Replacement Lens 2 ft, Clear SNLED-LENS-LW-4FT-U =Replacement Lens 4 ft, Full Frost SNLED-LENS-LN-4FT-U =Replacement Lens 4 ft, Semi Frost SNLED-LENS-LC-4FT-U =Replacement Lens 4 ft, Clear Square Replacement Lenses SNLED-SQLENS-SLW-2FT-U =Replacement Lens 2 ft, Full Frost SNLED-SQLENS-SLN-2FT-U =Replacement Lens 2 ft, Semi Frost SNLED-SQLENS-SLC-2FT-U =Replacement Lens 2 ft, Clear SNLED-SQLENS-SLW-4FT-U =Replacement Lens 4 ft, Full Frost SNLED-SQLENS-SLN-4FT-U =Replacement Lens 4 ft, Semi Frost SNLED-SQLENS-SLC-4FT-U =Replacement Lens 4 ft, Clear
Notes (2) 4 ft. and 8 ft. only. (4) For a complete listing of Fifth Light products, visit www.eaton.com/lightingsystems			

Product Specifications

Construction

- Die-formed of cold rolled steel with numerous knockouts for easy installation
- Groove for Tong Hanger
- Convertible end plate for continuous row alignment
- Channel/wireway cover secured with sheet metal screws
- Surface, pendant or stem mounting

Controls

- 0-10V dimming drivers to 10% or to 1% options
- Step-dimming option
- Fifth Light DALI 2.0 driver option

Electrical

- Long-life LED system with electrical driver for optimal performance
- LED's available in 3000K, 3500K, 4000K or 5000K with CRI of 80 standard or optional 90 CRI
- TM21 rating of L87>60,000 hours
- Electronic drivers available for 120-277V, 347V and 480 applications
- Operating temperature of -20°C to 40°C; Ideal for cold storage environments

Emergency Battery Pack Option

- Optional 120V-277V integral emergency battery pack available in 7W or 14W
- 7-watt battery provides approximately 900 lumens; 14-watt battery approximately 1800 lumens depending on efficacy
- 90-minute backup period for code compliance
- Test switch with laser pointer allows safe testing from floor
- Patented EZ Key prevents accidental discharge during construction
- Generator transfer options available

Finish

- Multi-stage, iron phosphate pretreatment
- Highly reflective paint after fabrication
- Standard baked white enamel finish

Shielding

- Three round lensed optical distributions available: Clear with linear ribs (LC), semi-frost for narrow distribution (LN) and full frost for wide distribution (LW)
- Three square lensed optical distributions available: clear with linear ribs (SLC), semi-frost for narrow distribution (SLN) and full frost for wide distribution (SLW)

Compliance

- cULus Listed for damp locations
- RoHS compliant
- State of California Title 24 high efficacy luminaire
- DesignLights Consortium® Qualified and classified for DLC Standard and DLC Premium (refer to www.designlights.org)
- Suitable for closet use when installed to NEC 410.16 spacings standards

Warranty

- Five year warranty

Photometric Data



Energy and Performance Data

CCT Table

Approximate Color Temperature	Multiplier
2700K	.93
3000K	.98
3500K	1.0
4000K	1.02
5000K	1.02

CRI

Lumen multiplier (80CRI to 90CRI)			
3000K	3500K	4000K	5000K
0.805	0.840	0.846	0.901

Shipping Data

Length	Wt.
2 ft.	4.3 lbs.
4 ft.	8.2 lbs.
8 ft.	15.1 lbs.

Energy and Performance Data

Wattage: Round Clear Lens

SNLED Type	Lumen Type	Length	Catalog Number**	Nominal 3500K Lumens	Wattage	lm/W
Clear Lens (LC)	Standard	2 ft.	2SNLED-LD5-18SL-LC-UNV-L8XX-CD1-U	1960	14	137.4
Clear Lens (LC)	Standard	2 ft.	2SNLED-LD5-22SL-LC-UNV-L8XX-CD1-U	2420	18	133.7
Clear Lens (LC)	Standard	2 ft.	2SNLED-LD5-26SL-LC-UNV-L8XX-CD1-U	2747	21	131.1
Clear Lens (LC)	High	2 ft.	2SNLED-LD5-34HL-LC-UNV-L8XX-CD1-U	3487	27	131.2
Clear Lens (LC)	Standard	4 ft.	4SNLED-LD5-18SL-LC-UNV-L8XX-CD1-U	1890	13	145.0
Clear Lens (LC)	Standard	4 ft.	4SNLED-LD5-22SL-LC-UNV-L8XX-CD1-U	2344	16	146.4
Clear Lens (LC)	Standard	4 ft.	4SNLED-LD5-26SL-LC-UNV-L8XX-CD1-U	2699	18	146.3
Clear Lens (LC)	Standard	4 ft.	4SNLED-LD5-30SL-LC-UNV-L8XX-CD1-U	3077	21	145.4
Clear Lens (LC)	Standard	4 ft.	4SNLED-LD5-34SL-LC-UNV-L8XX-CD1-U	3567	25	143.3
Clear Lens (LC)	Standard	4 ft.	4SNLED-LD5-37SL-LC-UNV-L8XX-CD1-U	3924	28	141.6
Clear Lens (LC)	Standard	4 ft.	4SNLED-LD5-41SL-LC-UNV-L8XX-CD1-U	4269	31	139.6
Clear Lens (LC)	Standard	4 ft.	4SNLED-LD5-46SL-LC-UNV-L8XX-CD1-U	4718	35	136.8
Clear Lens (LC)	Standard	4 ft.	4SNLED-LD5-49SL-LC-UNV-L8XX-CD1-U	5051	38	134.4
Clear Lens (LC)	Standard	4 ft.	4SNLED-LD5-52SL-LC-UNV-L8XX-CD1-U	5478	41	133.3
Clear Lens (LC)	Standard	4 ft.	4SNLED-LD5-56SL-LC-UNV-L8XX-CD1-U	5880	46	127.4
Clear Lens (LC)	Standard	4 ft.	4SNLED-LD5-63SL-LC-UNV-L8XX-CD1-U	6358	52	123.1
Clear Lens (LC)	Standard	4 ft.	4SNLED-LD5-66SL-LC-UNV-L8XX-CD1-U	6628	55	120.2
Clear Lens (LC)	High	4 ft.	4SNLED-LD5-52HL-LC-UNV-L8XX-CD1-U	5171	37	139.5
Clear Lens (LC)	High	4 ft.	4SNLED-LD5-55HL-LC-UNV-L8XX-CD1-U	5409	39	138.5
Clear Lens (LC)	High	4 ft.	4SNLED-LD5-60HL-LC-UNV-L8XX-CD1-U	5893	43	136.7
Clear Lens (LC)	High	4 ft.	4SNLED-LD5-76HL-LC-UNV-L8XX-CD1-U	7774	62	125.1
Clear Lens (LC)	Standard	8 ft.	8TSNLED-LD5-60SL-LC-UNV-L8XX-CD1-U	6154	42	145.4
Clear Lens (LC)	Standard	8 ft.	8TSNLED-LD5-68SL-LC-UNV-L8XX-CD1-U	7134	50	143.3
Clear Lens (LC)	Standard	8 ft.	8TSNLED-LD5-75SL-LC-UNV-L8XX-CD1-U	7847	55	141.6
Clear Lens (LC)	Standard	8 ft.	8TSNLED-LD5-83SL-LC-UNV-L8XX-CD1-U	8537	61	139.6
Clear Lens (LC)	Standard	8 ft.	8TSNLED-LD5-90SL-LC-UNV-L8XX-CD1-U	9437	69	136.8
Clear Lens (LC)	Standard	8 ft.	8TSNLED-LD5-98SL-LC-UNV-L8XX-CD1-U	10101	75	134.4
Clear Lens (LC)	Standard	8 ft.	8TSNLED-LD5-105SL-LC-UNV-L8XX-CD1-U	10956	82	133.3
Clear Lens (LC)	High	8 ft.	8TSNLED-LD5-130HL-LC-UNV-L8XX-CD1-U	11786	86	136.7
Clear Lens (LC)	High	8 ft.	8TSNLED-LD5-170HL-LC-UNV-L8XX-CD2-U	15549	124	125.1

* Consult factory for stock availability.

Energy and Performance Data

Wattage: Round Semi-frost Lens, Narrow

SNLED Type	Lumen Type	Length	Catalog Number**	Nominal 3500K Lumens	Wattage	lm/W
Semi-Frost Lens (LN)	Standard	2 ft.	2SNLED-LD5-18SL-LN-UNV-L8XX-CD1-U	1903	14	133.4
Semi-Frost Lens (LN)	Standard	2 ft.	2SNLED-LD5-22SL-LN-UNV-L8XX-CD1-U	2350	18	129.8
Semi-Frost Lens (LN)	Standard	2 ft.	2SNLED-LD5-26SL-LN-UNV-L8XX-CD1-U	2667	21	127.3
Semi-Frost Lens (LN)	High	2 ft.	2SNLED-LD5-32HL-LN-UNV-L8XX-CD1-U	3385	27	127.4
Semi-Frost Lens (LN)	Standard	4 ft.	4SNLED-LD5-18SL-LN-UNV-L8XX-CD1-U	1835	13	140.8
Semi-Frost Lens (LN)	Standard	4 ft.	4SNLED-LD5-22SL-LN-UNV-L8XX-CD1-U	2276	16	142.2
Semi-Frost Lens (LN)	Standard	4 ft.	4SNLED-LD5-26SL-LN-UNV-L8XX-CD1-U	2620	18	142.0
Semi-Frost Lens (LN)	Standard	4 ft.	4SNLED-LD5-30SL-LN-UNV-L8XX-CD1-U	2987	21	141.2
Semi-Frost Lens (LN)	Standard	4 ft.	4SNLED-LD5-34SL-LN-UNV-L8XX-CD1-U	3463	25	139.2
Semi-Frost Lens (LN)	Standard	4 ft.	4SNLED-LD5-37SL-LN-UNV-L8XX-CD1-U	3809	28	137.5
Semi-Frost Lens (LN)	Standard	4 ft.	4SNLED-LD5-41SL-LN-UNV-L8XX-CD1-U	4144	31	135.6
Semi-Frost Lens (LN)	Standard	4 ft.	4SNLED-LD5-46SL-LN-UNV-L8XX-CD1-U	4581	35	132.8
Semi-Frost Lens (LN)	Standard	4 ft.	4SNLED-LD5-49SL-LN-UNV-L8XX-CD1-U	4903	38	130.4
Semi-Frost Lens (LN)	Standard	4 ft.	4SNLED-LD5-53SL-LN-UNV-L8XX-CD1-U	5318	41	129.4
Semi-Frost Lens (LN)	Standard	4 ft.	4SNLED-LD5-56SL-LN-UNV-L8XX-CD1-U	5708	46	123.7
Semi-Frost Lens (LN)	Standard	4 ft.	4SNLED-LD5-61SL-LN-UNV-L8XX-CD1-U	6172	52	119.5
Semi-Frost Lens (LN)	Standard	4 ft.	4SNLED-LD5-64SL-LN-UNV-L8XX-CD1-U	6435	55	116.7
Semi-Frost Lens (LN)	High	4 ft.	4SNLED-LD5-50HL-LN-UNV-L8XX-CD1-U	5020	37	135.4
Semi-Frost Lens (LN)	High	4 ft.	4SNLED-LD5-54HL-LN-UNV-L8XX-CD1-U	5252	39	134.5
Semi-Frost Lens (LN)	High	4 ft.	4SNLED-LD5-60HL-LN-UNV-L8XX-CD1-U	5721	43	132.7
Semi-Frost Lens (LN)	High	4 ft.	4SNLED-LD5-74HL-LN-UNV-L8XX-CD1-U	7548	62	121.5
Semi-Frost Lens (LN)	Standard	8 ft.	8TSNLED-LD5-60SL-LN-UNV-L8XX-CD1-U	5975	42	141.2
Semi-Frost Lens (LN)	Standard	8 ft.	8TSNLED-LD5-68SL-LN-UNV-L8XX-CD1-U	6926	50	139.2
Semi-Frost Lens (LN)	Standard	8 ft.	8TSNLED-LD5-75SL-LN-UNV-L8XX-CD1-U	7619	55	137.5
Semi-Frost Lens (LN)	Standard	8 ft.	8TSNLED-LD5-83SL-LN-UNV-L8XX-CD1-U	8289	61	135.6
Semi-Frost Lens (LN)	Standard	8 ft.	8TSNLED-LD5-91SL-LN-UNV-L8XX-CD1-U	9162	69	132.8
Semi-Frost Lens (LN)	Standard	8 ft.	8TSNLED-LD5-98SL-LN-UNV-L8XX-CD1-U	9807	75	130.4
Semi-Frost Lens (LN)	Standard	8 ft.	8TSNLED-LD5-106SL-LN-UNV-L8XX-CD1-U	10636	82	129.4
Semi-Frost Lens (LN)	High	8 ft.	8TSNLED-LD5-130HL-LN-UNV-L8XX-CD1-U	11442	86	132.7
Semi-Frost Lens (LN)	High	8 ft.	8TSNLED-LD5-170HL-LN-UNV-L8XX-CD2-U	15095	124	121.5

* Consult factory for stock availability.

Energy and Performance Data

Wattage: Round Full-frost Lens, Wide

SNLED Type	Lumen Type	Length	Catalog Number**	Nominal 3500K Lumens	Wattage	lm/W
Full Frost Lens (LW)	Standard	2 ft.	2SNLED-LD5-16SL-LW-UNV-L8XX-CD1-U	1750	14	122.7
Full Frost Lens (LW)	Standard	2 ft.	2SNLED-LD5-20SL-LW-UNV-L8XX-CD1-U	2162	18	119.4
Full Frost Lens (LW)	Standard	2 ft.	2SNLED-LD5-23SL-LW-UNV-L8XX-CD1-U	2453	21	117.1
Full Frost Lens (LW)	High	2 ft.	2SNLED-LD5-30HL-LW-UNV-L8XX-CD1-U	2975	27	112.0
Full Frost Lens (LW)	Standard	4 ft.	4SNLED-LD5-16SL-LW-UNV-L8XX-CD1-U	1688	13	129.5
Full Frost Lens (LW)	Standard	4 ft.	4SNLED-LD5-20SL-LW-UNV-L8XX-CD1-U	2093	16	130.8
Full Frost Lens (LW)	Standard	4 ft.	4SNLED-LD5-23SL-LW-UNV-L8XX-CD1-U	2410	18	130.7
Full Frost Lens (LW)	Standard	4 ft.	4SNLED-LD5-27SL-LW-UNV-L8XX-CD1-U	2748	21	129.8
Full Frost Lens (LW)	Standard	4 ft.	4SNLED-LD5-30SL-LW-UNV-L8XX-CD1-U	3186	25	128.0
Full Frost Lens (LW)	Standard	4 ft.	4SNLED-LD5-33SL-LW-UNV-L8XX-CD1-U	3504	28	126.5
Full Frost Lens (LW)	Standard	4 ft.	4SNLED-LD5-37SL-LW-UNV-L8XX-CD1-U	3812	31	124.7
Full Frost Lens (LW)	Standard	4 ft.	4SNLED-LD5-41SL-LW-UNV-L8XX-CD1-U	4214	35	122.1
Full Frost Lens (LW)	Standard	4 ft.	4SNLED-LD5-44SL-LW-UNV-L8XX-CD1-U	4511	38	120.0
Full Frost Lens (LW)	Standard	4 ft.	4SNLED-LD5-47SL-LW-UNV-L8XX-CD1-U	4892	41	119.1
Full Frost Lens (LW)	Standard	4 ft.	4SNLED-LD5-50SL-LW-UNV-L8XX-CD1-U	5251	46	113.8
Full Frost Lens (LW)	Standard	4 ft.	4SNLED-LD5-56SL-LW-UNV-L8XX-CD1-U	5678	52	109.9
Full Frost Lens (LW)	Standard	4 ft.	4SNLED-LD5-58SL-LW-UNV-L8XX-CD1-U	5920	55	107.3
Full Frost Lens (LW)	High	4 ft.	4SNLED-LD5-44HL-LW-UNV-L8XX-CD1-U	4412	37	119.0
Full Frost Lens (LW)	High	4 ft.	4SNLED-LD5-48HL-LW-UNV-L8XX-CD1-U	4615	39	118.2
Full Frost Lens (LW)	High	4 ft.	4SNLED-LD5-54HL-LW-UNV-L8XX-CD1-U	5028	43	116.6
Full Frost Lens (LW)	High	4 ft.	4SNLED-LD5-65HL-LW-UNV-L8XX-CD1-U	6633	62	106.7
Full Frost Lens (LW)	Standard	8 ft.	8TSNLED-LD5-54SL-LW-UNV-L8XX-CD1-U	5496	42	129.8
Full Frost Lens (LW)	Standard	8 ft.	8TSNLED-LD5-61SL-LW-UNV-L8XX-CD1-U	6371	50	128.0
Full Frost Lens (LW)	Standard	8 ft.	8TSNLED-LD5-67SL-LW-UNV-L8XX-CD1-U	6371	50	128.0
Full Frost Lens (LW)	Standard	8 ft.	8TSNLED-LD5-74SL-LW-UNV-L8XX-CD1-U	7625	61	124.7
Full Frost Lens (LW)	Standard	8 ft.	8TSNLED-LD5-81SL-LW-UNV-L8XX-CD1-U	8428	69	122.1
Full Frost Lens (LW)	Standard	8 ft.	8TSNLED-LD5-88SL-LW-UNV-L8XX-CD1-U	9022	75	120.0
Full Frost Lens (LW)	Standard	8 ft.	8TSNLED-LD5-95SL-LW-UNV-L8XX-CD1-U	9785	82	119.1
Full Frost Lens (LW)	High	8 ft.	8TSNLED-LD5-110HL-LW-UNV-L8XX-CD1-U	11356	103	109.9
Full Frost Lens (LW)	High	8 ft.	8TSNLED-LD5-150HL-LW-UNV-L8XX-CD2-U	15739	158	99.5

* Consult factory for stock availability.

Energy and Performance Data

Wattage: Square Flat Clear Lens

SNLED Type	Lumen Type	Length	Catalog Number**	Nominal 3500K Lumens	Wattage	lm/W
Flat Clear Lens (SLC)	Standard	2 ft.	2SNLED-LD5-19SL-SLC-UNV-L8XX-CD1-U	1936	14	135.7
Flat Clear Lens (SLC)	Standard	2 ft.	2SNLED-LD5-24SL-SLC-UNV-L8XX-CD1-U	2391	18	132.1
Flat Clear Lens (SLC)	Standard	2 ft.	2SNLED-LD5-27SL-SLC-UNV-L8XX-CD1-U	2714	21	129.5
Flat Clear Lens (SLC)	High	2 ft.	2SNLED-LD5-37HL-SLC-UNV-L8XX-CD1-U	3669	27	138.1
Flat Clear Lens (SLC)	High	2 ft.	2SNLED-LD5-48HL-SLC-UNV-L8XX-CD1-U	4830	36	134.5
Flat Clear Lens (SLC)	Standard	4 ft.	4SNLED-LD5-19SL-SLC-UNV-L8XX-CD1-U	1868	13	143.3
Flat Clear Lens (SLC)	Standard	4 ft.	4SNLED-LD5-23SL-SLC-UNV-L8XX-CD1-U	2316	16	144.7
Flat Clear Lens (SLC)	Standard	4 ft.	4SNLED-LD5-27SL-SLC-UNV-L8XX-CD1-U	2666	18	144.5
Flat Clear Lens (SLC)	Standard	4 ft.	4SNLED-LD5-30SL-SLC-UNV-L8XX-CD1-U	3040	21	143.6
Flat Clear Lens (SLC)	Standard	4 ft.	4SNLED-LD5-35SL-SLC-UNV-L8XX-CD1-U	3524	25	141.6
Flat Clear Lens (SLC)	Standard	4 ft.	4SNLED-LD5-39SL-SLC-UNV-L8XX-CD1-U	3876	28	139.9
Flat Clear Lens (SLC)	Standard	4 ft.	4SNLED-LD5-42SL-SLC-UNV-L8XX-CD1-U	4217	31	138.0
Flat Clear Lens (SLC)	Standard	4 ft.	4SNLED-LD5-47SL-SLC-UNV-L8XX-CD1-U	4662	35	135.1
Flat Clear Lens (SLC)	Standard	4 ft.	4SNLED-LD5-50SL-SLC-UNV-L8XX-CD1-U	4990	38	132.7
Flat Clear Lens (SLC)	Standard	4 ft.	4SNLED-LD5-54SL-SLC-UNV-L8XX-CD1-U	5412	41	131.7
Flat Clear Lens (SLC)	Standard	4 ft.	4SNLED-LD5-58SL-SLC-UNV-L8XX-CD1-U	5809	46	125.9
Flat Clear Lens (SLC)	Standard	4 ft.	4SNLED-LD5-63SL-SLC-UNV-L8XX-CD1-U	6281	52	121.6
Flat Clear Lens (SLC)	Standard	4 ft.	4SNLED-LD5-65SL-SLC-UNV-L8XX-CD1-U	6549	55	118.7
Flat Clear Lens (SLC)	Standard	4 ft.	4SNLED-LD5-77SL-SLC-UNV-L8XX-CD1-U	7697	70	110.0
Flat Clear Lens (SLC)	Standard	4 ft.	4SNLED-LD5-85SL-SLC-UNV-L8XX-CD1-U	8490	85	100.4
Flat Clear Lens (SLC)	High	4 ft.	4SNLED-LD5-54HL-SLC-UNV-L8XX-CD1-U	5441	37	146.8
Flat Clear Lens (SLC)	High	4 ft.	4SNLED-LD5-57HL-SLC-UNV-L8XX-CD1-U	5692	39	145.7
Flat Clear Lens (SLC)	High	4 ft.	4SNLED-LD5-62HL-SLC-UNV-L8XX-CD1-U	6201	43	143.8
Flat Clear Lens (SLC)	High	4 ft.	4SNLED-LD5-68HL-SLC-UNV-L8XX-CD1-U	6795	48	140.8
Flat Clear Lens (SLC)	High	4 ft.	4SNLED-LD5-82HL-SLC-UNV-L8XX-CD1-U	8181	62	131.7
Flat Clear Lens (SLC)	High	4 ft.	4SNLED-LD5-97HL-SLC-UNV-L8XX-CD1-U	9705	79	122.7
Flat Clear Lens (SLC)	Standard	8 ft.	8TSNLED-LD5-60SL-SLC-UNV-L8XX-CD1-U	6080	42	143.6
Flat Clear Lens (SLC)	Standard	8 ft.	8TSNLED-LD5-70SL-SLC-UNV-L8XX-CD1-U	7048	50	141.6
Flat Clear Lens (SLC)	Standard	8 ft.	8TSNLED-LD5-78SL-SLC-UNV-L8XX-CD1-U	7753	50	139.9
Flat Clear Lens (SLC)	Standard	8 ft.	8TSNLED-LD5-84SL-SLC-UNV-L8XX-CD1-U	8435	61	138.0
Flat Clear Lens (SLC)	Standard	8 ft.	8TSNLED-LD5-93SL-SLC-UNV-L8XX-CD1-U	9323	69	135.1
Flat Clear Lens (SLC)	Standard	8 ft.	8TSNLED-LD5-100SL-SLC-UNV-L8XX-CD1-U	9980	75	132.7
Flat Clear Lens (SLC)	Standard	8 ft.	8TSNLED-LD5-108SL-SLC-UNV-L8XX-CD1-U	10824	82	131.7
Flat Clear Lens (SLC)	Standard	8 ft.	8TSNLED-LD5-116SL-SLC-UNV-L8XX-CD1-U	11618	61	125.9
Flat Clear Lens (SLC)	Standard	8 ft.	8TSNLED-LD5-125SL-SLC-UNV-L8XX-CD1-U	12562	69	121.6
Flat Clear Lens (SLC)	Standard	8 ft.	8TSNLED-LD5-131SL-SLC-UNV-L8XX-CD1-U	13097	75	118.7
Flat Clear Lens (SLC)	High	8 ft.	8TSNLED-LD5-130HL-SLC-UNV-L8XX-CD1-U	12402	82	143.8
Flat Clear Lens (SLC)	High	8 ft.	8TSNLED-LD5-170HL-SLC-UNV-L8XX-CD1-U	16361	103	131.7
Flat Clear Lens (SLC)	High	8 ft.	8TSNLED-LD5-200HL-SLC-UNV-L8XX-CD1-U	19411	158	122.7

* Consult factory for stock availability.

Energy and Performance Data

Wattage: Square Flat Semi-frost Lens, Narrow

SNLED Type	Lumen Type	Length	Catalog Number**	Nominal 3500K Lumens	Wattage	lm/W
Flat Semi-frost Lens (SLN)	Standard	2 ft.	2SNLED-LD5-19SL-SLN-UNV-L8XX-CD1-U	1931	14	135.3
Flat Semi-frost Lens (SLN)	Standard	2 ft.	2SNLED-LD5-24SL-SLN-UNV-L8XX-CD1-U	2385	18	131.7
Flat Semi-frost Lens (SLN)	Standard	2 ft.	2SNLED-LD5-27SL-SLN-UNV-L8XX-CD1-U	2706	21	129.1
Flat Semi-frost Lens (SLN)	High	2 ft.	2SNLED-LD5-37HL-SLN-UNV-L8XX-CD1-U	3659	27	137.7
Flat Semi-frost Lens (SLN)	High	2 ft.	2SNLED-LD5-48HL-SLN-UNV-L8XX-CD1-U	4816	36	134.2
Flat Semi-frost Lens (SLN)	Standard	4 ft.	4SNLED-LD5-19SL-SLN-UNV-L8XX-CD1-U	1863	13	142.9
Flat Semi-frost Lens (SLN)	Standard	4 ft.	4SNLED-LD5-23SL-SLN-UNV-L8XX-CD1-U	2309	16	144.3
Flat Semi-frost Lens (SLN)	Standard	4 ft.	4SNLED-LD5-27SL-SLN-UNV-L8XX-CD1-U	2659	18	144.1
Flat Semi-frost Lens (SLN)	Standard	4 ft.	4SNLED-LD5-30SL-SLN-UNV-L8XX-CD1-U	3032	21	143.2
Flat Semi-frost Lens (SLN)	Standard	4 ft.	4SNLED-LD5-35SL-SLN-UNV-L8XX-CD1-U	3514	25	141.2
Flat Semi-frost Lens (SLN)	Standard	4 ft.	4SNLED-LD5-39SL-SLN-UNV-L8XX-CD1-U	3866	28	139.5
Flat Semi-frost Lens (SLN)	Standard	4 ft.	4SNLED-LD5-42SL-SLN-UNV-L8XX-CD1-U	4206	31	137.6
Flat Semi-frost Lens (SLN)	Standard	4 ft.	4SNLED-LD5-46SL-SLN-UNV-L8XX-CD1-U	4649	35	134.7
Flat Semi-frost Lens (SLN)	Standard	4 ft.	4SNLED-LD5-50SL-SLN-UNV-L8XX-CD1-U	4976	38	132.4
Flat Semi-frost Lens (SLN)	Standard	4 ft.	4SNLED-LD5-54SL-SLN-UNV-L8XX-CD1-U	5397	41	131.4
Flat Semi-frost Lens (SLN)	Standard	4 ft.	4SNLED-LD5-58SL-SLN-UNV-L8XX-CD1-U	5793	46	125.6
Flat Semi-frost Lens (SLN)	Standard	4 ft.	4SNLED-LD5-63SL-SLN-UNV-L8XX-CD1-U	6264	52	121.3
Flat Semi-frost Lens (SLN)	Standard	4 ft.	4SNLED-LD5-65SL-SLN-UNV-L8XX-CD1-U	6530	55	118.4
Flat Semi-frost Lens (SLN)	Standard	4 ft.	4SNLED-LD5-78SL-SLN-UNV-L8XX-CD1-U	7676	70	109.7
Flat Semi-frost Lens (SLN)	Standard	4 ft.	4SNLED-LD5-85SL-SLN-UNV-L8XX-CD1-U	8466	85	100.1
Flat Semi-frost Lens (SLN)	High	4 ft.	4SNLED-LD5-54HL-SLN-UNV-L8XX-CD1-U	5426	37	146.4
Flat Semi-frost Lens (SLN)	High	4 ft.	4SNLED-LD5-57HL-SLN-UNV-L8XX-CD1-U	5676	39	145.3
Flat Semi-frost Lens (SLN)	High	4 ft.	4SNLED-LD5-62HL-SLN-UNV-L8XX-CD1-U	6184	43	143.4
Flat Semi-frost Lens (SLN)	High	4 ft.	4SNLED-LD5-68HL-SLN-UNV-L8XX-CD1-U	6776	48	140.5
Flat Semi-frost Lens (SLN)	High	4 ft.	4SNLED-LD5-82HL-SLN-UNV-L8XX-CD1-U	8158	62	131.3
Flat Semi-frost Lens (SLN)	High	4 ft.	4SNLED-LD5-97HL-SLN-UNV-L8XX-CD1-U	9679	79	122.4
Flat Semi-frost Lens (SLN)	Standard	8 ft.	8TSNLED-LD5-64SL-SLN-UNV-L8XX-CD1-U	6063	42	143.2
Flat Semi-frost Lens (SLN)	Standard	8 ft.	8TSNLED-LD5-70SL-SLN-UNV-L8XX-CD1-U	7028	50	141.2
Flat Semi-frost Lens (SLN)	Standard	8 ft.	8TSNLED-LD5-77SL-SLN-UNV-L8XX-CD1-U	7731	55	139.5
Flat Semi-frost Lens (SLN)	Standard	8 ft.	8TSNLED-LD5-84SL-SLN-UNV-L8XX-CD1-U	8411	61	137.6
Flat Semi-frost Lens (SLN)	Standard	8 ft.	8TSNLED-LD5-93SL-SLN-UNV-L8XX-CD1-U	9297	69	134.7
Flat Semi-frost Lens (SLN)	Standard	8 ft.	8TSNLED-LD5-100SL-SLN-UNV-L8XX-CD1-U	9952	75	132.4
Flat Semi-frost Lens (SLN)	Standard	8 ft.	8TSNLED-LD5-108SL-SLN-UNV-L8XX-CD1-U	10794	82	131.4
Flat Semi-frost Lens (SLN)	Standard	8 ft.	8TSNLED-LD5-116SL-SLN-UNV-L8XX-CD1-U	11586	92	125.6
Flat Semi-frost Lens (SLN)	Standard	8 ft.	8TSNLED-LD5-125SL-SLN-UNV-L8XX-CD2-U	12527	103	121.3
Flat Semi-frost Lens (SLN)	Standard	8 ft.	8TSNLED-LD5-130SL-SLN-UNV-L8XX-CD2-U	13061	110	118.4
Flat Semi-frost Lens (SLN)	High	8 ft.	8TSNLED-LD5-130HL-SLN-UNV-L8XX-CD2-U	12368	86	143.4
Flat Semi-frost Lens (SLN)	High	8 ft.	8TSNLED-LD5-170HL-SLN-UNV-L8XX-CD2-U	16316	124	131.3
Flat Semi-frost Lens (SLN)	High	8 ft.	8TSNLED-LD5-200HL-SLN-UNV-L8XX-CD2-U	19357	158	122.4

* Consult factory for stock availability.

Energy and Performance Data

Wattage: Square Flat Full-frost Lens, Wide

SNLED Type	Lumen Type	Length	Catalog Number**	Nominal 3500K Lumens	Wattage	lm/W
Flat Full-frost Lens (SLW)	Standard	2 ft.	2SNLED-LD5-16SL-SLW-UNV-L8XX-CD1-U	1604	14	112.4
Flat Full-frost Lens (SLW)	Standard	2 ft.	2SNLED-LD5-20SL-SLW-UNV-L8XX-CD1-U	1981	18	109.4
Flat Full-frost Lens (SLW)	Standard	2 ft.	2SNLED-LD5-22SL-SLW-UNV-L8XX-CD1-U	2248	21	107.3
Flat Full-frost Lens (SLW)	High	2 ft.	2SNLED-LD5-30HL-SLW-UNV-L8XX-CD1-U	3077	27	115.8
Flat Full-frost Lens (SLW)	High	2 ft.	2SNLED-LD5-41HL-SLW-UNV-L8XX-CD1-U	4051	36	
Flat Full-frost Lens (SLW)	Standard	4 ft.	4SNLED-LD5-15SL-SLW-UNV-L8XX-CD1-U	1547	13	118.7
Flat Full-frost Lens (SLW)	Standard	4 ft.	4SNLED-LD5-19SL-SLW-UNV-L8XX-CD1-U	1918	16	119.8
Flat Full-frost Lens (SLW)	Standard	4 ft.	4SNLED-LD5-22SL-SLW-UNV-L8XX-CD1-U	2209	18	119.7
Flat Full-frost Lens (SLW)	Standard	4 ft.	4SNLED-LD5-25SL-SLW-UNV-L8XX-CD1-U	2518	21	119.0
Flat Full-frost Lens (SLW)	Standard	4 ft.	4SNLED-LD5-29SL-SLW-UNV-L8XX-CD1-U	2919	25	117.3
Flat Full-frost Lens (SLW)	Standard	4 ft.	4SNLED-LD5-32SL-SLW-UNV-L8XX-CD1-U	3211	28	115.9
Flat Full-frost Lens (SLW)	Standard	4 ft.	4SNLED-LD5-35SL-SLW-UNV-L8XX-CD1-U	3494	31	114.3
Flat Full-frost Lens (SLW)	Standard	4 ft.	4SNLED-LD5-39SL-SLW-UNV-L8XX-CD1-U	3862	35	111.9
Flat Full-frost Lens (SLW)	Standard	4 ft.	4SNLED-LD5-41SL-SLW-UNV-L8XX-CD1-U	4134	38	110.0
Flat Full-frost Lens (SLW)	Standard	4 ft.	4SNLED-LD5-45SL-SLW-UNV-L8XX-CD1-U	4483	41	109.1
Flat Full-frost Lens (SLW)	Standard	4 ft.	4SNLED-LD5-48SL-SLW-UNV-L8XX-CD1-U	4812	46	104.3
Flat Full-frost Lens (SLW)	Standard	4 ft.	4SNLED-LD5-52SL-SLW-UNV-L8XX-CD1-U	5203	52	100.7
Flat Full-frost Lens (SLW)	Standard	4 ft.	4SNLED-LD5-54SL-SLW-UNV-L8XX-CD1-U	5425	55	98.4
Flat Full-frost Lens (SLW)	Standard	4 ft.	4SNLED-LD5-64SL-SLW-UNV-L8XX-CD1-U	6376	70	91.1
Flat Full-frost Lens (SLW)	Standard	4 ft.	4SNLED-LD5-70SL-SLW-UNV-L8XX-CD1-U	7033	48	83.1
Flat Full-frost Lens (SLW)	High	4 ft.	4SNLED-LD5-46HL-SLW-UNV-L8XX-CD1-U	4564	37	123.1
Flat Full-frost Lens (SLW)	High	4 ft.	4SNLED-LD5-48HL-SLW-UNV-L8XX-CD1-U	4774	39	122.2
Flat Full-frost Lens (SLW)	High	4 ft.	4SNLED-LD5-52HL-SLW-UNV-L8XX-CD1-U	5201	43	120.6
Flat Full-frost Lens (SLW)	High	4 ft.	4SNLED-LD5-57HL-SLW-UNV-L8XX-CD1-U	5699	48	118.1
Flat Full-frost Lens (SLW)	High	4 ft.	4SNLED-LD5-69HL-SLW-UNV-L8XX-CD1-U	6862	62	110.4
Flat Full-frost Lens (SLW)	High	4 ft.	4SNLED-LD5-81HL-SLW-UNV-L8XX-CD1-U	8141	79	102.9
Flat Full-frost Lens (SLW)	Standard	8 ft.	8TSNLED-LD5-50SL-SLW-UNV-L8XX-CD1-U	5037	42	119.0
Flat Full-frost Lens (SLW)	Standard	8 ft.	8TSNLED-LD5-58SL-SLW-UNV-L8XX-CD1-U	5838	50	117.3
Flat Full-frost Lens (SLW)	Standard	8 ft.	8TSNLED-LD5-64SL-SLW-UNV-L8XX-CD1-U	6422	55	115.9
Flat Full-frost Lens (SLW)	Standard	8 ft.	8TSNLED-LD5-70SL-SLW-UNV-L8XX-CD1-U	6987	61	114.3
Flat Full-frost Lens (SLW)	Standard	8 ft.	8TSNLED-LD5-77SL-SLW-UNV-L8XX-CD1-U	7723	69	111.9
Flat Full-frost Lens (SLW)	Standard	8 ft.	8TSNLED-LD5-83SL-SLW-UNV-L8XX-CD1-U	8267	75	110.0
Flat Full-frost Lens (SLW)	Standard	8 ft.	8TSNLED-LD5-90SL-SLW-UNV-L8XX-CD1-U	8966	82	109.1
Flat Full-frost Lens (SLW)	Standard	8 ft.	8TSNLED-LD5-96SL-SLW-UNV-L8XX-CD1-U	9624	92	104.3
Flat Full-frost Lens (SLW)	Standard	8 ft.	8TSNLED-LD5-104SL-SLW-UNV-L8XX-CD1-U	10406	103	100.7
Flat Full-frost Lens (SLW)	Standard	8 ft.	8TSNLED-LD5-108SL-SLW-UNV-L8XX-CD1-U	10850	110	98.4
Flat Full-frost Lens (SLW)	High	8 ft.	8TSNLED-LD5-130HL-SLW-UNV-L8XX-CD1-U	10402	86	120.6
Flat Full-frost Lens (SLW)	High	8 ft.	8TSNLED-LD5-170HL-SLW-UNV-L8XX-CD1-U	13723	124	110.4
Flat Full-frost Lens (SLW)	High	8 ft.	8TSNLED-LD5-200HL-SLW-UNV-L8XX-CD1-U	16281	158	102.9

* Consult factory for stock availability.

Dimensional and Mounting Details

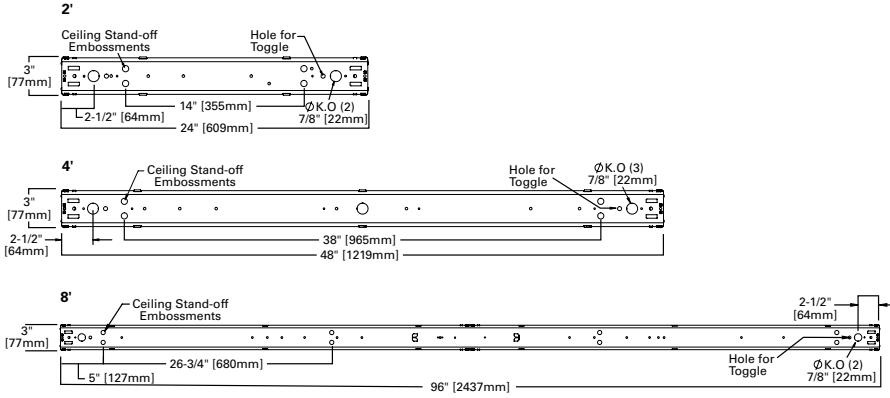

601471-LED

SPECIFICATION SHEET

PROJECT		
DATE		TYPE

Sophisticated LED technology meets indoor wall sconce fixture

- Gold interior with black metal details or silver interior with white metal details
- Dimmable with ELV dimmer (Not included)
- 120V

Color Temp 3000K
 CRI (Ra) >90
 Dimming 100% - 10%
 Rated Life 50,000 hours

Voltage	Watt	LED Lumens	Delivered Lumens	Finish(es)
120V	8W	600lm*	153lm	BK -Black
120V	8W	600lm*	103lm	WH-White



601471WH-LED

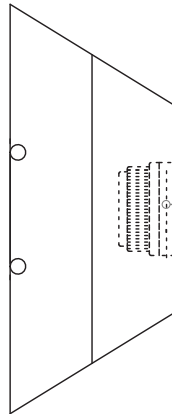

Silver Interior or Gold Interior
 LED Engine
 Metal Finish
 BK - Black
 WH - White

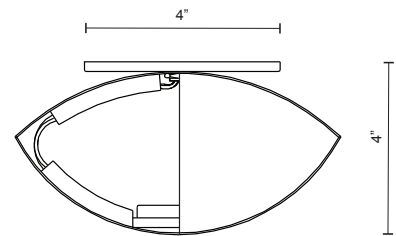
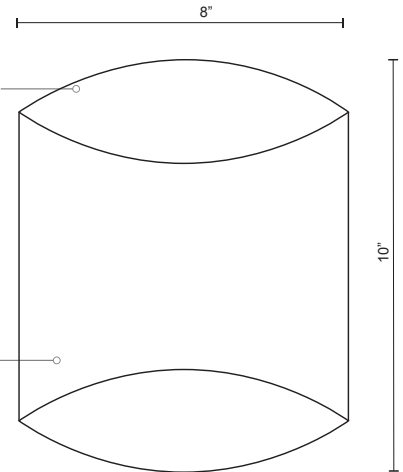

601471BK-LED



601471WH-LED

KUZCO
 LIGHTING

20150121

19054 28th Avenue
 Surrey, BC, Canada
 V3Z 6M3

T: 604 538 7162
 F: 604 538 7196
 W: Kuzcolighting.com



Catalog Number
Notes
Type

FEATURES & SPECIFICATIONS

INTENDED USE — Provides a minimum of 90 minutes illumination for the rated wattage upon loss of AC power to meet and exceed code required emergency lighting. Ideal for applications requiring attractive LED unit equipment with quick installation and unparalleled performance for mounting heights from 7.5' to 30'. **Certain airborne contaminants can diminish the integrity of acrylic and/or polycarbonate.** [Click here for Acrylic-Polycarbonate Compatibility table for suitable uses.](#)

CONSTRUCTION — The housing is a standard white (black optional) thermoplastic with a compact and low-profile contemporary design. It is 5VA flame rated, impact-resistant, scratch-resistant and corrosion proof. The UV-stable resin resists discoloration from natural and man-made light sources. There is a low-profile, integrated and back-lit test switch with an easily visible multi-color LED status indicator. The back-plate contains a universal j-box mounting pattern to facilitate ease of installation on a wide variety of j-boxes and the front housing allows tool-less access for ease of maintenance.

The lamp heads have a unique track-and-swivel arrangement permitting full range of direction of optical aiming.

OPTICS — The ELM4L features two high-performance LEDs rated at 3.3 watts per lamp head and delivers a total of 640 lumens in a spot pattern (SP640L).

The ELM6L features three high-performance LEDs rated at 5.3 watts per lamp head and delivers a total of 1,100 lumens in a spot pattern (SP1100L).

The typical life of an LED is 10 years. The LED light sources typically never need to be replaced under normal conditions for normal off applications.

CCT: 5000K

ELECTRICAL — Orderable in multiple voltages (see ordering tree for specific voltages.)

Current-limiting charger maximizes battery life and minimizes energy consumption to provide low operating costs. Small battery chargers Certified in the CA Title 20 Appliance Efficiency Database.

Short-circuit protection — current-limiting charger circuitry protects printed circuit board from shorts.

Regulated charge voltage maintains a stable charge voltage over a wide range of line voltages.

Prevents over/undercharging that shortens battery life and reduces capacity. Filtered charger input minimizes charge voltage ripple and extends battery life.

BATTERY: Sealed, maintenance-free nickel-cadmium (ELM4L only) or Lithium Iron Phosphate battery. Optional High-Output (HO option) and Extra High Output (EHO option), LTP battery type only, provides a wide variety of remote capacities and/or extended run-times.

SELF-DIAGNOSTICS and REMOTE TEST (SDRT option):

Automatic 24-hour recharge after a 90-minute discharge.

Advanced electrical design provides constant light output throughout the entire discharge period.

Brownout protection is automatically switched to emergency mode when supply voltage drops below approximately 80 percent nominal of 120, 220, 277 or 347. Other input voltages may vary.

AC/LVD reset allows battery connection before AC power is applied and prevents battery damage from deep discharge.

Self-Diagnostics: Continuously monitors AC functionality. Test switch and remote tester (RTKIT accessory) provide manual activation of 30-second diagnostic testing for on-demand visual inspection. Standard derangement monitoring will indicate disconnected battery, charger failure and displays green flashing indicator light while in emergency mode. Single multi-chromatic LED indicator to display two-state charging, test activation and three-state self-diagnostics.

Self-diagnostic testing: Five minutes every 30 days and 90 minutes annually. Diagnostic evaluation of lamps, AC to DC transfer, battery charging and condition of microprocessor. Automatic test is easily postponed for eight hours by activating manual test switch or use of remote tester (RTKIT accessory).

INSTALLATION — Wall and ceiling mount standard. Blind-mate connector ensures easy installation and safe maintenance. 7/8" entrance provision at top of unit for standard 1/2" conduit entry. Tool-less removal of front cover from back-plate for ease of installation and maintenance.

LISTINGS — UL damp location listed standard and wet location listed when used with the WPVS accessory, all at 50-104°F (10-40°C). Meets or exceeds all applicable requirements for UL 924, NFPA 101 (current Life Safety code), NFPA 70 (NEC), NOM (Norma Oficial Mexicana), California Energy Commission Title 20 section 1605.3 (W)(4), FCC Title 47, Part 15, Subpart B and OSHA. List and labeled to comply with Canadian Standards C22.2 No. 141-10.

WARRANTY — 5-year limited warranty. Complete warranty terms located at: www.acuitybrands.com/support/customer-support/terms-and-conditions

NOTE: Actual performance may differ as a result of end-user environment and application. All values are design or typical values, measured under laboratory conditions at 25 °C. Specifications subject to change without notice.

† Small Battery Chargers Certified in the CA Title 20 Appliance Efficiency Database.



EMERGENCY



Contemporary Commercial LED Emergency Light



ELM4L
640 Lumens

ELM6L
1100 Lumens

LITHIUM IRON PHOSPHATE
NICKEL CADMIUM



MOUNTING

All dimensions are inches (centimeters) unless otherwise indicated.

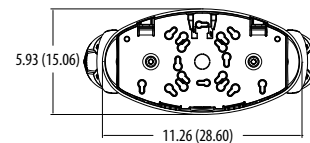
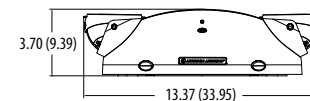
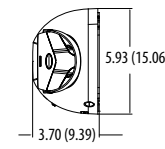
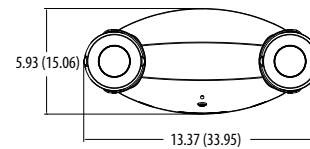

Specifications

- Length: 13 3/8 (33.95)
- Depth: 3 45/64 (9.39)
- Height: 5 15/16 (15.06)
- Weight: ELM4L 3 lb (1.4kg)
- Weight: ELM6L 3 lb (1.4kg)
- Weight: ELM6L HO 3.5 lbs (1.59 kg)
- Weight: ELM6L EHO 3.75 lbs (1.7 kg)

ELM4L-ELM6L Quantum® LED Contemporary Commercial Emergency Light



Looking for Contractor Select readily available configurations? Click here to visit Contractor Select™ spec sheet or go to www.contractorselect.com

NICKEL CADMIUM BATTERY MODELS

ORDERING INFORMATION For shortest lead times, configure product using **bolded options**.

Example: ELM4L

Series	Lamp Type	Housing Color	Voltage	Battery Type	Automatic Testing	Options
ELM4L ¹	640 lumens, adjustable optics	(blank) SP640L 640 lumen, 6.6 watt, Spot Pattern, two lamp	(blank) 120-277 VAC, 50/60Hz UVOLT 120 - 347 VAC, 50/60Hz	(blank) Nicad	(blank) None	(blank) none WPVS Wet protective vandal shield ² USPOM Assembled in the US PM Pendant Mount ³

Notes

- Does not support remote loads.
- Must be ordered when using for wet location applications.. WPVS breaks out and ships separately and color will match (ex: WPVS LRG B). Decreases delivered lumens up to 20%. See spec sheet [WPVS](#) for more information.
- Pendant mount option will include a 12" long 3/8-16 UNC threaded rod and hardware. Not available with any other lengths.

LITHIUM IRON PHOSPHATE BATTERY MODELS

ORDERING INFORMATION For shortest lead times, configure product using **bolded options**.

Example: ELM6L UVOLT LTP SDRT

Series ¹	Lamp Type	Housing Color	Voltage	Battery Type	Automatic Testing	Options
ELM4L	640 lumens, adjustable optics	(blank) SP640L 640 lumen, 6.6 watt, Spot Pattern, two lamp	UVOLT 120 - 347 VAC, 50/60Hz	LTP Lithium Iron Phosphate	(blank) none ² SDRT Self-diagnostics, remote test	LLH Less lamp heads ³
ELM6L	1100 lumens, adjustable optics	(blank) SP1100L 1100 lumen, 10.6 watt, Spot Pattern, two lamp				HO High-output battery

Notes

- Extended run-time or remote capacity is standard. New ELMRE and ELMRW style remotes are compatible with both SDRT and non-SDRT versions (see page 3).
- Only available with ELM4L.
- ELM4L with LLH (less lamp heads) not available with SDRT. ELM6L with LLH only available with SDRT.
- Must be ordered when using for wet location applications. WPVS breaks out and ships separately and color will match (ex: WPVS LRG B). Decreases delivered lumens up to 20%. See spec sheet [WPVS](#) for more information.
- Pendant mount option will include a 12" long 3/8-16 UNC threaded rod and hardware. Not available with any other lengths.

Other Accessories: Order as separate catalog number.

WPVS LRG W	Wet protective vandal shield, white (must be used for wet location applications)
WPVS LRG B	Wet protective vandal shield, black (must be used for wet location applications)
ELA WG1	Wireguard, 13 3/4"H x 15 1/4"W x 6"D (see spec sheet ELA-WG).
RTKIT	Remote test kit, up to 40' away (includes goggles, laser and battery)



ELM4L-ELM6L mounted inside the WPVS



ELM4L_ELM6L

EMERGENCY: One Lithonia Way, Conyers, GA 30012 Phone: 1-800-705-SERV (7378) techsupport-emergency@acuitybrands.com www.lithonia.com

© 2018-2020 Acuity Brands Lighting, Inc. All rights reserved. Rev. 04/21/20
Pg. 2 of 5

ELM4L-ELM6L Quantum® LED Contemporary Commercial Emergency Light

SPACING GUIDELINES

*Note: To see complete photometric report or download the .ies file for this product, visit Lithonia Lighting ELM4L and ELM6L home page.

Maximum Spacing Guidelines — ELM4L ¹						
Mounting Height	Illumination Level	Single Luminaire		Multiple Luminaire		Application Notes
		3' Path of Egress	6' Path of Egress	3' Path of Egress	6' Path of Egress	
7.5'	1FC Avg ¹	62'	58'	67'	60'	100' Corridor, 8' wide, and 12' high with 80/50/20 reflectances
10'	1FC Avg ¹	62'	58'	67'	60'	
7.5'	1FC Avg ¹	52'	40'	66'	58'	Retail open area: 200' X 15' X 30' with 80/50/20 reflectances
10'	1FC Avg ¹	52'	48'	64'	60'	
12'	1FC Avg ¹	52'	48'	62'	59'	
16'	1FC Avg ¹	52'	44'	61'	58'	
20'	1FC Avg ¹	44'	42'	60'	58'	
24'	1FC Avg ¹	34'	34'	42'	58'	

Maximum Spacing Guidelines — ELM6L ¹						
Mounting Height	Illumination Level	Single Luminaire		Multiple Luminaire		Application Notes
		3' Path of Egress	6' Path of Egress	3' Path of Egress	6' Path of Egress	
7.5'	1FC Avg ¹	76'	74'	98'	90'	100' Corridor, 8' wide, and 12' high with 80/50/20 reflectances
10'	1FC Avg ¹	76'	74'	98'	88'	
7.5'	1FC Avg ¹	60'	48'	77'	68'	Retail open area: 200' X 15' X 30' with 80/50/20 reflectances
10'	1FC Avg ¹	78'	56'	85'	82'	
12'	1FC Avg ¹	68'	66'	77'	74'	
16'	1FC Avg ¹	72'	68'	72'	74'	
20'	1FC Avg ¹	66'	64'	70'	68'	
24'	1FC Avg ¹	66'	56'	65'	62'	

Notes:

- Also meets the additional illumination requirements of NFPA 101: .1FC minimum and max/min ration of 40:1.

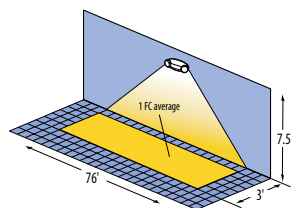

Example of single ELM6L illuminating a 3' path of egress

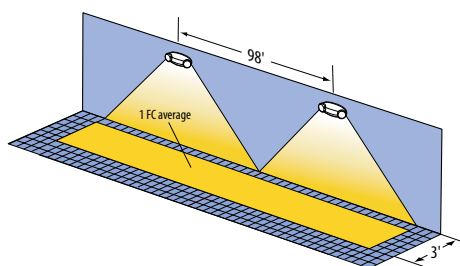

Example of multiple ELM6L units illuminating a 3' path of egress

ELM4L-ELM6L Quantum® LED Contemporary Commercial Emergency Light

REMOTES

BATTERY CAPACITY AND LOADING					
Battery Option (LTP Only)	Battery Voltage	Total Capacity 90 Minutes	LP220L (1.2 Watts each) Maximum # Remote Lamps ¹	SP640L (3.3 Watts each) Maximum # Remote Lamps ¹	SP1100L (5.3 Watts each) Maximum # Remote Lamps ^{1,2}
ELM4L LTP	9.6V	11 watts	3	1	0
ELM4L LTP HO	9.6V	22 watts	12	4	2
ELM4L LTP EHO	12.8V	32 watts	21	7	6
ELM6L LTP	9.6V	11 watts	0	0	0
ELM6L LTP HO	9.6V	22 watts	9	3	2
ELM6L LTP EHO	12.8V	32 watts	17	6	4
ELM6L LLH LTP	9.6V	11 watts	9	3	2
ELM6L LLH LTP HO	9.6V	22 watts	18	6	4
ELM6L LLH LTP EHO	12.8V	32 watts	26	9	6

Notes

- 1 These are in addition to the lamp heads on the product.
- 2 ELMRW not available with SP1100L lamp type. For SP1100L wet location applications, order ELMRE with WPVS.

ELMRE Compatible Remotes^{1,2}

LTP Compatible Remote Accessories: Order as separate catalog number.	
ELMRE LP220L SGL ^{1,2}	Single LED Indoor remote head, white.
ELMRE LP220L T ^{1,2}	Twin LED Indoor remote heads, white.
ELMRE SP640L SGL ^{1,2}	Single LED Indoor remote head, white.
ELMRE SP640L T ^{1,2}	Twin LED Indoor remote heads, white.
ELMRE SP1100L SGL ^{1,2}	Single LED Indoor remote head, white.
ELMRE SP1100L T ^{1,2}	Twin LED Indoor remote heads, white.
ELMRW LP220L DDBTXD SGL ^{1,3}	Single LED Wet Location remote head, dark bronze, 110 lumens
ELMRW LP220L DDBTXD T ^{1,3}	Twin LED Wet Location remote heads, dark bronze, 220 lumens
ELMRW SP640L DDBTXD SGL ^{1,3}	Single LED Wet Location remote head, dark bronze, 320 lumens
ELMRW SP640L DDBTXD T ^{1,3}	Twin LED Wet Location remote heads, dark bronze, 640 lumens

Notes

- 1 Compatible with SDRT and non-SDRT versions.
- 2 Order the WPVS accessory for wet location listing and vandal protection.
- 3 See ELMRW Specsheet for color options. Available in aluminum glossy, white glossy, black glossy, and dark bronze textured.



[ELMRE LP220L SGL](#)



[ELMRE LP220L T](#)



[ELMRE SP640L SGL](#)



[ELMRE SP640L T](#)



[ELMRE SP1100L SGL](#)



[ELMRE SP1100L T](#)



[ELMRW LP220L DDBTXD SGL](#)



[ELMRW LP220L DDBTXD T](#)



[ELMRW SP640L DDBTXD SGL](#)



[ELMRW SP640L DDBTXD T](#)



ELM4L_ELM6L

EMERGENCY: One Lithonia Way, Conyers, GA 30012 Phone: 1-800-705-SERV (7378) techsupport-emergency@acuitybrands.com www.lithonia.com

© 2018-2020 Acuity Brands Lighting, Inc. All rights reserved. Rev. 04/21/20 Pg. 4 of 5

ELM4L-ELM6L Quantum® LED Contemporary Commercial Emergency Light

SPECIFICATIONS

ELECTRICAL			
Primary Circuit			
Type	Volts	Input amps	Watts
Nicad	120	0.032	3.15
	347	0.036	3.15
Lithium Iron Phosphate (SDRT)	120	0.028	2.78
	347	0.033	2.78
Lithium Iron Phosphate (HO option)	120	0.046	4.77
	347	0.046	4.77
Lithium Iron Phosphate (EHO option)	120	0.052	5.95
	347	0.045	5.95

BATTERY CAPACITY FOR EXTENDED RUN-TIMES				
Battery Option	Total Capacity 2 hours	Remote Capacity 2 hours*	Total Capacity 4 hours	Remote Capacity 4 hours*
ELM4L - LTP	8.25 watts	NA	NA	NA
ELM4L - HO	16.5 watts	9.9 watts	8.25 watts	NA
ELM4L EHO	24 watts	17.4 watts	12 watts	5.4 watts
ELM6L - LTP	8.25 watts**	8.25 watts**	NA	NA
ELM6L HO	16.5 watts	5.9 watts	8.25 watts**	8.25 watts**
ELM6L EHO	24 watts	13.4 watts	12 watts	12 watts**

* Remote capacity left after using standard lamps shipped mounted on luminaire. ELM4L standard high performance LED lamp heads are rated at 3.3 watts each, delivering a total of 640 lumens. ELM6L standard high performance LED lamp heads are rated at 5.3 watts each, delivering a total of 1,100 lumens. These lamps are different in both wattage and performance from the LT24 compatible remotes.

** LLH option only

BATTERY			
Nicad (6V)			
Typical Shelf life ¹	Typical life ¹	Maintenance ²	Temperature range ^{3,4}
3 years	7-9 years	none	50-104°F (10-40°C)
Lithium Iron Phosphate (standard and HO option) (9.6V)			
Typical Shelf life ¹	Typical life ¹	Maintenance ²	Temperature range ^{3,4}
1 year	7-9 years	none	50-104°F (10-40°C)
Lithium Iron Phosphate (EHO option) (12.8V)			
Typical Shelf life ¹	Typical life ¹	Maintenance ²	Temperature range ^{3,4}
1 year	7-9 years	none	50-104°F (10-40°C)

Notes

- 1 At 77°F ambient temperature, charge/discharge cycles and prolonged full discharge may reduce useful life.
- 2 All life safety equipment, including emergency lighting for path of egress must be tested in accordance with all National Fire Protection Association (NFPA) and local codes. Failure to perform the required testing could jeopardize the safety of occupants and will void all warranties.
- 3 Optimum ambient temperature range where unit will provide capacity for 90 minutes. Higher and lower temperatures affect life and capacity.
- 4 Battery life is negatively impacted by many variables including temperature, charging rates, number of cycles and deep discharges due to long periods of time without AC power.



ELM4L_ELM6L

EMERGENCY: One Lithonia Way, Conyers, GA 30012 Phone: 1-800-705-SERV (7378) techsupport-emergency@acuitybrands.com www.lithonia.com

© 2018-2020 Acuity Brands Lighting, Inc. All rights reserved. Rev. 04/21/20

Pg. 5 of 5

WAC LIGHTING

5" Round Ceiling and Wall Mount

Fixture Type: _____

Catalog Number: _____

Project: _____

Location: _____

Model & Size	Color Temp & CRI	Watt	Lumens	Finish
FM-05RN 5"	930 3000K - 90	12W	1050	BZ Bronze
	935 3500K - 90	12W	1050	NI Nickel
				WT White

Example: **FM-05RN-930-BZ**

DESCRIPTION

Ultra-slim flush mount that uses edge-lit technology and a translucent diffuser for uniform illumination without shadows or hotspots.

FEATURES

- Multiple LED array for uniform illumination
- Suitable for outdoor and coastal regions
- Driver installed within the Junction Box, driver dimension: 2.25" Dia x 1" Deep
- 5 year warranty

SPECIFICATIONS

Construction:	Injection molded UV rated plastic with translucent diffuser for outdoor application
Power:	12W
Input:	120-277 VAC, 50/60Hz
Dimming:	TRIAC: 100-5%, ELV: 100-5%
Light Source:	Integrated LED
Lens:	Translucent acrylic diffuser
Mounting:	Installs over a 3", 4" or 3/0-4/0 hybrid junction box, Can be mounted on ceiling or wall in all orientations
Finish:	Enamel Coated White, Enamel Coated Nickel, Enamel Coated Bronze
Operating Temp:	-40°F to 122°F (-40°C to 50°C)
Standards:	ETL, cETL, Wet Location Listed, Energy Star 2.0, Title 24 JA8-2016 Compliant, ADA



FINISHES

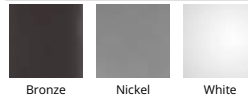

LINE DRAWING

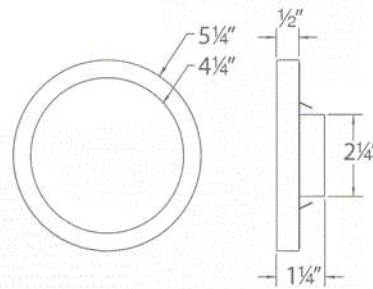

FM-05RN

wacighting.com | Phone (800) 526.2588 | Fax (800) 526.2585 | Headquarters/Eastern Distribution Center 44 Harbor Park Drive Port Washington, NY 11050

WAC Lighting retains the right to modify the design of our products at any time as part of the company's continuous improvement program. March 2020



WAC LIGHTING

7"/11"/15" Round Ceiling and Wall Mount

Fixture Type: _____

Catalog Number: _____

Project: _____

Location: _____

Model & Size	Color Temp & CRI	Watt	Lumens	Finish
FM-07RN 7"	930 3000K - 90	15W	1100	BN Brushed Nickel
	935 3500K - 90	15W	1100	BZ Bronze
FM-11RN 11"	930 3000K - 90	20W	1525	WT White
	935 3500K - 90	20W	1525	
FM-15RN 15"	930 3000K - 90	28W	2550	
	935 3500K - 90	28W	2550	

Example: **FM-07RN-930-BN**

DESCRIPTION

Ultra-slim flush mount that uses edge-lit technology and a translucent diffuser for uniform illumination without shadows or hotspots.

FEATURES

- Multiple LED array for uniform illumination
- Driver installed within the Junction Box, driver dimension: 2.25" Dia x 1" Deep
- 5 year warranty

SPECIFICATIONS

Construction:	Aluminum with translucent diffuser
Power:	20W, 15W, 28W
Input:	120 VAC, 50/60Hz
Dimming:	TRIAC: 100-5%, ELV: 100-5%
Light Source:	Integrated LED
Lens:	Translucent acrylic diffuser
Rated Life:	50000 Hours
Mounting:	Installs over a 3", 4" or 3/0-4/0 hybrid junction box, Can be mounted on ceiling or wall in all orientations
Finish:	Electrostatically Powder Coated White, Electroplated Brushed Nickel, Bronze
Operating Temp:	-4°F to 104°F (-20°C to 40°C)
Standards:	UL, cUL, Damp Location Listed, Energy Star 2.0, Title 24 JA8-2016 Compliant, ADA



FINISHES

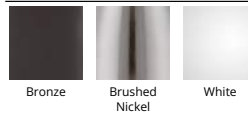

LINE DRAWING

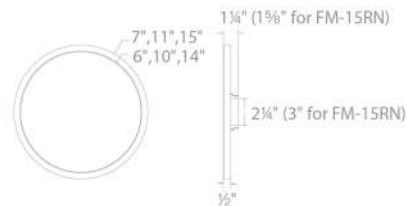

wacighting.com | Phone (800) 526.2588 | Fax (800) 526.2585 | Headquarters/Eastern Distribution Center 44 Harbor Park Drive Port Washington, NY 11050

WAC Lighting retains the right to modify the design of our products at any time as part of the company's continuous improvement program. March 2020



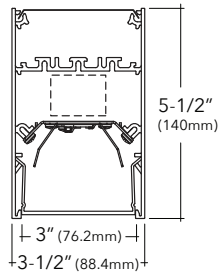
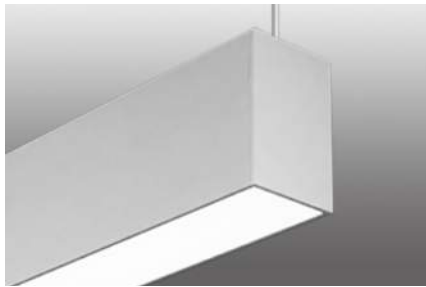

EDGE EX3D

3" Suspended Direct Linear

Key Features

- 6063-T6 Extruded aluminum housing
- Highly reflective die-formed white painted reflector
- Room side maintenance for LED system
- 5-year limited warranty covers LED, driver and fixture
- UL and cUL listed
- Approved for dry/damp location unless otherwise noted
- Maximum weight is 20 lbs. for a standard 4' fixture
- Buy American Act compliant
- Run lengths available to an 1/8"



QUICKSHIP



Example Part #: EX3D-HE-N-830HO-26'-AC48G1-U-OL1-1-0-W

EX3D - DIRECT SHIELDING - INDIRECT SHIELDING - SOURCE - LENGTH OR PATTERN - MOUNTING - VOLTAGE - DRIVER - CIRCUITING - BATTERY & EMERGENCY - FINISH - FIXTURE OPTIONS - CONTROLS

---	N	-----	---
DIRECT SHIELDING	INDIRECT SHIELDING	SOURCE ^{QS, 1}	LENGTH OR PATTERN ²
A - Satine Lens ^{QS} AL - Drop Lens HE - High Efficiency ^{QS} BW - Batwing ^{QS} WHE - Asymmetric ^{QS} HED - Descent <i>Shielding pg. 2</i>	N - None <i>Shielding pg. 2</i>	_27_ - 2700K _30_ - 3000K _35_ - 3500K (available with BIOS) _40_ - 4000K (available with BIOS) CL - Custom Lumens CW - Custom Watts <i>Lumen Output pg. 2</i>	_ - Individual Fixture ^{QS} _ - Continuous Row ^{QS} S - Square ^{QS} R_x_ - Rectangle ^{QS} L_x_ - L Shape ^{QS} U_x_ - U-Shape ^{QS} T_x_ - T-Shape X_x_x_ - X-Shape M - Mod Layout <i>Length and Pattern pg. 2-3</i>
-----	-	---	-
MOUNTING ³	VOLTAGE	DRIVER	CIRCUITING
_AC_G_ - (M)AC to Grid ^{QS} _AC_JB_ - (M)AC to J Box ^{QS} _AC_ST_ - (M)AC to Structure ^{QS} _AC5_G_ - 5" Non-Power Canopy _AC5_JB_ - 5" Non-Power Canopy _SQ_G_ - 5" Square Canopy _SQ_JB_ - 5" Square Canopy WA - Wall Mount ^{QS} S - Surface Mount ^{QS} <i>Mounting pg. 3</i>	U - Universal (120 thru 277V) ^{QS} 1 - 120V ^{QS} 2 - 277V ^{QS} 3 - 347V <i>Voltage pg. 4</i>	OL1 - Osram (10%, 0-10v, standard) ^{QS} OL2 - Osram (1%, 0-10v) OL3 - Osram 347v (10%, 0-10v) EE1 - eldoLED ECOdrive (1%, 0-10v) ES1 - eldoLED SOLOdrive (0%, 0-10v) LH1 - Lutron Hi-lume (1%, EcoSystem) ^{QS} L51 - Lutron 5-Series (5%, EcoSystem) PL2 - Philips Xitanium (1%, 0-10v) PS1 - Philips Xitanium (50%/100%) ND - Non-Dimming ^{QS} <i>Driver pg. 4</i>	1 - Single Circuit ^{QS} M - Multi Circuit E - Emergency (entire fixture) ^{QS} N - Night Light (entire fixture) ^{QS} <i>Circuiting pg. 4</i>
---	---	-----	---
BATTERY & EMERGENCY ⁴	FINISH	FIXTURE OPTIONS ⁵	CONTROLS ⁶
0 - None ^{QS} _PL - Philips Bodine 10W _IL - Iota 10W Integral ^{QS} _E - Emergency Section _N - Night Light Section _L - Life Safety Section _G - Philips Bodine GTD <i>Battery and Emergency pg. 4</i>	W - White ^{QS} S - Metallic Silver ^{QS} BL - Textured Black BR - Bronze GR - Graphite CC - Custom Color <i>Finish pg. 5</i>	QS - Quick Ship ^{QS} LMRA - Adjustable MR16 (LED) XLED - Fixed Xicato LED <i>Fixture Options pg. 5-6</i>	NLTAIR - Acuity nLight AIR (wireless) EASYS - Philips EasySense (wireless) SNSLM - Osram Senilum (wireless) WVLX - Eaton WaveLinX (wireless) VDO - Lutron Vive Sensor (wireless) VRF - Lutron Vive Connected (wireless) <i>Controls pg. 6</i>

¹When specifying SOURCE the first _ is for specifying either **B** - 80CRI, **9** - 90CRI or **B** - BIOS. The ending _ are for specifying output, example **HO** - High Output. When specifying BIOS use **B** and then specify color temperature, either 3500K or 4000K, and output, example **B35HO** - BIOS 3500K High Output. See output charts for more information. For Quickship CRI, CCT & Output see chart on page 5. ²Individual fixtures come in 2', 3', 4', 5', 6', 7' & 8' lengths. Continuous row come in 1/8" increments. For Mod layouts specify pattern shape and overall dimensions. Example: L6x4: L pattern that is 6'x4'. ³Specify AC Cable: Standard single AC = AC or Movable AC = MAC; Specify AC length standard AC is 48"; Specify grid: G1=15/16", G9=9/16", G5=Screw Slot. Example: AC48G1 ⁴Enter quantity for Battery and Emergency, Example 2P. ⁵QS must be used in fixture options section of part number to qualify. 1/8" increments not available for QS. ⁶Controls can only be used with Single Circuit (1) or Emergency Circuit (E). See Controls chart on page 5 for driver options and more information.

Specifications and dimensions subject to change without notice. Specification sheets that appear on pinnacle-ltg.com are the most recent version and supersede all other previously printed or electronic versions.



Direct Shielding

Indirect Shielding

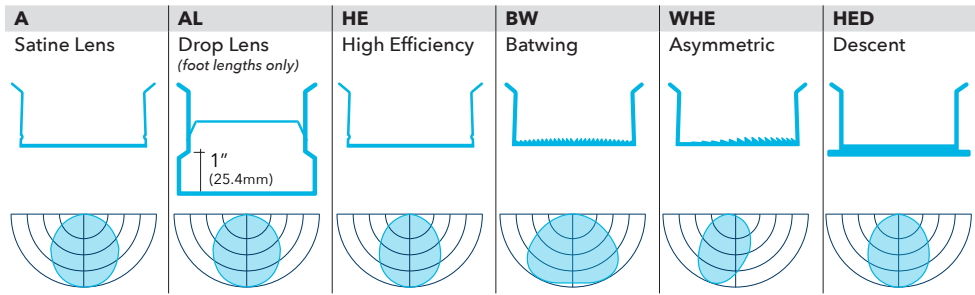

Source: White LED¹

- Specify either 80 or 90 CRI
- Longer lead-time may apply for 90 CRI. Consult factory.
- 80 CRI = R9≥19 and 90 CRI = R9≥61
- Not all products qualify for DLC listing. For a complete listing of the EV3D products that qualify for DLC, please go to the DLC website.

Custom Output - Lumens OR Wattage

CL _____	Specify CRI, CCT and desired lumens (i.e. CL835500)	Specify lumens between standard offering listed below. Lumens are specified per color temp
CW _____	Specify CRI, CCT and desired wattage (i.e. CW9407)	Specify watts between standard offering listed below

80 CRI

	Color	Lumens per foot	Shielding ¹													
			A Satine		AL Drop		HE High Efficiency		BW Batwing		WHE Asymmetric		HED Descent			
			LPW	Watts/ft	LPW	Watts/ft	LPW	Watts/ft	LPW	Watts/ft	LPW	Watts/ft	LPW	Watts/ft		
830	3000K	500	97	5.2	120	4.2	107	4.7	102	4.9	99	5.1	95	5.2		
830HO	3000K	750	97	7.8	121	6.2	108	6.9	103	7.3	100	7.5	95	7.9		
830VHO	3000K	1000	84	11.8	121	8.2	111	9.0	104	9.6	102	9.8	97	10.3		
835	3500K	500	99	5.0	124	4.0	110	4.5	105	4.8	102	4.9	97	5.1		
835HO	3500K	750	100	7.5	125	6.0	111	6.8	105	7.1	103	7.3	98	7.7		
835VHO	3500K	1000	87	11.5	125	8.0	111	9.0	108	9.3	104	9.6	100	10.0		
840	4000K	500	99	5.0	124	4.0	110	4.5	105	4.8	102	4.9	97	5.1		
840HO	4000K	750	100	7.5	125	6.0	111	6.8	105	7.1	103	7.3	98	7.7		
840VHO	4000K	1000	88	11.4	125	8.0	111	9.0	108	9.3	104	9.6	100	10.0		

90 CRI

927	2700K	500	79	6.3	100	5.0	88	5.7	84	6.0	81	6.2	78	6.4
927HO	2700K	750	82	9.2	100	7.5	89	8.5	84	9.0	84	8.9	80	9.4
930	3000K	500	85	5.9	108	4.6	97	5.2	90	5.6	87	5.7	84	5.9
930HO	3000K	750	86	8.7	109	6.9	96	7.8	91	8.2	88	8.5	85	8.9
935	3500K	500	85	5.9	107	4.7	96	5.2	90	5.6	87	5.7	84	5.9
935HO	3500K	750	86	8.7	108	6.9	96	7.8	91	8.3	88	8.5	84	8.9
940	4000K	500	85	5.9	107	4.7	96	5.2	90	5.6	87	5.7	84	5.9
940HO	4000K	750	86	8.7	108	6.9	96	7.8	91	8.3	88	8.5	84	8.9

Source: BIOS¹

- CRI >84, R9 >90
- Spectrum focused lighting for circadian stimulus
- High EML or M/P ratio: .8 for 3500K, .9 for 4000K
- COI: ≤3.3
- Available for use with most Driver or Control options

Custom Output - Lumens OR Wattage

CLB _____	Specify CRI, CCT and desired lumens (i.e. CL835500)	Specify lumens between standard offering listed below. Lumens are specified per color temp
CWB _____	Specify CRI, CCT and desired wattage (i.e. CW9407)	Specify watts between standard offering listed below

BIOS

	Color	Lumens per foot	Shielding ¹							
			A Satine		HE High Efficiency		BW Batwing			
			LPW	Watts/ft	LPW	Watts/ft	LPW	Watts/ft		
B35	3500K	500	57	8.7	67	7.4	61	8.2		
B35HO	3500K	750	N/A	N/A	66	11.4	60	12.5		
B40	4000K	500	59	8.6	69	7.2	62	8.0		
B40HO	4000K	750	N/A	N/A	68	11.1	61	12.3		

¹LPW and watts/ft based off 48" fixture size.

Specifications and dimensions subject to change without notice. Specification sheets that appear on pinnacle-ltg.com are the most recent version and supersede all other previously printed or electronic versions.

Designed in Denver, CO • USA | pinnacle-ltg.com | O: 303-322-5570 F: 303-322-5568

EX3D_LED_SPEC_JAN2020



Length

- Individual units cannot be joined, end plates are factory installed and cannot be removed
- For Continuous Runs, add 3/16" (4.7mm) for each end plate or 3/8" (9.5mm) to the overall length of the row
- For patterns, refer to Pattern section on next page

2	3	4	5	6	7	8	-
Indiv. Fixture	Indiv. Fixture	Indiv. Fixture	Indiv. Fixture	Indiv. Fixture	Indiv. Fixture	Indiv. Fixture	Cont. Run Specify nominal overall row length to the 1/8" Longer lead-time may apply for lengths to the 1/8". Consult factory.
24-3/8" (619.1mm)	36-3/8" (934.8mm)	48-3/8" (1228.7mm)	60-3/8" (1533.5mm)	72-3/8" (1838.3mm)	84-3/8" (2143.1mm)	96-3/8" (2447.9mm)	
							Specify to the 1/8" >>>

Pattern

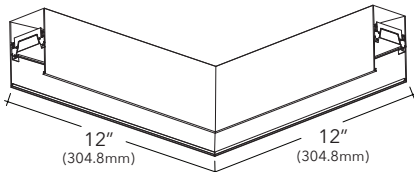

- Specify pattern shape and overall dimensions (includes corner dimensions)
- Refer to dimensions table below for available standard lengths
- All connectors are direct only
- 90 degree horizontal corners are 12"x12" (overall, outside dimension)
- Angles and shapes not shown require Mod Pattern; consult factory
- Only available with "A" or "HE" lens options

S_	R_x_	U_x_x_	L_x_	T_x_	X_x_	M
Square Provide A dimension Example: S4' Minimum Length- 4'x4'	Rectangle Provide AxB dimensions Example: R4'x4' Minimum Length- 4'x4'	U-Shape Provide AxBxC dimensions Example: U3'x4'x3' Minimum Length- 3'x4'x3'	L-Shape Provide AxB dimensions Example: L3'x3' Minimum Length- 3'x3'	T-Shape Provide AxB dimensions Example: T3'x5' Minimum Length- 3'x5'	X-Shape Provide AxB dimensions Example: X5'x5' Minimum Length- 5'x5'	Mod Layout For patterns or lengths not shown or standard

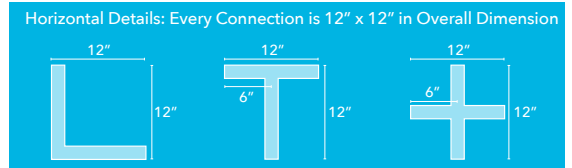
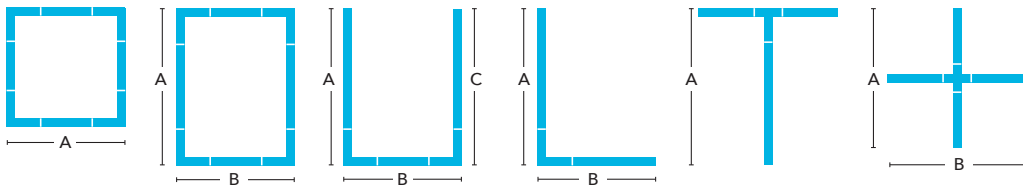

Specifications and dimensions subject to change without notice. Specification sheets that appear on pinnacle-ltg.com are the most recent version and supersede all other previously printed or electronic versions.
 Designed in Denver, CO • USA | pinnacle-ltg.com | O: 303-322-5570 F: 303-322-5568
 EX3D_LED_SPEC_JAN2020



Mounting

- Specify cable length in ordering code (AC48G1)
- Standard adjustable cable, specify 48", 120", 240", or 350"
- End plates and power cord attached at factory
- Aircraft cable (AC) mounts on 4' (1219.2mm) and 8' (2438.4mm) centers
- Maximum recommended movable mounting locations are 12" from end of 4' fixture and 18" from end of 8' fixture
- Aircraft Cable supplied with 5" (127mm) power and 2" (50.8mm)

- non-power canopies
- Canopies and pendants match fixture finish, power cords are white, grey, or black depending on fixture finish. See Finish section for additional details.
- Approved for dry/damp location unless otherwise noted
- Refer to installation instructions during installation at the job site
- Maximum fixture weight is 20 lbs for a standard 4' fixture

AC_G1	Aircraft Cable 1" (15/16") T-Bar
AC_G9	Aircraft Cable 9/16" T-Bar
AC_GS	Aircraft Cable Screw Slot T-Bar
AC_JB	Aircraft Cable Junction Box
AC_ST	Aircraft Cable Structure
AC5_G	Aircraft Cable 5" (127mm) Non-Power Canopy
AC5_JB	Aircraft Cable 5" (127mm) Non-Power Canopy
SQ_G	Aircraft Cable 5" (127mm) Square Canopy
SQ_JB	Aircraft Cable 5" (127mm) Square Canopy
MAC_G1	Moveable AC 1" (15/16") T-Bar
MAC_G9	Moveable AC 9/16" T-Bar
MAC_GS	Moveable AC Screw Slot T-Bar
MAC_JB	Moveable AC Junction Box
MAC_ST	Moveable AC Structure
MAC5_G	Moveable AC 5" (127mm) Non-Power Canopy
MAC5_JB	Moveable AC 5" (127mm) Non-Power Canopy
MSQ_G	Moveable AC 5" (127mm) Square Canopy
MSQ_JB	Moveable AC 5" (127mm) Square Canopy
WA	Wall Mount
S	Surface Mount

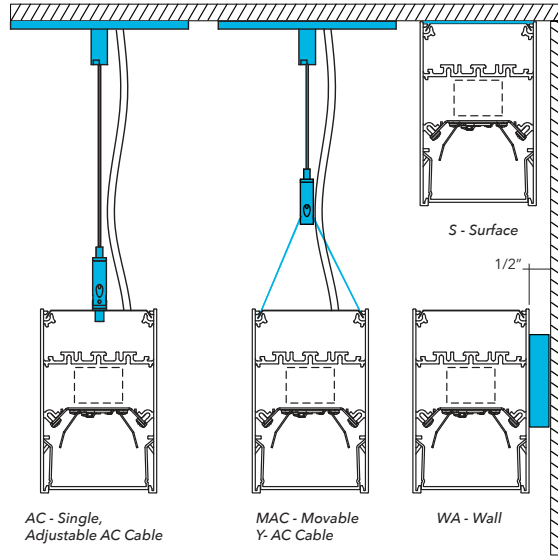

Straight EDGE Joint System

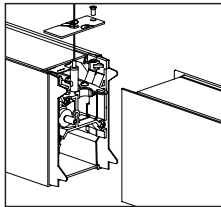

- The Straight EDGE Joint comes standard for all runs.
- Two connection points - one to cinch fixtures together, the other to perfectly align all fixtures in a run.
- Factory-installed light shields on both sides of the fixture ensure no light leaks.
- Patented.

Voltage

- Some EX3D configurations will not accommodate all voltage options; consult with factory

U	Universal
1	120 volt
2	277 volt
3	347 volt

Driver

- Standard Driver Option = OL1
- Driver Lifetime: 50,000 hours at 25°C ambient operating conditions
- For more driver options see Pinnacle Resource Guide
- Some EX3D configurations will not accommodate all driver options; consult with factory

OL1	Osram Optotronic 10%, 0-10v
OL2	Osram Optotronic 1%, 0-10v, nominal 1% dimming range
OL5	Osram Optotronic 1%, 0-10v, AUX
OD1	Osram Optotronic 1%, DEXAL
EE1	eldoLED ECOdrive 1%, 0-10v Logarithmic
EE6	eldoLED ECOdrive 1%, for nLight Air Wireless
ES1	eldoLED SOLOdrive 0%, 0-10v Logarithmic
ES6	eldoLED SOLOdrive 0%, for nLight Air Wireless
LH1	Lutron Hi-lume Soft-on, Fade-to-black 1%, EcoSystem, LDE1
L51	Lutron 5-Series 5%, EcoSystem, LDE5
PL2	Philips Advance Xitanium 1%, 0-10v
PR1	Philips Advance Xitanium SR, requires EASY, VDO, or VRF
ND	Non-Dimming

Specifications and dimensions subject to change without notice. Specification sheets that appear on pinnacle-ltg.com are the most recent version and supersede all other previously printed or electronic versions.

Designed in Denver, CO • USA | pinnacle-ltg.com | O: 303-322-5570 F: 303-322-5568

EX3D_LED_SPEC_JAN2020

pg. 4



How to specify Circuiting, Battery and Emergency

- 1** • Select fixture circuiting from options below
 • Some EX3D configurations will not accommodate all circuiting options, consult with factory

Circuiting

1	Single Circuit
M	Multi Circuit
E	Emergency Circuit only
N	Night Light Circuit only

- 2** + **3** • Battery and emergency section options are available in addition to fixture circuit
 • Select battery and emergency section options below; factory shop drawing required
 • Some EX3D configurations will not accommodate all circuiting options, consult with factory

Battery and/or Emergency If Required

- 0** No battery or specific emergency section required

Battery

- Select battery section type if required, indicate total QTY. *Example 2PL*
- 90 minute battery runtime; test button is remote to fixture and requires an additional drop
- No battery option available for 2' lengths
- Entire direct fixture housing is on battery for lengths up to 5'
- Half of direct fixture is on battery for 6' or 8' housing lengths
- For more battery options available, see Pinnacle Resource Guide

0	No battery
_PL	Philips Bodine 10w Integral
_IL	Iota 10w Integral

For Approximate Battery Lumen Output

- Multiply battery wattage X fixture LPW shown on Lumen Table
- $92.3 \text{ (LPW)} \times 10 \text{ (watts)} = 923 \text{ battery lumen output}$

Emergency

- Select emergency section type if required, indicate total QTY. *Example 1E*
- Combine battery and emergency section ordering codes if both options are selected

_E	Emergency circuit section
_N	Night Light circuit section
_L	Life Safety circuit section NO THROUGH WIRE
_G	Philips Bodine GTD, Generator Transfer Device section

Battery OR Emergency Ordering Examples

- Single circuit, 10w Integral Battery Ordering Code: 1-1PL
- Emergency only, 10w Integral Battery Ordering Code: E-1PL
- Single circuit, GTD required Ordering Code: 1-1G

Combination Section Ordering Examples

- Single circuit, (1) 10w battery, (1) emergency section Ordering Code: 1-1PL1E
- Multi circuit, (2) 10w battery, (2) emergency sections Ordering Code: M-2PL2E
- Single circuit, (1) night light section Ordering Code: 1-1N

Finish

- Standard powder-coat textured white, metallic silver, textured black, graphite or bronze painted finish; consult factory for chip of standard paint finishes
- Selecting a fixture finish other than white may impact lumen output; consult factory for more information

W	White (<i>white cord/white canopy</i>)
S	Metallic Silver (<i>grey cord/silver canopy</i>)
BL	Textured Black (<i>black cord/black canopy</i>)
BR	Bronze (<i>white cord/bronze canopy</i>)
GR	Graphite (<i>white cord/graphite canopy</i>)
CC	Custom Color (<i>white cord/color match canopy</i>)

Fixture Options

- Additional options to enhance the fixture and finish of the product
- Consult factory for MR16 configurations

QS	10 day Quick Ship
LMRA	Adjustable MR16 LED (<i>not available with U voltage</i>)
XLED	Fixed Xicato LED

Specifications and dimensions subject to change without notice. Specification sheets that appear on pinnacle-ltg.com are the most recent version and supersede all other previously printed or electronic versions.

Designed in Denver, CO • USA | pinnacle-ltg.com | O: 303-322-5570 F: 303-322-5568

EX3D_LED_SPEC_JAN2020

pg. 5



Quick Ship

Shielding	CRI, CCT & Output	Mounting	Voltage	Driver	Circuiting	Battery	Finish	
10-Day								
A HE BW WHE	80 CRI, all color temperatures, all lumen packages <i>See pg 2</i>	(M)AC48G_ (M)AC48JB (M)AC48ST W S	(M)AC to Grid (M)AC to J-BOX (M)AC to Structure Wall Mount Surface Mount	U Universal (120-277) 1 120V 2 277V	OL1 Osram 0-10v, 10% LH1 Lutron LDE1 ND Non-Dimming	1 Single Circuit E Emergency N Night Light	0 None I Iota 10w Integral	W White S Silver

All lengths and continuous rows up to 1,000 ft OR 150 individual fixtures. Consult factory for larger projects.

Controls

- Pinnacle Lighting offers easy to specify network control solutions that connect to an intelligent centralized system to maximize lighting energy efficiencies or integral sensors for individual fixture control
- Pinnacle Lighting fixtures ship technology ready; commissioning by others
- Controls can only be used with Single Circuit (1) or Emergency Circuit (E)
- Contact factory for any non-standard configurations for layout, placement, or EM options
- One drop/sensor per run typical, contact factory for more information
- Must specify required driver in Driver Section

	Solution	Components	Network/Sensor	Connection	Required Drivers	Limitations
NLTAIRS	Acuity nLight AIR Wireless	RES7 G2	nLight, Daylight/PIR Occupancy Sensor	Wireless	EE6, ES6	Not available with 347 volt
NLTAIRM	Acuity nLight AIR Wireless	RES7 PDT G2	nLight, Daylight/PIR Occupancy Sensor	Wireless	EE6, ES6	Not available with 347 volt
NLTAIR	Acuity nLight AIR Wireless Connected	RIO EZDL G2	nLight	Wireless	EE6, ES6	Not available with 347 volt
EASYS	Philips EasySense	SNS-200	Daylight/PIR Occupancy	Wireless to switches	PR1	Not available with 347 volt
SNSLM	Osram Sensilum	EN-CLM-PIR-DD-ZB	Encelium, Daylight/PIR Occupancy	Wireless	OD1, OL1, OL2	Not available with 347 volt
WLX	Eaton WaveLinx	SWPD1, MSP3IVMVDC1	WaveLinx WCL, Daylight	Wireless	Any 0-10v	Not available with 347 volt
VDO	Lutron Vive Sensor	DFCSJ-OEM-OCC	Vive, Daylight/PIR Occupancy	Wireless	OD1, PR1	Not available with 347 volt
VRF	Lutron Vive Connected	DFCSJ-OEM-RF	Vive	Wireless	OD1, PR1	Not available with 347 volt

Photometrics

Satine Lens

Test # ITL89801
 Catalog # EX3D-HE-840-4
 Lumens 1978 lm
 Watts 19.3 W
 Efficacy 102.5 LPW

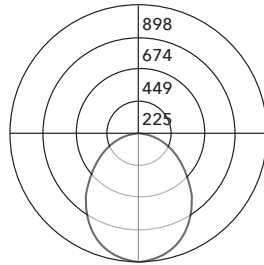

Candela Distribution

Vert Angle	Horizontal Angle				
	0	22.5	45	67.5	90
0	898	898	898	898	898
5	892	892	891	889	888
10	876	872	869	863	861
15	851	840	832	822	815
20	813	797	783	765	756
25	764	744	724	698	687
30	707	685	657	626	613
35	643	620	587	551	537
40	579	553	517	479	463
45	508	483	445	409	394
50	437	414	377	344	330
55	367	347	313	283	272
60	300	283	253	228	218
65	236	222	197	178	169
70	174	165	145	130	126
75	117	110	97	87	85
80	68	64	56	51	50
85	28	27	23	21	22
90	0	0	0	0	0

Luminance Data (cd/sq.m)

Angle In Degrees	Average 0-Deg	Average 45-Deg	Average 90-Deg
45	7804	6836	6053
55	6951	5928	5151
65	6066	5064	4344
75	4911	4071	3568
85	3490	2867	2742

For all available IES files, please visit our website at pinnacle-ltg.com. Photometry testing in accordance to IESNA-LM-79-08 at an NVLAP accredited testing laboratory. Testing conducted at 25°C ambient conditions

Specifications and dimensions subject to change without notice. Specification sheets that appear on pinnacle-ltg.com are the most recent version and supersede all other previously printed or electronic versions.

Designed in Denver, CO • USA | pinnacle-ltg.com | O: 303-322-5570 F: 303-322-5568

EX3D_LED_SPEC_JAN2020



Applications & Certificates

Construction: 6063-T6 Extruded aluminum housing. Highly reflective steel white painted reflector.

Shielding: Diffuse snap-in acrylic lens, removable for maintenance.

Mounting: Aircraft cable and wall mount available. Select from 2 aircraft cable options. Select the straight aircraft cable that mounts on 4'-0" (1219.2mm) and 8'-0" (2438.4mm) centers or the moveable adjustable Y-cable mount. The Y-Cable design allows for adjustable mounting locations. Aircraft Cable supplied with 5" (127mm) power and 2" (50.8mm) non-power canopies. Refer to installation instructions for appropriate ceiling detail. Canopies are painted white unless otherwise specified. Maximum fixture weight is 20 lbs. for a standard 4' fixture.

LED: 25°C test environment. Lumen output/wattage has a margin of +/- 5%; 2' or 3' lengths may have a greater wattage deviation. All luminaire configurations tested in accordance with IES LM-79. Diodes tested in accordance with IES LM-80. Lifetime calculated using IES TM-21. Minimum lifetime greater than 60,000 hours. L70 = 136,200 hours and L90 = 41,100 hours. MacAdam 3-Step Ellipses. For all available IES files, please visit our website at pinnacle-ltg.com.

BIOS LED: Spectrum focused lighting for circadian stimulus. EML or M/P ratio: .8 for 3500K, .9 for 4000K. COI >3.0. Not all lumen packages available. Two lumen packages available. Standard, and High (HO). Custom outputs are available. Specify custom lumens or watts between standard offering listed on CRI, CCT & Output page.

CRI, CCT & Output: Two lumen packages available. Standard and High (HO). Custom outputs are available. Specify custom lumens or watts between standard offering listed on CRI, CCT & Output page. 80 CRI is available for 3000K, 3500K, and 4000K. 90 CRI is available for 2700K, 3000K, 3500K, and 4000K. 80 CRI = R9≥19 and 90 CRI = R9≥61.

Voltage: Universal (U), 120 volt (1), 277 volt (2) and 347 volt (3) options available. Must specify OL3 in Driver section when 347 volt (3) is selected. Some EX configurations will not accommodate all voltage options; consult with factory.

Driver: Standard Driver Option is Osram 0-10V, 10% = OL1. Electronic driver, Power factor is >0.9 with a THD <20%. Driver Lifetime: 50,000 hours at 25°C ambient operating conditions. Ambient operating range: -20°F/-30°C to 120°F/49°C. For more driver options, see Pinnacle Resource Guide. Some EX configurations will not accommodate all driver options.

Circuiting: Select from single circuit (1), Multi circuit (M), Emergency circuit (E) or Night Light circuit (N). For emergency circuiting situations that require no through wire or circuit separation, Life Safety Circuit should be selected. This will provide a separate power feed and only the Life Safety Circuit in that section. Some EX configurations will

not accommodate all circuiting options, consult with factory.

Battery & Emergency: Select battery or emergency options if required. If battery or emergency option is not required, enter 0. Battery duration is 90 minutes as standard. Test button is remote to fixture. For more Battery options, see Pinnacle Resource Guide.

Finish: Standard powder-coat textured white, metallic silver, textured black, graphite or bronze painted finish; consult factory for chip of standard paint finishes. Canopies painted white unless specified differently in the options section of the part number. Contact factory for additional custom color and finish options.

MR16: Ideal for conference rooms, corridors, wall washing, retail spaces and training facilities where accent lighting is required. Fully enclosed compartment eliminates light from entering into our fixture areas. For LED and Halogen lamps (lamps are not included). Consult factory for other lamp types. Standard 60 watt max LED electronic transformer (120v or 277v), 50 watt max halogen lamp electronic transformer (120v or 277v), MR16 installed as an independent circuit. MR16 to match fixture voltage. 277v dimmer must be sourced. Consult factory for MR16 configurations. Pinnacle's MR16 applications are to be used with Soraa lamps with a maximum of 13 transformers on one circuit.

Controls: nLight Air rES7 sensor provides wireless control, daylight harvesting and occupancy detection with PIR or PDT using eldoLED LED drivers. nLight Air rIO module provides wireless control using eldoLED LED drivers. EasySense sensor provides daylight harvesting and PIR occupancy detection using the SR LED driver; the Philips app provides advanced configurations. ENCELIUM SensiLUM sensor provides wireless control, daylight harvesting and PIR occupancy; driver data is available when using the DEXAL driver. ENCELIUM SensiLUM sensor provides wireless control, daylight harvesting and PIR occupancy; driver data is available when using the DEXAL driver. WaveLinX Connected Lighting sensor provides wireless control and daylight harvesting using 0-10V LED drivers. Lutron Vive sensor provides wireless control, daylight harvesting and PIR occupancy detection using DEXAL or SR LED drivers. Lutron Vive module provides wireless control using DEXAL or SR LED drivers.

Labels: UL and cUL Listed. Standard and HO lumen packages are approved for dry/damp location unless otherwise noted.

Fixture Weight: Maximum fixture weight is 20 lbs. for a standard 4' fixture.

Buy American Act Compliant

Warranty: EX LED offered with a 5-year limited warranty. Covers LED, driver and fixture.

Specifications and dimensions subject to change without notice. Specification sheets that appear on pinnacle-ltg.com are the most recent version and supersede all other previously printed or electronic versions.

Designed in Denver, CO • USA | pinnacle-ltg.com | O: 303-322-5570 F: 303-322-5568

EX3D_LED_SPEC_JAN2020

pg. 7

Project		Catalog #		Type	
Prepared by		Notes		Date	

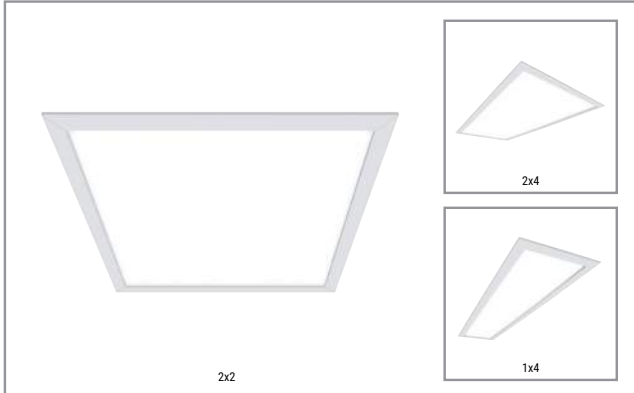

Metalux

CGT LED

LED Panel

Typical Applications

Offices • Education • Healthcare • Retail

Interactive Menu

- Order Information [page 2](#)
- Photometric Data [page 3](#)
- Product Warranty

Product Certification



Top Product Features

- Robust die-formed steel housing is post-painted for maximum durability
- Acrylic micro optics provide uniform illumination from corner to corner
- Extruded aluminum bezel with mitered corners tightly sealed to the housing to optimize durability and aesthetics
- Thin 2.125" height fits shallow plenums with room to spare
- Projected lumen maintenance based on TM21 testing standards is >L84, @60,000 hours

Dimensional and Mounting Details

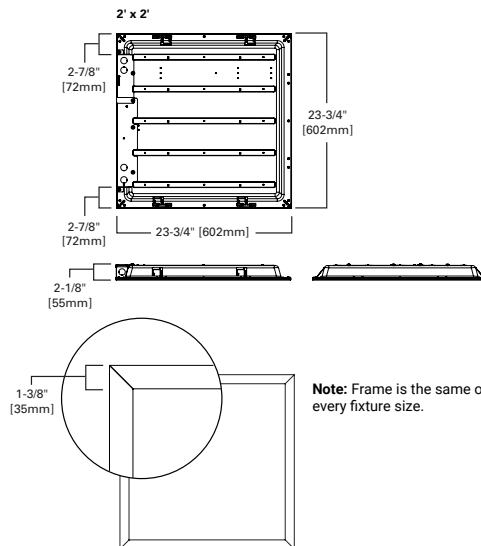
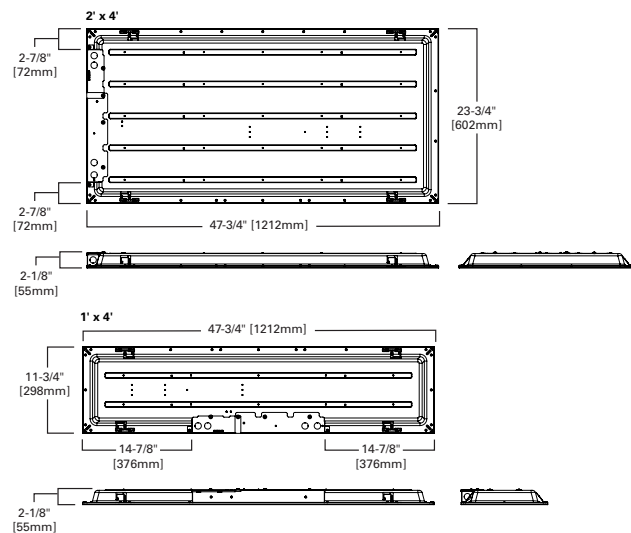

Note: Frame is the same on every fixture size.

Ordering Information/Performance

Standard Options

Catalog	Size	UPC	CCT	CRI (Min)	Delivered Nominal Lumens	Watts		Efficacy (lm/W)		Input Current (A)	
						120V	277V	120V	277V	120V	277V
14CGT4035C	1x4	080083879526	3500K	80	4189	39.4	38.8	106	108	0.33	0.15
14CGT4040C		080083879540	4000K	80	4351			110	112		
14CGT4050C		080083879861	5000K	80	4351			110	112		
22CGT3535C	2x2	080083880003	3500K	80	3449	31.4	31.7	110	109	0.2	0.09
22CGT3540C		080083880027	4000K	80	3582			114	113		
22CGT3550C		080083880041	5000K	80	3582			114	113		
24CGT4535C	2x4	080083880089	3500K	80	4268	38.8	38	110	112	0.33	0.15
24CGT4540C		080083880102	4000K	80	4432			114	117		
24CGT4550C		080083880126	5000K	80	4432			114	117		
24CGT5535C	2x4	080083880164	3500K	80	5139	46.8	46.4	110	111	0.39	0.18
24CGT5540C		080083880188	4000K	80	5337			114	115		
24CGT5550C		080083880201	5000K	80	5337			114	115		

Options/Ordering Information

EL14W=EBPLED14W battery installed ⁽²⁾
 EL7W=EBPLED7W battery installed ⁽²⁾
 Example catalog number=24CGT4540C-EL14W ⁽¹⁾

A3/8-5D/18G=6' 3/8" flex with dimming leads installed
 Example catalog number=24CGT4540C-A3/8-5D/18G ⁽¹⁾

Notes : (1) Catalog number used as an example, substitute the desired catalog number required. (2) Indicator/test switch to be installed separately. For approximate delivered lumens multiply the lumens per watt of the desired fixture by the wattage of the emergency battery pack (100 lm/W x 7=700 lumens).

Shipping Data

	1x4	2x2	2x4
Product Weight (lb.)	7.3	6.8	11.9
Packaged Weight (lb.)	8.4	8.4	14.5
Pallet Qty	54	72	36
Pallet Size	52x40	52x49	

Load Data

THD	<15% THD
PF	>.94 PF

Accessories/Ordering Information

(CGT specific accessories available to ship in March 2020)

Catalog No.	Description	UPC
CGTEQ	EQ Clip Kit for CGT Troffer	080083083084
CGTSURF24	2x4 CGT Surface Mount Kit	080083083107
CGTSURF22	2x2 CGT Surface Mount Kit	080083083121
CGTSURF14	1x4 CGT Surface Mount Kit	080083083145

Emergency Battery

Catalog No.	Description	UPC	Watts
EBPLED7W	7 Watt emergency battery field installed	080083732265	7
EBPLED14W	14 Watt emergency battery field installed	080083732272	14

Suspension Kit

Catalog	UPC
FPSUS2	080083802784

Mounting height from ceiling
 Min.=7-1/4" [184mm]
 Max.=27" [286mm]

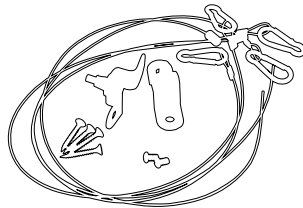

Drywall Frame Kit

Catalog No.	Description	UPC	Size
DF-24W-U	2x4 dry wall frame kit	662401232970	2x4
DF-22W-U	2x2 dry wall frame kit	662401232963	2x2
DF-14W-U	1x4 dry wall frame kit	662401232949	1x4

Product Specifications

Construction

- Robust die-formed steel back plate is post-painted to ensure durability
- Housing is constructed with limited holes which are covered to resist debris/bug intrusion
- Aluminum bezel with mitered corners is tightly fastened to the housing

Mounting

- Integral grid clips provided and include suspension / wire retention features
- Grid clip includes fold up hang points. Use FPSUS2 or other desired suspension methods for direct suspension
- "Earthquake clip" accessories are available for use where required
- Junction box constructed of code gauge galvanized steel with access plate
- Multiple Trade size KO provided and JBox is suitable for up to 12AWG wiring
- Surface and suspension kits are available to for use in grid or on hard surfaces
- Factory installed flexible cable with dimming leads options available

Controls

- Standard UNV 120 - 277V driver with 0-10V dimming to 10% standard
- Can be used with tile mounted sensor or other remotely mounted controls

Electrical

- Projected lumen maintenance based on TM21 testing standards is >L84 @60,000 hours
- Driver is rated for FCC part 15 Class B for use in residential or commercial applications
- LEDs are 80 CRI (minimum) and available in 3500K, 4000K, and 5000K CCT
- Emergency battery pack options available in 7W and 14W options

Optical Shielding

- Acrylic micro-optics enable uniform distribution of the LEDs to eliminate hot spots
- White frost lens with smooth pattern delivers uniform illumination from corner to corner
- Lens is tough with surface texture to minimize damage from scratches and impact

Compliance

- Indoor luminaires are cULus listed for 25C ambient environments
- IC rated for direct insulation contact
- Damp location listed
- IESNA LM-79 and LM-80 standards compliant
- DesignLights Consortium® Qualified and classified for DLC Standard, refer to www.designlights.org for details.
- FCC part 15 class B (residential) compliant

Warranty

- Five year warranty
- Extended warranty up to 10 years is available

Photometric Data

[View IES files](#)

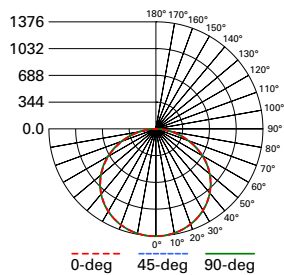

14CGT4040C
 Electronic Driver
 Linear LED 4000K
 Spacing criterion: (II) 1.31 x mounting height, (⊥) 1.31 x mounting height
 Lumens: 4351
 Input Watts: 39.4W
 Efficacy: 110.4 LPW
 Test Report: 14CGT4040C.IES

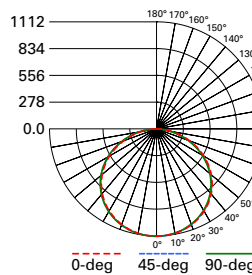

22CGT3540C
 Electronic Driver
 Linear LED 4000K
 Spacing criterion: (II) 1.32 x mounting height, (⊥) 1.32 x mounting height
 Lumens: 3582
 Input Watts: 31.4W
 Efficacy: 114.1 LPW
 Test Report: 22CGT3540C.IES

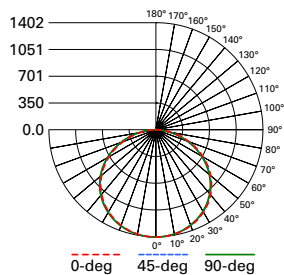

24CGT4540C
 Electronic Driver
 Linear LED 4000K
 Spacing criterion: (II) 1.31 x mounting height, (⊥) 1.31 x mounting height
 Lumens: 4432
 Input Watts: 38.8W
 Efficacy: 114.2 LPW
 Test Report: 24CGT4540C.IES

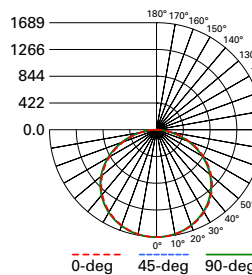

24CGT5540C
 Electronic Driver
 Linear LED 4000K
 Spacing criterion: (II) 1.31 x mounting height, (⊥) 1.31 x mounting height
 Lumens: 5337
 Input Watts: 46.8W
 Efficacy: 114.0 LPW
 Test Report: 24CGT5540C.IES

WAC LIGHTING

Pop-In 4" Round New Construction Downlight

Fixture Type: _____

Catalog Number: _____

Project: _____

Location: _____

Model	Beam	Color Temp & CRI	Lumens	CBCP	Finish
R4DRDN	F 45°	930 3000K - 90	1035	1390	WT White

Example: **R4DRDN-F930-WT**

DESCRIPTION

Minimum profile downlight with driver and electrical connection box attached to fixture for easy remodel or new construction installation.

FEATURES

- Electrical box located on back of fixture to allow easy installation
- Sold as new construction, may be configured in field for remodel
- Driver concealed within the fixture
- 5 year warranty

SPECIFICATIONS

Construction:	Die-cast Aluminum with 20-gauge Cold Rolled Steel Junction Box
Power:	12W
Input:	120-277 VAC, 50/60Hz
Dimming:	TRIAC: 100-5%, ELV: 100-5%
Light Source:	Integrated LED
Lens:	Frosted TIR lens
Mounting:	New construction housings included with hanger bars
Cut Out:	4 1/8"
Finish:	Electrostatically Powder Coated White
Ceiling Thickness:	1/2" - 1 1/2"
Operating Temp:	-4°F to 104°F (-20°C to 40°C)
Standards:	ETL, cETL, Wet Location Listed, Energy Star 2.0, Title 24 JA8-2016 Compliant, IC, Airtight



FINISHES



White

LINE DRAWING

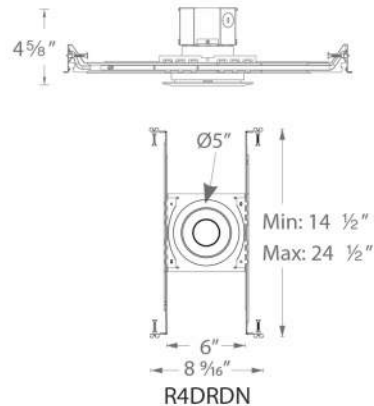

wacighting.com | Phone (800) 526.2588 | Fax (800) 526.2585 | Headquarters/Eastern Distribution Center 44 Harbor Park Drive Port Washington, NY 11050

WAC Lighting retains the right to modify the design of our products at any time as part of the company's continuous improvement program. March 2020



1



D-Series Size 0 LED Area Luminaire



Catalog Number
Notes
Type

Hit the Tab key or mouse over the page to see all interactive elements.

Specifications

- EPA:** 0.95 ft² (.09 m²)
- Length:** 26" (66.0 cm)
- Width:** 13" (33.0 cm)
- Height₁:** 3" (7.62 cm)
- Height₂:** 7" (17.8 cm)
- Weight (max):** 16 lbs (7.25 kg)

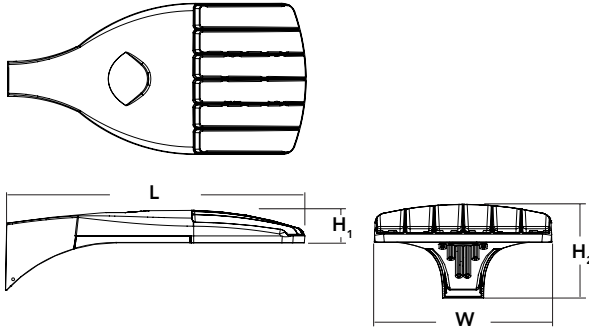

Introduction

The modern styling of the D-Series is striking yet unobtrusive - making a bold, progressive statement even as it blends seamlessly with its environment. The D-Series distills the benefits of the latest in LED technology into a high performance, high efficacy, long-life luminaire. The outstanding photometric performance results in sites with excellent uniformity, greater pole spacing and lower power density. It is ideal for replacing up to 400W metal halide with typical energy savings of 70% and expected service life of over 100,000 hours.

A+ Capable options indicated by this color background.

Ordering Information

EXAMPLE: D SX0 LED P6 40K T3M MVOLT SPA NLTAIR2 PIRHN DDBXD

DSX0 LED	Series	LEDs	Color temperature	Distribution	Voltage	Mounting	
DSX0 LED		Forward optics P1 P4 P7 P2 P5 P3 P6 Rotated optics P10 ¹ P12 ¹ P11 ¹ P13 ¹	30K 3000 K 40K 4000 K 50K 5000 K	T1S Type I short (Automotive) T2S Type II short T2M Type II medium T3S Type III short T3M Type III medium T4M Type IV medium TFTM Forward throw medium TSVS Type V very short ²	T5S Type V short ² T5M Type V medium ² T5W Type V wide ² BLC Backlight control ³ LCCO Left corner cutoff ³ RCCO Right corner cutoff ³	MVOLT ^{4,5} 120 ⁵ 208 ⁵ 240 ⁵ 277 ⁵ 347 ^{5,6} 480 ^{5,6}	Shipped included SPA Square pole mounting RPA Round pole mounting WBA Wall bracket ² SPUMBA Square pole universal mounting adaptor ⁷ RPUMBA Round pole universal mounting adaptor ⁷ Shipped separately KMA8 DDBXD U Mast arm mounting bracket adaptor (specify finish) ⁸

Control options	Other options	Finish (required)
Shipped installed NLTAIR2 nLight AIR generation 2 enabled ^{9,10} PIRHN Network, high/low motion/ambient sensor ¹¹ PER NEMA twist-lock receptacle only (control ordered separate) ¹² PERS Five-pin receptacle only (control ordered separate) ^{12,13} PER7 Seven-pin receptacle only (leads exit fixture) (control ordered separate) ^{12,13} DMG 0-10V dimming extend out back of housing for external control (control ordered separate) ¹⁴	Shipped installed HS House-side shield ¹⁸ SF Single fuse (120, 277, 347V) ⁵ DF Double fuse (208, 240, 480V) ⁵ L90 Left rotated optics ¹ R90 Right rotated optics ¹ DDL Diffused drop lens ¹⁸ Shipped separately BS Bird spikes ¹⁹ EGS External glare shield	DDBXD Dark bronze DBLXD Black DNAXD Natural aluminum DWHXD White DDBTXD Textured dark bronze DBLBXD Textured black DNATXD Textured natural aluminum DWHGXD Textured white



One Lithonia Way • Conyers, Georgia 30012 • Phone: 1-800-705-SERV (7378) • www.lithonia.com
© 2011-2020 Acuity Brands Lighting, Inc. All rights reserved.

DSX0-LED
Rev. 02/05/20
Page 1 of 8

Ordering Information

Accessories

Ordered and shipped separately.

DLL127F 1.5 JU	Photocell - SSL twist-lock (120-277V) ²⁰
DLL347F 1.5 CUL JU	Photocell - SSL twist-lock (347V) ²⁰
DLL480F 1.5 CUL JU	Photocell - SSL twist-lock (480V) ²⁰
DSHORT SBK U	Shorting cap ⁹
DSXHS 20C U	House-side shield for P1,P2,P3 and P4 ¹⁸
DSXHS 30C U	House-side shield for P10,P11,P12 and P13 ¹⁸
DSXHS 40C U	House-side shield for P5,P6 and P7 ¹⁸
DSXODDL U	Diffused drop lens (polycarbonate) ¹⁸
PUMBA DDBXD U ¹	Square and round pole universal mounting bracket adaptor (specify finish) ²¹
KMA8 DDBXD U	Master arm mounting bracket adaptor (specify finish) ⁷
DSXOEGS (FINISH) U	External glare shield

For more control options, visit [DTL](#) and [ROAM](#) online. Link to [nLight Air 2](#)

NOTES

- P10, P11, P12 and P13 and rotated options (L90 or R90) only available together.
- Any Type 5 distribution with photocell, is not available with WBA.
- Not available with HS or DDL.
- MVOLT driver operates on any line voltage from 120-277V (50/60 Hz).
- Single fuse (SF) requires 120V, 277V or 347V. Double fuse (DF) requires 208V, 240V or 480V.
- Not available with BL30, BL50 or PNMT options.
- Universal mounting brackets intended for retrofit on existing pre-drilled poles only. 1.5 G vibration load rating per ANCI C136.31.
- Must order fixture with SPA mounting. Must be ordered as a separate accessory; see Accessories information. For use with 2-3/8" mast arm (not included).
- Must be ordered with PIRHN.
- Sensor cover available only in dark bronze, black, white and natural aluminum colors.
- Must be ordered with NLTAIR2. For more information on nLight Air 2 visit [this link](#).
- Photocell ordered and shipped as a separate line item from Acuity Brands Controls. See accessories. Shorting Cap included.
- If ROAM[®] node required, it must be ordered and shipped as a separate line item from Acuity Brands Controls. Shorting Cap included.
- DMG not available with PIRHN, PER5, PER7, PIR, PIRH, PIR1FC3V or PIRH1FC3V.
- Reference Motion Sensor table on page 3.
- Reference PER Table on page 3 to see functionality.
- Not available with other dimming controls options.
- Not available with BLC, LCCO and RCCO distribution.
- Must be ordered with fixture for factory pre-drilling.
- Requires luminaire to be specified with PER, PER5 or PER7 option. See PER Table on page 3.
- For retrofit use only.

EGS – External Glare Shield

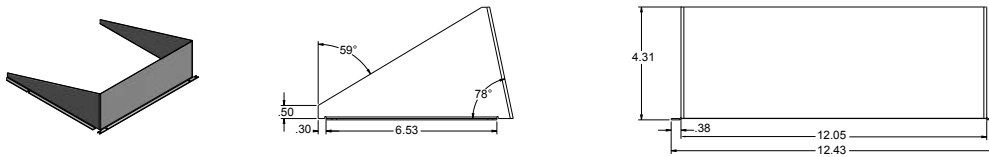

Drilling

HANDHOLE ORIENTATION (from top of pole)

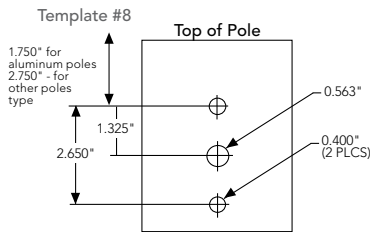
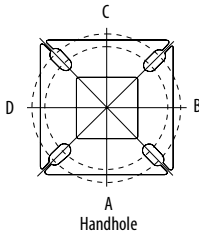

Tenon Mounting Slipfitter

Tenon O.D.	Single Unit	2 at 180°	2 at 90°	3 at 120°	3 at 90°	4 at 90°
2-3/8"	AST20-190	AST20-280	AST20-290	AST20-320	AST20-390	AST20-490
2-7/8"	AST25-190	AST25-280	AST25-290	AST25-320	AST25-390	AST25-490
4"	AST35-190	AST35-280	AST35-290	AST35-320	AST35-390	AST35-490

Mounting Option	Drilling Template	Single	2 @ 180	2 @ 90	3 @ 90	3 @ 120	4 @ 90
Head Location		Side B	Side B & D	Side B & C	Side B, C & D	Round Pole Only	Side A, B, C & D
Drill Nomenclature	#8	DM19AS	DM28AS	DM29AS	DM39AS	DM32AS	DM49AS
Minimum Acceptable Outside Pole Dimension							
SPA	#8	2-7/8"	2-7/8"	3.5"	3.5"		3.5"
RPA	#8	2-7/8"	2-7/8"	3.5"	3.5"	3"	3.5"
SPUMBA	#5	2-7/8"	3"	4"	4"		4"
RPUMBA	#5	2-7/8"	3.5"	5"	5"	3.5"	5"



One Lithonia Way • Conyers, Georgia 30012 • Phone: 1-800-705-SERV (7378) • www.lithonia.com
© 2011-2020 Acuity Brands Lighting, Inc. All rights reserved.

DSX0-LED
Rev. 02/05/20
Page 2 of 8

Photometric Diagrams

To see complete photometric reports or download .ies files for this product, visit Lithonia Lighting's [D-Series Area Size 0 homepage](#).

Isofootcandle plots for the DSX0 LED 40C 1000 40K. Distances are in units of mounting height (20').

LEGEND

- 0.1 fc
- 0.5 fc
- 1.0 fc

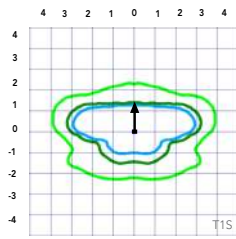

Test No.

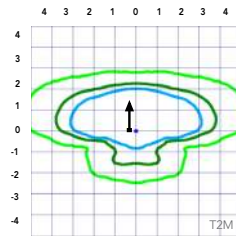

Test No.

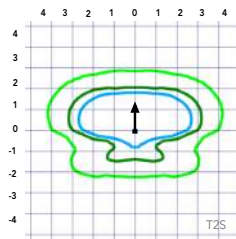

Test No. LT12345/P25 tested in accordance with IESNA LM-79-08.

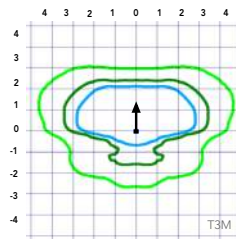

Test No. LT12345/P25 tested in accordance with IESNA LM-79-08.

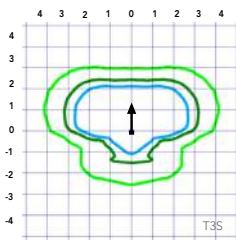

Test No. LT12345/P25 tested in accordance with IESNA LM-79-08.

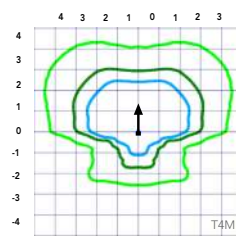

Test No.

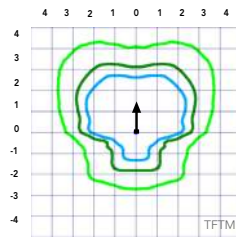

Test No.

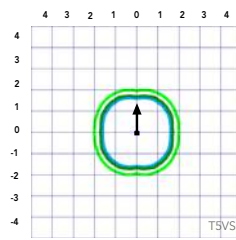

Test No.

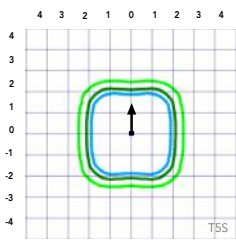

Test No.

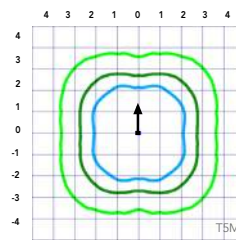

Test No.

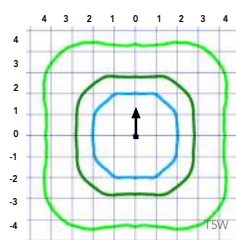

Test No. LT12345/P25 tested in accordance with IESNA LM-79-08.

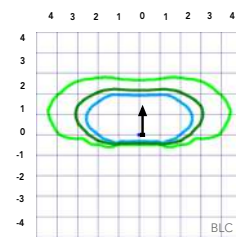

Test No.

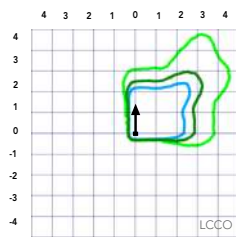

Test No.

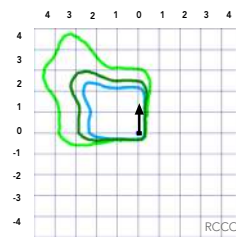

Test No.

Performance Data

Lumen Ambient Temperature (LAT) Multipliers

Use these factors to determine relative lumen output for average ambient temperatures from 0-40°C (32-104°F).

Ambient	Lumen Multiplier
0°C	1.04
5°C	1.04
10°C	1.03
15°C	1.02
20°C	1.01
25°C	1.00
30°C	0.99
35°C	0.98
40°C	0.97

Projected LED Lumen Maintenance

Data references the extrapolated performance projections for the platforms noted in a **25°C ambient**, based on 10,000 hours of LED testing (tested per IESNA LM-80-08 and projected per IESNA TM-21-11).

To calculate LLF, use the lumen maintenance factor that corresponds to the desired number of operating hours below. For other lumen maintenance values, contact factory.

Operating Hours	Lumen Maintenance Factor
25,000	0.96
50,000	0.92
100,000	0.85

Motion Sensor Default Settings						
Option	Dimmed State	High Level (when triggered)	Photocell Operation	Dwell Time	Ramp-up Time	Ramp-down Time
PIR or PIRH	3V (37%) Output	10V (100%) Output	Enabled @ 5FC	5 min	3 sec	5 min
*PIR1FC3V or PIRH1FC3V	3V (37%) Output	10V (100%) Output	Enabled @ 1FC	5 min	3 sec	5 min

*for use with separate Dusk to Dawn or timer.

Controls Options

Nomenclature	Description	Functionality	Primary control device	Notes
FAO	Field adjustable output device installed inside the luminaire; wired to the driver dimming leads.	Allows the luminaire to be manually dimmed, effectively trimming the light output.	FAO device	Cannot be used with other controls options that need the 0-10V leads
DS	Drivers wired independently for 50/50 luminaire operation	The luminaire is wired to two separate circuits, allowing for 50/50 operation.	Independently wired drivers	Requires two separately switched circuits. Consider nLight AIR as a more cost effective alternative.
PERS or PER7	Twist-lock photocell receptacle	Compatible with standard twist-lock photocells for dusk to dawn operation, or advanced control nodes that provide 0-10V dimming signals.	Twist-lock photocells such as DLL Elite or advanced control nodes such as ROAM.	Pins 4 & 5 to dimming leads on driver, Pins 6 & 7 are capped inside luminaire
PIR or PIRH	Motion sensors with integral photocell. PIR for 8-15' mounting; PIRH for 15-30' mounting	Luminaires dim when no occupancy is detected.	Acuity Controls SBGR	Also available with PIRH1FC3V when the sensor photocell is used for dusk-to-dawn operation.
NLTAIR2 PIRHN	nLight AIR enabled luminaire for motion sensing, photocell and wireless communication.	Motion and ambient light sensing with group response. Scheduled dimming with motion sensor over-ride when wirelessly connected to the nLight Eclipse.	nLight Air rSDGR	nLight AIR sensors can be programmed and commissioned from the ground using the CIAIRity Pro app.

Electrical Load

	Performance Package	LED Count	Drive Current	Wattage	Current (A)					
					120	208	240	277	347	480
Forward Optics (Non-Rotated)	P1	20	530	38	0.32	0.18	0.15	0.15	0.10	0.08
	P2	20	700	49	0.41	0.23	0.20	0.19	0.14	0.11
	P3	20	1050	71	0.60	0.37	0.32	0.27	0.21	0.15
	P4	20	1400	92	0.77	0.45	0.39	0.35	0.28	0.20
	P5	40	700	89	0.74	0.43	0.38	0.34	0.26	0.20
	P6	40	1050	134	1.13	0.65	0.55	0.48	0.39	0.29
	P7	40	1300	166	1.38	0.80	0.69	0.60	0.50	0.37
Rotated Optics (Requires L90 or R90)	P10	30	530	53	0.45	0.26	0.23	0.21	0.16	0.12
	P11	30	700	72	0.60	0.35	0.30	0.27	0.20	0.16
	P12	30	1050	104	0.88	0.50	0.44	0.39	0.31	0.23
	P13	30	1300	128	1.08	0.62	0.54	0.48	0.37	0.27

Performance Data

Lumen Output

Lumen values are from photometric tests performed in accordance with IESNA LM-79-08. Data is considered to be representative of the configurations shown, within the tolerances allowed by Lighting Facts. Contact factory for performance data on any configurations not shown here.

Forward Optics																							
Power Package	LED Count	Drive Current	System Watts	Dist. Type	30K (3000 K, 70 CRI)					40K (4000 K, 70 CRI)					50K (5000 K, 70 CRI)								
					Lumens	B	U	G	LPW	Lumens	B	U	G	LPW	Lumens	B	U	G	LPW				
P1	20	530	38W	T1S	4,369	1	0	1	115	4,706	1	0	1	124	4,766	1	0	1	125				
				T2S	4,364	1	0	1	115	4,701	1	0	1	124	4,761	1	0	1	125				
				T2M	4,387	1	0	1	115	4,726	1	0	1	124	4,785	1	0	1	126				
				T3S	4,248	1	0	1	112	4,577	1	0	1	120	4,634	1	0	1	122				
				T3M	4,376	1	0	1	115	4,714	1	0	1	124	4,774	1	0	1	126				
				T4M	4,281	1	0	1	113	4,612	1	0	2	121	4,670	1	0	2	123				
				TFTM	4,373	1	0	1	115	4,711	1	0	2	124	4,771	1	0	2	126				
				TSVS	4,548	2	0	0	120	4,900	2	0	0	129	4,962	2	0	0	131				
				T5S	4,552	2	0	0	120	4,904	2	0	0	129	4,966	2	0	0	131				
				T5M	4,541	3	0	1	120	4,891	3	0	1	129	4,953	3	0	1	130				
				TSW	4,576	3	0	2	120	4,929	3	0	2	130	4,992	3	0	2	131				
				BLC	3,586	1	0	1	94	3,863	1	0	1	102	3,912	1	0	1	103				
				LCCO	2,668	1	0	1	70	2,874	1	0	2	76	2,911	1	0	2	77				
				RCCO	2,668	1	0	1	70	2,874	1	0	2	76	2,911	1	0	2	77				
				P2	20	700	49W	T1S	5,570	1	0	1	114	6,001	1	0	1	122	6,077	2	0	2	124
								T2S	5,564	1	0	2	114	5,994	1	0	2	122	6,070	2	0	2	124
								T2M	5,593	1	0	1	114	6,025	1	0	1	123	6,102	1	0	1	125
T3S	5,417	1	0					2	111	5,835	1	0	2	119	5,909	2	0	2	121				
T3M	5,580	1	0					2	114	6,011	1	0	2	123	6,087	1	0	2	124				
T4M	5,458	1	0					2	111	5,880	1	0	2	120	5,955	1	0	2	122				
TFTM	5,576	1	0					2	114	6,007	1	0	2	123	6,083	1	0	2	124				
TSVS	5,799	2	0					0	118	6,247	2	0	0	127	6,327	2	0	0	129				
T5S	5,804	2	0					0	118	6,252	2	0	0	128	6,332	2	0	1	129				
T5M	5,789	3	0					1	118	6,237	3	0	1	127	6,316	3	0	1	129				
TSW	5,834	3	0					2	119	6,285	3	0	2	128	6,364	3	0	2	130				
BLC	4,572	1	0					1	93	4,925	1	0	1	101	4,987	1	0	1	102				
LCCO	3,402	1	0					2	69	3,665	1	0	2	75	3,711	1	0	2	76				
RCCO	3,402	1	0					2	69	3,665	1	0	2	75	3,711	1	0	2	76				
P3	20	1050	71W					T1S	7,833	2	0	2	110	8,438	2	0	2	119	8,545	2	0	2	120
								T2S	7,825	2	0	2	110	8,429	2	0	2	119	8,536	2	0	2	120
								T2M	7,865	2	0	2	111	8,473	2	0	2	119	8,580	2	0	2	121
				T3S	7,617	2	0	2	107	8,205	2	0	2	116	8,309	2	0	2	117				
				T3M	7,846	2	0	2	111	8,452	2	0	2	119	8,559	2	0	2	121				
				T4M	7,675	2	0	2	108	8,269	2	0	2	116	8,373	2	0	2	118				
				TFTM	7,841	2	0	2	110	8,447	2	0	2	119	8,554	2	0	2	120				
				TSVS	8,155	3	0	0	115	8,785	3	0	0	124	8,896	3	0	0	125				
				T5S	8,162	3	0	1	115	8,792	3	0	1	124	8,904	3	0	1	125				
				T5M	8,141	3	0	2	115	8,770	3	0	2	124	8,881	3	0	2	125				
				TSW	8,204	3	0	2	116	8,838	4	0	2	124	8,950	4	0	2	126				
				BLC	6,429	1	0	2	91	6,926	1	0	2	98	7,013	1	0	2	99				
				LCCO	4,784	1	0	2	67	5,153	1	0	2	73	5,218	1	0	2	73				
				RCCO	4,784	1	0	2	67	5,153	1	0	2	73	5,218	1	0	2	73				
				P4	20	1400	92W	T1S	9,791	2	0	2	106	10,547	2	0	2	115	10,681	2	0	2	116
								T2S	9,780	2	0	2	106	10,536	2	0	2	115	10,669	2	0	2	116
								T2M	9,831	2	0	2	107	10,590	2	0	2	115	10,724	2	0	2	117
T3S	9,521	2	0					2	103	10,256	2	0	2	111	10,386	2	0	2	113				
T3M	9,807	2	0					2	107	10,565	2	0	2	115	10,698	2	0	2	116				
T4M	9,594	2	0					2	104	10,335	2	0	3	112	10,466	2	0	3	114				
TFTM	9,801	2	0					2	107	10,558	2	0	2	115	10,692	2	0	2	116				
TSVS	10,193	3	0					1	111	10,981	3	0	1	119	11,120	3	0	1	121				
T5S	10,201	3	0					1	111	10,990	3	0	1	119	11,129	3	0	1	121				
T5M	10,176	4	0					2	111	10,962	4	0	2	119	11,101	4	0	2	121				
TSW	10,254	4	0					3	111	11,047	4	0	3	120	11,186	4	0	3	122				
BLC	8,036	1	0					2	87	8,656	1	0	2	94	8,766	1	0	2	95				
LCCO	5,979	1	0					2	65	6,441	1	0	2	70	6,523	1	0	3	71				
	5,979	1	0					2	65	6,441	1	0	2	70	6,523	1	0	3	71				

Performance Data

Lumen Output

Lumen values are from photometric tests performed in accordance with IESNA LM-79-08. Data is considered to be representative of the configurations shown, within the tolerances allowed by Lighting Facts. Contact factory for performance data on any configurations not shown here.

Forward Optics																			
Power Package	LED Count	Drive Current	System Watts	Dist. Type	30K (3000 K, 70 CRI)					40K (4000 K, 70 CRI)					50K (5000 K, 70 CRI)				
					Lumens	B	U	G	LPW	Lumens	B	U	G	LPW	Lumens	B	U	G	LPW
P5	40	700	89W	T1S	10,831	2	0	2	122	11,668	2	0	2	131	11,816	2	0	2	133
				T2S	10,820	2	0	2	122	11,656	2	0	2	131	11,803	2	0	2	133
				T2M	10,876	2	0	2	122	11,716	2	0	2	132	11,864	2	0	2	133
				T3S	10,532	2	0	2	118	11,346	2	0	2	127	11,490	2	0	2	129
				T3M	10,849	2	0	2	122	11,687	2	0	2	131	11,835	2	0	2	133
				T4M	10,613	2	0	3	119	11,434	2	0	3	128	11,578	2	0	3	130
				TFTM	10,842	2	0	2	122	11,680	2	0	2	131	11,828	2	0	2	133
				TSVS	11,276	3	0	1	127	12,148	3	0	1	136	12,302	3	0	1	138
				T5S	11,286	3	0	1	127	12,158	3	0	1	137	12,312	3	0	1	138
				T5M	11,257	4	0	2	126	12,127	4	0	2	136	12,280	4	0	2	138
				TSW	11,344	4	0	3	127	12,221	4	0	3	137	12,375	4	0	3	139
				BLC	8,890	1	0	2	100	9,576	1	0	2	108	9,698	1	0	2	109
				LCCO	6,615	1	0	3	74	7,126	1	0	3	80	7,216	1	0	3	81
				RCCO	6,615	1	0	3	74	7,126	1	0	3	80	7,216	1	0	3	81
				P6	40	1050	134W	T1S	14,805	3	0	3	110	15,949	3	0	3	119	16,151
T2S	14,789	3	0					3	110	15,932	3	0	3	119	16,134	3	0	3	120
T2M	14,865	3	0					3	111	16,014	3	0	3	120	16,217	3	0	3	121
T3S	14,396	3	0					3	107	15,509	3	0	3	116	15,705	3	0	3	117
T3M	14,829	2	0					3	111	15,975	3	0	3	119	16,177	3	0	3	121
T4M	14,507	2	0					3	108	15,628	3	0	3	117	15,826	3	0	3	118
TFTM	14,820	2	0					3	111	15,965	3	0	3	119	16,167	3	0	3	121
TSVS	15,413	4	0					1	115	16,604	4	0	1	124	16,815	4	0	1	125
T5S	15,426	3	0					1	115	16,618	4	0	1	124	16,828	4	0	1	126
T5M	15,387	4	0					2	115	16,576	4	0	2	124	16,786	4	0	2	125
TSW	15,506	4	0					3	116	16,704	4	0	3	125	16,915	4	0	3	126
BLC	12,151	1	0					2	91	13,090	1	0	2	98	13,255	1	0	2	99
LCCO	9,041	1	0					3	67	9,740	1	0	3	73	9,863	1	0	3	74
RCCO	9,041	1	0					3	67	9,740	1	0	3	73	9,863	1	0	3	74
P7	40	1300	166W					T1S	17,023	3	0	3	103	18,338	3	0	3	110	18,570
				T2S	17,005	3	0	3	102	18,319	3	0	3	110	18,551	3	0	3	112
				T2M	17,092	3	0	3	103	18,413	3	0	3	111	18,646	3	0	3	112
				T3S	16,553	3	0	3	100	17,832	3	0	3	107	18,058	3	0	3	109
				T3M	17,051	3	0	3	103	18,369	3	0	3	111	18,601	3	0	3	112
				T4M	16,681	3	0	3	100	17,969	3	0	3	108	18,197	3	0	3	110
				TFTM	17,040	3	0	3	103	18,357	3	0	4	111	18,590	3	0	4	112
				TSVS	17,723	4	0	1	107	19,092	4	0	1	115	19,334	4	0	1	116
				T5S	17,737	4	0	2	107	19,108	4	0	2	115	19,349	4	0	2	117
				T5M	17,692	4	0	2	107	19,059	4	0	2	115	19,301	4	0	2	116
				TSW	17,829	5	0	3	107	19,207	5	0	3	116	19,450	5	0	3	117
				BLC	13,971	2	0	2	84	15,051	2	0	2	91	15,241	2	0	2	92
				LCCO	10,396	1	0	3	63	11,199	1	0	3	67	11,341	1	0	3	68
					10,396	1	0	3	63	11,199	1	0	3	67	11,341	1	0	3	68



One Lithonia Way • Conyers, Georgia 30012 • Phone: 1-800-705-SERV (7378) • www.lithonia.com
© 2011-2020 Acuity Brands Lighting, Inc. All rights reserved.

DSX0-LED
Rev. 02/05/20
Page 6 of 8

Performance Data

Lumen Output

Lumen values are from photometric tests performed in accordance with IESNA LM-79-08. Data is considered to be representative of the configurations shown, within the tolerances allowed by Lighting Facts. Contact factory for performance data on any configurations not shown here.

Rotated Optics																			
Power Package	LED Count	Drive Current	System Watts	Dist. Type	30K (3000 K, 70 CRI)					40K (4000 K, 70 CRI)					50K (5000 K, 70 CRI)				
					Lumens	B	U	G	LPW	Lumens	B	U	G	LPW	Lumens	B	U	G	LPW
P10	30	530	53W	T1S	6,727	2	0	2	127	7,247	3	0	3	137	7,339	3	0	3	138
				T2S	6,689	3	0	3	126	7,205	3	0	3	136	7,297	3	0	3	138
				T2M	6,809	3	0	3	128	7,336	3	0	3	138	7,428	3	0	3	140
				T3S	6,585	3	0	3	124	7,094	3	0	3	134	7,183	3	0	3	136
				T3M	6,805	3	0	3	128	7,331	3	0	3	138	7,424	3	0	3	140
				T4M	6,677	3	0	3	126	7,193	3	0	3	136	7,284	3	0	3	137
				TFTM	6,850	3	0	3	129	7,379	3	0	3	139	7,472	3	0	3	141
				TSVS	6,898	3	0	0	130	7,431	3	0	0	140	7,525	3	0	0	142
				T5S	6,840	2	0	1	129	7,368	2	0	1	139	7,461	2	0	1	141
				T5M	6,838	3	0	1	129	7,366	3	0	2	139	7,460	3	0	2	141
				TSW	6,777	3	0	2	128	7,300	3	0	2	138	7,393	3	0	2	139
				BLC	5,626	2	0	2	106	6,060	2	0	2	114	6,137	2	0	2	116
				LCCO	4,018	1	0	2	76	4,328	1	0	2	82	4,383	1	0	2	83
				RCCO	4,013	3	0	3	76	4,323	3	0	3	82	4,377	3	0	3	83
				P11	30	700	72W	T1S	8,594	3	0	3	119	9,258	3	0	3	129	9,376
T2S	8,545	3	0					3	119	9,205	3	0	3	128	9,322	3	0	3	129
T2M	8,699	3	0					3	121	9,371	3	0	3	130	9,490	3	0	3	132
T3S	8,412	3	0					3	117	9,062	3	0	3	126	9,177	3	0	3	127
T3M	8,694	3	0					3	121	9,366	3	0	3	130	9,484	3	0	3	132
T4M	8,530	3	0					3	118	9,189	3	0	3	128	9,305	3	0	3	129
TFTM	8,750	3	0					3	122	9,427	3	0	3	131	9,546	3	0	3	133
TSVS	8,812	3	0					0	122	9,493	3	0	0	132	9,613	3	0	0	134
T5S	8,738	3	0					1	121	9,413	3	0	1	131	9,532	3	0	1	132
T5M	8,736	3	0					2	121	9,411	3	0	2	131	9,530	3	0	2	132
TSW	8,657	4	0					2	120	9,326	4	0	2	130	9,444	4	0	2	131
BLC	7,187	3	0					3	100	7,742	3	0	3	108	7,840	3	0	3	109
LCCO	5,133	1	0					2	71	5,529	1	0	2	77	5,599	1	0	2	78
RCCO	5,126	3	0					3	71	5,522	3	0	3	77	5,592	3	0	3	78
P12	30	1050	104W					T1S	12,149	3	0	3	117	13,088	3	0	3	126	13,253
				T2S	12,079	4	0	4	116	13,012	4	0	4	125	13,177	4	0	4	127
				T2M	12,297	3	0	3	118	13,247	3	0	3	127	13,415	3	0	3	129
				T3S	11,891	4	0	4	114	12,810	4	0	4	123	12,972	4	0	4	125
				T3M	12,290	3	0	3	118	13,239	4	0	4	127	13,407	4	0	4	129
				T4M	12,058	4	0	4	116	12,990	4	0	4	125	13,154	4	0	4	126
				TFTM	12,369	4	0	4	119	13,325	4	0	4	128	13,494	4	0	4	130
				TSVS	12,456	3	0	1	120	13,419	3	0	1	129	13,589	4	0	1	131
				T5S	12,351	3	0	1	119	13,306	3	0	1	128	13,474	3	0	1	130
				T5M	12,349	4	0	2	119	13,303	4	0	2	128	13,471	4	0	2	130
				TSW	12,238	4	0	3	118	13,183	4	0	3	127	13,350	4	0	3	128
				BLC	10,159	3	0	3	98	10,944	3	0	3	105	11,083	3	0	3	107
				LCCO	7,256	1	0	3	70	7,816	1	0	3	75	7,915	1	0	3	76
				RCCO	7,246	3	0	3	70	7,806	4	0	4	75	7,905	4	0	4	76
				P13	30	1300	128W	T1S	14,438	3	0	3	113	15,554	3	0	3	122	15,751
T2S	14,355	4	0					4	112	15,465	4	0	4	121	15,660	4	0	4	122
T2M	14,614	3	0					3	114	15,744	4	0	4	123	15,943	4	0	4	125
T3S	14,132	4	0					4	110	15,224	4	0	4	119	15,417	4	0	4	120
T3M	14,606	4	0					4	114	15,735	4	0	4	123	15,934	4	0	4	124
T4M	14,330	4	0					4	112	15,438	4	0	4	121	15,633	4	0	4	122
TFTM	14,701	4	0					4	115	15,836	4	0	4	124	16,037	4	0	4	125
TSVS	14,804	4	0					1	116	15,948	4	0	1	125	16,150	4	0	1	126
T5S	14,679	3	0					1	115	15,814	3	0	1	124	16,014	3	0	1	125
T5M	14,676	4	0					2	115	15,810	4	0	2	124	16,010	4	0	2	125
TSW	14,544	4	0					3	114	15,668	4	0	3	122	15,866	4	0	3	124
BLC	7,919	3	0					3	62	8,531	3	0	3	67	8,639	3	0	3	67
LCCO	5,145	1	0					2	40	5,543	1	0	2	43	5,613	1	0	2	44
	5,139	3	0					3	40	5,536	3	0	3	43	5,606	3	0	3	44



One Lithonia Way • Conyers, Georgia 30012 • Phone: 1-800-705-SERV (7378) • www.lithonia.com
 © 2011-2020 Acuity Brands Lighting, Inc. All rights reserved.

DSX0-LED
 Rev. 02/05/20
 Page 7 of 8

A+ Capable Luminaire

This item is an A+ capable luminaire, which has been designed and tested to provide consistent color appearance and system-level interoperability.

- All configurations of this luminaire meet the Acuity Brands' specification for chromatic consistency
- This luminaire is A+ Certified when ordered with DTL® controls marked by a shaded background. DTL DLL equipped luminaires meet the A+ specification for luminaire to photocontrol interoperability¹
- This luminaire is part of an A+ Certified solution for ROAM® or XPoint™ Wireless control networks, providing out-of-the-box control compatibility with simple commissioning, when ordered with drivers and control options marked by a shaded background¹

To learn more about A+, visit www.acuitybrands.com/aplus.

1. See ordering tree for details.
2. A+ Certified Solutions for ROAM require the order of one ROAM node per luminaire.
Sold Separately: [Link to Roam](#); [Link to DTL DLL](#)

FEATURES & SPECIFICATIONS

INTENDED USE

The sleek design of the D-Series Size 0 reflects the embedded high performance LED technology. It is ideal for many commercial and municipal applications, such as parking lots, plazas, campuses, and pedestrian areas.

CONSTRUCTION

Single-piece die-cast aluminum housing has integral heat sink fins to optimize thermal management through conductive and convective cooling. Modular design allows for ease of maintenance and future light engine upgrades. The LED driver is mounted in direct contact with the casting to promote low operating temperature and long life. Housing is completely sealed against moisture and environmental contaminants (IP65). Low EPA (0.95 ft²) for optimized pole wind loading.

FINISH

Exterior parts are protected by a zinc-infused Super Durable TGIC thermoset powder coat finish that provides superior resistance to corrosion and weathering. A tightly controlled multi-stage process ensures a minimum 3 mils thickness for a finish that can withstand extreme climate changes without cracking or peeling. Available in both textured and non-textured finishes.

OPTICS

Precision-molded proprietary acrylic lenses are engineered for superior area lighting distribution, uniformity, and pole spacing. Light engines are available in 3000 K, 4000 K or 5000 K (70 CRI) configurations. The D-Series Size 0 has zero uplight and qualifies as a Nighttime Friendly™ product, meaning it is consistent with the LEED® and Green Globes™ criteria for eliminating wasteful uplight.

ELECTRICAL

Light engine(s) configurations consist of high-efficacy LEDs mounted to metal-core circuit boards to maximize heat dissipation and promote long life (up to L85/100,000 hours at 25°C). Class 1 electronic drivers are designed to have a power factor >90%, THD <20%, and an expected life of 100,000 hours with <1% failure rate. Easily serviceable 10kV surge protection device meets a minimum Category C Low operation (per ANSI/IEEE C62.41.2).

STANDARD CONTROLS

The DSX0 LED area luminaire has a number of control options. Dusk to dawn controls can be utilized via optional NEMA twist-lock photocell receptacles. Integrated motion sensors with on-board photocells feature field-adjustable programming and are suitable for mounting heights up to 30 feet.

nLIGHT AIR CONTROLS

The DSX0 LED area luminaire is also available with nLight® AIR for the ultimate in wireless control. This powerful controls platform provides out-of-the-box basic motion sensing and photocontrol functionality and is suitable for mounting heights up to 40 feet. Once commissioned using a smartphone and the easy-to-use CLAIRITY app, nLight AIR equipped luminaires can be grouped, resulting in motion sensor and photocell group response without the need for additional equipment. Scheduled dimming with motion sensor over-ride can be achieved when used with the nLight Eclipse. Additional information about nLight Air can be found [here](#).

INSTALLATION

Included mounting block and integral arm facilitate quick and easy installation. Stainless steel bolts fasten the mounting block securely to poles and walls, enabling the D-Series Size 0 to withstand up to a 3.0 G vibration load rating per ANSI C136.31. The D-Series Size 0 utilizes the AERIS™ series pole drilling pattern (template #8). Optional terminal block and NEMA photocontrol receptacle are also available.

LISTINGS

UL Listed for wet locations. Light engines are IP66 rated; luminaire is IP65 rated. Rated for -40°C minimum ambient. U.S. Patent No. D672,492 S. International patent pending.

DesignLights Consortium® (DLC) Premium qualified product and DLC qualified product. Not all versions of this product may be DLC Premium qualified or DLC qualified. Please check the DLC Qualified Products List at www.designlights.org/QPL to confirm which versions are qualified.

International Dark-Sky Association (IDA) Fixture Seal of Approval (FSA) is available for all products on this page utilizing 3000K color temperature only.

WARRANTY

5-year limited warranty. Complete warranty terms located at: www.acuitybrands.com/support/customer-support/terms-and-conditions

Note: Actual performance may differ as a result of end-user environment and application.

All values are design or typical values, measured under laboratory conditions at 25 °C.

Specifications subject to change without notice.



COMMERCIAL OUTDOOR

One Lithonia Way • Conyers, Georgia 30012 • Phone: 1-800-705-SERV (7378) • www.lithonia.com
© 2011-2020 Acuity Brands Lighting, Inc. All rights reserved.

DSX0-LED
Rev. 02/05/20
Page 8 of 8



FEATURES & SPECIFICATIONS

INTENDED USE — These specifications are for USA standards only. Check with factory for Canadian specifications. Square Straight Aluminum is a general purpose light pole for up to 35-foot mounting heights. This pole provides a lighter and naturally corrosion-resistant option for mounting area light fixtures and floodlights.

CONSTRUCTION — **Pole Shaft:** The pole shaft is of uniform wall thickness and is made of extruded 6000 series aluminum alloy tubing that is heat treated to a T6 temper to provide maximum strength. The shaft is uniformly square in cross-section with flat sides, small corner radii and excellent torsional qualities. Available shaft widths are 4", 5", 6" and 6.75".

Pole Top: Options include tenon top, drilled for side mount fixture, tenon with drilling (includes extra hand-hole) and open top. A cast aluminum top cap is provided for all poles that will receive drilling patterns for side-mount luminaire arm assemblies or when ordered with open top (PT) option. The top cap resists intrusion of moisture and environmental contaminants.

Handhole: A handhole opening with grounding provision is provided near the base. Standard positioning varies with shaft width as follows: 4" shaft, handhole at 12"; 5" shaft, handhole at 14"; 6" and 6.75" shaft, handhole at 18" on side A. Positioning the handhole lower than standard may not be possible and requires engineering review; consult Tech Support-Outdoor for further information. Every handhole includes a cover and cover attachment hardware. The handhole for a pole specified with a 4" or 5" shaft width has a nominal dimension of 2" x 4"; the handhole for a pole specified with a 6" or 6.75" width has a nominal dimension of 2.63" x 5".

Anchor Base/ Cover/ Bolts: Anchor base is cast from 356 alloy aluminum and is supplied with 4 nut cover disks. A full 2-piece cast aluminum anchor base cover is available as an option.

Anchor bolts are manufactured to ASTM F1554 Standards Grade 5S, (55 KSI minimum yield strength and tensile strength of 75-95 KSI). Upper portion of anchor bolt is galvanized per ASTM A-153; bolts have an "L" bend on bottom end and are galvanized a minimum of 12" on the threaded end.

FINISH — Extra durable painted finish is coated with TGIC (Triglycidyl Isocyanurate) Polyester powder that meets 5A and 5B classifications of ASTM D3359. Standard powder-coat finishes include Dark Bronze, White, Black, Medium Bronze and Natural Aluminum colors. Classic finishes include Sandstone, Charcoal Gray, Tennis Green, Bright Red and Steel Blue colors. Other finishes include Brushed Aluminum, and Anodized Dark Bronze, Anodized Natural Aluminum and Anodized Black. Architectural Colors and Special Finishes are available by quote and include, but are not limited to RAL Colors, Custom Colors and Extended Warranty Finishes. Factory-applied primer paint finish is available for customer field-paint applications.

WARRANTY — 1-year limited warranty. Complete warranty terms located at: www.acuitybrands.com/CustomerResources/Terms_and_conditions.aspx

NOTE: Actual performance may differ as a result of end-user environment and application.

Catalog Number
Notes
Type



Anchor Base Poles

SSA

SQUARE STRAIGHT ALUMINUM

Specifications subject to change without notice.

See footnotes next page.

OUTDOOR

POLE-SSA

SSA Square Straight Aluminum Poles

ORDERING INFORMATION

Lead times will vary depending on options selected. Consult with your sales representative.

Example: SSA 20 4C DM19 BA

SSA Series	Nominal fixture mounting height	Nominal shaft base size/wall thickness	Mounting ²	Options	Finish ¹⁰
SSA	8'-35' (for 1/2 ft increments, add -6 to the pole height. Ex: 20-6 equals 20ft 6in.) (See technical information table for complete ordering information.)	(See technical information table for complete ordering information.)	Tenon mounting PT Open top T20 2-3/8" O.D. (2" NPS) T25 2-7/8" O.D. (2-1/2" NPS) T30 3-1/2" O.D. (3" NPS) ³ T35 4" O.D. (3-1/2" NPS) ³ Drill mounting⁴ DM19 1 at 90° DM28 2 at 180° DM28PL 2 at 180° with one side plugged DM29 2 at 90° DM39 3 at 90° DM49 4 at 90° CSX/DSX/AERIS™/OMERO™/HLA/KAX Drill mounting⁴ DM19AS 1 at 90° DM28AS 2 at 180° DM29AS 2 at 90° DM39AS 3 at 90° DM49AS 4 at 90° AERIS™ Suspend drill mounting^{4,5} DMxxAST_ OMERO™ Suspend drill mounting^{4,5} DMxxMRT_	Shipped installed L/AB Less anchor bolts (Include when anchor bolts are not needed) VD Vibration damper TP Tamper proof HAXy Horizontal arm bracket (1 fixture) ^{6,7} FDLxy Festoon outlet less electrical ⁶ CPL12/xy 1/2" coupling ⁶ CPL34/xy 3/4" coupling ⁶ CPL1/xy 1" coupling ⁶ NPL12/xy 1/2" threaded nipple ⁶ NPL34/xy 3/4" threaded nipple ⁶ NPL1/xy 1" threaded nipple ⁶ EHHxy Extra handhole ^{6,8} MAEX Match existing ⁹ USPOM United States point of manufacture ¹⁰ UL UL listed wit label (Includes NEC compliant cover) NEC NEC 410.30 compliant gasketed handhole (Not UL Labeled) Shipped separately (replacement kit available) (blank) BLTC Bolt caps FBC Full base cover (spun aluminum) (blank) TC Top cap (with drill-mount poles) (blank) HHC Handhole cover	Standard colors DDBXD Dark bronze DWH White DBLXD Black DMB Medium bronze DNA Natural aluminum Brushed Finish BA Brushed aluminum Classic colors DSS Sandstone DGC Charcoal gray DTG Tennis green DBR Bright red DSB Steel blue Class 1 architectural anodized ABL Black ADB Dark bronze ANA Natural Architectural colors (powder finish)¹¹

NOTES

- Wall thickness will be signified by the letter "C", "G" or "J". C represents a 0.125" thickness, "G" represents a 0.188 thickness and "J" represents a 0.250" thickness.
- When ordering tenon mounting and drill mounting for the same pole, follow this example: DM28/T20. The combination includes a required extra handhole.
- 3-1/2" and 4" O.D. tenons available on 5" and 6" shafts only.
- Refer to the fixture spec sheet for the correct drilling template pattern and orientation compatibility. Refer to the Anchor Bolt Matrix with Generic Template Link at <http://www.acuitybrands.com/-/media/Files/Acuity/Resources/Tools-and-Documents/Pole%20Resources/Pole%20Anchorage/Matrix%20Document/AnchorBoltMatrix.pdf?la=en>
- Insert "1" or "2" to designate fixture size; e.g. DM19AST2.
- Specify location and orientation when ordering option. For "x": Specify the height in feet above base of pole. Example: 5ft = 5 and 20ft, 3in = 20-3 For "y": Specify orientation from handhole (A,B,C,D) Refer to the Handhole Orientation diagram on this page. Example: 1/2" coupling at 5'8", orientation C: SSA 20 4C DM19 CPL12/5-8C DDB
- Horizontal arm is 18" x 2-3/8" O.D. tenon standard, with radius curve providing 12" rise and 2-3/8" O.D. If ordering two horizontal arm at the same height, specify with HAXxy. Example: HA20BD
- Combination of tenon-top and drill mount includes extra handhole.
- Must add original order number
- Use when mill certifications are required.
- Finish must be specified. Additional colors available; see www.lithonia.com/archcolors or Architectural Colors brochure (Form No. 794.3).



POLE-SSA

OUTDOOR: One Lithonia Way Conyers, GA 30012 Phone: 770-922-9000 www.lithonia.com

©1994-2018 Acuity Brands Lighting, Inc. All rights reserved.

Rev. 11/15/18

SSA Square Straight Aluminum Poles

TECHNICAL INFORMATION — EPA (ft ²) with 1.3 gust									
Catalog number	Nominal mount ht. (ft) *	Pole shaft size (in x ft)	Wall thick (in)	80 mph	90 mph	100 mph	Max. weight (lbs)	Bolt size (in. x in. x in.)	Approximate ship (lbs.)
SSA 8 4C	8	4.0 x 8.0	0.125	16.5	12.6	9.9	300	3/4 x 18 x 3	32
SSA 10 4C	10	4.0 x 10.0	0.125	11.5	8.6	6.5	230	3/4 x 18 x 3	37
SSA 12 4C	12	4.0 x 12.0	0.125	12.4	9.2	6.9	160	3/4 x 18 x 3	40
SSA 14 4C	14	4.0 x 14.0	0.125	9.3	6.7	4.8	120	3/4 x 18 x 3	50
SSA 15 4C	15	4.0 x 15.0	0.125	8	5.6	3.9	100	3/4 x 18 x 3	52
SSA 16 4C	16	4.0 x 16.0	0.125	6.9	4.7	3.1	90	3/4 x 18 x 3	54
SSA 16 4G	16	4.0 x 16.0	0.188	11.8	8.5	6.2	130	3/4 x 30 x 3	74
SSA 16 5G	16	5.0 x 16.0	0.188	15	11.1	7.5	280	3/4 x 30 x 3	83
SSA 18 4C	18	4.0 x 18.0	0.125	4.9	3	1.7	70	3/4 x 18 x 3	57
SSA 18 4G	18	4.0 x 18.0	0.188	9.2	6.4	4.4	100	3/4 x 30 x 3	80
SSA 18 5G	18	5.0 x 18.0	0.188	16.8	12.2	8.9	230	3/4 x 30 x 3	91
SSA 20 4C	20	4.0 x 20.0	0.125	3.3	1.7	0.5	40	3/4 x 18 x 3	62
SSA 20 4G	20	4.0 x 20.0	0.188	7	4.6	2.9	80	3/4 x 30 x 3	85
SSA 20 5G	20	5.0 x 20.0	0.188	13.6	9.5	6.6	180	3/4 x 30 x 3	107
SSA 20 6G	20	6.0 x 20.0	0.188	22	15.9	11.6	230	1 x 36 x 4	155
SSA 20 6J	20	6.0 x 20.0	0.25	30.4	22.6	17	300	1 x 36 x 4	202
SSA 25 5G	25	5.0 x 25.0	0.188	7.2	4.2	2	110	3/4 x 30 x 3	130
SSA 25 6G	25	6.0 x 25.0	0.188	13.2	8.6	5.4	180	1 x 36 x 4	180
SSA 25 6J	25	6.0 x 25.0	0.25	19.7	13.8	9.5	250	1 x 36 x 4	224
SSA 30 6G	30	6.0 x 30.0	0.188	7	3.4	0.8	130	1 x 36 x 4	210
SSA 30 6J	30	6.0 x 30.0	0.25	12.2	7.5	4.1	170	1 x 36 x 4	258
SSA 32 6J	32	6.0 x 32.0	0.25	9.7	5.4	2.3	160	1 x 36 x 4	272
SSA 35 6J	35	6.0 x 35.0	0.25	6.4	2.6	--	200	1 x 36 x 4	294
SSA 35 7J	35	6.75 x 35.0	0.25	7.6	3.1	--	150	1 x 36 x 4	290

* EPA values are based ASCE 7-93 wind map. For 1/2 ft increments, add -6 to the pole height. Ex: 20-6 equals 20ft 6in.

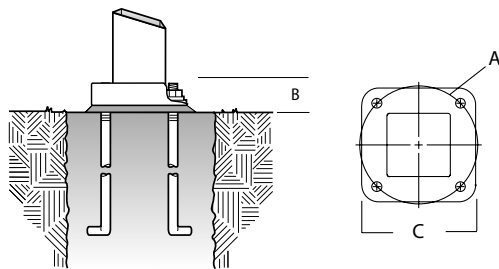

POLE DATA						
Shaft base size	Bolt circle (in) A	Bolt projection (in) B	Base square (in) C	Bolt Size	Template description	Anchor bolt description
4C	8.5 - 9.625	3.125	9.938	3/4 x 18 x 3	ABTEMPLATE PJ50045	AB18-0
4G	8.5 - 9.625	3.125	9.938	3/4 x 30 x 3	ABTEMPLATE PJ50045	AB30-0
5	10.5 - 11.5	3.25	11.563	3/4 x 30 x 3	ABTEMPLATE PJ50046	AB30-0
6	12-13	4	12.25	1 x 36 x 4	ABTEMPLATE PJ50044	AB36-0
7	14.625	4.125	15	1 x 36 x 4	ABTEMPLATE PJ50130	AB36-0

HANDHOLE ORIENTATION

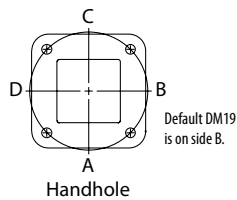

IMPORTANT INSTALLATION NOTES:

- Do not erect poles without having fixtures installed.
- Factory-supplied templates must be used when setting anchor bolts. Lithonia Lighting will not accept claim for incorrect anchorage placement due to failure to use factory template.
- If poles are stored outside, all protective wrapping must be removed immediately upon delivery to prevent finish damage.
- Lithonia Lighting is not responsible for the foundation design.



POLE-SSA

OUTDOOR: One Lithonia Way Conyers, GA 30012 Phone: 770-922-9000 www.lithonia.com

©1994-2018 Acuity Brands Lighting, Inc. All rights reserved.

Rev. 11/15/18

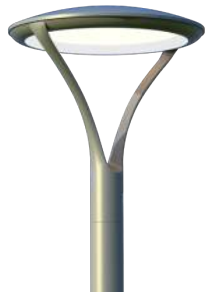

Radean Post Top LED Area Luminaire



Catalog
Number

Notes

Type

Hit the Tab key or mouse over the page to see all interactive elements.

Specifications

EPA: 1.02 ft²
(0.105 m²)

Length: 24"
(61cm)

Width: 24"
(61cm)

**H1
Luminaire
Height:** 4"
(10.16cm)

**H2
Luminaire
Height:** 26"
(66.04cm)

Weight: 38lbs
(17.24Kg)

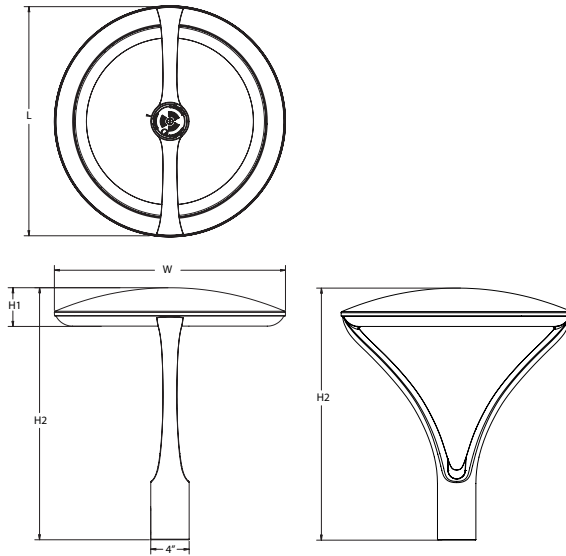

Introduction

The architecturally-inspired shape of the RADEAN™ post top area luminaire embodies the grace and strength of the RADEAN family. The twin copper-core cast aluminum arms support the slender superstructure, creating a beautiful sculpture by day transforming into a beacon of comfort by night. Triangular arms redirect reflection maintaining its visually quiet appearance. With sleek lines and simple silhouettes, these LED luminaires use specialized lighting and visual comfort to transform common areas like courtyards, outdoor retail locations, universities and corporate campuses into pedestrian-friendly nighttime environments.

Ordering Information

EXAMPLE: RADPT LED P3 30K SYM MVOLT PT4 PIR DNAXD

RADPT LED						
Series	Performance package	Color temperature	Distribution	Voltage		Mounting (required)
RADPT LED	P1 3,000 Lumens	27K 2700K	SYM Symmetric type V	MVOLT ¹	277 ¹	PT4 ² Slips inside a 4" OD round metal pole
	P2 5,000 Lumens	30K 3000K	ASY Asymmetric type IV	120 ¹	347	RADPT20 Slips over a 2 3/8" diameter tenon
	P3 7,000 Lumens	35K 3500K	PATH Pathway Type III	208 ¹	480	RADPT25 Slips over a 2 7/8" diameter tenon
	P4 10,000 Lumens	40K 4000K		240 ¹		
	P5 15,000 Lumens	50K 5000K				

Control options	Other options		Finish (required)			
Shipped installed	SF Single Fuse ¹	Shipped installed	DDBXD Dark bronze	DBBTXD Textured dark bronze		
NLTAIR2 nLight AIR 2.0 enabled ³	DF Double Fuse ¹	HS Houseside shield ¹⁰	DBLXD Black	DBLBXD Textured black		
PIR Bi-level motion/sensor (100% to 30%) ^{4,5,6,7}	R90 Rotated optics ⁹		DNAXD Natural aluminum	DNATXD Textured natural aluminum		
PE Button photocell ⁶			DWHXD White	DWHGXD Textured white		
FAO Field adjustable output ^{4,8}						



COMMERCIAL OUTDOOR

One Lithonia Way • Conyers, Georgia 30012 • Phone: 1-800-705-SERV (7378) • www.lithonia.com
© 2011-2020 Acuity Brands Lighting, Inc. All rights reserved.

RADPT LED
Rev. 05/05/20

Ordering Information

Accessories

Ordered and shipped separately.

RADHS	Houseside shield (shield is white)
RADCS DDBXD U	Decorative clamshell base for 4" RSS pole (specify finish)
RADFBC DDBXD U	Full base cover for 4" RSS pole (specify finish)

For more control options, visit [DTL](#) and [ROAM](#) online.

NOTES

- 1 MVOLT driver operates on any line voltage from 120-277V (50/60 Hz). Single fuse (SF) requires 120, 277 or 347 voltage option. Double fuse (DF) requires 208, 240 or 480 voltage option.
- 2 Required nominal 4" round straight metal pole.
- 3 NLTAIR2 not available with PIR, PE or FAO. Must link to external nLight Air network.
- 4 PIR will work with FAO, if adjustable low-end trim is required.
- 5 PIR must specify 120V, 277V, 347V or 480V. Not available in MVOLT, 208V or 240V.
- 6 PE and PIR are available together.
- 7 PIR for use on mounting heights under 20'.
- 8 Field adjustable high-end trim.
- 9 For left rotation, select R90 and rotate luminaire 180° on pole.
- 10 Also available as a separate accessory; see Accessories information at left. HS not available with R90. Shield is field rotatable shield in 180° increments.

Mounting

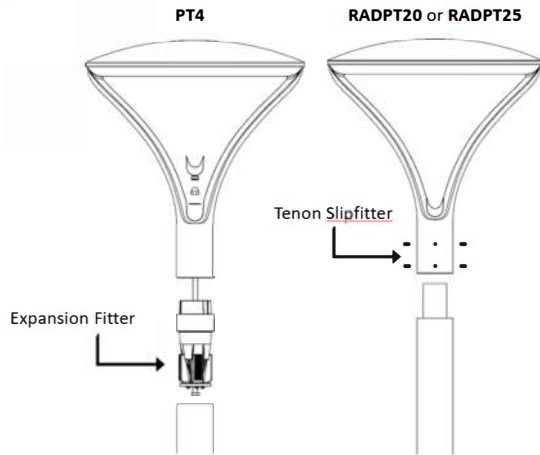

Recommended Poles for use with RADEAN RADPT LED Luminaires.

Acuity Part Number	Description	For luminaires	Used with Mounting
RSS 10 4B PT DDBXD	10' Round Straight Steel - 4" O.D. - Open Top	RADPT LED	PT4
RSS 12 4B PT DDBXD	12' Round Straight Steel - 4" O.D. - Open Top	RADPT LED	PT4
RSS 14 4B PT DDBXD	14' Round Straight Steel - 4" O.D. - Open Top	RADPT LED	PT4
RSS 16 4B PT DDBXD	16' Round Straight Steel - 4" O.D. - Open Top	RADPT LED	PT4
RSS 18 4B PT DDBXD	18' Round Straight Steel - 4" O.D. - Open Top	RADPT LED	PT4
RSS 20 4B PT DDBXD	20' Round Straight Steel - 4" O.D. - Open Top	RADPT LED	PT4
RSS 25 4B PT DDBXD	25' Round Straight Steel - 4" O.D. - Open Top	RADPT LED	PT4
RSS 10 4B T20 DDBXD	10' Round Straight Steel - 4" O.D. - Tenon Top	RADPT LED	RADPT20
RSS 12 4B T20 DDBXD	12' Round Straight Steel - 4" O.D. - Tenon Top	RADPT LED	RADPT20
RSS 14 4B T20 DDBXD	14' Round Straight Steel - 4" O.D. - Tenon Top	RADPT LED	RADPT20
RSS 16 4B T20 DDBXD	16' Round Straight Steel - 4" O.D. - Tenon Top	RADPT LED	RADPT20
RSS 18 4B T20 DDBXD	18' Round Straight Steel - 4" O.D. - Tenon Top	RADPT LED	RADPT20
RSS 20 4B T20 DDBXD	20' Round Straight Steel - 4" O.D. - Tenon Top	RADPT LED	RADPT20
RSS 25 4B T20 DDBXD	25' Round Straight Steel - 4" O.D. - Tenon Top	RADPT LED	RADPT20

* Customer must verify pole loading per required design criteria and specified wind speed. Consult pole specification sheet for additional details.

Control Options

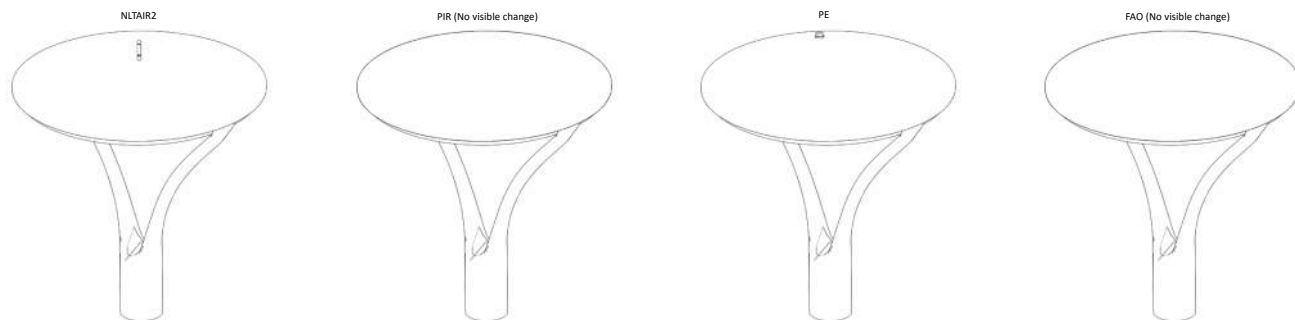

COMMERCIAL OUTDOOR

One Lithonia Way • Conyers, Georgia 30012 • Phone: 1-800-705-SERV (7378) • www.lithonia.com
© 2011-2020 Acuity Brands Lighting, Inc. All rights reserved.

RADPT LED
Rev. 05/05/20

Performance Data

Lumen Output

Lumen values are from photometric tests performed in accordance with IESNA LM-79-08. Data is considered to be representative of the configurations shown. Contact factory for performance data on any configurations not shown here.

Performance Package	Input Wattage	Distribution	2700K					3000K					3500K					4000K					5000K				
			Lumens	B	U	G	LPW	Lumens	B	U	G	LPW	Lumens	B	U	G	LPW	Lumens	B	U	G	LPW	Lumens	B	U	G	LPW
P1	25	ASY	2,924	2	1	2	115	3,022	2	2	2	119	3,095	2	2	2	122	3,168	2	2	2	125	3,168	2	2	2	125
		PATH	2,529	2	1	2	100	2,613	2	2	2	103	2,676	2	2	2	105	2,739	2	2	2	108	2,739	2	2	2	108
		SYM	3,086	2	1	1	121	3,189	2	1	1	126	3,266	2	1	1	129	3,344	2	1	1	132	3,344	2	1	1	132
P2	38	ASY	4,521	3	2	3	119	4,672	3	2	3	123	4,785	3	2	3	126	4,898	3	2	3	129	4,898	3	2	3	129
		PATH	3,909	2	2	2	103	4,040	2	2	2	106	4,137	2	2	2	109	4,235	3	2	3	111	4,235	3	2	3	111
		SYM	4,772	2	2	1	126	4,931	3	2	1	130	5,050	3	2	1	133	5,169	3	2	1	136	5,169	3	2	1	136
P3	54	ASY	6,387	3	2	3	119	6,600	3	2	3	123	6,760	3	2	3	126	6,919	3	2	3	129	6,919	3	2	3	129
		PATH	5,523	3	2	3	103	5,707	3	2	3	106	5,845	3	2	3	109	5,983	3	2	3	112	5,983	3	2	3	112
		SYM	6,741	3	2	2	126	6,966	3	2	2	130	7,135	3	2	2	133	7,303	3	2	2	136	7,303	3	2	2	136
P4	86	ASY	10,150	4	2	4	118	10,489	4	2	4	122	10,742	4	2	4	125	10,996	4	2	4	128	10,996	4	2	4	128
		PATH	8,777	3	2	3	102	9,070	3	2	3	106	9,289	3	2	3	108	9,509	3	2	3	111	9,509	3	2	3	111
		SYM	10,713	3	2	2	125	11,071	3	2	2	129	11,338	3	2	2	132	11,606	3	2	2	135	11,606	3	2	2	135
P5	123	ASY	14,250	4	2	4	116	14,724	4	2	4	120	15,081	4	3	4	123	15,437	4	3	4	126	15,437	4	3	4	126
		PATH	12,322	4	2	4	101	12,733	4	3	4	104	13,041	4	3	4	106	13,349	4	3	4	109	13,349	4	3	4	109
		SYM	15,040	4	2	3	123	15,541	4	2	3	127	15,917	4	2	3	130	16,293	4	2	3	133	16,293	4	2	3	133

Lumen Ambient Temperature (LAT) Multipliers

Use these factors to determine relative lumen output for average ambient temperatures from 0-40°C (32-104°F).

Ambient		LAT Factor
0°C	32°F	1.06
5°C	41°F	1.05
10°C	50°F	1.04
15°C	59°F	1.02
20°C	68°F	1.01
25°C	77°F	1.00
30°C	86°F	0.99
35°C	95°F	0.98
40°C	104°F	0.96

Projected LED Lumen Maintenance

Data references the extrapolated performance projections for the RADPT LED platform in a **25°C ambient**, based on 10,000 hours of LED testing (tested per IESNA LM-80-08 and projected per IESNA TM-21-11).

To calculate LLF, use the lumen maintenance factor that corresponds to the desired number of operating hours below. For other lumen maintenance values, contact factory.

	Projected LED Lumen Maintenance			
	0	25,000	50,000	100,000
P1	1.00	0.96	0.91	0.82
P2	1.00	0.96	0.91	0.82
P3	1.00	0.96	0.91	0.82
P4	1.00	0.96	0.91	0.82
P5	1.00	0.95	0.89	0.78

Electrical Load

Lumen Package	LED Drive Current	Voltage	Wattage	Current (A)						
				120	208	240	277	347	480	
P1	500	42.8	21.4	Input Current	0.22	0.13	0.11	0.1	0.08	0.06
				System Watts	26	26	26	27	25	26
P2	770	43	33.1	Input Current	0.33	0.19	0.16	0.14	0.11	0.08
				System Watts	39	39	39	39	38	38
P3	1100	43.2	47.5	Input Current	0.46	0.26	0.23	0.2	0.16	0.12
				System Watts	55	54	54	54	54	54
P4	900	87.3	78.6	Input Current	0.73	0.42	0.36	0.32	0.25	0.18
				System Watts	87	86	86	86	86	86
P5	1250	88.2	110.2	Input Current	1	0.58	0.5	0.44	0.35	0.25
				System Watts	120	119	119	119	120	120



COMMERCIAL OUTDOOR

One Lithonia Way • Conyers, Georgia 30012 • Phone: 1-800-705-SERV (7378) • www.lithonia.com
© 2011-2020 Acuity Brands Lighting, Inc. All rights reserved.

RADPT LED
Rev. 05/05/20

Orientation Diagrams

To see complete photometric reports or download .ies files for this product, visit Lithonia Lighting's [RADPT LED homepage](#).

Isofootcandle plots are considered to be representative of available optical distributions.

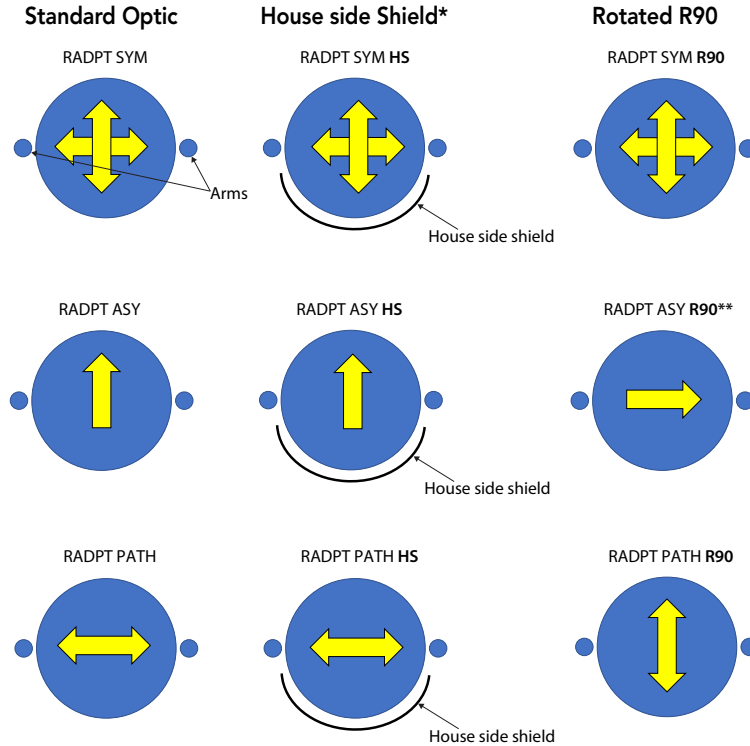

*HS not available with R90

**For L90, use R90 and rotate luminaire 180° on pole

FEATURES & SPECIFICATIONS

INTENDED USE

Pedestrian areas such as parks, campuses, pathways, courtyards and pedestrians malls.

CONSTRUCTION

Single-piece die-cast aluminum housing with nominal wall thickness of 0.125" on a 6mm thick acrylic waveguide is fully gasketed with a single piece tubular silicone gasket.

FINISH

Exterior parts are protected by a zinc-infused Super Durable TGIC thermoset powder coat finish that provides superior resistance to corrosion and weathering. A tightly controlled multi-stage process ensures a minimum 3 mils thickness for a finish that can withstand extreme climate changes without cracking or peeling. Standard Super Durable colors include dark bronze, black, natural aluminum and white. Available in textured and non-textured finishes.

OPTICS

6MM thick acrylic waveguide with 360° flexible LED board. Available in 2700K, 3000K, 3500K, 4000K and 5000K (70CRI) CCT configurations.

ELECTRICAL

Light engine consists of 96 high-efficacy LEDs mounted to a flexible circuit board and aluminum heat sink, ensuring optimal thermal management and long life. Class 1 electronic driver has a power factor >90%, THD <20%, and has an expected life of 100,000 hours with <1% failure rate. Easily-serviceable 10kV surge protection device meets a minimum Category C Low for operation (per ANSI/IEEE C62.41.2).

INSTALLATION

Standard post-top mounting configuration fits into a 4" OD open pole top (round pole only). Alternate tenon (2-3/8" or 2-7/8") mounting also available.

LISTINGS

CSA certified to U.S. and Canadian standards. Luminaire is IP65 rated. Rated for -40°C minimum ambient.

DesignLights Consortium® (DLC) Premium qualified product and DLC qualified product. Not all versions of this product may be DLC Premium qualified or DLC qualified. Please check the DLC Qualified Products List at www.designlights.org/QPL to confirm which versions are qualified.

International Dark-Sky Association (IDA) Fixture Seal of Approval (FSA) is available for all products on this page utilizing 3000K color or less.

WARRANTY

5-year limited warranty. Complete warranty terms located at:

www.acuitybrands.com/support/customer-support/terms-and-conditions

Note: Actual performance may differ as a result of end-user environment and application. All values are design or typical values, measured under laboratory conditions at 25 °C. Specifications subject to change without notice.



COMMERCIAL OUTDOOR

One Lithonia Way • Conyers, Georgia 30012 • Phone: 1-800-705-SERV (7378) • www.lithonia.com
© 2011-2020 Acuity Brands Lighting, Inc. All rights reserved.

RADPT LED
Rev. 05/05/20

Catalog Number
Notes
Type

FEATURES & SPECIFICATIONS

INTENDED USE — These specifications are for USA standards only. Check with factory for Canadian specifications. Round Straight Aluminum is a general purpose light pole for up to 30-foot mounting heights. This pole provides a lighter and naturally corrosion-resistant option for mounting area light fixtures and floodlights.

CONSTRUCTION — **Pole Shaft:** The pole shaft is of uniform wall thickness and is one-piece extruded 6063 aluminum alloy with T6 temper. The shaft is uniform in cross-section down length of pole with no taper. Available shaft diameters are 4", 4.5" 5", and 6".

Pole Top: Options include tenon top, drilled for side mount fixture, tenon with drilling (includes extra handhole) and open top. Side drilled and open top poles include a removable aluminum top cap secured with three stainless-steel screws. The top cap resists intrusion of moisture or environmental contaminants.

Handhole: A non-reinforced handhole with grounding provision is provided near the base. Standard positioning varies with shaft width as follows: 4", 4.5", and 5" shaft, handhole at 12"; 6" shaft, handhole at 18" on side A. Positioning the handhole lower than standard may not be possible and requires engineering review; consult Tech Support-Outdoor for further information. All handholes for a pole specified with openings wfor 4" through 6" shaft width has nominal dimension of 2" x 4" with surface mount overlap design.

Bolt Caps/Base Cover: Pole base plate utilizes cast aluminum bolt caps to cover anchor bolt and nut assembly. Spun aluminum covers available as an option.

Anchor Base/Bolts: Anchor base is cast from 356 alloy aluminum and is heat treated to a T6 temper after welding. Anchor bolts are manufactured to ASTM F1554 Standards Grade 55, (55 KSI minimum yield strength and tensile strength of 75-95 KSI). Upper portion of anchor bolt is galvanized per ASTM A-153; bolts have an "L" bend on bottom end and are galvanized a minimum of 12" on the threaded end. Each hot-dipped galvanized anchor bolt is furnished with two hex nuts and two flat washers.

HARDWARE — All structural and non-structural fasteners are stainless-steel.

FINISH — Extra durable painted finish is coated with polyester powder that meets 5A and 5B classifications of ASTM D3359. Standard powder-coat finishes include Dark Bronze, White, Black, Medium Bronze and Natural Aluminum colors. Classic finishes include Sandstone, Charcoal Gray, Tennis Green, Bright Red and Steel Blue colors. Other finishes include Brushed Aluminum, and Anodized Dark Bronze, Anodized Natural Aluminum and Anodized Black. Architectural Colors and Special Finishes are available by quote and include, but are not limited to RAL Colors, Custom Colors and Extended Warranty Finishes. Factory-applied primer paint finish is available for customer field-paint applications.

WARRANTY — 1-year limited warranty. Complete warranty terms located at: www.acuitybrands.com/CustomerResources/Terms_and_conditions.aspx

NOTE: Actual performance may differ as a result of end-user environment and application. Specifications subject to change without notice.

Anchor Base Poles



RSA

ROUND STRAIGHT ALUMINUM

RSA Round Straight Aluminum Poles

ORDERING INFORMATION

Lead times will vary depending on options selected. Consult with your sales representative.

Example: RSA 16 4-5C DM19 BA

RSA Series	Nominal fixture mounting height	Nominal shaft base size/wall thickness ¹	Mounting ¹	Options	Finish ¹⁰
RSA	8'-30" (for 1/2 ft increments, add -6 to the pole height. Ex: 20-6 equals 20ft 6in.) (See technical information table for complete ordering information.)	4C 4" (.125") 4-5C 4 1/2" (.125") 4-5G 4 1/2" (.188") 5C 5" (.125") 5E 5" (.156") 5G 5" (.188") 6E 6" (.156") 6G 6" (.188") (See technical information table for complete ordering information.)	<u>Tenon mounting</u> PT Open top T20 2-3/8" O.D. (2" NPS) T25 2-7/8" O.D. (2-1/2" NPS) T30 3-1/2" O.D. (3" NPS) ² T35 4" O.D. (3-1/2" NPS) ² <u>KAC/KAD/KSE/KSF/KVR/KVF Drill mounting³</u> DM19 1 at 90° DM28 2 at 180° DM28PL 2 at 180° with one side plugged DM29 2 at 90° DM32 3 at 120° DM39 3 at 90° DM49 4 at 90° <u>CSX/DSX/RSX/AERIS™/OMERO™/HLA/KAX Drill mounting³</u> DM19AS 1 at 90° DM28AS 2 at 180° DM29AS 2 at 90° DM32AS 3 at 120° DM39AS 3 at 90° DM49AS 4 at 90° <u>RAD drill mounting³</u> DM19RAD 1 at 90° DM28RAD 2 at 180° DM29RAD 2 at 90° DM32RAD 3 at 120° DM39RAD 3 at 90° DM49RAD 4 at 90° <u>AERIS™ Suspend drill mounting^{3,4}</u> DM19AST_ 1 at 90° DM28AST_ 2 at 180° DM29AST_ 2 at 90° DM39AST_ 3 at 90° DM49AST_ 4 at 90° <u>OMERO™ Suspend drill mounting^{3,4}</u> DM19MRT_ 1 at 90° DM28MRT_ 2 at 180° DM29MRT_ 2 at 90° DM39MRT_ 3 at 90° DM49MRT_ 4 at 90°	<u>Shipped installed</u> L/AB Less anchor bolts (Include when anchor bolts are not needed) VD Vibration damper TP Tamper resistant handhole cover fasteners HAxy Horizontal arm bracket (1 fixture) ^{5,6} FDLxy Festoon outlet less electrical ⁵ CPL12/xy 1/2" coupling ⁵ CPL34/xy 3/4" coupling ⁵ CPL1/xy 1" coupling ⁵ NPL12/xy 1/2" threaded nipple ⁵ NPL34/xy 3/4" threaded nipple ⁵ NPL1/xy 1" threaded nipple ⁵ EHHxy Extra handhole ^{5,7} MAEX Match existing ⁸ USPOM United States point of manufacture ⁹ UL UL listed with label (Includes NEC compliant cover) NEC NEC 410.30 compliant gasketed handhole (Not UL Labeled) <u>Shipped separately (replacement kit available)</u> (blank) BLTC Bolt caps FBC Full base cover (spun aluminum) (blank) TC Top cap (with drill-mount poles) (blank) HHC Handhole cover	<u>Standard colors</u> DDBXD Dark bronze DWH White DBLXD Black DMB Medium bronze DNA Natural aluminum BA Brushed aluminum <u>Classic colors</u> DSS Sandstone DGC Charcoal gray DTG Tennis green DBR Bright red DSB Steel blue <u>Class 1 architectural anodized</u> ABL Black ADB Dark bronze ANA Natural <u>Architectural Colors and Special Finishes¹⁰</u> Duranodic Anodize, Paint over Duranodic Anodize, RAL Colors, Custom Colors and Extended Warranty Finishes available.

NOTES:

- Wall thickness will be signified with a "C", "E" or a "G" in nomenclature. "C" - 0.125 | "E" - 0.156 | "G" - 0.188.
- PT open top poles include top cap. When ordering tenon mounting and drill mounting for the same pole, follow this example: DM28/T20. The combination includes a required extra handhole.
- Refer to the fixture spec sheet for the correct drilling template pattern and orientation compatibility.
- Insert "1" or "2" to designate fixture size; e.g. DM19AST2.
- Specify location and orientation when ordering option.
For "x": Specify the height above the base of pole in feet or feet and inches; separate feet and inches with a "-".
Example: 5ft = 5 and 20ft 3in = 20-3
For "y": Specify orientation from handhole
(A,B,C,D) Refer to the Handhole Orientation diagram below.
Example: 1/2" coupling at 5' 8", orientation C = CPL12/5-8C
- Horizontal arm is 18" x 2-3/8" O.D. tenon standard with radius curve providing 12' rise. If ordering two horizontal arm at the same height, specify with HAxy. Example: HA20BD
- Combination of tenon-top and drill mount includes extra handhole.
- Must add original order number of existing pole(s).
- Use when mill certifications are required.
- Additional colors available; see www.lithonia.com/archcolors or Architectural Colors brochure (Form No. 794.3). Available by formal quote only, consult factory for details.



POLE-RSA

OUTDOOR: One Lithonia Way Conyers, GA 30012 Phone: 800-705-SERV (7378) www.lithonia.com

© 1994-2019 Acuity Brands Lighting, Inc. All rights reserved.

Rev. 06/11/19

RSA Round Straight Aluminum Poles

TECHNICAL INFORMATION — EPA (ft ²) with 1.3 gust									
Catalog number	Nominal mount ht. (ft)*	Pole shaft size (in x ft)	Wall thick (in)	EPA (ft ²) with 1.3 gust			Max. weight (lbs)	Bolt size (in. x in. x in.)	Approximate ship (lbs.)
				80 mph	90 mph	100 mph			
RSA 8 4C	8	4 x 8	0.125	11.2	8.6	6.8	125	3/4 x 18 x 3	22
RSA 8 4-5C	8	4-1/2 x 8	0.125	14.6	11.3	9.1	175	3/4 x 18 x 3	30
RSA 8 4-5G	8	4-1/2 x 8	0.188	21.8	17	13.7	225	3/4 x 18 x 3	38
RSA 10 4C	10	4 x 10	0.125	8.2	6.1	4.7	100	3/4 x 18 x 3	26
RSA 10 4-5C	10	4-1/2 x 10	0.125	10.6	8.1	6.5	133	3/4 x 18 x 3	34
RSA 10 4-5G	10	4-1/2 x 10	0.188	16.3	12.6	10.1	175	3/4 x 18 x 3	43
RSA 10 5C	10	5 x 10	0.125	13.6	10.6	8.5	150	3/4 x 18 x 3	36
RSA 12 4C	12	4 x 12	0.125	6	4.3	3.2	110	3/4 x 18 x 3	30
RSA 12 4-5C	12	4-1/2 x 12	0.125	8.1	6	4.8	80	3/4 x 18 x 3	38
RSA 12 4-5G	12	4-1/2 x 12	0.188	12.7	9.7	7.7	185	3/4 x 18 x 3	50
RSA 12 5C	12	5 x 12	0.125	10.3	8	6.3	150	3/4 x 18 x 3	36
RSA 12 5E	12	5 x 12	0.156	13.2	10.3	8.2	200	3/4 x 18 x 3	44
RSA 12 5G	12	5 x 12	0.188	16.2	12.6	10.1	225	3/4 x 18 x 3	53
RSA 14 4C	14	4 x 14	0.125	4.1	2.8	1.9	75	3/4 x 18 x 3	35
RSA 14 4-5C	14	4-1/2 x 14	0.125	5.8	4.2	3.3	60	3/4 x 18 x 3	39
RSA 14 4-5G	14	4-1/2 x 14	0.188	9.7	7.3	5.8	190	3/4 x 18 x 3	56
RSA 14 5C	14	5 x 14	0.125	7.8	6	4.7	100	3/4 x 18 x 3	42
RSA 14 5E	14	5 x 14	0.156	10.3	8	6.3	125	3/4 x 18 x 3	47
RSA 14 5G	14	5 x 14	0.188	12.8	9.9	7.9	150	3/4 x 18 x 3	56
RSA 16 4C	16	4 x 16	0.125	2.8	1.6	1	150	3/4 x 18 x 3	38
RSA 16 4-5C	16	4-1/2 x 16	0.125	3.3	2.2	1.6	100	3/4 x 18 x 3	46
RSA 16 4-5G	16	4-1/2 x 16	0.188	7.5	5.5	4.3	155	3/4 x 18 x 3	62
RSA 16 5C	16	5 x 16	0.125	5.9	4.4	3.4	175	3/4 x 18 x 3	46
RSA 16 5E	16	5 x 16	0.156	8	6.1	4.8	190	3/4 x 18 x 3	53
RSA 16 5G	16	5 x 16	0.188	10.1	7.8	6.1	200	3/4 x 18 x 3	60
RSA 16 6E	16	6 x 16	0.156	13.6	10.6	8.4	225	3/4 x 30 x 3	53
RSA 16 6G	16	6 x 16	0.188	16.8	13	10.4	245	3/4 x 30 x 3	78
RSA 18 5G	18	5 x 18	0.188	8	6.8	4.7	225	3/4 x 18 x 3	68
RSA 18 5C	18	5 x 18	0.125	4.3	3.1	2.4	150	3/4 x 18 x 3	48
RSA 18 5E	18	5 x 18	0.156	6.1	4.6	3.5	175	3/4 x 18 x 3	58
RSA 18 4-5G	18	4-1/2 x 18	0.188	5.7	4	3.1	123	3/4 x 18 x 3	68
RSA 18 6G	18	6 x 18	0.188	13.9	10.7	8.5	225	3/4 x 30 x 3	86
RSA 20 4-5G	20	4-1/2 x 20	0.188	4.3	2.9	2.1	95	3/4 x 18 x 3	74
RSA 20 5C	20	5 x 20	0.125	3	2.1	1.5	150	3/4 x 18 x 3	54
RSA 20 5E	20	5 x 20	0.156	4.7	3.4	2.6	150	3/4 x 18 x 3	68
RSA 20 5G	20	5 x 20	0.188	6.4	4.8	3.6	150	3/4 x 18 x 3	82
RSA 20 6E	20	6 x 20	0.156	9.3	7.1	5.5	175	3/4 x 30 x 3	95
RSA 20 6G	20	6 x 20	0.188	11.8	9.1	7.1	200	3/4 x 30 x 3	110
RSA 25 4-5G	25	4-1/2 x 25	0.188	1.3	--	--	100	3/4 x 18 x 3	89
RSA 25 6E	25	6 x 25	0.156	5.2	3.8	2.8	150	3/4 x 30 x 3	108
RSA 25 6G	25	6 x 25	0.188	7.1	5.3	4	150	3/4 x 30 x 3	128
RSA 30 6G	30	6 x 30	0.188	3.5	2.4	1.6	200	3/4 x 30 x 3	146

* TECHNICAL INFORMATION — EPA (ft²) with 1.3 gust. For 1/2 ft increments, add -6 to the pole height. Ex: 20-6 equals 20ft 6in.



POLE-RSA

OUTDOOR: One Lithonia Way Conyers, GA 30012 Phone: 800-705-SERV (7378) www.lithonia.com

© 1994-2019 Acuity Brands Lighting, Inc. All rights reserved.

Rev. 06/11/19

RSA Round Straight Aluminum Poles

BASE DETAIL

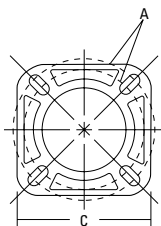
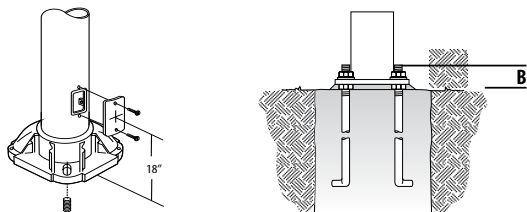

POLE DATA					
Shaft base size	Bolt circle A	Bolt projection B	Base square C	Template description	Anchor bolt description
4"	6.75" - 8.00"	3.25"	8.91"	ABTEMPLATE PJ50057	AB18-0
4.5"	7.06" - 8.62"	3.25"	9.26"	ABTEMPLATE PJ50040	AB18-0
5"	7.75" - 8.00"	3.25"	9.61"	ABTEMPLATE PJ50058	AB18-0
6"	9.00"-10.00"	3.50"	10.32"	ABTEMPLATE PJ50059	AB30-0

HANDHOLE ORIENTATION

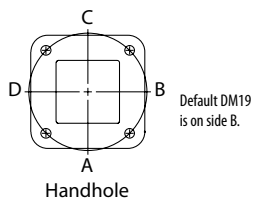

IMPORTANT INSTALLATION NOTES:

- Do not erect poles without having fixtures installed.
- Factory-supplied templates must be used when setting anchor bolts. Lithonia Lighting will not accept claim for incorrect anchorage placement due to failure to use factory template.
- If poles are stored outside, all protective wrapping must be removed immediately upon delivery to prevent finish damage.
- Lithonia Lighting is not responsible for the foundation design.



POLE-RSA

OUTDOOR: One Lithonia Way Conyers, GA 30012 Phone: 800-705-SERV (7378) www.lithonia.com

© 1994-2019 Acuity Brands Lighting, Inc. All rights reserved.

Rev. 06/11/19

DESCRIPTION

The Entri LED luminaire features a classic and stylish design with the added benefits of solid state lighting technology, offering outstanding uniformity and energy savings. Using Eaton's proprietary LED LightBAR™ technology and AccuLED Optics™ system, the Entri LED luminaire offers designers vast versatility in system design, function and performance. Use Entri LED for wall mount architectural lighting applications and egress lighting requirements. UL/cUL listed for use in wet locations.

Catalog #		Type
Project		
Comments		Date
Prepared by		

SPECIFICATION FEATURES

Construction

HOUSING: Heavy wall, one-piece, die-cast aluminum construction for precise tolerance control and repeatability in manufacturing. Integral extruded aluminum heat sink provides superior thermal heat transfer in +40°C ambient environments. **FACEPLATE / DOOR:** One-piece, die-cast aluminum construction. Captive, side hinged faceplate swings open via release of one flush mount die-cast aluminum latch on housing side panel. **GASKET:** One-piece molded silicone gasket mates perfectly between the door and housing for repeatable seal. **LENS:** Uplight lens is impact-resistant, 5/32" thick tempered frosted glass sealed to housing with continuous bead silicone gasket. Downlight lens is LED board integrated acrylic over-optics, each individually sealed for IP66 rating. **HARDWARE:** Stainless steel mounting screws and latch hardware allow access to electrical components for installation and servicing.

Optics

Choice of six patented, high-efficiency AccuLED Optic distributions. Optics are precisely designed to shape the light output, maximizing efficiency and application spacing. AccuLED Optic technology creates consistent distributions with the scalability to meet customized application requirements. Offered Standard in

4000K (+/- 275K) CCT and minimum 70 CRI. Optional 3000K CCT and 5000K CCT.

Electrical

LED drivers mount to die-cast aluminum back housing for optimal heat sinking, operation efficacy, and prolonged life. Standard drivers feature electronic universal voltage (120-277V 50/60Hz), 347V 60Hz or 480V 60Hz operation. 480V is compatible for use with 480V Wye systems only. Greater than 0.9 power factor, less than 20% harmonic distortion, and is suitable for operation in -40°C to 40°C ambient environments. All fixtures are shipped standard with 10kV/10kA common – and differential – mode surge protection. LightBARs feature and IP66 enclosure rating and maintain greater than 95% lumen maintenance at 60,000 hours per IESNA TM-21. Emergency egress options for -20°C ambient environments, occupancy sensor and dimming options available.

Mounting

JUNCTION BOX: Standard with zinc-plated, quick-mount junction box plate that mounts directly to 4" J-Box. LightBARs mount facing downward. Fixture slides over mounting plate and is secured with two stainless steel fasteners. Mounting plate features a one-piece EPDM gasket on back side of plate to firmly seal fixture to

wall surface, forbidding entry of moisture and particulates. Optional mounting arrangements utilize a die-cast mounting adaptor box to allow for LED battery pack, surface conduit and through branch wiring. The Entri LED luminaire is approved for mounting on combustible surfaces.

Finish

Housing is finished in five-stage super TGIC polyester powder coat paint, 2.5 mil nominal thickness for superior protection against fade and wear. LightBAR cover plates are standard white and may be specified to match finish of luminaire housing. Standard colors include black, bronze, grey, white, dark platinum and graphite metallic. RAL and custom color matches available. Consult Outdoor Architectural Colors brochure for a complete selection.

Warranty

Five-year warranty.



ENC/ENT/ENV ENTRI LED

1 - 2 LightBARs
Solid State LED

ARCHITECTURAL WALL
LUMINAIRE

DIMENSIONS

ENC (Round Clean)

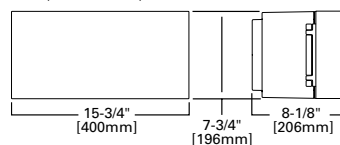

ENT (Triangle Reveals)

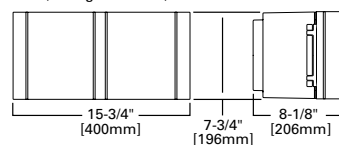

ENV (Round Reveals)

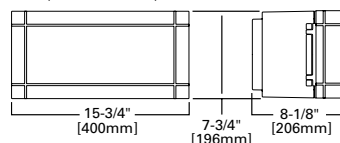

CONDUIT MOUNT / BATTERY BACK BOX

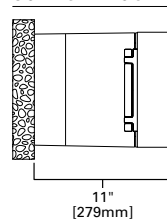

*www.designlights.org



CERTIFICATION DATA

UL/cUL Listed
ISO 9001
IP66 LightBARs
LM79 / LM80 Compliant
DesignLights Consortium® Qualified*

ENERGY DATA

Electronic LED Driver
>0.9 Power Factor
<20% Total Harmonic Distortion
120-277V/50 & 60Hz, 347V/60Hz, 480V/60Hz
-30°C Minimum Temperature
40°C Ambient Temperature Rating

SHIPPING DATA

Approximate Net Weight:
16 lbs. (7.3 kgs.)



TD514003EN
February 7, 2019 9:57 AM

CONTROL OPTIONS

0-10V

This fixture is offered standard with 0-10V dimming driver(s). The DIM option provides 0-10V dimming wire leads for use with a lighting control panel or other control method.

Dimming Occupancy Sensor (MS/DIM-LXX and OSB-LXX)

These sensors are factory installed in the luminaire housing. When the MS/DIM-LXX sensor option is selected, the occupancy sensor is connected to a dimming driver and the entire luminaire dims when there is no activity detected. When activity is detected, the luminaire returns to full light output. The MS/DIM sensor is factory preset to dim down to approximately 50 percent power with a time delay of five minutes. The OSB-LXX sensor is factory preset to turn the luminaire off after five minutes of no activity.

These occupancy sensors includes an integral photocell that can be activated with the FSIR-100 accessory for "dusk-to-dawn" control or daylight harvesting - the factory preset is OFF. The FSIR-100 is a wireless tool utilized for changing the dimming level, time delay, sensitivity and other parameters.

A variety of sensor lens are available to optimize the coverage pattern for mounting heights from 8'-40'.

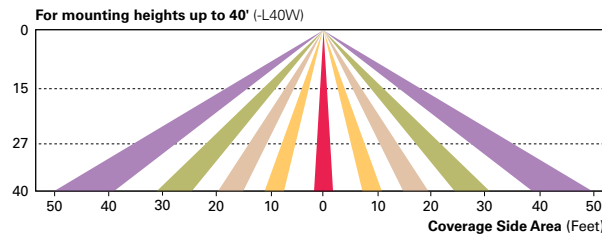
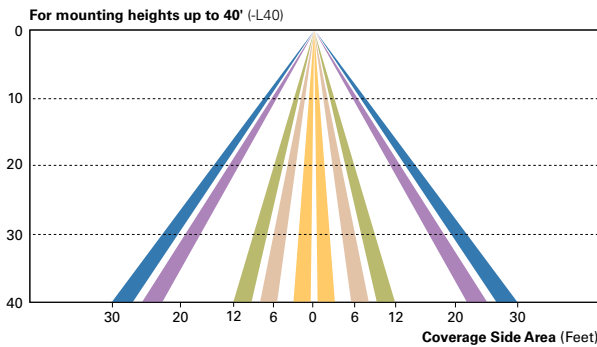
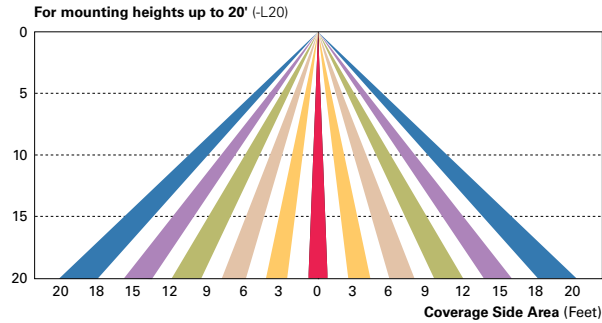
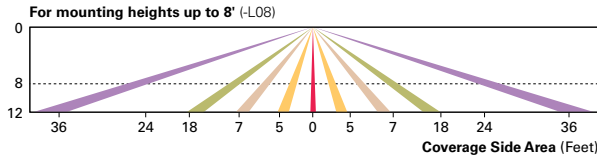

LumaWatt Pro Wireless Control and Monitoring System (LWR-LW and LWR-LN)

The LumaWatt Pro system is a peer-to-peer wireless network of luminaire-integral sensors for any sized project. Each sensor is capable of motion and photo sensing, metering power consumption and wireless communication. The end-user can securely create and manage sensor profiles with browser-based management software. The software will automatically broadcast to the sensors via wireless gateways for zone-based and individual luminaire control. The LumaWatt Pro software provides smart building solutions by utilizing the sensor to provide easy-to-use dashboard and analytic capabilities such as improved energy savings, traffic flow analysis, building management software integration and more.

For additional details, refer to the LumaWatt Pro product guides.

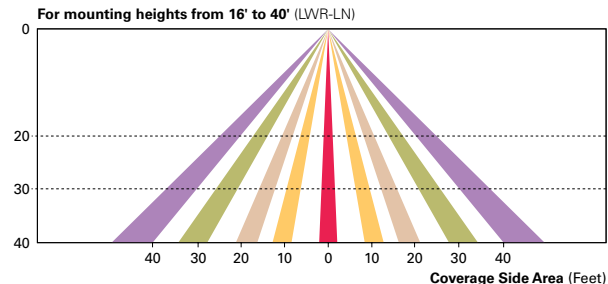
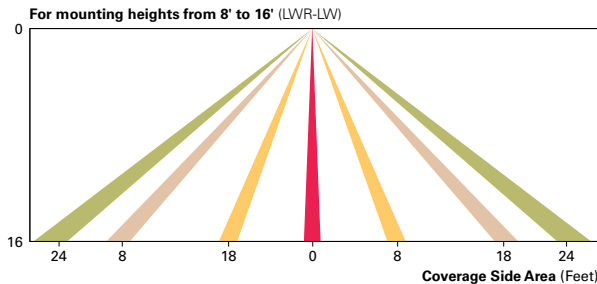

Eaton
1121 Highway 74 South
Peachtree City, GA 30269
P: 770-486-4800
www.eaton.com/lighting

Specifications and dimensions subject to change without notice.

TD514003EN
February 7, 2019 9:57 AM

POWER AND LUMENS BY BAR COUNT

Number of LightBARs		E01	E02	F01	F02	
		21 LED LightBAR		7 LED LightBAR		
Drive Current		350mA			1A	
Power (Watts)	120-277V	25W	47W	26W	50W	
Current (A)	120V	0.22	0.40	0.22	0.42	
	277V	0.10	0.18	0.10	0.19	
Power (Watts)	347V or 480V	31W	52W	32W	55W	
Current (A)	347V	0.11	0.16	0.11	0.17	
	480V	0.16	0.18	0.16	0.18	
Optics						
BL2	Lumens	2,738	5,476	2,260	4,521	
	Bug Rating	B1-U0-G1	B1-U0-G1	B1-U0-G1	B1-U0-G1	
BL3	Lumens	2,702	5,405	2,231	4,462	
	Bug Rating	B1-U0-G1	B1-U0-G2	B1-U0-G1	B1-U0-G1	
BL4	Lumens	2,613	5,225	2,157	4,313	
	Bug Rating	B1-U0-G1	B1-U0-G2	B1-U0-G1	B1-U0-G1	
GZW	Lumens	2,785	5,570	2,299	4,598	
	Bug Rating	B2-U0-G2	B3-U0-G3	B1-U0-G1	B2-U0-G2	
SLR/SL	Lumens	2,435	4,869	2,010	4,020	
	Bug Rating	B1-U0-G1	B1-U0-G2	B1-U0-G1	B1-U0-G2	

LUMEN MAINTENANCE

Ambient Temperature	25,000 Hours*	50,000 Hours*	60,000 Hours*	100,000 Hours	Theoretical L70 (Hours)
25°C	> 99%	> 97%	> 96%	> 93%	> 450,000
40°C	> 98%	> 97%	> 96%	> 92%	> 425,000
50°C	> 97%	> 96%	> 95%	> 91%	> 400,000

* Per IESNA TM-21 data.

LUMEN MULTIPLIER

Ambient Temperature	Lumen Multiplier
10°C	1.02
15°C	1.01
25°C	1.00
40°C	0.99

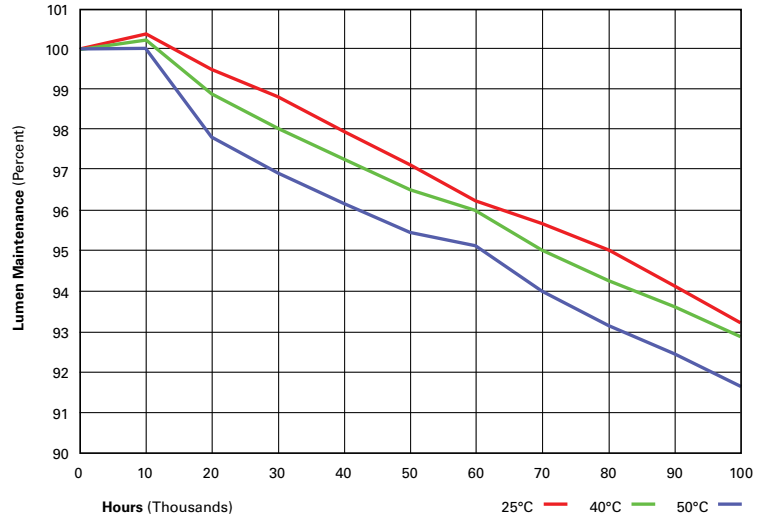

ORDERING INFORMATION

Sample Number: ENC-E02-LED-E1-BL3-GM

Product Family	Number of LightBARs ¹	Lamp Type	Voltage	Distribution	Color ²
ENC=Entri Round Clean ENT=Entri Triangle Reveals ENV=Entri Round Reveals	E01=(1) 21 LED LightBAR E02=(2) 21 LED LightBARs F01=(1) 7 LED LightBAR F02=(2) 7 LED LightBARs	LED=Solid State Light Emitting Diodes	E1=Electronic (120-277V) 347=347V 480=480V ²	BL2=Type II w/Back Light Control BL3=Type III w/Back Light Control BL4=Type IV w/Back Light Control GZW=Wall Grazer Wide SLL=90° Spill Light Eliminator Left SLR=90° Spill Light Eliminator Right	AP=Grey BZ=Bronze BK=Black DP=Dark Platinum GM=Graphite Metallic WH=White
Options (Add as Suffix)			Accessories (Order Separately) ¹⁴		
ULG=Uplight Glow (For Uplight Only) ⁴ PC=Button Type Photocontrol (120, 208, 240 or 277V. Must Specify Voltage) ⁵ WG=Wire Guard TP=Tamper Resistant Hardware LCF=LightBAR Cover Plate Matches Housing Finish 7030=70 CRI / 3000K CCT ⁶ 7050=70 CRI / 5000K CCT ⁶ 8030=80 CRI / 3000K CCT ⁶ OSB-LXX=Occupancy Sensor with Back Box (Specify 120V or 277V) ^{7,8} BBB=Battery Pack with Back Box (Specify 120V or 277V) ⁹ CWB=Cold Weather Battery Pack with Back Box (Specify 120V or 277V) ¹⁰ DIM=0-10V Dimming Driver LWR-LW=LumaWatt Pro Wireless Sensor, Wide Lens for 8' - 16' Mounting Height ^{11,13} LWR-LN=LumaWatt Pro Wireless Sensor, Narrow Lens for 16' - 40' Mounting Height ^{11,13} MS/DIM-LXX= Programmable Photo/Motion Sensor ^{8,12,13}			VA2001-XX=Thru-Way Conduit Box VA6172=Wire Guard VA6173=Tamper-Resistant Driver Bit MA1253=10kV Circuit Module Replacement FSIR-100=Wireless Configuration Tool for occupancy sensor ¹²		

NOTES:

- Standard 4000K CCT and greater than 70 CRI. LightBARs for downlight use only.
- Only for use with 480V Wye systems. Per NEC, not for use with ungrounded systems, impedance grounded systems or corner grounded systems (commonly known as Three Phase Three Wire Delta, Three Phase High Leg Delta and Three Phase Corner Grounded Delta systems)
- Custom and RAL color matching available upon request. Consult your lighting representative at Eaton for more information.
- Not available with LWR-XX or MS/DIM-LXX.
- Not available with ULG option.
- Extended lead times apply.
- Available with E02 or F02, only one bar on street side will be wired to sensor. Time delay factory setting 15-minutes. When ordered with PC option, both bars are connected to photocontrol as primary switching means. Standard sensor lens covers 8' mounting height, 360° coverage, maximum 48" diameter. Not available in all configurations or with BBB or CWB options.
- Replace 'XX' with mounting height in feet for proper lens selection, L08, L20 and L40 are available options.
- Specify 120V or 277V. LED standard integral battery pack is rated for minimum operating temperature 32°F (0°C). Operates one bar for 90-minutes. Not available in all configurations or with OSB option. Consult factory.
- Specify 120V or 277V. LED cold weather integral battery pack is rated for minimum operating temperature -4°F (-20°C). Operates one bar for 90-minutes. Not available in all configurations or with OSB option. Consult factory.
- LumaWatt Pro wireless sensors are factory installed only, order with OSB backbox, requiring network components LWP-EM-1, LWP-GW-1, LWP-PoE8 in appropriate quantities. See www.eaton.com/lighting for LumaWatt Pro application information.
- The FSIR-100 configuration tool enables adjustment of parameters including high and low modes, sensitivity, time delay, cutoff and more. Consult your lighting representative at Eaton for more information.
- Includes integral photocell.
- Replace XX with color suffix.



Eaton
1121 Highway 74 South
Peachtree City, GA 30269
P: 770-486-4800
www.eaton.com/lighting

Specifications and dimensions subject to change without notice.

TD514003EN
February 7, 2019 9:57 AM

BeveLED® 2.2 Basic

4.5" Round Downlight - B4RD-G1



Universal and Field Convertible - Trim | Trimless | Millwork



usailighting.com/beveledbasic

Meet the new and improved BeveLED Basic, upgraded with even more efficient, perfectly consistent classic white LED light engines and our field convertible trims that allow for easy on-site changes from trimmed to trimless to millwork – all in a budget-conscious product with the same below ceiling appearance as our extremely versatile BeveLED 2.2 product line.

FEATURES

- Field Flexibility between trimmed, trimless and millwork
- Dry/damp/wet location rated for bathrooms and showers, including trimless and millwork
- 1% dimming standard + more dimming options
- Clear overspray protector for installation convenience

COMPANION FAMILY PRODUCTS



Adjustable - B4RA-G1
usailighting.com/B4RA-G1



Wall Wash - B4RW-G1
usailighting.com/B4RW-G1

DOWNLIGHT PERFORMANCE DATA

DELIVERED* PERFORMANCE:	Classic White							
	9W		12W		16W		24W	
Color Rendering Index:	80+	90+	80+	90+	80+	90+	80+	90+
Source Lumens:	900	725	1275	1050	1775	1450	2650	2175
Lumens Per Watt:	79	65	85	69	85	69	89	73
Delivered Lumens:	700	575	1025	825	1425	1175	2125	1750
EM Mode Output:	550 Delivered Lumens (nominal)							

*Based on 3000K. Performance varies for each specific beamspread and color temperature. See IES files for exact values at usailighting.com.

CORRELATED COLOR TEMPERATURE MULTIPLIER

CORRELATED COLOR TEMPERATURE MULTIPLIER	Classic White							
	2700K		3000K		3500K		4000K	
Color Rendering Index:	80+	90+	80+	90+	80+	90+	80+	90+
Multiplier for Lumen Output:	0.94	0.82	1.00	0.82	1.00	.88	1.00	0.94

Page 1

USAI LIGHTING COLLABORATORY

13 Crosby Street
New York, NY 10013
845-234-4090
showroom@usailighting.com

USAI LIGHTING HEADQUARTERS

1126 River Road
New Windsor, NY 12553
T: 845-565-8500
info@usailighting.com

© 2019, USAI, LLC. All rights reserved.
All designs protected by copyright.
Covered by US Patents: 9,671,091 and 7,832,889.
Patents pending. USAI, BeveLED and Classic White are registered trademarks of USAI, LLC.
Revised 04/30/2020

HOW TO SPECIFY

BeveLED® 2.2 Basic

4.5" Round Downlight - B4RD-G1



Specify fixture part number. (All boxes must be filled in to correctly order)

B4RD										
BeveLED Trim Style	Wattage Options	LED Color Options	Beam Options	Lens Options	Bevel Trim Finish Options	*Flange/Millwork Collar Finish	Housing Options	Voltage Options <i>Select one</i>	Dimming Driver Options	Accessories (Optional)*
F Trimmed with Flange (use with all materials) L Trimless Spackle-in (use with sheetrock and plaster only) M Millwork Knife-Edge (use with wood and stone)	Classic White Light 09G1 9W LED 12G1 12W LED 16G1 16W LED 24G1 24W LED			S Solite (provided standard) BF Borosilicate Frosted	WH White	WH White	NCSM New Construction Narrow Width NC New Construction NCCP Chicago Plenum NCIC Insulation Contact Rated / Airtight (1)	UNV 120V-277V	For use with Universal Voltage 120V - 277V No Additional Charge D6E EldoLED 0-10V, 1% (provided standard) D6F EldoLED 0-10V, 1% D4E Lutron 5 ECO, 5% (1) D4H Lutron H ECO, 1% Fade (1) D6A EldoLED 0-10V, 0.1% D6B EldoLED 0-10V, 0.1% D7 EldoLED DALI, 0.1% D18 Moons DMX, 0.1%	CB27 27" C-Channel Bars CB52 52" C-Channel Bars EM Emergency Battery (2) EMW Emergency Battery Wet Location (3) *Residential grade nailer bars provided standard
	25 25° beam 50 50° beam 90 90° beam	SC Conduit Silver GR Grey BL Black BZ Bronze PR Primer Finish AC Clear Matte Anodized	SC Conduit Silver GR Grey BL Black BZ Bronze PR Primer Finish AC Clear Matte Anodized		AB Piano Gloss Black WH White GR Grey BL Black	120V				
					RAL Custom Color Specify RAL #	RAL Custom Color Specify RAL # *Leave blank for Trimless				

Notes: 1 Not available with 9W.
 2 For NC and NCSM housings only. NCSM housing requires above ceiling access.
 3. This is a gasketed remote test switch available with NCSM housings only. Above ceiling access required.

TRIM FINISH OPTIONS



Custom colors and primer finish also available

USAI LIGHTING COLLABORATORY
 13 Crosby Street
 New York, NY 10013
 845-234-4090
 showroom@usailighting.com

USAI LIGHTING HEADQUARTERS
 1126 River Road
 New Windsor, NY 12553
 T: 845-565-8500
 info@usailighting.com

© 2019, USAI, LLC. All rights reserved.
 All designs protected by copyright.
 Covered by US Patents: 9,671,091 and 7,832,889.
 Patents pending. USAI, BeveLED and Classic White are registered trademarks of USAI, LLC.
 Revised 04/30/2020

BeveLED® 2.2 Basic 4.5" Round Downlight - B4RD-G1



Trimmed - B4RDF-G1

TRIM DETAILS

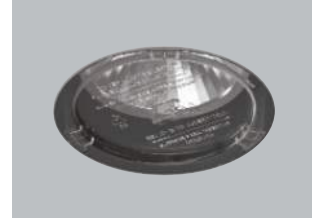
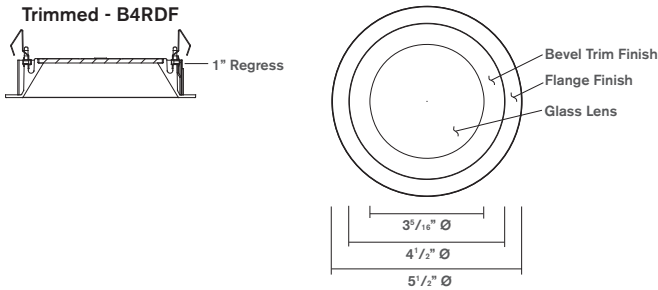

Clear acrylic overspray protector provided standard with every housing to keep out dust and contaminants during construction. Allows for use as work light.

HOUSING OPTIONS

New Construction Narrow Width - NCSM NCSM with Emergency Battery*

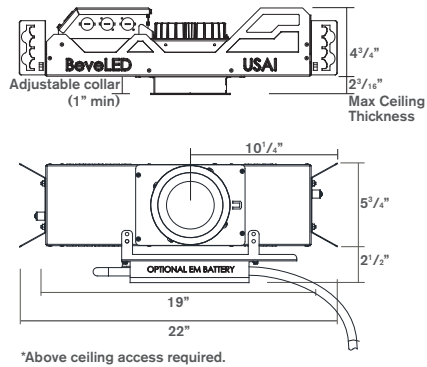

New Construction - NC Insulation-Contact Rated - NCIC Chicago Plenum Rated - NCCP NC with Emergency Battery

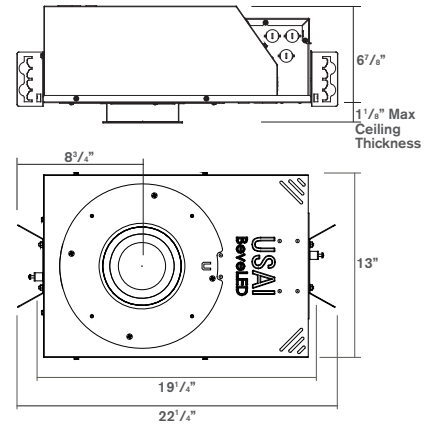

BeveLED® 2.2 Basic 4.5" Round Downlight - B4RD-G1



Trimless - B4RDL-G1

TRIM DETAILS

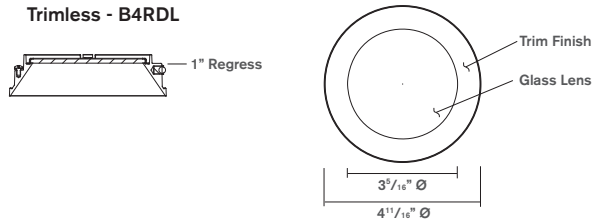

Clear acrylic overspray protector provided standard with every housing to keep out dust and contaminants during construction. Allows for use as work light.

HOUSING OPTIONS

New Construction Narrow Width - NCSM NCSM with Emergency Battery*

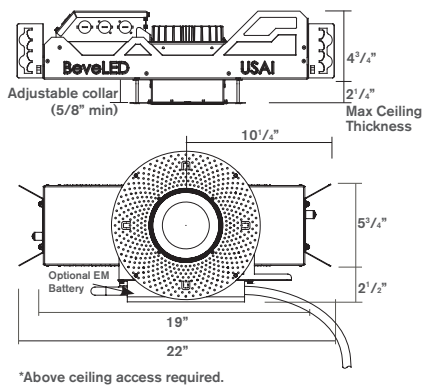

New Construction - NC Insulation-Contact Rated - NCIC Chicago Plenum Rated - NCCP NC with Emergency Battery

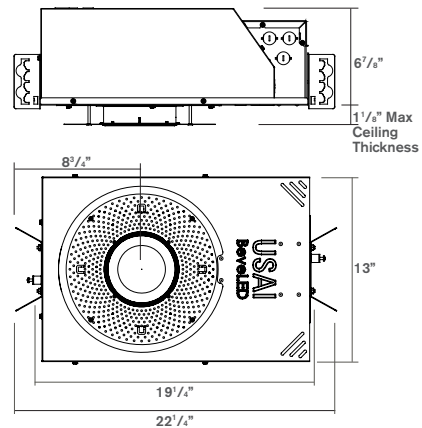

BeveLED® 2.2 Basic 4.5" Round Downlight - B4RD-G1



Millwork - B4RDM-G1

TRIM DETAILS

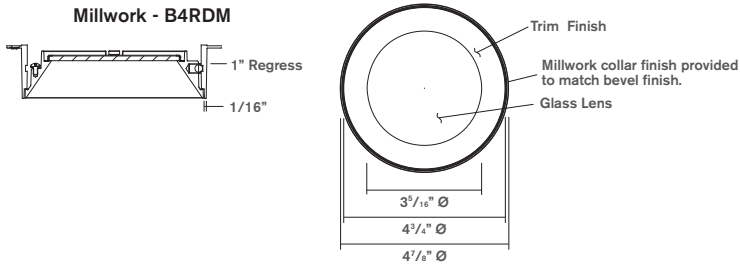

Clear acrylic overspray protector provided standard with every housing to keep out dust and contaminants during construction. Allows for use as work light.

HOUSING OPTIONS

New Construction Narrow Width - NCSM NCSM with Emergency Battery*

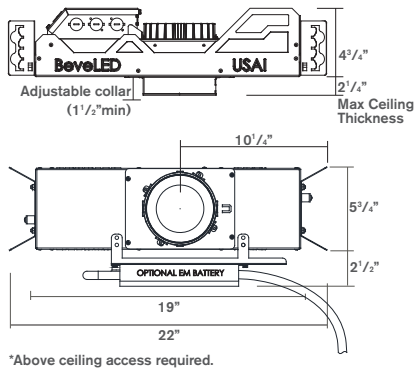

New Construction - NC Insulation-Contact Rated - NCIC Chicago Plenum Rated - NCCP NC with Emergency Battery

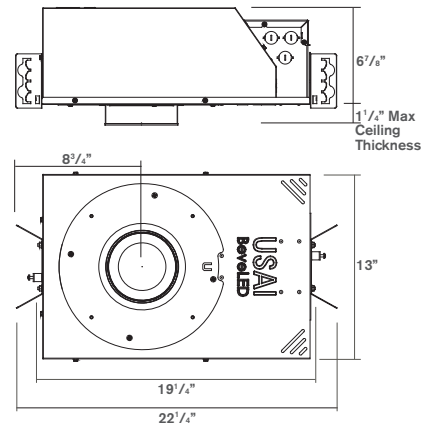

BeveLED[®] 2.2 Basic

4.5" Round Downlight - B4RD-G1

BEVELED BASIC SPECIFICATIONS

FIELD REPLACEABLE LED LIGHT ENGINE

is serviceable through the aperture without tools or with a Philips screwdriver. All USAI Lighting light engines feature industry-leading color consistency.

FIELD REPLACEABLE DRIVER

Unless otherwise specified, a 0-10V, 100%-1% solid state electronic constant current integral D6E dimming driver with a high power factor is provided standard and sources 2mA. All integral dimming drivers are located within the fixture housing and are serviceable from below the ceiling through the aperture. Some on-time delay may be experienced depending on control system used. All dimming drivers comply with IEEE C62.41 surge protection.

EMERGENCY BATTERY

IOTA emergency battery provides backup power for 90 minutes. NC EM fixtures are provided with an integral emergency battery with integral test switch and can be serviced through the aperture from below the ceiling plane. NCSM EM fixtures are provided with an integral emergency battery with a remote test switch, which comes with a 24" lead length for location of the test switch. Remote EM test switch is dry/damp only; select EMW emergency option for a wet location-rated EM test switch. NCSM EM fixtures require above ceiling access for service of the EM pack. Fixtures that have no USAI EM option may be connected to an inverter (by others) for emergency lighting.

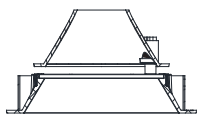

Integral Emergency Test Switch included with NC housing

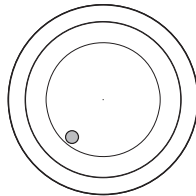

Remote Emergency Test Switch included with NCSM housing (above ceiling access required).

HOUSING

All BeveLED Basic fixtures are field-flexible which allows for field changes from trimless or millwork to trimmed with a simple components change with parts from USAI. Housings are fabricated of 20 ga. steel construction with thru wire J-box, 4 in 4 out at min. 90°C, #12 AWG thru branch circuit wiring, except for NCSM which is fabricated of 18 ga. steel. NCIC housing for use with 9W, 12W, and 16W light engines only is rated for direct contact with spray foam insulation of R-42 or less.

MOUNTING

B4RDF overlap flange fixtures are designed for use in sheetrock, acoustical ceiling tile, and many other ceiling materials. B4RDL trimless fixtures are provided with a spackle collar and are designed for use in sheetrock/mud-in ceiling applications. B4RDM millwork fixtures are provided with a millwork collar in finish to match trim finish specified and are designed for use in wood/millwork, stone and tile construction applications. Butterfly brackets and residential grade adjustable nailer bars extendible from 14" to 24" centers with integral nails are provided standard for attachment to building structure. C-channel bars are optionally available for acoustical ceiling applications.



Residential-grade nailer bars provided standard.

FIXTURE WEIGHT

NC, NCIC, and NCCP housings weigh 16 lbs. NCSM housing weighs 10 lbs., NCSM with EM weighs 16.5 lbs, and NC housing with EM weighs 24.5 lbs.

WARRANTY

Based on IESNA LM80-2008, BeveLED has a 50,000 hour rated life at 70% lumen maintenance (L70). USAI Lighting Warranty covers replacement parts for 5 years from date of shipment. Ambient temperatures at fixture location should not exceed 40°C during normal operation.

CEILING CUT OUT

B4RDF Trimmed with Overlap Flange: 5-1/16" Ø
 B4RDL Trimless Spackle-in: 5-1/2" Ø
 B4RDM Millwork Knife-edge: 4-15/16" Ø

LISTINGS

Dry/Damp/Wet location. AC and AB trim finishes are dry/damp only. Remote EM test switch is dry/damp only. Select EMW option for wet location remote test switch. UL2043 rated for use in air handling plenums. NRTL/CSA-US tested to UL standards. IBEW union made.



NOTES

- Use of pressure washer voids warranty

PHOTOMETRICS

Consult factory or website for IES files. Tested in accordance with IESNA LM79.

USAI LIGHTING COLLABORATORY

13 Crosby Street
 New York, NY 10013
 845-234-4090
 showroom@usailighting.com

USAI LIGHTING HEADQUARTERS

1126 River Road
 New Windsor, NY 12553
 T: 845-565-8500
 info@usailighting.com

DIMMING DRIVER WIRING SCHEMES:

NOTES:

Wiring diagrams are examples of typical installations intended to illustrate the number of wires that must be run to fixture. These diagrams are not intended to specify all equipment necessary for a given dimming circuit. Refer to specific dimmer manufacturer's documentation for details.

**IMPORTANT SAFETY INSTRUCTIONS
- SAVE THESE INSTRUCTIONS**

1. Keep these instructions in a safe place for future reference.
2. Only qualified electricians in accordance to local codes should install these fixtures.
3. De-energize the electrical circuit at the circuit breaker prior to installation process or servicing.
4. Make sure all connections are in accordance with the National Electrical Code and any local regulations.
5. Cap any wires not used separately (not together).

D3 / DIML3 LED: Lutron Hi-Lume A-Series 2 Wire Fwd Phase (with neutral) / LED Dimming Driver Wiring (Dims down to 1%) 120V

D3 / DIML3 Dimmer Compatibility Chart					
Manufacturer	Product	Part Number	Dimmed Light Output Range	Qty Fixtures Per Dimmer*	
				Fixture Wattage	
120V Only					
				39W and Less	40W - 80W
ETC	Sensor+ Cabinet	ELV10	100% - 1%	1 - 26	1 - 13
ETC	Unison DRd Cabinet	ELV10	100% - 1%	1 - 26	1 - 13
Lutron	Maestro Wireless® 600W dimmer	MRF2-6ND-120-	100% - 1%	1 - 8	1 - 4
Lutron	Maestro Wireless® 1000W dimmer	MRF2-10ND-120-	100% - 1%	1 - 13	1 - 6
Lutron	HomeWorks® QS adaptive dimmer	HQRD-6NA-	100% - 1%	1 - 8	1 - 4
Lutron	HomeWorks® QS 600W dimmer	HQRD-6ND-	100% - 1%	1 - 8	1 - 4
Lutron	HomeWorks® QS 1000 W dimmer	HQRD-10ND-	100% - 1%	1 - 13	1 - 6
Lutron	Caseta Wireless® Pro 1000W dimmer	PD-10NXD-	100% - 1%	1 - 13	1 - 6
Lutron	Stanza® dimmer	SZ-6ND-	100% - 1%	1 - 8	1 - 4
Lutron	RadioRA® 2 adaptive dimmer	RRD-6NA-	100% - 1%	1 - 8	1 - 4
Lutron	RadioRA® 2 1000 W dimmer	RRD-10ND-	100% - 1%	1 - 6	1 - 3
Lutron	myRoom DIN power module	MQSE-4A1-D	100% - 1%	1 - 6	1 - 3
Lutron	HomeWorks® QS wallbox power module	HQRJ-WPM-6D-120-	100% - 1%	1 - 26	1 - 13
Lutron	Homeworks® DIN power module	LQSE-4A1-D	100% - 1%	1 - 6	1 - 3
Lutron	HomeWorks® wallbox power module	HWI-WPM-6D-120	100% - 1%	1 - 26	1 - 13
Lutron	GRAFIK Eye® QS control unit	QSGR-, QSGRJ-	100% - 1%	1 - 26	1 - 13
Lutron	GRAFIK Eye® 3000 control unit	GRX-3100-, GRX-3500-	100% - 1%	1 - 26	1 - 13
Lutron	RPM-4U module	HW-RPM-4U-120, LP-RPM-4U-120	100% - 1%	1 - 26	1 - 13
Lutron	RPM-4A module	HW-RPM-4A-120, LP-RPM-4A-120	100% - 1%	1 - 26	1 - 13
Lutron	GP dimming panels	Various	100% - 1%	1 - 26	1 - 13
Lutron	Ariadni CL 250W dimmer	AYCL-253P-	100%-1%	1 - 8	1 - 4
Lutron	Diva CL 250W dimmer	DVCL-253P-, DVSCCL-253P-	100%-1%	1 - 8	1 - 4
Lutron	Grafik T CL or RF CL dimmer	GT-250M-, GTJ-250M-	100%-1%	1 - 8	1 - 4
Lutron	Nova T CL 250W dimmer	NTCL-250-	100%-1%	1 - 10	1 - 5

* NOTE: Refer to dimmer manufacturer's documentation for installation instructions and circuit details.

**D3 / DIML3
2 WIRE PHASE DIMMING**

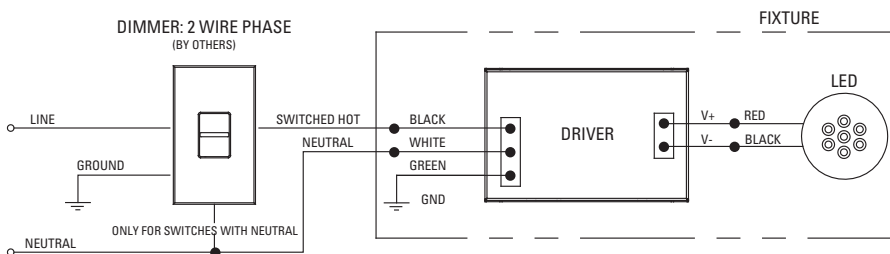

DIMMING DRIVER WIRING SCHEMES:

NOTES:

Wiring diagrams are examples of typical installations intended to illustrate the number of wires that must be run to fixture. These diagrams are not intended to specify all equipment necessary for a given dimming circuit. Refer to specific dimmer manufacturer's documentation for details.

**IMPORTANT SAFETY INSTRUCTIONS
- SAVE THESE INSTRUCTIONS**

1. Keep these instructions in a safe place for future reference.
2. Only qualified electricians in accordance to local codes should install these fixtures.
3. De-energize the electrical circuit at the circuit breaker prior to installation process or servicing.
4. Make sure all connections are in accordance with the National Electrical Code and any local regulations.
5. Cap any wires not used separately (not together).

D4E / DIML4E LED: Lutron 5 Series EcoSystem LED Driver / LED Dimming Driver Wiring (Dims down to 5%)

D4E / DIML4E EcoSystem Dimmer Compatibility Chart					
Manufacturer	Product	Part Number	Dimmed Light Output Range	Qty Fixtures Per Control*	
				Fixture Wattage	
120V / 277V					
				39W and Less	40W - 80W
Lutron	PowPak dimming module	RMJ-ECO32-DV-B	100%-5%	1-32	1-16
Lutron	Energi Savr Node	QSN-1ECO-S, QSN-2ECO-S	100%-5%	1-64	1-32
Lutron	GRAFIK Eye QS (120V ONLY)	QSGRJ- E, QSGR- E	100%-5%	1-64	1-32
Lutron	Quantum	Various	100%-5%	1-64	1-32

* NOTE: Number of fixtures may be higher if wattage is less than maximum values shown. Refer to dimmer manufacturer's documentation for installation instructions and circuit details.

D4H / DIML4H LED: Lutron H Series EcoSystem LED Driver with Fade to Black (dims down to 1%)

D4H / DIML4H EcoSystem Dimmer Compatibility Chart					
Manufacturer	Product	Part Number	Dimmed Light Output Range	Qty Fixtures Per Control*	
				Fixture Wattage	
120V / 277V					
				39W and Less	40W - 80W
Lutron	PowPak dimming module	RMJ-ECO32-DV-B	100%-1%	1-32	1-16
Lutron	Energi Savr Node	QSN-1ECO-S, QSN-2ECO-S	100%-1%	1-64	1-32
Lutron	GRAFIK Eye QS (120V ONLY)	QSGRJ- E, QSGR- E	100%-1%	1-64	1-32
Lutron	Quantum	Various	100%-1%	1-64	1-32

* NOTE: Number of fixtures may be higher if wattage is less than maximum values shown. Refer to dimmer manufacturer's documentation for installation instructions and circuit details.

**D4E / DIML4E and D4H / DIML 4H
EcoSystem CONTROLS**

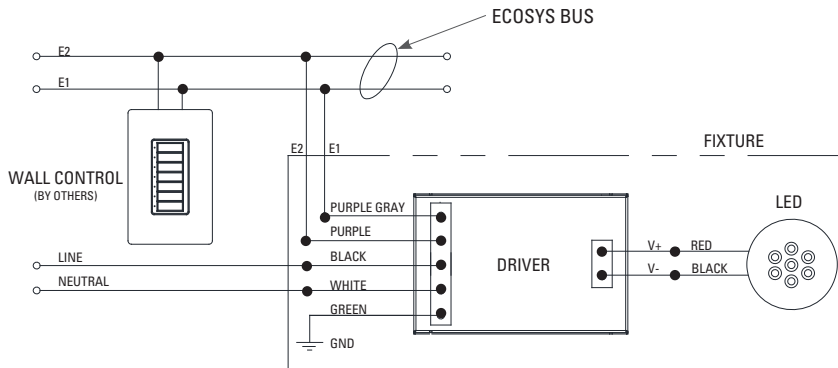

**IMPORTANT SAFETY INSTRUCTIONS
- SAVE THESE INSTRUCTIONS**

1. Keep these instructions in a safe place for future reference.
2. Only qualified electricians in accordance to local codes should install these fixtures.
3. De-energize the electrical circuit at the circuit breaker prior to installation process or servicing.
4. Make sure all connections are in accordance with the National Electrical Code and any local regulations.
5. Cap any wires not used separately (not together).

D6A / DIML6A and D6E / DIML6E LED Dimming Compatibility Table

D6A / DIML6A and D6E / DIML6E are linearly programmed dimming drivers for use with the dimming controls listed in the table below.
D6A / DIML6A = EldoLED SOLOdrive 0-10V control dims from 100% to 0.1%
D6E / DIML6E = EldoLED ECOdrive 0-10V control dims from 100% to 1%

D6A / DIML6A and D6E / DIML6E Dimmer Compatibility Chart					
Manufacturer	Product	Part Number	Dimmed Light Output Range		Qty Fixtures Per Dimmer*
			DIML6A	6E	
120V & 277V					
Lutron	Diva	DVTV/NFTV with PP-20	99%	0.1%	1%
Lutron	Nova T	NFTV with PP-20	99%	0.1%	1%
Lutron	Energi Savr Node	QSN-4T16-S	100%	0.1%	1%
Lutron	GP Dimming Panels	TVM2 Module	99%	0.1%	1%
Lutron	Interfaces	GRX-TVI w/ GRX3503	100%	0.1%	1%
Sensor Switch enlightened	nIO Control Unit	nIO EZ CU-3E-1R	100%	0.1%	1%

D6B / DIML6B and D6F / DIML6F LED Dimming Compatibility Table

D6B / DIML6B and D6F / DIML6F are logarithmic-programmed dimming drivers for use with the dimming controls listed in the table below.
D6B / DIML6B = EldoLED SOLOdrive 0-10V control dims from 100% to 0.1% D6F / DIML6F = EldoLED ECOdrive 0-10V control dims from 100% to 1%

D6B / DIML6B and D6F / DIML6F Dimmer Compatibility Chart					
Manufacturer	Product	Part Number	Dimmed Light Output Range		Qty Fixtures Per Dimmer*
			DIML6B	6F	
120V & 277V					
Bush-Jaeger	Electronic potentiometer	2112U-101	100%	0.1%	1%
Jung	Electronic potentiometer	240-10	100%	0.1%	1%
Leviton	Iluma Tech dimmer	IP710-DLX	100%	0.1%	1%
Lightolier (Philips)	Momentum (120V ONLY)	ZP600FAM120	100%	0.1%	1%
Merten	Electronic potentiometer	5729	100%	0.1%	1%
Pass & Seymour	Titan	CD4FB-W	100%	0.1%	1%
Watt Stopper	Miro	DCLV1	100%	0.1%	1%
Synergy	Wallbox Dimmers	ISD BC	100%	0.1%	1%
ABB	i-bus	SD/S 2.16.1	100%	0.1%	1%
Crestron	Modules	GLX-DIMFLV8, GLXP-DIMFLV8	100%	0.1%	1%
Crestron	Green Light	GLPAC-DIMFLV4-, GLPAC-DIMFLV8-	100%	0.1%	1%
Crestron	Green Light Power Pack	GLPP-DIMFLVEX-PM, GLPP-1DIMFLV2EX-PM, GLPP-1DIMFLV3EX-PM	100%	0.1%	1%
Crestron	DIN Rail Analog Output Module	DIN-A08	100%	0.1%	1%
Crestron	DIN Rail 0-10V Fluorescent Dimmer	DIN-4DIMFLV4	100%	0.1%	1%
Crestron	iLux 0-10V Dimmer Expansion Module	CLS-EXP-DIMFLV	100%	0.1%	1%
enlighted	Control Unit	CU-3E-1R	100%	0.1%	1%

DIMMING DRIVER WIRING SCHEMES:

NOTES: Wiring diagrams are examples of typical installations intended to illustrate the number of wires that must be run to fixture. These diagrams are not intended to specify all equipment necessary for a given dimming circuit. Refer to specific dimmer manufacturer's documentation for details.

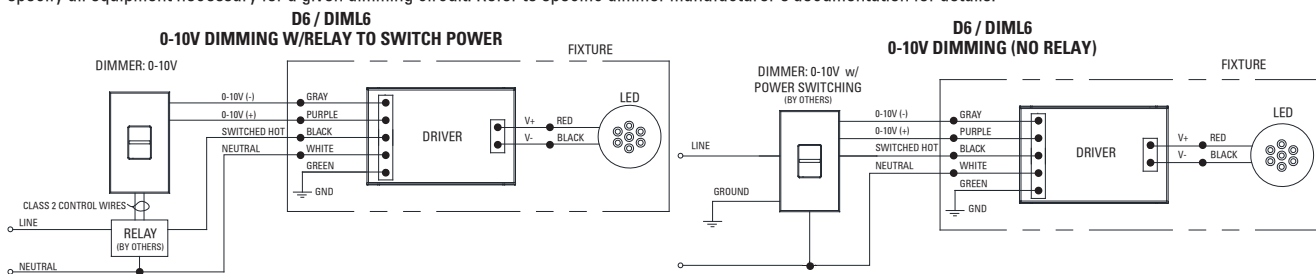

DIMMING DRIVER WIRING SCHEMES:

NOTES:

Wiring diagrams are examples of typical installations intended to illustrate the number of wires that must be run to fixture. These diagrams are not intended to specify all equipment necessary for a given dimming circuit. Refer to specific dimmer manufacturer's documentation for details.

**IMPORTANT SAFETY INSTRUCTIONS
- SAVE THESE INSTRUCTIONS**

1. Keep these instructions in a safe place for future reference.
2. Only qualified electricians in accordance to local codes should install these fixtures.
3. De-energize the electrical circuit at the circuit breaker prior to installation process or servicing.
4. Make sure all connections are in accordance with the National Electrical Code and any local regulations.
5. Cap any wires not used separately (not together).

D7 / DIML7 and D7E Dimming Driver Wiring

D7 / DIML7 and D7E are linearly programmed dimming drivers.

D7 / DIML7 = EldoLED SOLOdrive DALI control dims from 100% to 0.1%

D7E = EldoLED ECOdrive DALI control dims from 100% to 1%

**D7 / DIML7 / D7E
DALI CONTROLS**

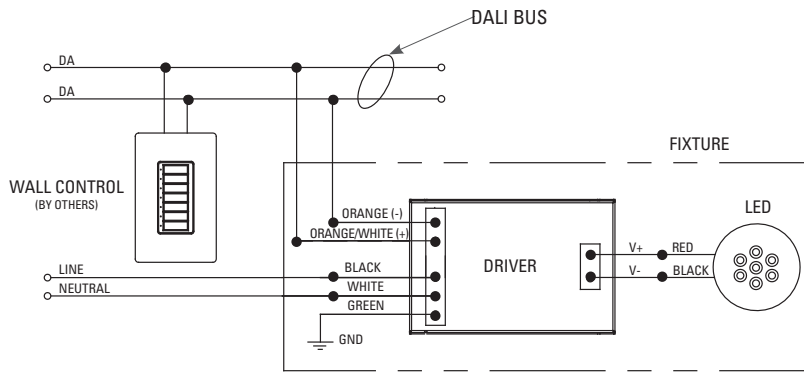

DIMMING DRIVER WIRING SCHEMES:

NOTES:

Wiring diagrams are examples of typical installations intended to illustrate the number of wires that must be run to fixture. These diagrams are not intended to specify all equipment necessary for a given dimming circuit. Refer to specific dimmer manufacturer's documentation for details.

**IMPORTANT SAFETY INSTRUCTIONS
- SAVE THESE INSTRUCTIONS**

1. Keep these instructions in a safe place for future reference.
2. Only qualified electricians in accordance to local codes should install these fixtures.
3. De-energize the electrical circuit at the circuit breaker prior to installation process or servicing.
4. Make sure all connections are in accordance with the National Electrical Code and any local regulations.
5. Cap any wires not used separately (not together).

D18 Dimming Driver Wiring

D18 are programmed dimming drivers.
D18 Moons DMX control dims from 100% to 1%

**DMX BUS -
SHIELDED DATA CABLE**

The data cable used must meet the following requirements:

- type: shielded, 2-conductor twisted pair
- maximum capacitance between conductors: 30 pF/ft
- maximum capacitance between conductor and shield: 55 pF/ft
- maximum resistance: 0.02 ohms/ft
- normal impedance: 100-140 ohms
- conductive core: 24 AWG is recommended

If 3-wire data cables are preferred, we suggest a Belden 9841 or equivalent cable which meets the specifications for EIA RS-485 applications. Do not use standard microphone cables: they cannot transmit DMX512 data reliably over long distances. NOTE: DMX link termination device, provided through Dip Switch on connection board, should be used on last fixture in line on a circuit to avoid signal loss.

**D18
DMX CONTROLS**

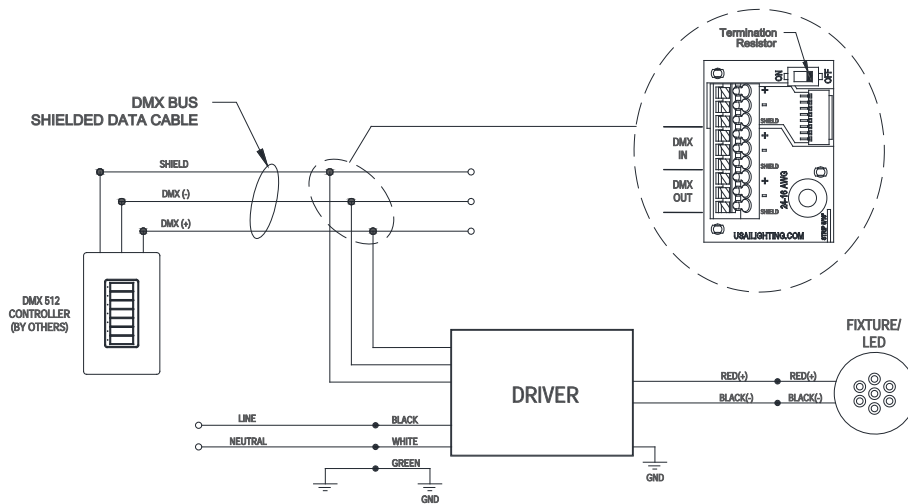

DIMMING DRIVER WIRING SCHEMES:

NOTES:

Wiring diagrams are examples of typical installations intended to illustrate the number of wires that must be run to fixture. These diagrams are not intended to specify all equipment necessary for a given dimming circuit. Refer to specific dimmer manufacturer's documentation for details.

**IMPORTANT SAFETY INSTRUCTIONS
- SAVE THESE INSTRUCTIONS**

1. Keep these instructions in a safe place for future reference.
2. Only qualified electricians in accordance to local codes should install these fixtures.
3. De-energize the electrical circuit at the circuit breaker prior to installation process or servicing.
4. Make sure all connections are in accordance with the National Electrical Code and any local regulations.
5. Cap any wires not used separately (not together).

**D19 / DIML19 LED: Hatch XTC series or equivalent - Forward and Reverse Phase Dimming Driver.
Dims down to 1% contingent upon dimmer specification and load. 120V only.**

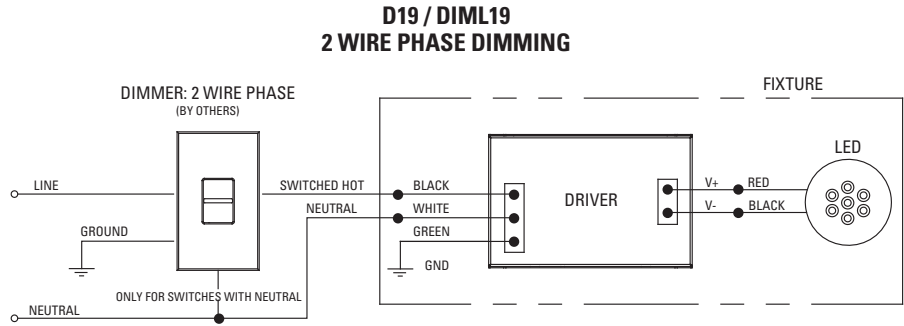

D19 / DIML19 Dimmer Compatibility Chart

120V ONLY		
Forward Phase / TRIAC Dimming		
Manufacturer	Product	Qty Fixtures Per Dimmer
Leviton	IPL06-10Z	Use fixture wattage per fixture specification sheet to determine number of fixtures per dimmer. Max number of fixtures is limited by dimmer load rating.
	6613-xxx	
Lutron	S-600P	Use fixture wattage per fixture specification sheet to determine number of fixtures per dimmer. Max number of fixtures is limited by dimmer load rating.
	S-603P	
	DV-600P	
	DV-603P	
	DVSC-603P	
	CT-600P	
CT-603P		
120V ONLY		
Reverse Phase / ELV Dimming		
Manufacturer	Product	Qty Fixtures Per Dimmer
Leviton	6615	Use fixture wattage per fixture specification sheet to determine number of fixtures per dimmer. Max number of fixtures is limited by dimmer load rating.
	IPE04-xxx	
Lutron	NTELV-300	Use fixture wattage per fixture specification sheet to determine number of fixtures per dimmer. Max number of fixtures is limited by dimmer load rating.
	NTELV-600	
	SELV-300P	
	SELV-303P	
	DVELV-300P	
DVELV-303P		

FEATURES & SPECIFICATIONS

INTENDED USE — A general purpose and energy-efficient surface-mounted or suspended LED fixture, suitable for wet, damp and/or cold locations. For vapor-tight demanding environments where moisture or dust is a concern and where relatively low fixture mounting heights and wide fixture spacing are common. Typical applications include industrial facilities, parking garages, retail malls, multi-purpose rooms, garden centers, and food processing. **Certain airborne contaminants can diminish the integrity of acrylic and/or polycarbonate.** [Click here for Acrylic-Polycarbonate Compatibility table for suitable use.](#)

Certain airborne contaminants may adversely affect the functioning of LEDs and other electronic components, depending on various factors such as concentrations of the contaminants, ventilation, and temperature at the end-user location. [Click here for a list of substances that may not be suitable for interaction with LEDs and other electronic components.](#)

CONSTRUCTION — One-piece 5VA fiberglass housing with integral perimeter channel utilizing continuous poured-in-place NEMA 4X gasket. Approved as a wireway and for through wiring. Captive polymeric latches are standard. Stainless steel latches (#316) available as an option for food processing or more demanding applications.

Power connection is easily accomplished through pre-drilled holes. Fixture easily mounts to ceilings and other solid structures, or can be suspended with chain, cable or rod using stainless steel mounting brackets (included).

OPTICS — Injection molded, acrylic lens (.080" thick) provides high impact-resistance comparable to 100% DR. A UV stabilized polycarbonate diffuser (.080" thick) in clear or frosted for additional impact strength where vandal protection is desired.

Expected service life of 60,000 hours at 80% lumen maintenance (L80); predicted life of more than 100,000 hours.

ELECTRICAL — Utilizes high-efficiency LEDs mounted to core circuit boards. High-efficiency drivers operate 120-277 (MVOLT) and 347-480 (HVOLT) offered with 0-10 volt dimming. Standard Luminaire Surge Protection Level: 6kV/3kA Surge Rated per ANSI C82.77-5-2015.

INSTALLATION — Fixture can be surface or suspended mounted. Pre-punched stainless steel mounting brackets are included (two per luminaire) for easy field-attachment of bolts, screws and other mounting hardware. A covered ceiling is not required to maintain wet location listing or IP rating.

LISTINGS — CSA Certified to UL and C-UL Standards. Suitable for wet location. Covered ceiling not required to maintain wet location listing or IP ratings. IP65, IP66, IP67 rated and certified to meet NSF Splash Zone 2. NEMA 4X rated. Sensors maintain IP65 and IP66 only. See chart on page 5 for Ambient Temperatures. DesignLights Consortium® (DLC) Premium qualified product and DLC qualified product. Not all versions of this product may be DLC Premium qualified or DLC qualified. Please check the DLC Qualified Products List at www.designlights.org/QPL to confirm which versions are qualified.

WARRANTY — 5-year limited warranty. Complete warranty terms located at: www.acuitybrands.com/support/customer-support/terms-and-conditions

NOTE: Actual performance may differ as a result of end-user environment and application. All values are design or typical values, measured under laboratory conditions at 25 °C. Specifications subject to change without notice.

Catalog Number
Notes
Type

Low-Profile Enclosed and Gasketed Industrial

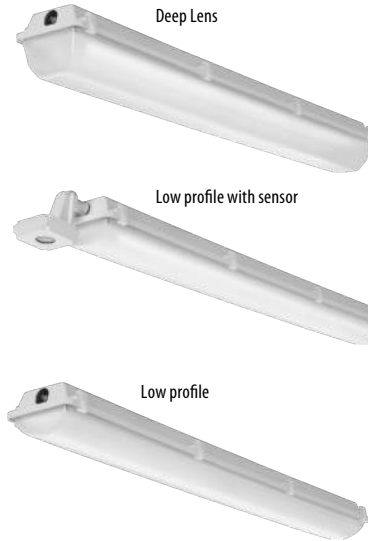

FEM LED

SURFACE/ SUSPENDED MOUNT



Stock configurations are offered for shorter lead times:

Standard Part Number	Stock Part Number
FEM L48 4000LM LPAFL MD MVOLT GZ10 40K 80CRI	FEM L48 4L MVOLT
FEM L48 4000LM LPAFL MD MVOLT GZ10 50K 80CRI	FEM L48 4L MVOLT 5K

A+ Capable Luminaire

This item is an A+ capable luminaire, which has been designed and tested to provide consistent color appearance and out-of-the-box control compatibility with simple commissioning.

- All configurations of this luminaire meet the Acuity Brands' specification for chromatic consistency
- This luminaire is part of an A+ Certified solution for nLight® or XPoint™ Wireless control networks marked by a **shaded background***

To learn more about A+, visit www.acuitybrands.com/aplus.

*See ordering tree for details

FEM LED Low-Profile Enclosed and Gasketed

 A+ Capable options indicated by this color background.

ORDERING INFORMATION

Lead times will vary depending on options selected. Consult with your sales representative.

Example: FEM L48 4000LM IMAFL WD MVOLT GZ10 40K 80CRI

Series	Length	Nominal Lumens	Diffuser	Distribution	Voltage	Driver	Color temperature	CRI
FEM	L24 24" ‡	2000LM 2,000 lumens	IMAFL Acrylic, lineal ribbed frosted lens	MD Medium	MVOLT MVOLT	GZ10 0-10V dimming	30K 3000K	80CRI 80 CRI
		3000LM 3,000 lumens	IMACD Acrylic, clear deep lens	WD Wide	HVOLT 347-480 ‡		35K 3500K	90CRI 90 CRI
		4000LM 4,000 lumens	IMAFD Acrylic, deep frosted lens	PGD Parking garage	120 120V		40K 4000K	
		6000LM 6,000 lumens	LPAFL Acrylic, low profile frosted lens		277 277V		50K 5000K	
			LPACL Acrylic, low profile clear lens		347 347V			
	L48 48" ‡	3000LM 3,000 lumens	LPPCL Polycarbonate, low profile clear lens		480 480V			
		4000LM 4,000 lumens	LPPFL Polycarbonate, low profile frosted lens					
		6000LM 6,000 lumens						
		8000LM 8,000 lumens						
		10000LM 10,000 lumens						
		12000LM 12,000 lumens						
	L96 96" ‡	9000LM 9,000 lumens						
		12000LM 12,000 lumens						
		15000LM 15,000 lumens						
		18000LM 18,000 lumens						
20000LM 20,000 lumens								
	24000LM 24,000 lumens							

Options			
E10WMCP	EM Self-diagnostics battery pack, MVOLT, 10W, Constant Power Certified in the California Title 20 Modernized Appliance Efficiency Database (MAEDBS) ‡	CPSB16YWL BH	6' Brad Harrison 16/3 cord and straight blade plug set ‡
BE6WCP	Cold Weather EM battery pack, 120/277V, 6W, Constant Power Certified in the California Title 20 Modernized Appliance Efficiency Database (MAEDBS) ‡	CPSB16YWL12FTBH	12' Brad Harrison 16/3 cord and straight blade plug set ‡
BGTD	Generator transfer device	CRSB16YWL BH	Brad Harrison receptacle ‡
SPD	Surge protection device, additional 10kV/6kA	CNP16WWL	6' white cord, 16/3, no plug, wet location
WLF	Wet location fitting (two outboard, top (L24 - 20 inches off-center, L48 - 48 inches off-center, L96 - 95.7 inches off-center))	CNP16WWL12FT	12' white cord, 16/3, no plug, wet location
WLFEND	Wet location fitting (one end)	CNP164CWWL	6' white cord, 16/4, no plug, wet location (for use when unswitched circuit is required for battery pack)
WLFEND2	Wet location fitting (both ends) ‡	TRS	Tamper Resistant Torx® T10 screws
WLFMP	Wet location pendant monopoint ‡	DPMB	Dual pendant mounting bracket
ANGBKT	Angle bracket shipped with fixture	STSL	Stainless steel latches
Individual Controls: SBOR10 Low mount 360° integral motion sensor, wet location, On/Off operation SBOR10 HL 3V Low mount 360° integral motion sensor, wet location, High/Low operation (bi-level) SBOR10 P Low mount 360° integral motion sensor, wet location, On/Off operation for motion sensing, override Off due to daylight Xpoint Wireless: XPA SBOR10 Xpoint wireless integral motion sensor, On/Off operation for motion sensing, override Off due to daylight ‡ XAD XPoint™ wireless controller, 0-10V dimming ‡ nLight Air: NLTAIR2 RSBOR10 nLight AIR generation 2 enabled 306 low mount motion sensor NLTAIR2 RIO nLight (wireless) gen 2 dimming & switching module			

NOTE: ‡ indicates option chosen has ordering restrictions. Please reference ordering restrictions chart, page 3. Options are sorted alphanumerically.

See Accessories and ordering restrictions on next page.



FEM LED

INDUSTRIAL: One Lithonia Way, Conyers, GA 30012 Phone: 800-705-SERV (7378) www.lithonia.com

© 2012-2020 Acuity Brands Lighting, Inc. All rights reserved. Rev. 05/05/20

FEM LED Low-Profile Enclosed and Gasketed

‡ Option Value Ordering Restrictions	
Option value	Restriction
L24	Not available with BE6WCP.
L48	Not available with WLFMP.
L96	Not available with WLFMP.
HVOLT	When ordered with L24 available with 6000LM only. When ordered with L48 not available with 3000LM or 4000LM. Not available with XAD or XPA SBOR10.
BE6WCP	Not available with L24 length. Order with CNP164CWWL when unswitched hot is required for battery.
E10WMCP	Order with CNP164CWWL when unswitched hot is required for battery.
WLFEND	Available with cord or sensor option. Choose only one.
WLFEND2	Not available with sensor or cord options.
WLFMP	Available only with L24.
CNP16WWL	Not available with BE6WCP or E10WMCP.
CNP16WWL12FT	Not available with BE6WCP or E10WMCP.
CPSB16YWL BH	Not available with BE6WCP or E10WMCP.
CPSB16YWL12FTBH	Not available with BE6WCP or E10WMCP.
CRSB16YWL BH	Not available with BE6WCP or E10WMCP.
XPA SBOR6	Not available with HVOLT.
XAD	Not available with HVOLT.

Accessories: Order as separate catalog number.	
MHCH 36	Jack chain 36" (pair)
MHHK120	10' single leg air craft cable (ships as pair)
MHHK120SS	10' single leg air craft cable, stainless steel (ships as pair)
RK1 T10BIT W/PIN U	Hex-base driver bit, Torx TX10, for tamper resistant screws with center reject pin
FEMDPMB	Dual pendant mounting bracket (ships as a pair)
FEMANGBKT	Angle bracket (ships as pair)
FEMSMB	Surface mount bracket (ships as pair)

MOUNTING OPTIONS



FEM LED Low-Profile Enclosed and Gasketed

OPERATIONAL DATA (80 CRI*, MD**, MVOLT***)

Length	Package	Input Wattage	CCT	Frosted Lens ¹				Clear Lens ¹		
				IMAFI	IMAFD	LPAFL	LPPFL	IMACD	LPACL	LPPCL
L24	2000LM	13.4	30K	1962 (147)	2083 (156)	2076 (155)	1861 (139)	2112 (158)	2105 (158)	1890 (142)
			35K	2002 (150)	2126 (159)	2118 (159)	1899 (142)	2155 (161)	2147 (161)	1929 (144)
			40K	2099 (157)	2228 (167)	2220 (166)	1991 (149)	2259 (169)	2251 (169)	2022 (151)
			50K	2122 (159)	2252 (169)	2244 (168)	2013 (151)	2284 (171)	2276 (170)	2044 (153)
	3000LM	19.9	30K	2869 (144)	3046 (153)	3035 (153)	2721 (137)	3088 (155)	3077 (155)	2764 (139)
			35K	2927 (147)	3108 (156)	3096 (156)	2777 (140)	3151 (158)	3139 (158)	2820 (142)
			40K	3069 (154)	3258 (164)	3246 (163)	2911 (146)	3303 (166)	3291 (166)	2956 (149)
			50K	3102 (156)	3293 (166)	3281 (165)	2942 (148)	3339 (168)	3327 (167)	2988 (150)
	4000LM	26.0	30K	3676 (142)	3903 (150)	3889 (150)	3487 (134)	3957 (152)	3943 (152)	3541 (136)
			35K	3751 (145)	3982 (153)	3968 (153)	3558 (137)	4037 (156)	4023 (155)	3613 (139)
			40K	3932 (152)	4174 (161)	4159 (160)	3730 (144)	4232 (163)	4217 (162)	3788 (146)
			50K	3975 (153)	4219 (163)	4204 (162)	3770 (145)	4278 (165)	4263 (164)	3829 (148)
6000LM	39.2	30K	5287 (135)	5613 (143)	5593 (143)	5015 (128)	5691 (145)	5671 (145)	5093 (130)	
		35K	5395 (138)	5727 (146)	5707 (145)	5117 (130)	5806 (148)	5786 (147)	5196 (132)	
		40K	5655 (144)	6004 (153)	5982 (153)	5364 (137)	6087 (155)	6065 (155)	5447 (139)	
		50K	5717 (146)	6069 (155)	6047 (154)	5422 (138)	6153 (157)	6131 (156)	5506 (140)	
L48	3000LM	18.0	30K	2689 (149)	2855 (158)	2844 (158)	2551 (141)	2894 (160)	2884 (160)	2590 (144)
			35K	2743 (152)	2912 (161)	2902 (161)	2602 (144)	2953 (164)	2942 (163)	2643 (146)
			40K	2876 (159)	3053 (169)	3042 (169)	2728 (151)	3095 (172)	3084 (171)	2770 (154)
			50K	2907 (161)	3086 (171)	3075 (170)	2758 (153)	3129 (173)	3118 (173)	2800 (155)
	4000LM	23.8	30K	3543 (149)	3762 (158)	3748 (157)	3361 (141)	3814 (160)	3800 (160)	3413 (143)
			35K	3615 (152)	3838 (161)	3824 (161)	3429 (144)	3891 (163)	3877 (163)	3482 (146)
			40K	3790 (159)	4023 (169)	4009 (168)	3595 (151)	4079 (171)	4064 (171)	3650 (153)
			50K	3831 (161)	4067 (171)	4052 (170)	3634 (153)	4123 (173)	4109 (173)	3690 (155)
	6000LM	37.8	30K	5284 (140)	5609 (149)	5589 (148)	5012 (133)	5687 (151)	5667 (150)	5090 (135)
			35K	5391 (143)	5723 (152)	5703 (151)	5114 (135)	5802 (154)	5782 (153)	5193 (138)
			40K	5651 (150)	6000 (159)	5978 (158)	5361 (142)	6083 (161)	6061 (161)	5444 (144)
			50K	5713 (151)	6065 (161)	6043 (160)	5419 (144)	6149 (163)	6127 (162)	5503 (146)
	8000LM	50.5	30K	6952 (138)	7380 (146)	7354 (146)	6594 (131)	7482 (148)	7456 (148)	6696 (133)
			35K	7093 (141)	7530 (149)	7503 (149)	6728 (133)	7634 (151)	7607 (151)	6832 (135)
			40K	7435 (147)	7894 (156)	7865 (156)	7053 (140)	8003 (159)	7975 (158)	7162 (142)
			50K	7516 (149)	7979 (158)	7950 (158)	7129 (141)	8090 (160)	8061 (160)	7240 (144)
	10000LM	62.0	30K	8646 (140)	9179 (148)	9146 (148)	8201 (132)	9306 (150)	9273 (150)	8328 (134)
			35K	8822 (142)	9365 (151)	9332 (151)	8368 (135)	9495 (153)	9461 (153)	8497 (137)
			40K	9248 (149)	9817 (158)	9782 (158)	8772 (142)	9953 (161)	9918 (160)	8908 (144)
			50K	9348 (151)	9924 (160)	9888 (160)	8867 (143)	10061 (162)	10026 (162)	9004 (145)
	12000LM	75.0	30K	10406 (139)	11047 (147)	11007 (147)	9871 (132)	11200 (149)	11160 (149)	10024 (134)
			35K	10617 (141)	11271 (150)	11231 (150)	10071 (134)	11427 (152)	11387 (152)	10227 (136)
			40K	11130 (148)	11816 (157)	11773 (157)	10557 (141)	11979 (160)	11937 (159)	10721 (143)
			50K	11251 (150)	11944 (159)	11901 (159)	10672 (142)	12109 (161)	12066 (161)	10837 (144)
L96	9000LM	53.4	30K	7962 (149)	8452 (158)	8422 (158)	7552 (141)	8570 (160)	8539 (160)	7669 (144)
			35K	8124 (152)	8624 (161)	8593 (161)	7706 (144)	8743 (164)	8713 (163)	7825 (146)
			40K	8516 (159)	9040 (169)	9008 (169)	8078 (151)	9166 (172)	9133 (171)	8203 (154)
			50K	8608 (161)	9138 (171)	9106 (170)	8165 (153)	9265 (173)	9232 (173)	8292 (155)
	12000LM	75.5	30K	10570 (140)	11221 (149)	11181 (148)	10026 (133)	11377 (151)	11337 (150)	10182 (135)
			35K	10785 (143)	11449 (152)	11408 (151)	10230 (135)	11608 (154)	11567 (153)	10388 (138)
			40K	11306 (150)	12002 (159)	11959 (158)	10724 (142)	12168 (161)	12125 (161)	10890 (144)
			50K	11428 (151)	12132 (161)	12089 (160)	10840 (144)	12300 (163)	12257 (162)	11008 (146)
	15000LM	94.3	30K	13399 (142)	14225 (151)	14174 (150)	12710 (135)	14422 (153)	14371 (152)	12907 (137)
			35K	13671 (145)	14513 (154)	14461 (153)	12968 (138)	14714 (156)	14662 (156)	13169 (140)
			40K	14331 (152)	15214 (161)	15160 (161)	13594 (144)	15425 (164)	15370 (163)	13805 (146)
			50K	14487 (154)	15379 (163)	15324 (163)	13741 (146)	15592 (165)	15537 (165)	13954 (148)
	18000LM	103.4	30K	15901 (154)	16881 (163)	16820 (163)	15083 (146)	17114 (165)	17054 (165)	15317 (148)
			35K	16224 (157)	17223 (167)	17161 (166)	15389 (149)	17462 (169)	17400 (168)	15627 (151)
			40K	17007 (164)	18055 (175)	17990 (174)	16132 (156)	18305 (177)	18240 (176)	16382 (158)
			50K	17192 (166)	18251 (176)	18185 (176)	16307 (158)	18503 (179)	18438 (178)	16560 (160)
	20000LM	125.5	30K	17549 (140)	18630 (148)	18564 (148)	16646 (133)	18888 (150)	18822 (150)	16904 (135)
			35K	17906 (143)	19008 (151)	18940 (151)	16984 (135)	19272 (154)	19204 (153)	17247 (137)
			40K	18770 (150)	19927 (159)	19855 (158)	17804 (142)	20202 (161)	20131 (160)	18080 (144)
			50K	18974 (151)	20143 (160)	20070 (160)	17997 (143)	20421 (163)	20349 (162)	18276 (146)
	24000LM	149.5	30K	21142 (141)	22445 (150)	22364 (150)	20055 (134)	22756 (152)	22675 (152)	20365 (136)
			35K	21571 (144)	22900 (153)	22818 (153)	20461 (137)	23217 (155)	23135 (155)	20779 (139)
			40K	22613 (151)	24006 (161)	23920 (160)	21450 (143)	24339 (163)	24253 (162)	21782 (146)
			50K	22858 (153)	24266 (162)	24179 (162)	21682 (145)	24602 (165)	24516 (164)	22018 (147)

* For 90CRI, reduce lumen output by 17.1%
 ** For WD reduce output by 4.7%, PGD reduce output by 5.4%
 *** For HVOLT use scale factor in HVOLT SCALE FACTOR TABLE



FEM LED

INDUSTRIAL: One Lithonia Way, Conyers, GA 30012 Phone: 800-705-SERV (7378) www.lithonia.com

© 2012-2020 Acuity Brands Lighting, Inc. All rights reserved. Rev. 05/05/20

FEM LED Low-Profile Enclosed and Gasketed

CSA LISTED AMBIENT RATING*

		Standard** (surface)"	Standard** (suspended)"	E10WMCP (surface)	E10WMCP (suspended)	BE6WCP (surface)	BE6WCP (suspended)	XAD (surface)	XAD (suspended)
L24	2000LM	35°C	50°C	5°C - 25°C	5°C - 35°C	-20°C - 25°C	-20°C - 35°C	30°C	45°C
	3000LM	35°C	50°C	5°C - 25°C	5°C - 35°C	-20°C - 25°C	-20°C - 35°C	30°C	45°C
	4000LM	35°C	50°C	5°C - 25°C	5°C - 35°C	-20°C - 25°C	-20°C - 35°C	30°C	45°C
	6000LM	35°C	50°C	5°C - 25°C	5°C - 35°C	-20°C - 25°C	-20°C - 35°C	30°C	45°C
L48	3000LM	35°C	50°C	5°C - 25°C	5°C - 35°C	-20°C - 25°C	-20°C - 35°C	30°C	45°C
	4000LM	35°C	50°C	5°C - 25°C	5°C - 35°C	-20°C - 25°C	-20°C - 35°C	30°C	45°C
	6000LM	35°C	50°C	5°C - 25°C	5°C - 35°C	-20°C - 25°C	-20°C - 35°C	30°C	45°C
	8000LM	35°C	50°C	5°C - 25°C	5°C - 35°C	-20°C - 25°C	-20°C - 35°C	30°C	45°C
	10000LM	35°C	50°C	5°C - 25°C	5°C - 35°C	-20°C - 25°C	-20°C - 35°C	30°C	45°C
L96	12000LM	35°C	50°C	5°C - 25°C	5°C - 35°C	-20°C - 25°C	-20°C - 35°C	30°C	45°C
	9000LM	35°C	50°C	5°C - 25°C	5°C - 35°C	-20°C - 25°C	-20°C - 35°C	30°C	45°C
	12000LM	35°C	50°C	5°C - 25°C	5°C - 35°C	-20°C - 25°C	-20°C - 35°C	30°C	45°C
	15000LM	35°C	50°C	5°C - 25°C	5°C - 35°C	-20°C - 25°C	-20°C - 35°C	30°C	45°C
	18000LM	35°C	50°C	5°C - 25°C	5°C - 35°C	-20°C - 25°C	-20°C - 35°C	30°C	45°C
	20000LM	35°C	50°C	5°C - 25°C	5°C - 35°C	-20°C - 25°C	-20°C - 35°C	30°C	45°C
	24000LM	35°C	50°C	5°C - 25°C	5°C - 35°C	-20°C - 25°C	-20°C - 35°C	30°C	45°C

*Minimum Ambient is -30°C unless noted,
 **All options not specifically listed in this table are considered standard

HVOLT SCALE FACTOR

	Factor
2000LM	0.814
3000LM	0.814
4000LM	0.814
6000LM	0.835
8000LM	0.845
9000LM	0.850
10000LM	0.850
12000LM	0.845
15000LM	0.860
18000LM	0.880
20000LM	0.845
24000LM	0.865

CONFIGURATION WEIGHTS

	Standard	w/ Sensor	w/ Battery
L24	8	9	9
L48	11	12	12
L96	23	24	24

NUMBER OF BOARDS AND DRIVERS

Lumen package	Fixture length	Number of boards	Number of drivers
2000LM	L24	1	1
3000LM		1	1
4000LM		1	1
6000LM		1	1
3000LM	L48	2	1
4000LM		2	1
6000LM		2	1
8000LM		2	1
10000LM		2	1
12000LM	L96	2	1
9000LM		4	1
12000LM		4	2
15000LM		4	2
18000LM		4	2
20000LM		4	2
24000LM	4	2	



FEM LED

INDUSTRIAL: One Lithonia Way, Conyers, GA 30012 Phone: 800-705-SERV (7378) www.lithonia.com

© 2012-2020 Acuity Brands Lighting, Inc. All rights reserved. Rev. 05/05/20

FEM LED Low-Profile Enclosed and Gasketed

DIMENSIONS

Specifications subject to change without notice.
All dimensions are inches (centimeters) unless otherwise indicated.

Weight (may vary with options or accessories)
FEM L48: 11.9 lbs (5.397kg)
FEM L96: 24.3 lbs (11.022kg)

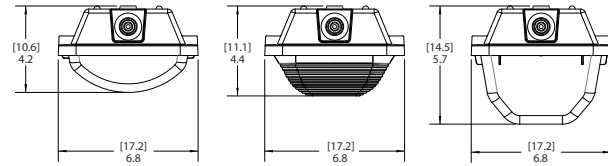
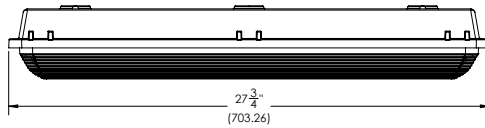
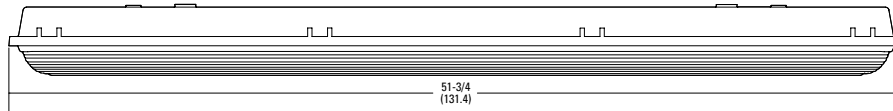
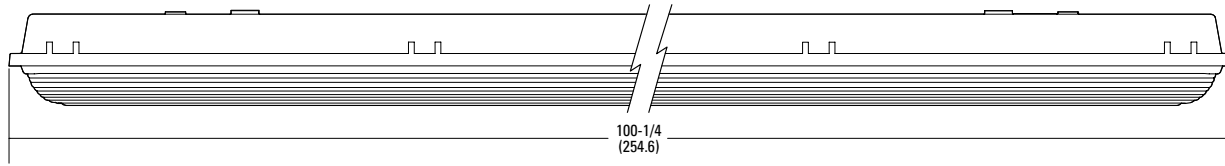

Diffuser Type:
LPAFL
LPACL
LPPFL
LPPCL

Diffuser Type:
IMAFL

Diffuser Type:
IMAFD
IMACD

PHOTOMETRICS

See www.lithonia.com for photometry reports.



FEM LED

INDUSTRIAL: One Lithonia Way, Conyers, GA 30012 Phone: 800-705-SERV (7378) www.lithonia.com

© 2012-2020 Acuity Brands Lighting, Inc. All rights reserved. Rev. 05/05/20

WAC LIGHTING

I Can't Believe It's Not Recessed Ceiling and Wall Mount

Model	Color Temp & CRI	Lumens	Finish
FM-616G2	930 3000K - 90	1050	WT White

Example: **FM-616G2-930-WT**

DESCRIPTION

Multiple mid-powered LEDs illuminate the opaque diffuser uniformly without socket shadows, which are common in conventional flush mounts.

FEATURES

- Imitates a traditional 6" line voltage recessed downlight with an R30 light bulb
- Multiple LED array for uniform illumination
- Driver installed within the Junction Box, driver dimension: 2.875" Dia x 0.875" Deep
- 5 year warranty

SPECIFICATIONS

Construction:	Aluminum with translucent diffuser
Power:	16W
Input:	120 VAC, 50/60Hz
Dimming:	TRIAC: 100-5%, ELV: 100-5%
Light Source:	Integrated LED
Lens:	Translucent acrylic diffuser
Rated Life:	54000 Hours
Mounting:	Installs into a 4" junction box or a combination 3/0-4/0 electrical box, Can be mounted on ceiling or wall in all orientations
Finish:	Electrostatically Powder Coated White
Operating Temp:	-4°F to 104°F (-20°C to 40°C)
Standards:	UL, cUL, Damp Location Listed, Energy Star 2.0, Title 24 JA8-2016 Compliant, ADA

Fixture Type: _____

Catalog Number: _____

Project: _____

Location: _____



FINISHES



White

LINE DRAWING

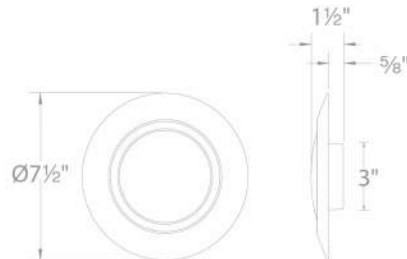

wacighting.com | Phone (800) 526.2588 | Fax (800) 526.2585 | Headquarters/Eastern Distribution Center 44 Harbor Park Drive Port Washington, NY 11050

WAC Lighting retains the right to modify the design of our products at any time as part of the company's continuous improvement program. June 2020



1

WAC LIGHTING

I Can't Believe It's Not Recessed

Ceiling and Wall Mount

Fixture Type: _____

Catalog Number: _____

Project: _____

Location: _____

ACCESSORIES

	<i>Model</i>	<i>Description</i>	<i>Finish</i>
	FM-616-RFK	<i>I Can't Believe It's Not Recessed</i>	-

waclighting.com | Phone (800) 526.2588 | Fax (800) 526.2585 | Headquarters/Eastern Distribution Center 44 Harbor Park Drive Port Washington, NY 11050

WAC Lighting retains the right to modify the design of our products at any time as part of the company's continuous improvement program. June 2020



dweLED

Slice Ceiling Mount

Fixture Type: _____

Catalog Number: _____

Project: _____

Location: _____

Model & Size	Color Temp & CRI	Finish	Watt	LED Lumens	Delivered Lumens	Title 24
FM-4109 9"	2700K 90	BN Brushed Nickel	16.5W	1515	700	Yes
	2700K 90	BZ Bronze	16.5W	1515	700	Yes
	2700K 90	CH Chrome	16.5W	1515	700	Yes
	3000K 90	BN Brushed Nickel	16.5W	1540	720	Yes
	3000K 90	BZ Bronze	16.5W	1540	720	Yes
	3000K 90	CH Chrome	16.5W	1540	720	Yes

Example: **FM-4109-27-BN**

- For alternate color temperature, special order adding -27 or -30 or -35: FM-4115-35-BN
- For 277V special order, add an "F" before the finish: FM-4115F-27-BN

DESCRIPTION

Simple and sweet, Slice packs an illuminating punch of robust illumination. The round centerpiece imparts a rich glow and an understated contemporary style. A clean and simple luminaire that will blend with any interior.

FEATURES

- Etched 3/4" thick pressed glass diffuser with interior ceramic glaze
- Title 24 may not be available for all finishes, check for availability
- ACLED driverless technology
- 5 year warranty

SPECIFICATIONS

Color Temp:	2700K, 3000K
Input:	120 VAC, 50/60Hz
CRI:	90
Dimming:	ELV: 100 - 10%
Rated Life:	45000 Hours
Mounting:	Heavy gauge retention clips support trim firmly. Safety cabling standard., Can be mounted on ceiling or wall in all orientations
Standards:	ETL, cETL, Energy Star 2.0, Title 24 JA8-2016 Compliant Damp Location Listed
Construction:	Durable steel body with thick opal glass



FINISHES

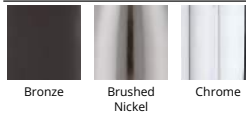

LINE DRAWING

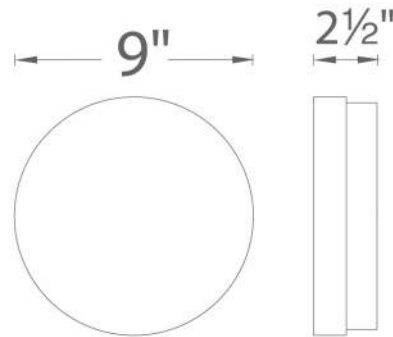

FM-4109

walighting.com | Phone (800) 526.2588 | Fax (800) 526.2585 | Headquarters/Eastern Distribution Center 44 Harbor Park Drive Port Washington, NY 11050

WAC Lighting retains the right to modify the design of our products at any time as part of the company's continuous improvement program. March 2020

dweLED

Slice Ceiling Mount

Fixture Type: _____

Catalog Number: _____

Project: _____

Location: _____

Model & Size	Color Temp & CRI	Finish	Watt	LED Lumens	Delivered Lumens	Title 24
FM-4111 11"	2700K 90	BN Brushed Nickel	26W	2300	1050	Yes
	2700K 90	BZ Bronze	26W	2300	1050	Yes
	2700K 90	CH Chrome	26W	2300	1050	Yes
	3000K 90	BN Brushed Nickel	26W	2315	1080	Yes
	3000K 90	BZ Bronze	26W	2315	1080	Yes
	3000K 90	CH Chrome	26W	2315	1080	Yes

Example: **FM-4111-27-BN**

- For alternate color temperature, special order adding -27 or -30 or -35: FM-4115-35-BN
- For 277V special order, add an "F" before the finish: FM-4115F-27-BN

DESCRIPTION

Simple and sweet, Slice packs an illuminating punch of robust illumination. The round centerpiece imparts a rich glow and an understated contemporary style. A clean and simple luminaire that will blend with any interior.

FEATURES

- Etched 3/4" thick pressed glass diffuser with interior ceramic glaze
- Title 24 may not be available for all finishes, check for availability
- ACLED driverless technology
- 5 year warranty

SPECIFICATIONS

Color Temp:	2700K, 3000K
Input:	120 VAC, 50/60Hz
CRI:	90
Dimming:	ELV: 100 - 10%
Rated Life:	45000 Hours
Mounting:	Heavy gauge retention clips support trim firmly. Safety cabling standard., Can be mounted on ceiling or wall in all orientations
Standards:	ETL, cETL, Energy Star 2.0, Title 24 JA8-2016 Compliant Damp Location Listed
Construction:	Durable steel body with thick opal glass



FINISHES

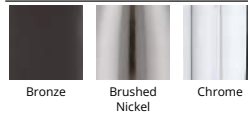

LINE DRAWING

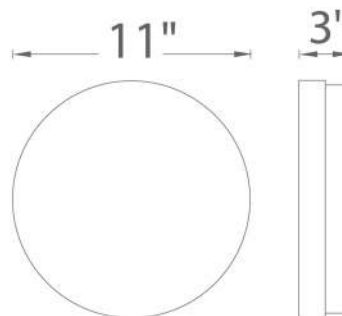

FM-4111

wacighting.com | Phone (800) 526.2588 | Fax (800) 526.2585 | Headquarters/Eastern Distribution Center 44 Harbor Park Drive Port Washington, NY 11050

WAC Lighting retains the right to modify the design of our products at any time as part of the company's continuous improvement program. March 2020

dweLED

Slice Ceiling Mount

Fixture Type: _____

Catalog Number: _____

Project: _____

Location: _____

Model & Size	Color Temp & CRI	Finish	Watt	LED Lumens	Delivered Lumens	Title 24
FM-4115 14"	2700K 90	BN Brushed Nickel	24.7W	2557	1408	No
	2700K 90	BZ Bronze	24.7W	2557	1408	No
	2700K 90	CH Chrome	24.7W	2557	1408	No
	3000K 90	BN Brushed Nickel	25W	2753	1463	Yes
	3000K 90	BZ Bronze	25W	2753	1463	Yes
	3000K 90	CH Chrome	25W	2753	1463	No

Example: **FM-4115-27-BN**

- For alternate color temperature, special order adding -27 or -30 or -35: FM-4115-35-BN
- For 277V special order, add an "F" before the finish: FM-4115F-27-BN

DESCRIPTION

Simple and sweet, Slice packs an illuminating punch of robust illumination. The round centerpiece imparts a rich glow and an understated contemporary style. A clean and simple luminaire that will blend with any interior.

FEATURES

- Etched 3/4" thick pressed glass diffuser with interior ceramic glaze
- Title 24 may not be available for all finishes, check for availability
- ACLED driverless technology
- 5 year warranty

SPECIFICATIONS

Color Temp: 2700K, 3000K
Input: 120 VAC, 50/60Hz
CRI: 90
Dimming: ELV: 100 - 10%
Rated Life: 45000 Hours
Mounting: Heavy gauge retention clips support trim firmly. Safety cabling standard., Can be mounted on ceiling or wall in all orientations
Standards: ETL, cETL, Energy Star 2.0, Title 24 JA8-2016 Compliant
 Damp Location Listed
Construction: Durable steel body with thick opal glass



FINISHES

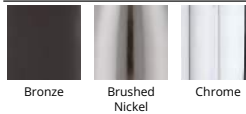

LINE DRAWING

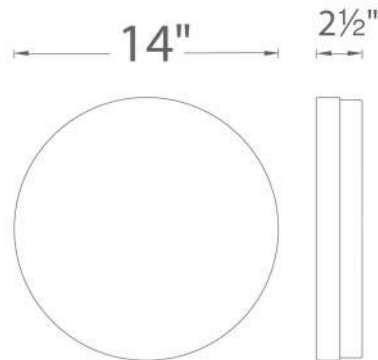

FM-4115

wacighting.com | Phone (800) 526.2588 | Fax (800) 526.2585 | Headquarters/Eastern Distribution Center 44 Harbor Park Drive Port Washington, NY 11050

WAC Lighting retains the right to modify the design of our products at any time as part of the company's continuous improvement program. March 2020

WAC LIGHTING

Turbo Bath & Vanity Light

Model	Color Temp & CRI	Lumens	Finish
WS-180414	30 3000K - 90	950	BN Brushed Nickel
WS-180424	35 3500K - 90	1480	CH Chrome
		1000	
		1570	

Example: **WS-180414-30-BN**

DESCRIPTION

With soft illumination diffused through translucent acrylic, Turbo adds a clean, modern look to baths and other types of modern dcor.

FEATURES

- Multiple LED array for uniform illumination
- Driver concealed within the fixture
- 5 year warranty

SPECIFICATIONS

Construction:	Nickel plated steel with polycarbonate diffuser
Power:	18W, 12W
Input:	120-277 VAC, 50/60Hz
Dimming:	TRIAC: 100-5%, ELV: 100-5%
Light Source:	Integrated LED
	3 Step Mac Adam Ellipse
Rated Life:	50000 Hours
Mounting:	Installs over a 3" or 4" Junction Box, Can be mounted on ceiling or wall in all orientations, Can be mounted on ceiling or wall vertically
Finish:	Electroplated Brushed Nickel, Electroplated Chrome
Operating Temp:	-4°F to 104°F (-20°C to 40°C)
Standards:	ETL, cETL, Damp Location Listed, Energy Star 2.0, Title 24 JA8-2016 Compliant, ADA



FINISHES

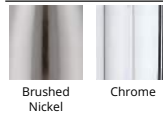

LINE DRAWING

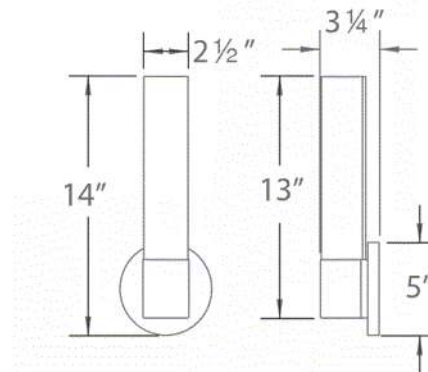

WS-180414

wacighting.com | Phone (800) 526.2588 | Fax (800) 526.2585 | Headquarters/Eastern Distribution Center 44 Harbor Park Drive Port Washington, NY 11050

WAC Lighting retains the right to modify the design of our products at any time as part of the company's continuous improvement program. March 2020



1

Catalog Number
Notes
Type

FEATURES & SPECIFICATIONS

INTENDED USE — For wall or ceiling mounting, vertical or horizontal. The WL combines digital LED lighting and controls technologies with high-performance optical design to offer the most advanced wall-mount luminaire for general ambient lighting applications. High-efficacy light engine delivers long life and excellent color, ensuring a superior quality lighting installation that is highly efficient and sustainable.

CONSTRUCTION — Housing is roll formed from code-gauge steel.

Refractor is retained in die cast ends providing secure installation and easy maintenance.

Decorative die-cast end caps provide added durability.

Finish: End caps are post-painted in white polyester powder coat for smooth finish. Post-painted channel available by selecting PAF option.

OPTICS — Impact modified linear faceted refractor. Optically engineered for superior light distribution and maximum efficacy.

Crescent-shape linear faceted refractor system obscures and integrates individual LED images and uniformly washes fixture surface with light.

ELECTRICAL — Long-life LEDs, coupled with high-efficiency drivers, provide superior quantity and quality of illumination for extended service life. 90% LED lumen maintenance at 60,000 hours (L90/60,000). The LEDs have a CRI of 82.

eldoLED driver options deliver choice of dimming range and choice for control, while assuring flicker-free, low-current inrush, 89% efficiency and low EMI.

Driver disconnect provided where required to comply with US and Canadian codes.

Optional nLight® embedded controls continuously monitor system performance and allow for constant lumen management function.

Lumen Management: Unique lumen management system (option N80) provides onboard intelligence that actively manages the LED light source so that constant lumen output is maintained over the system life, preventing energy waste created by the traditional practice of over-lighting.

SENSOR — **Integrated sensor (individual control):** Sensor Switch MSD7 (Passive Infrared (PIR)) integrated occupancy sensor photocell allows the luminaire to power off when the space is unoccupied. See page 4 for more details on the integrated sensor.

Integrated Sensor (nLight Wired Networking): The sensor is nLight-enabled, meaning it has the ability to communicate over an nLight network. When wired using CAT-5 cabling with other nLight-enabled sensors, power packs, or WallPods, an nLight control zone is created. Once linked to a Gateway, directly or via a Bridge, the zone becomes capable of remote status monitoring and control via SensorView software. See page 4 for the nLight sensor options.

Interated Smart Sensor (nLight AIR Wireless Platform): The RES7 sensor is nLight AIR enabled, meaning it has the ability to communicate over the wireless nLight control platform. It is available with an automatic dimming photocell, and either a digital PIR or a dual technology occupancy sensor. It pairs to other luminaires and wall switches through our mobile app, CLAIRITY, which allows for simple sensor adjustment. See page 4 for more details on the Integrated Smart Sensor.

LISTINGS — CSA certified to meet U.S. and Canadian standards. Suitable for damp location (excluding sensor option).

Patents pending. DesignLights Consortium® (DLC) qualified product. Not all versions of this product may be DLC qualified. Please check the DLC Qualified Products List at www.designlights.org/QPL to confirm which versions are qualified.

WARRANTY — 5-year limited warranty. Complete warranty terms located at: www.acuitybrands.com/CustomerResources/Terms_and_conditions.aspx

NOTE: Actual performance may differ as a result of end-user environment and application. All values are design or typical values, measured under laboratory conditions at 25 °C. Specifications subject to change without notice.

W SERIES

Wall bracket & Surface Mount LED



WL4

4'
LED



A+ Capable Luminaire

This item is an A+ capable luminaire, which has been designed and tested to provide consistent color appearance and out-of-the-box control compatibility with simple commissioning.

- All configurations of this luminaire meet the Acuity Brands' specification for chromatic consistency
- This luminaire is part of an A+ Certified solution for nLight® or XPoint™ Wireless control networks when ordered with drivers marked by a **shaded background***

To learn more about A+, visit www.acuitybrands.com/aplus.

*See ordering tree for details

WL4 Wall Bracket & Surface Mount LED

 A+ Capable options indicated by this color background.

ORDERING INFORMATION Lead times will vary depending on options selected. Consult with your sales representative.

Example: WL4 30L EZ1 LP840

WL4					
Series	Lumens ¹	Voltage	Driver	Color temperature	nLight Interface
WL4 4' wall-mount LED	20L 2000 lumens	(blank) MVOLT	EZ1 eldoLED dims to 1%, 0-10V	LP830 3000 K	nLight Wired (blank) No nLight® interface N80 nLight® with 80% lumen management N80EMG nLight® with 80% lumen management. For use with generator supply EM power ⁴ N100 nLight® without lumen management N100EMG nLight® without lumen management. For use with generator supply EM power ⁴ nLight Wireless (blank) No nLight® interface NLTAIR2 nLight® Air Generation 2 enabled ⁵
	30L 3000 lumens	347 347V	EZB eldoLED dims to dark, 0-10V	LP835 3500 K	
	40L 4000 lumens		GZ1 Dims to 1% (0-10V dimming) ²	LP840 4000 K	
			GZ10 Dims to 10% (0-10V dimming) ²	LP850 5000 K	
			SLD Step-level dimming ³		

Control ⁶	Standby mode ⁹	Options	Finish ¹²
nLight Wired (blank) No nLight control NES7 nLight® nES 7 PIR integral occupancy sensor ⁷ NESPDT7 nLight® nES PDT 7 dual technology integral occupancy control ⁷ NES7ADCX nLight® nES 7 ADCX PIR integral occupancy sensor with automatic dimming photocell ⁷	(blank) Fixture turns off when unoccupied DIM10 Fixture dims to approximately 10% light output when unoccupied DIM50 Fixture dims to approximately 50% light output when unoccupied NOC NOC Occupancy sensor disabled ¹⁰	EL7L 700 nominal lumen battery pack (Noncompliant with CA T20) ¹¹ EL14L 1400 nominal lumen battery pack (Noncompliant with CA T20) ¹¹ E10WLCP EM Self-Diagnostic battery pack, 10W Constant Power, Certified in CA Title 20 MAEDBS ¹¹ SC Surface conduit end cap provisions	(blank) White PAF Paint After Fabrication White
nLight Wireless RES7 nLight® AIR PIR integral occupancy sensor with automatic dimming photocell RES7PDT nLight® AIR microphonics dual technology integral occupancy sensor with automatic dimming photocell			
Individual Control MSD7 Sensor Switch® MSD 7 PIR Integral Occupancy Control ⁸			

Notes

- 1 Approximate lumen output.
- 2 Not available with any Controls or sensor options.
- 3 Not available with nLight Interface or Controls.
- 4 nLight EMG option requires a connection to existing nLight network. Power is provided from a separate N80 or N100 enabled fixture
- 5 Must order with RES7, RES7PDT, or module. Only available with EZ1 driver.
- 6 See sensor options on page 4.
- 7 Requires N80, N100, N80EMG, or N100EMG.
- 8 Not available with nLight options or EZB.
- 9 Only available with nLight Wired occupancy sensors options.
- 10 Can only be ordered in conjunction with EZ1, NLTAIR2, RES7/RES7PDT. Occupancy sensor disabled at factory but can be re-enabled upon commissioning.
- 11 Not available with 347V.
- 12 For additional paint finishes, refer to [Architectural Colors](#).



WL4-LED

COMMERCIAL INDOOR: One Lithonia Way Conyers, GA 30012 Phone: 1-800-705-SERV (7378) www.lithonia.com

© 2016-2019 Acuity Brands Lighting, Inc. All rights reserved. Rev. 12/13/19

WL4 Wall Bracket & Surface Mount LED

nLight® Wired Control Accessories:

Order as separate catalog number. Visit www.acuitybrands.com/products/controls/nlight.

WallPod stations	Model number	Occupancy sensors	Model number
On/Off	nPODM [color]	Small motion 360°, ceiling (PIR / dual tech)	nCM 9 RJB / nCM PDT 9 RJB
On/Off & raise/lower	nPODM DX [color]	Large motion 360°, ceiling (PIR / dual tech)	nCM10 RJB / nCM PDT 10 RJB
Graphic touchscreen	nPOD GFX [color]	Wall switch with raise/lower	nWSX PDT LV DX [color]
Photocell controls	Model number	Cat-5 cable (plenum rated)	Model number
Full range dimming	nCM ADCX RJB	10' cable	CAT5 10FT J1
		30' cable	CAT5 30FT J1

nLight® AIR Control Accessories:

Order as separate catalog number. Visit www.acuitybrands.com/products/controls/nlightair.

Wall switches	Model number
On/Off single pole	rPODB [color] G2
On/Off two pole	rPODB 2P [color] G2
On/Off & raise/lower single pole	rPODB DX [color] G2
On/Off & raise/lower two pole	rPODB 2P DX [color] G2
On/Off & raise/lower single pole	rPODBZ DX WH G2

ORDERING INFORMATION

rCMS		Example: RCMS PDT 10 AR G2						
Series/Detection	Occupancy Detection	Lens (Required)			Operating Mode		Generation	
RCMS nLight AIR occupancy and daylight sensor	(blank) PIR Detection PDT Dual Tech PIR/ Microphonics	10	Large Motion/Extended Range 360°		(blank)	None	G2 Generation 2 compatibility	
		9	Small Motion/Extended Range 360°		AIR	Auxiliary Relay		
		6	High Bay 360° Lens					



RCMS



WL4 Wall Bracket & Surface Mount LED

Sensor Options					
Option	Automatic Dimming Photocell	Occupancy Sensing		nLight Wired Networking	nLight AIR Networking
		PIR	PDT		
MSD7		X			
NES7		X		X	
NES7ADCX	X	X		X	
NESPD7			X	X	
RES7	X	X			X
RES7PDT	X	X	X		X

Integrated Sensor with Individual Control

The MSD7 PIR occupancy sensor is ideal for areas without obstructions and where daylight harvesting may be desired. Suggested applications include, but not limited to, hallways, corridors, storage rooms, and breakrooms or other areas where people are typically moving.

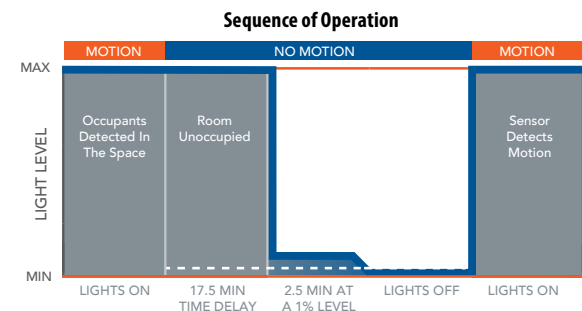

Sensor Coverage Pattern Mini 360° Lens

- Recommended for walking motion detection from mounting heights between 8 ft (2.44 m) and 20 ft (6.10 m)
- Initial detection of walking motion along sensor axes at distances of 2x the mounting height up to 15 ft (4.57 m) and 1.75x up to 20 ft (6.10 m).
- Provides 12 ft (3.66 m) radial detection of small motion when mounted at 9 ft (2.74 m)
- Initial detection will occur earlier when walking across sensor's field of view than when walking directly at sensor

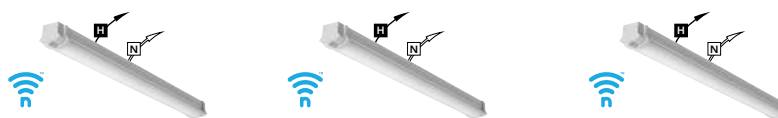
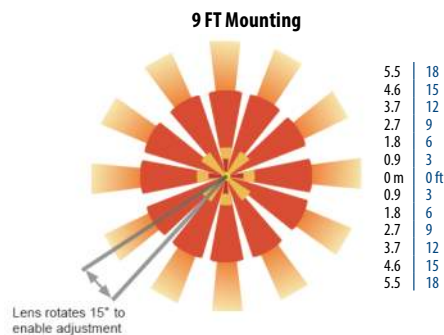

Simple as 1,2,3

1. Install the nLight® AIR fixtures with embedded smart sensor
2. Install the wireless battery-powered wall switch
3. With CLAIRITY app, pair the fixtures with the wall switch and if desired, customize the sensor settings for the desired outcome



nLight AIR iPODB 2P DX

Mobile Device

Basic nLight Zone



nLight Wired Networking

The nES 7 is ideal for small rooms without obstructions or areas with primarily walking motion. Ideal areas include hallways, corridors, storage rooms, and breakrooms. Additionally, the NES7ADCX includes an integrated photocell, which enables daylight harvesting controls.

For areas like restrooms, private offices, open offices, conference rooms or any space with obstructions, the nES PDT 7 dual technology sensor is recommended. The nES PDT 7 utilizes both PIR (passive infrared) and Microphonics technologies to detect occupancy.

nLight AIR Wireless

nLight AIR is the ideal solution for retrofit or new construction spaces where adding additional wiring can be labor intensive and costly. nLight AIR is available with or without an integral sensor. The integrated RES7 or RES7PDT smart sensors are part of each luminaire in the nLight AIR network, which can be grouped to control multiple luminaires. The granularity of control with the digital PIR occupancy detection and daylight sensing makes a great solution for any application.

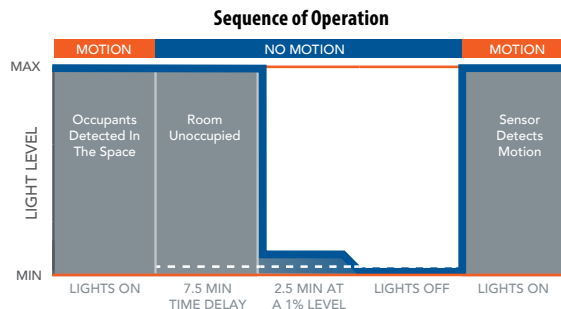

*The presetting on the automatic dimming photocell is 5fc.

WL4 Wall Bracket & Surface Mount LED

Performance Data			
Lumen package	Input watts	Lumens	LPW
20L LP830	18.7	2050	110
20L LP835	18.7	2152	115
20L LP840	18.7	2255	121
20L LP850	18.7	2410	129
30L LP830	28.2	2952	105
30L LP835	28.2	3095	110
30L LP840	28.2	3251	115
30L LP850	28.2	3239	115
40L LP830	39.5	3927	99
40L LP835	39.5	4124	104
40L LP840	39.5	4325	110
40L LP850	39.5	4571	116

DIMENSIONS

All dimensions are inches (centimeters) unless otherwise noted.

Specifications

Length: with sensor - 50-15/16 (129.40)
 without sensor - 46-13/16 (118.90)
 Height: with sensor - 3-7/8 (9.7)
 without sensor - 3-11/16 (9.3)
 Width: 4-3/4 (12.1)

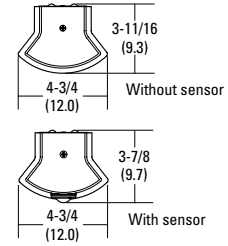

How to Calculate Estimated Lumens in Emergency Mode

Use the formula below to estimate the delivered lumens in emergency mode

$$\text{Delivered Lumens} = 1.25 \times P \times \text{LPW}$$

P = Output power of emergency driver. P = 10W for E10WLCP option.

LPW = Lumen per watt rating of the luminaire. This information is available on the ABL luminaire spec sheet.

LPW = Lumen per watt rating of the luminaire. LPW information available in Performance Data section.

PHOTOMETRICS

WL4 30L EZ1 LP840, 3250.8 delivered lumens, test no. LTL25482P5, tested in accordance to IESNA LM-79

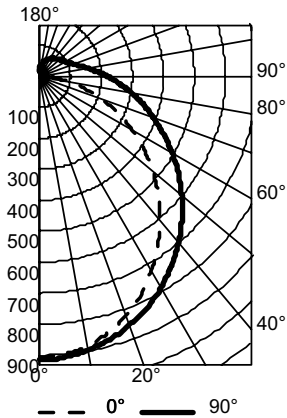

CP Summary

	0°	90°
0°	912	912
5°	901	910
15°	856	879
25°	777	823
35°	666	745
45°	542	650
55°	412	549
65°	279	444
75°	151	346
85°	44	257
90°	5	219

Coefficients of Utilization

ROR	pf	20%								
		80%			70%			50%		
	pc	70%	50%	30%	50%	30%	10%	50%	30%	10%
0	116	116	116	112	112	112	104	104	104	
1	104	99	94	95	91	87	88	85	81	
2	94	85	78	82	75	70	76	71	66	
3	85	74	66	72	64	57	67	60	55	
4	78	66	56	63	55	48	59	52	46	
5	72	58	49	57	48	42	53	46	40	
6	66	52	43	51	42	36	48	40	35	
7	61	47	39	46	38	32	43	36	31	
8	57	43	35	42	34	28	40	32	27	
9	53	40	31	39	31	25	36	29	25	
10	50	37	29	36	28	23	34	27	22	

Zonal Lumen Summary

Zone	Lumens	% Lamp	% Fixture
0° - 30°	701	21.6	21.6
0° - 40°	1143	35.2	35.2
0° - 60°	2032	62.5	62.5
0° - 90°	2829	87.0	87.0
90° - 120°	256	7.9	7.9
90° - 130°	310	9.5	9.5
90° - 150°	386	11.9	11.9
90° - 180°	421	13.0	13.0
0° - 180°	3251	100.0	100.0

MOUNTING DATA

For unit installation; surface ceiling or wall mounting.

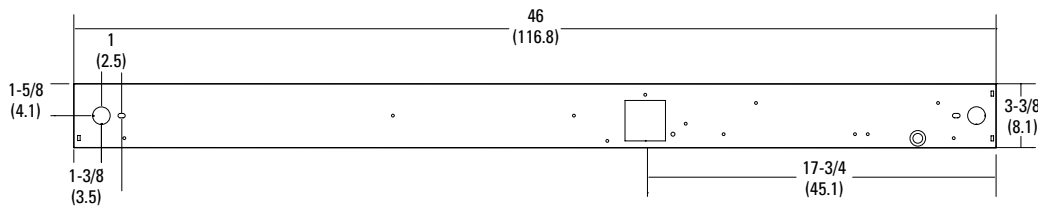

VL61236

Specification Sheet

Wall Sconce



CH - Chrome

Other Finishes:



BK - Black

Product Features

Simplistic Modern LED with obround shaped white acrylic finished with chrome end caps and matching canopy (optional). Equipped with our powerful 120V AC LED technology, 40W, fully dimmable and may be mounted horizontally or vertically. Available in three different sizes.

Product Details

High system efficacy
 Low total life cycle cost
 No visible flicker AC operation
 ETL Listed
 1-year fixture warranty and 5-year LED board warranty.
 Complete warranty terms located at:
www.kuzcolighting.com/warranty
 Utilizes our patented Driverless LED Light Engine technology - connects directly to AC, no external driver needed.
 Available in chrome and black metal finish with obround white acrylic diffuser.
 Dimmable with ELV dimmer (not included)
 Custom options available

PROJECT		V 1.0			
DATE		TYPE			
Voltage	Watts	LED Lumens	Delivered Lumens	Finish(es)	
120V	40W*	3600lm*	2442lm*	CH - Chrome	Color Temp 3000K
120V	40W*	3600lm*	2442lm*	BK - Black	CRI (Ra) >90
					Dimming 100% - 10%
					Rated Life 50,000 hours

*Preliminary figures

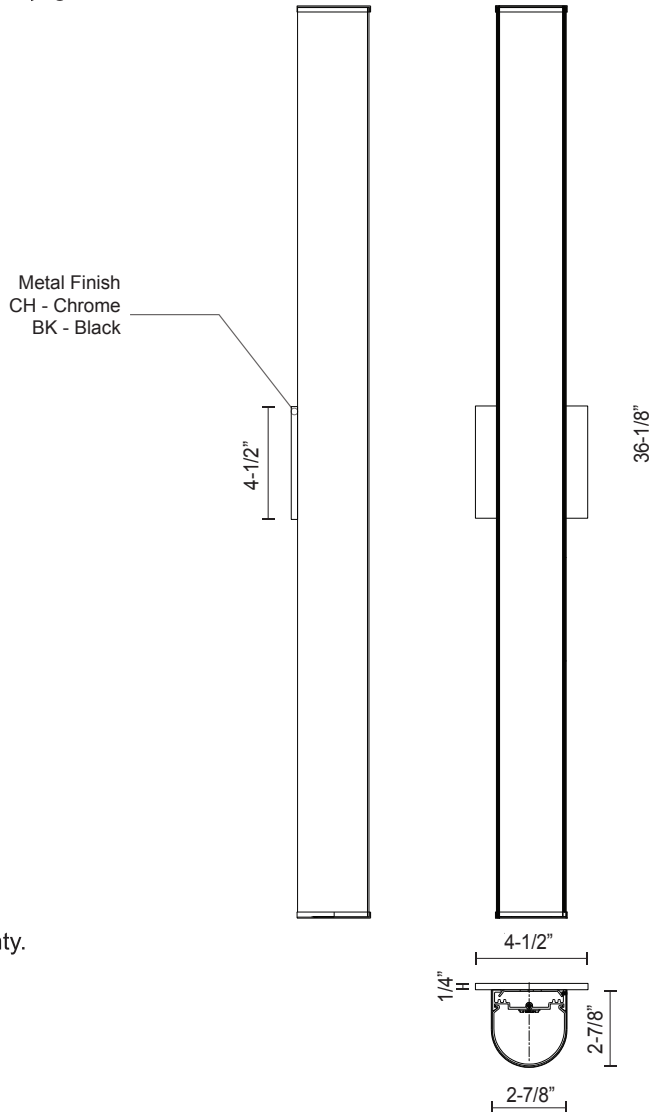

Canopy dimensions:
 L4-1/2" x W4-1/2" x E1/4"

Comments:

KUZCO
 LIGHTING
 20170710

19054 28th Avenue
 Surrey, BC, Canada
 V3Z 6M3

T: 604 538 7162
 F: 604 538 7196
 W: Kuzcolighting.com



PITCH SINGLE WALL SCONCE

An architectural profile reminiscent of beautifully classic roof lines delivers significant light output in this modern LED wall sconce suitable for both indoor and outdoor applications. The Pitch Single's die-cast metal body houses powerful LED light sources that create visual appeal as light cascades down along a wall.

High quality LM80-tested LEDs
for consistent long-life performance and color

- Outstanding protection against the elements:**
- Powder coat finishes
 - Stainless Steel mounting hardware
 - Impact-resistant, UV stabilized frosted acrylic lensing

Can be mounted for up lighting or down lighting

SPECIFICATIONS

DELIVERED LUMENS	822.6
WATTS	26.1
VOLTAGE	120V, 277V
DIMMING	ELV
LIGHT DISTRIBUTION	Symmetric
MOUNTING OPTIONS	Downlight or Uplight
CCT	2700K, 3000K
CRI	80+
COLOR BINNING	3 Step
BUG RATING	B1-U0-G0
DARK SKY	Compliant (Downlight)
WET LISTED	IP65
GENERAL LISTING	ETL
CALIFORNIA TITLE 24	Can be used to comply with CEC 2016 Title 24 Part 6 for outdoor use. Registration with CEC Appliance Database not required.
START TEMP	-30°C
FIELD SERVICEABLE LED	No
CONSTRUCTION	Aluminum
HARDWARE	Stainless Steel
FINISH	Powder Coat
LED LIFETIME	L70; 70,000 Hours
WARRANTY*	5 Years
WEIGHT	1.2 lbs.

* Visit techlighting.com for specific warranty limitations and details.

ORDERING INFORMATION

700WSPIT	SIZE	FINISH	LAMP
S	SINGLE	B BLACK	-LED827 LED 80 CRI, 2700K 120V
		Z BRONZE	-LED827277 LED 80 CRI, 2700K 277V
		H CHARCOAL	-LED830 LED 80 CRI, 3000K 120V
		I SILVER	-LED830277 LED 80 CRI, 3000K 277V



PITCH SINGLE
shown in black



PITCH SINGLE
shown in bronze



PITCH SINGLE
shown in charcoal



PITCH SINGLE
shown in silver

PITCH SINGLE WALL SCONCE

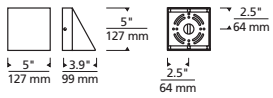

Pitch Single

PHOTOMETRICS*

*For latest photometrics, please visit www.techlighting.com/OUTDOOR

PITCH SINGLE

- Total Lumen Output: 822.6
- Total Power: 26.2
- Luminaire Efficacy: 31.4
- Color Temp: 3000K
- CRI: 80+
- BUG Rating: B1-U0-G0

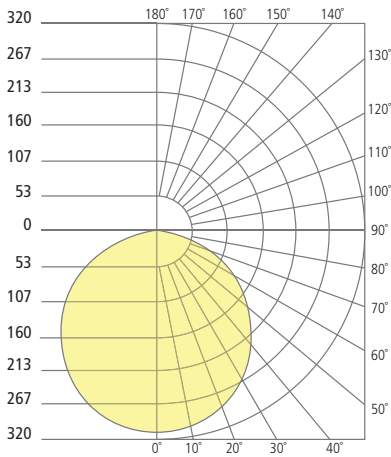

PROJECT INFO

FIXTURE TYPE & QUANTITY

JOB NAME & INFO

NOTES



VISUAL COMFORT & Co.

7400 Linder Avenue, Skokie, Illinois 60077
T 847.410.4400 F 847.410.4500



© 2020 Tech Lighting, L.L.C. All rights reserved. The "Tech Lighting" graphic is a registered trademark. Tech Lighting reserves the right to change specifications for product improvements without notification.

techlighting.com

FEATURES & SPECIFICATIONS

INTENDED USE — Suitable for applications requiring attractive edge-lit exit signage, universal installation and low energy consumption.

CONSTRUCTION — Extruded brushed aluminum finish.

Clear acrylic panels- letters measure 6" high with 3/4" stroke, with 100 ft viewing distance rating, based upon UL 924 standard.

For single-face clear panels, EXIT is seen as a reversed image from the back.

OPTICS — LEDs mounted on printed circuit board. The typical life of the exit LED lamp is 10 years.

The LED operating frequency is 120Hz.

ELECTRICAL — Dual voltage input capacity (120/277V).

Battery: (EL Option) — Sealed, maintenance free nickel-cadmium battery delivers 90 minutes capacity to emergency lamps. Test switch provides manual activation of 30-second diagnostic testing for on-demand visual inspection.

Self-diagnostic testing (EL Option Only) for 30 seconds every 30 days and 90 minutes annually. Diagnostic evaluation of LED light source, AC to DC transfer, charging and battery condition.

INSTALLATION — EDG — Universal surface (top, end or back) mounting. Canopy provided.

EDGR — Recessed mounting. Bar hanger and brackets provided for both new or restricted ceiling access installation applications. Back wall mount (WM) option.

Universal directional indicators. Field selected and attached.

LISTINGS — UL damp location listed 32°-122°F (0°-50°C) standard. Meets UL924, NFPA 101 (current Life Safety Code), NEC and OSHA illumination standards.

WARRANTY — 5-year limited warranty. Complete warranty terms located at:

www.acuitybrands.com/support/customer-support/terms-and-conditions

NOTE: Actual performance may differ as a result of end-user environment and application.

All values are design or typical values, measured under laboratory conditions at 25°C.

Specifications subject to change without notice.

Catalog Number
Notes
Type



EDG (surface mount)



EDGR (recessed mount)

LED Edge-Lit Exits

EDG EDGR

LED Lamps



Specifications

EDG (End Mount)	EDG (Top Mount)
Length: 13-5/8 (34.6)	Length: 13 (33.0)
Depth: 5-1/2 (14.0)	Depth: 4-5/16 (11.0)
Height: 11-1/8 (28.3)	Height: 11-3/4 (29.8)
Shipping Weight : 4 lbs (1.8 kgs)	Shipping Weight : 4 lbs (1.8 kgs)
EDG (Back Mount)	EDGR
Length: 13 (33.0)	Length: 13 (33.0)
Depth: 3 (7.6)	Depth: 1-3/4 (4.4)
Height: 11-1/8 (28.3)	Height: 8 (20.3)
Shipping Weight : 4 lbs (1.8 kgs)	Shipping Weight : 6.8 lbs (3.1 kgs)
	Shipping Weight (WM option) : 8.1 lbs (3.7 kgs)

All dimensions are inches (centimeters) unless otherwise noted.

ORDERING INFORMATION For shortest lead times, configure products using **bolded options**.

Example: EDG 1 R EL

Family	Housing color	Number of faces	Letter color	Operations	Options
EDG Surface mount LED edge-lit exit	(blank) Brushed aluminum	1 Single face	R Red on clear (single face only) ¹	(blank) AC only	(blank) None
EDGR Recessed LED edge-lit exit	W White	2 Double face	G Green on clear (single face only) ¹	EL Nickel-cadmium battery	WM Recessed wall mount ⁶
			RMR Red on mirror ²	X2 Lamp wired on two separate AC circuits (specify 120V or 277V) ⁴	
			GMR Green on mirror ²	SD Self-diagnostics ⁵	
			RW Red on white ³		
			GW Green on white ³		

Accessories: Order as separate item.	
ELA US12	12" stem kit with brushed aluminum canopy ⁷
ELA W US12	12" stem kit with white canopy ⁷
ELA WG1	Wireguard ⁸

Notes

- For single-face clear panels, EXIT is seen as a reversed image from the back.
- Available with single and double face.
- White panel standard for double and single face.
- Not available with EL and SD options. Both circuits can be energized at the same time.
- Available with EL option only.
- Available on EDGR single face only
- See spec sheet [ELA-StemKits](#). Only available for EDG.
- Back mount only.

EMERGENCY

EDG-EDGR

EDG-EDGR LED, Surface and Recessed Mount Edge-Lit Exits

SPECIFICATIONS

ELECTRICAL						
Primary Circuit						
Type	Typical LED life ¹	Supply voltage	EDG		EDGR	
			Input Watts	Max amps.	Input Watts	Max amps.
Red LED AC only	10 years	120	2.5	0.020	3.8	0.030
		277	2.8	0.010	4.5	0.014
Green LED AC only	10 years	120	2.2	0.020	3.8	0.030
		277	2.2	0.010	4.5	0.020
Red LED emergency	10 years	120	3.0	0.030	3.8	0.031
		277	3.1	0.010	4.5	0.015
Green LED emergency	10 years	120	2.6	0.020	3.8	0.031
		277	2.8	0.010	4.5	0.020

BATTERY (EL option)			
Sealed Nickel-Cadmium			
Shelf life ²	Typical life ²	Maintenance ³	Optimum temperature ⁴
3 years	7-9 years	none	32-122°F (0-50°C)

- Notes
- Based on continuous operation. The typical life of the exit LED lamp is 10 years.
 - At 77°F (25°C).
 - All life safety equipment, including emergency lighting for path of egress must be maintained, serviced, and tested in accordance with all National Fire Protection Association (NFPA) and local codes. Failure to perform the required maintenance, service, or testing could jeopardize the safety of occupants and will void all warranties.
 - Optimum ambient temperature range where unit will provide capacity for 90 minutes. Higher and lower temperatures affect life and capacity.

KEY FEATURES

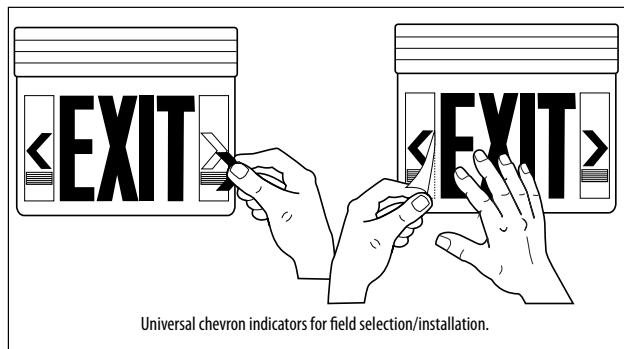

MOUNTING

EDG

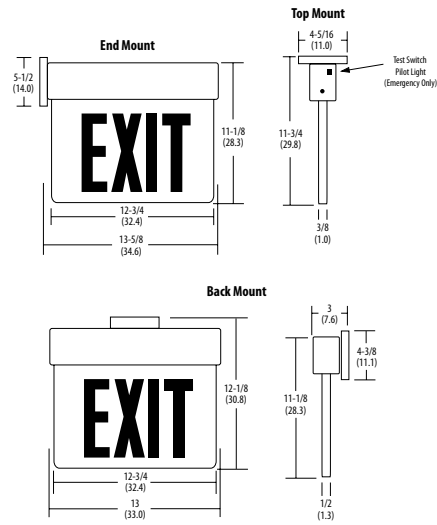

EDGR

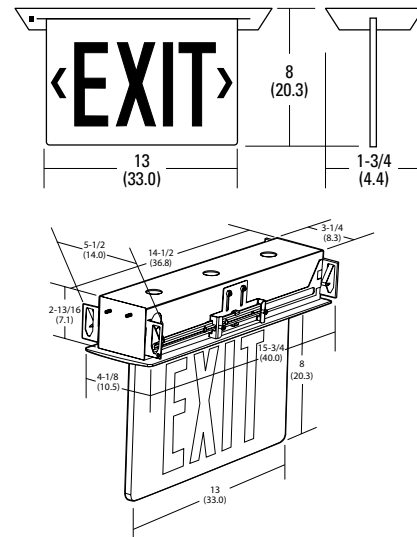

EDGR WM option

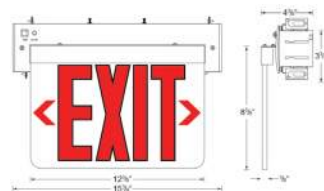

Catalog Number
Notes
Type

FEATURES & SPECIFICATIONS

INTENDED USE — Ideal for wet location areas requiring exit signs for AC only or battery back-up power that are subject to saturation with non-mechanically delivered water.

CONSTRUCTION — White, compact, contemporary design. Engineering-grade thermoplastic housing is impact-resistant, scratch-resistant and corrosion-proof. Universal directional Chevron inserts are easily removed and reinserted. UL94V-0 flame rating. UV-stable resin resists discoloration from natural and man-made light sources. Rugged, heavy-duty, polycarbonate clear housing lens. Housing also available in black or gray. Letters 6" high with 3/4" stroke, with 100 ft. viewing distance rating, based upon UL924 standards.

OPTICS — Low energy consumption — fewer than 5 watts. The typical life of the exit LED lamp is 10 years, based on continuous operation.

ELECTRICAL — Dual voltage input capacity (120/277V).

Battery: (EL Option) – Sealed, maintenance free nickel-cadmium battery delivers 90 minutes rated capacity. Test switch provides manual activation of 30-second diagnostic testing for on-demand visual inspection.

Self-diagnostic testing (SD Option Only) for 30 seconds every 30 days, 30 minutes every 180 days and a 90-minute annual test. Diagnostic evaluation of LED light source, charging and battery condition.

INSTALLATION — Universal (top, end or back mount), canopy included. Junction box hole pattern for 4" octagon mounting. Flexible conduit entry.

LISTINGS — UL listed. Wet location listed. Standard cold temperature rating -4°F to 122°F (-20°C to 50°C). Meets UL 924, NFPA 101 (current Life Safety Code) and NFPA 70-NEC

WARRANTY — 5-year limited warranty. (Battery is prorated.) Complete warranty terms located at www.acuitybrands.com/CustomerResources/Terms_and_conditions.aspx

Note: Actual performance may differ as a result of end-user environment and application. All values are design or typical values, measured under laboratory conditions at 25 °C. Specifications subject to change without notice.



**Wet Location
Exit Sign**

WLTE



Specifications

Length: 12-1/2 (31.8)

Depth: 2-1/2 (6.4)

Height: 8-1/8 (20.6)

Weight: 4.1 lbs (1.9 kg)

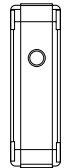
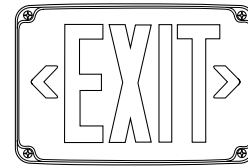

All dimensions are inches (centimeters) unless otherwise indicated.

ORDERING INFORMATION

Lead times will vary depending on options selected. Consult with your sales representative.

Example: WLTE W 1 R EL

Series	Housing color	Number of faces	Letter color	Operation	Options
WLTE	W White B Black GY Gray	1 Single face 2 Double face	R Red G Green	(blank) AC only EL Nickel-cadmium battery	TP Tamper-resistant screw hardware SD Self-diagnostics ¹

Accessories: Order as separate catalog number. ²	
ELA WG1	Wireguard (back mount only)

Notes

- 1 Only available with EL option.
- 2 See spec sheet [ELA-WG](#).

EMERGENCY

WLTE

WLTE Wet Location Exit Sign

SPECIFICATIONS

ELECTRICAL				
Primary circuit				
Type ¹	Typical LED life ²	AC volts	Input watts	Max. amps
Red LED	10 years	120	2.7	0.03
		277	2.7	0.02
Green LED	10 years	120	3.3	0.03
		277	3.4	0.02

BATTERY				
Ni-Cad				
Voltage	Shelf life ³	Typical life ³	Maintenance ⁴	Temperature range ⁵
4.8	3 years	7-9 years	none	-4° – 122°F (-20° – 50°C)

Notes

- LED lamps operate in normal (AC input) and emergency (DC input) modes.
- Based on continuous operation. The typical life of the exit LED lamp is 10 years.
- At 77°F (25°C).
- All life safety equipment, including emergency lighting for path of egress, must be maintained, serviced and tested in accordance with all National Fire Protection Association (NFPA) and local codes. Failure to perform the required maintenance, service or testing could jeopardize the safety of occupants and will void all warranties.
- Optimum ambient temperature range where unit will provide capacity for 90 minutes. Higher and lower temperatures affect life and capacity.

MOUNTING

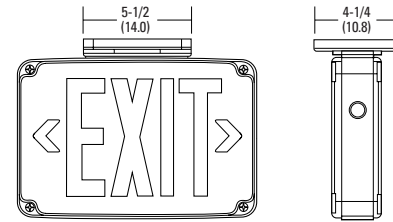

Specifications

Length: 12-1/2 (31.8)
 Depth: 2-1/2 (6.4)
 Height: 8-1/8 (20.6)
 Weight: 4.1 lbs (1.9 kg)

All dimensions are inches (centimeters) unless otherwise indicated.



WLTE

EMERGENCY: One Lithonia Way Conyers, GA 30012 Phone: 800-334-8694 techsupport-emergency@acuitybrands.com www.lithonia.com © 2012-2018 Acuity Brands Lighting, Inc. All rights reserved. Rev. 09/20/2018