



Oakland Housing
Authority

February 9, 2021

Gentlemen/Ladies:

SUBJECT: IFB No. 21-005 Boardroom Audio Visual Renovations

The Oakland Housing Authority (“the Authority”) invites bids for Audio Visual Contractors for renovating the Audio Video technology in the Oakland Housing Authority’s Boardroom.

Proposals will be accepted online through the Housing Agency Marketplace until 10:00 a.m. (local time) on March 4, 2021. Bids received after 10:00 a.m. on March 4, 2021 will be rejected without consideration.

Questions of a procedural nature may be directed to Jeanne Smith at (510) 587-2123.

We look forward to receiving your bid.

Sincerely,

DocuSigned by:

Patricia Wells

722CF180EE194A1...

Patricia Wells

Executive Director

Oakland Housing Authority

1619 Harrison Street, Oakland, CA 94612



Oakland Housing
Authority

INVITATION FOR BIDS (IFB)

IFB # 21-005

Boardroom Audio Visual Renovation

IFB Issued:	February 9, 2021
Pre-Proposal Conference: (non-mandatory)	February 23, 2021 @ 9:00 AM through Zoom
Walk Through: (non-mandatory)	February 23, 2021 @ 10:00 AM Location: 1619 Harrison Street, 1 st Floor Oakland CA 94612
Questions Due	February 25, 2021 by 10:00 AM (Pacific Time)
Email Questions To:	ccgs@oakha.org (Indicate above RFP #21-005 in "Subject")
Addendum Issued: (if applicable)	March 2, 2021 (Posted on the Authority's website and Housing Agency Marketplace)
Bids Due:	March 4, 2021 @ 10:00 AM (Pacific Time) <u>Proposers MUST register with Housing Agency Marketplace in order to submit a proposal.</u>

Contract Compliance & General Services (CCGS) Department
Oakland Housing Authority
1619 Harrison Street, Second Floor, Oakland, CA 94612
e-mail: CCGS@oakha.org

Contact person for the above IFB: [Jeanne Smith, Contract Specialist](mailto:Jeanne.Smith@oakha.org)
Email: CCGS@Oakha.org

Oakland Housing Authority

INVITATION FOR BIDS (IFB) IFB # 21-005

Documents (in the order of the IFB package)		MUST be submitted with Bid.
TABLE OF CONTENTS		
1.	General Information.....4	
2.	Scope of Work.....5	
3.	Bid Process.....5	
4.	Bid Submission Requirements.....7	
5.	Bid Opening.....9	
6.	Contract Award..... 10	
7.	Notice to Proceed.....12	
8.	Deliverables.....13	
9.	Payment.....13	
Minimum Requirements to be submitted with Bid		
	Bid Form	√
	Contractor's Project Schedule with milestones (Bidder generated)	√
	A bid guarantee in accordance with HUD-5369, section 9 must be provided for projects over \$25,000.00. <i>Bid guarantee must <u>be not less than 5% of total bid.</u> Failure to provide will result in your bid being <u>disqualified.</u></i>	√
	License C-7 and /or C-10	√
ATTACHMENTS (FORMS/DOCUMENTS)		
A.	Work Scope and AV Equipment List	
B.	Bid Form	√
C.	Qualifications Statement	√
D.	Profile and Certification Form	√
E.	Section 3 Business Certification and Action Plan	√
F.	Subcontractor Form	√

Documents (in the order of the IFB package)		MUST be submitted with Bid.
G.	Asbestos Notice to Contractors and Acknowledgement Form	√
H.	U.S. Department of Housing and Urban Development – Representations, Certifications, and Other Statements of Bidders (Form HUD-5369-A)	√
I.	Addendum Acknowledgement – To be posted on Website if applicable.	√
J.	Oakland Housing Authority Economic Opportunities Policy – Section 3 Requirements	
K.	Contractor's Summary Guide to Section 3 Compliance	
L.	U.S. Department of Housing and Urban Development – Instructions to bidders for Contracts – Public and Indian Housing Projects (Form HUD-5369)	
M.	U.S. Department of Housing and Urban Development – General Conditions of the Contract for Construction (Form HUD-5370)	
N.	OHA Insurance Requirements for Contractors	
O.	Vendor Protests And Claims Procedures	
P.	Wage Determination - Davis-Bacon Wage Decision (<i>Use this as part of the cost calculation.</i>)	Decision CA20210018

1. **GENERAL INFORMATION**

IFB Introduction: The Oakland Housing Authority (“Authority”) invites interested licensed Audio Visual Contractors to submit bids to this Invitation to Bid (IFB) for provide all labor, materials, tools, equipment, supervision, associated insurance, licenses and permits required to update the audio visual capabilities in the Oakland Housing Authority Boardroom.

In keeping with its mandate to provide efficient and effective services, the Oakland Housing Authority is now soliciting bids from qualified, licensed and insured entities to provide the above noted services to the Authority. All bids submitted in response to this solicitation must conform to all of the requirements and specifications outlined within this document and any designated attachments in its entirety.

For further information and/or updates on this bid or any other Authority projects, you may go to the OHA website at www.oakha.org. Select “Business Opportunities”, “Procurement”, “Current Bid Openings” and “Active Bids”.

Oakland Housing Authority Reservation of Rights:

The Authority reserves the right to reject any or all bids, to waive any informality in the IFB process, or to terminate the IFB process at any time, if deemed by OHA to be in its best interests.

- The Authority reserves the right not to award a contract pursuant to this IFB.
- The Authority reserves the right to terminate a contract awarded pursuant to this IFB, at any time for its convenience.
- The Authority reserves the right to determine the days, hours and locations that the successful proposer(s) shall provide the services called for in this IFB.
- The Authority reserves the right to negotiate the fees proposed by the proposer entity.
- The Authority reserves the right to reject and not consider any bid or bidder that does not meet the requirements of this IFB, including but not necessarily limited to incomplete bids and/or bids offering alternate or non-requested services.
- The Authority has no obligation to compensate any bidder for any cost incurred in responding to this IFB.
- The Authority reserves the right to, at any time during the IFB or contract process, to prohibit any further participation by a proposer or reject any proposal submitted that does not conform to any of the requirements detailed herein. By accessing and/or by downloading this document, each prospective proposer is thereby agreeing to abide by all terms and conditions listed within this document, and further agrees that he/she will inform the CCGS Contact Person in writing within 5 days of the discovery of any item listed herein or of any item that is issued

thereafter by the Authority that he/she feels needs to be addressed. Failure to abide by this time frame shall relieve the Authority, but not the prospective proposer, of any responsibility pertaining to such issue.

The Authority Information

The Oakland Housing Authority was established in 1938 to assure the availability of quality housing for low-income persons. The Authority operates federally funded and other low-income housing programs and assists over 16,000 of Oakland's lowest-income families, elderly and persons with disabilities. The Authority serves and embodies a diverse community; therefore, it is crucial that contractors understand the effects of race, class, ethnicity, income, and other issues of difference in our society, and display a high level of cultural competency throughout their interactions with the Authority.

The mission of the Oakland Housing Authority is:

To assure the availability of quality housing for low-income persons and to promote the civic involvement and economic self-sufficiency of residents and to further the expansion of affordable housing within Oakland.

OHA also has a goal of promoting growth and development of small businesses (which includes minority, women-owned and veteran-owned firms). OHA is committed to having a diversified vendor base. Thus, OHA requires vendors to "undertake good faith efforts to ensure that Minority Business Enterprises and Woman Business Enterprises are provided opportunities to contract with the Authority for the delivery of goods and services." Please refer to the Profile and Certification form for further details.

2. SCOPE OF WORK

Oakland Housing Authority is seeking bids from qualified, licensed and bonded entities to provide the requested services. It is expected that the scope of services under any contract awarded pursuant to this IFB will include the services described in Exhibit A and may include tasks or services described in sub categories of this IFB. The Contractor may provide the following services, but not necessarily be limited to the scope of work contained in this IFB (see attached "**Scope of Work**" in Exhibit A).

Subcontractors

The selected Contractor may require the services of sub-contractors. The Authority will reserve the right to audit the financial records of the contractors and its sub-contractors. (Please submit the **Sub-Contractor Form** in the attached forms *if applicable*).

3. BID PROCESS

Pre-bid Conference and Walk-through:

The scheduled pre-bid conference is, pursuant to HUD regulation, not mandatory. Many prospective bidders have previously responded to an IFB and feel comfortable in doing so without attending the pre-conference. Typically, such conferences last one hour or

less, though such is not guaranteed. The purpose of this conference is to assist prospective bidders to have a full understanding of the IFB documents so that they feel confident in submitting an appropriate bid; therefore, at this conference OHA will conduct a brief overview of the IFB documents, including the attachments. Prospective bidders may also ask questions, though the Contracting Officer (CO) may require that some such questions are delivered in writing by the specified deadline for questions prior to a response being delivered. Whereas the purpose of this conference is to review the IFB documents, attendees should bring a copy of the IFB documents to this conference; OHA may or may not distribute at this conference any copies of the IFB documents. To join the Zoom call for the Pre-Bid Conference use link below:

<https://oakha-org.zoom.us/j/99928830907?pwd=ek00R1VuWGRuWGYwQmpaSXRBSHFhQT09>

Meeting ID: 999 2883 0907

Passcode: 912689

One tap mobile

+16699009128,,99928830907#,,,,*912689# US (San Jose)

+12133388477,,99928830907#,,,,*912689# US (Los Angeles)

There will be an in person walk-through at the project location for this IFB at 1619 Harrison Street, Oakland CA 94612 on February 23, 2021 starting at 10:00AM after the pre-bid conference. Please contact Jeanne Smith to schedule appointment. Appointments will be 15 minutes per contractor with 15 minutes in between each appointment and masks and social distancing are mandatory

Questions:

All questions must be submitted in writing no later than the specified date and time on the cover via email to:

E-mail address: CCGS@oakha.org (Please indicate the IFB# in the "Subject")

No questions will be responded to after the question and answer period has expired.

Addendum:

All questions will be answered and responded to in writing by the specified date on the cover. The addendum will be posted on the OHA Vendor Center website at www.oakha.org. Select "Business Opportunities", "Procurement", "Current Bid Openings", "Active Bids", and select the desired bid # as well as Housing Agency Marketplace if applicable at the below link:

https://ha.economicengine.com/requests.html?company_id=50863/

During the IFB solicitation process, the CO will NOT conduct any *ex parte* (substantive) conversation. "Substantive" meaning, when discussions pertaining to the IFB are made between OHA and a prospective bidder and other prospective bidders are not present, the conversation may give one prospective bidder an advantage over other prospective bidders. This does not mean that prospective bidders may not call the CO; it simply means that, other than making replies to direct the prospective bidders where his/her

answer has already been issued within the solicitation documents, the CO may not respond to the prospective bidder's inquiries but will direct him/her to submit such inquiry in writing so that the CO may more fairly respond to all prospective bidders in writing by addendum.

4. BID SUBMISSION REQUIREMENTS

It shall be the responsibility of each bidder to be aware of and to abide by all dates, times, conditions, requirements and specifications set forth within all applicable documents issued by OHA, including the IFB document, the documents listed within the following section, and any addenda and required attachments submitted by the bidder. By virtue of completing, signing and submitting the completed documents, the bidder is stating his/her agreement to comply with the all conditions and requirements set forth within those documents. Written notice from the bidder not authorized in writing by the CO to exclude any of the OHA requirements contained within the documents may cause that bidder to not be considered for award.

So that OHA can properly evaluate the offers received, all bids submitted in response to this IFB must be formatted in accordance with the following guidelines:

The following items must be submitted with your bid in the following order:

Minimum Requirements to be submitted with bid:

- A. Completed Bid Form
- B. Contractor's Project Schedule (Bidder generated) – Include milestones
- C. Copy of State of California Contractor License – C-7 and/or C-10
- D. Bid Bond of 5% of Bid Amount if greater than or equal to \$25,000.

Required Forms / Documents (under "Attachments" section):

- A. Qualifications Statement
- B. Profile and Certification Form
The form must be completed and signed.
- C. Section 3 Business Certification and Action Plan
The **Section 3 Certification and Action Plan** attached must be completed and signed.

OHA expects the selected firm to comply with the Section 3 policy. Refer to Attachment **"Section 3 Requirements - Oakland Housing Authority Economic Opportunities Policy"** in this IFB. The firm(s) must describe proposed compliance with Section 3 of the Housing Act of 1968, as amended regarding the provision of training and employment opportunities for low-income persons, with priority to residents of OHA public housing.

The OHA Project Manager and Contract Compliance staff will monitor the Contractor's compliance with Section 3 requirements.

D. Subcontractor Form

The Subcontractor Form must be completed to identify the tasks performed by Contractor and if applicable, subcontractor(s).

E. Asbestos Notice to Contractors and Acknowledgement Form

F. HUD Form 5369-A

Bidder must complete the U.S. Department of Housing and Urban Development – Representations, Certifications, and Other Statements of Bidders (Form **HUD-5369-A**) form furnished in this IFB.

G. Addendum Acknowledgement Form (if applicable)

All applicable addendum acknowledgement form(s) must be submitted with the bid.

Locating Applicable Wage Rates:

As the currently known work pertaining to this IFB is construction-related, OHA is required to pay Davis-Bacon wage rates (for all “construction contracts in excess of \$2,000”), and for similar State requirements, OHA will then issue a General Decision as it applies to that work. Current Davis-Bacon wages rates are included in this bid package. The wages may also be accessed by going to:

<http://www.wdol.gov/dba.aspx#0> / Select California (state), Alameda (County), Residential (Construction Type).

Important Note: The wage determination is subject to change depending on the time frame between the deadline of the bid date and the date of the Purchase Order/Notice to Proceed.

Bid Submission:

Responses to this IFB will be accepted online at the Housing Agency Marketplace website at ha.economicengine.com until 10:00 AM (PST) on Thursday, March 4, 2021.

Proposers MUST register with Housing Agency Marketplace at the following link in order to submit a proposal.

https://ha.economicengine.com/requests.html?company_id=50863

Please do not wait until the last minute to submit proposal, as it may take time to upload your proposal. To attach documents to your response, open the solicitation, and check the gray box near the bottom of the solicitation that says “Responder Will Bid”, or in some cases, “Respond to this Bid Online”. Be sure to review the total response to make sure this is exactly what you want to submit. Once review is complete, click on the “Confirm Response” link and you will get a confirmation number/letters at the top of the page. Vendors are able to revise this response at any time prior to the solicitation deadline by logging in, clicking on the title of the solicitation/ View Response/ Revise Response.

If you have any technical issues with the Housing Agency Marketplace website or questions regarding the process, please contact Larry Hancock at 1-866-526-0160 or the general support line at 1-866-526-9266.

Late proposals will not be considered.

The Authority will not provide any reimbursement for the cost of developing, presenting or providing any response to this IFB.

Submission Conditions:

DO NOT MAKE ANY ADDITIONAL MARKS, NOTATIONS OR REQUIREMENTS ON THE DOCUMENTS TO BE SUBMITTED. Bidders are not allowed to change any requirements or forms contained herein, and if any additional marks, notations or requirements are entered on any of the documents, that bid may be invalidated. If, after accepting such a bid, OHA decides that any entry has not changed the intent of the bid that OHA received, OHA may accept the bid and the bid shall be considered as if those additional marks, notations or requirements were not entered. By accessing the noted Internet system, registering and downloading these documents, each prospective bidder that does so is thereby agreeing to confirm all notices that OHA delivers to him/her as instructed, and by submitting a bid, the bidder is thereby agreeing to abide by all terms and conditions published herein and by addendum pertaining to this IFB.

Bidder's Responsibilities—Contact with the OHA:

It is the responsibility of the bidder to address all communication and correspondence pertaining to this IFB process to the CO only. Bidders must comply with the requirements set forth in the IFB documents and/or any applicable addendum in writing.

5. BID OPENING

Public Opening:

Due to Covid-19, all bids will be opened on a Zoom call on March 4, 2021 at 11am. To Join the Zoom Meeting use link below:

<https://oakhaorg.zoom.us/j/92495032901?pwd=VjZQZlVvdKxqdnhJQWpod0tJaENWUT09>

Meeting ID: 924 9503 2901

Passcode: 523417

One tap mobile

+16692192599,,92495032901#,,,,*523417# US (San Jose)

+16699009128,,92495032901#,,,,*523417# US (San Jose)

All bids received will be opened and publicly read aloud by the CO, including the company name of the bidder and the lump sum cost proposed. At the bid opening OHA will only disclose the following information: (a) The company name of each bidder; (b) the total amount bid; and (c) the identity of the apparent low bidder. A copy of the bid tabulation or recap recorded may be made available to each member of the public attending such opening and to anyone who requests such afterwards. The bids will not be made available for inspection by anyone at this time; OHA will, at a later time, review all bids in detail and will, in a timely manner, notify any bidder ruled to be non-responsive

or not-responsible (as detailed within Section 8(d) of form HUD-5369 and Section 7(b)(3) of form HUD-5369-B). OHA reserves the right to waive informalities and minor irregularities in the offers received. The results shall be posted on the OHA Vendor Center website at www.oakha.org/ Select Procurement/ OHA Vendor Center/ Current Bid Opportunities / Select the desired Bid#. Bids will be available for inspection by the public after the award has been completed. (In the case of ties, the award shall be decided as detailed within Section 6.12.C of HUD Procurement Handbook 7460.8 REV 2, by “drawing lots or other random means of selection”).

Responsive Evaluation:

After the public opening the “hard copy” bid submittals received will be evaluated in private for responsiveness (i.e. meets the minimum of the requirements). Firms not meeting the minimum and are deemed to be non-responsive will be notified in writing by OHA in a timely manner.

Responsible Evaluation:

OHA will evaluate the apparent lowest responsive bidder to ensure that he/she is responsible (i.e. a firm that is qualified, responsible and able to provide to the Authority the required services). If OHA ascertains that the firm has the required ability, capability, experience, knowledge, licensing, insurance and resources to provide the required services, OHA may proceed with award. If OHA determines that the firm is deemed to be not responsible, the firm will be notified in writing in a timely manner. OHA will then proceed with the next lowest bidder.

Depending on the amount of the award (typically for awards greater than \$50,000), OHA may take such contract award to OHA Board of Commissioners (BOC) for approval of the award prior to executing a contract with the apparent successful bidder.

6. CONTRACT AWARD

Lowest Responsive and Responsible Bidder:

Award of an IFB is made to the responsive and responsible bidder that submits the lowest bid/cost.

Contract Award Procedure:

If a contract is awarded pursuant to this IFB, the following detailed procedures will be followed:

- The selected Contractor will receive a Purchase Order/Contract. For contract amounts above \$150,000, Board approval must be obtained. Therefore, there may be a period of time between the bid due date and issuance of the Purchase Order. Work may NOT commence without a Purchase Order and Notice to Proceed, (see “*Notice to Proceed*” section below).
- By completing, executing and submitting the Bid Form and required documents, the bidder is thereby agreeing to “abide by all terms and conditions pertaining to this IFB as issued by OHA, either in hard copy or on the noted Internet system, including any applicable contract agreement. Accordingly, OHA has no responsibility to conduct after the submittal deadline any negotiations pertaining to

the contract clauses already published; and in any case OHA has no power or authority to negotiate any clauses contained within any attached HUD documents.

Contract Terms and Conditions:

The following provisions are considered mandatory conditions of any contract award made by the OHA pursuant to this IFB:

Contract Form: As the work is funded with U.S. Department of Housing and Urban Development (HUD) funds, the contract must comply with all applicable HUD requirements specified in HUD-5370 General Conditions for Construction Contracts. The Contractor must also comply with all Authority requirements as applicable based on contract size which will be incorporated into any contracts awarded.

OHA will not execute a contract solely on the successful bidder's form. Contracts will only be executed on the required OHA and/or HUD forms, and by submitting a bid the successful bidder agrees to do so (please note that OHA reserves the right to amend the form(s) as deemed necessary). However, OHA will, during the IFB process, (prior to the submittal deadline) consider any contract clauses that the bidder wishes to include therein and submits in writing a request to do so. Failure of OHA to include such clauses does not give the successful bidder the right to refuse to execute OHA's contract form. It is the responsibility of each prospective bidder to notify OHA, in writing, prior to submitting a bid, of any contract clause that he/she is not willing to include in the final executed contract and abide by. OHA will consider and respond to such written correspondence, and if the prospective bidder is not willing to abide by OHA's response (decision), then that prospective bidder's bid shall be deemed non-responsive.

Workmanship Warranty: The Contractor shall warrant that the work performed will conform to the contract requirements, industry standards, and manufacturer product standards for a period of two (2) years from the final acceptance of the work. The contractor shall remedy, at the contractor's expense, any failure to conform, or any defect of equipment or workmanship furnished by the Contractor. Failure to correct the defect will result in the Contractor being determined to be "non-responsible" and may be disqualified by OHA for future projects.

Warranty/Guarantee: All work provided shall be warranted or guaranteed by the Contractor for a period of time of not less than two (2) years from the final acceptance of work.

Assignment of Personnel:

OHA shall retain the right to demand and receive a change in personnel assigned to the work if OHA believes that such change is in its best interest and the completion of the contracted work.

Unauthorized Sub-Contracting Prohibited:

The successful bidder shall not assign any right, nor delegate any duty for the work proposed pursuant to this IFB (including, but not limited to, selling or transferring the contract) without the prior written consent of the CO. Any purported assignment of interest or delegation of duty, without prior written consent of the CO shall be void and may result in the cancellation of the contract with OHA, or may result in the full or partial

forfeiture of funds paid to the successful bidder as a result of the proposed contract; either as determined by the CO.

Licensing and Insurance Requirements:

Prior to award (but not as a part of the bid submission) the *successful bidder* will be required to provide:

- An original certificate evidencing the bidder's appropriate licensing current industrial (worker's compensation) insurance carrier and coverage amount;
- Insurance certificates evidencing all applicable insurance requirements as specified in "OHA's Insurance Requirements for Contractors".
- A copy of the bidder's business license allowing that entity to provide such services within the appropriate jurisdiction (State of California).
- A copy of the bidder's license issued by the State of California licensing authority allowing the bidder to provide the services detailed herein such as the Specialty Contractor license classification.

Contract Service Standards:

All work performed pursuant to this IFB must conform and comply with all applicable local, state and federal codes, statutes, laws and regulations.

7. NOTICE TO PROCEED

Upon receipt of the Purchase Order, the Contractor will meet with the Project Manager and the OHA Labor Compliance Specialist prior to commencing any site work. The Contractor shall not start any project without an approved and signed Purchase Order and "Notice to Proceed" from the Project Manager. The following documents and/or process will be required prior to obtaining a Purchase Order and Notice to Proceed (if applicable):

1. Insurance Requirements: OHA will require the selected Contractor to meet statutory insurance requirements and provide proof of insurance in accordance with HUD-5370 as applicable, depending on the size of the contract.
2. Performance & Payment Bond: OHA will require the selected Contractor to provide a performance/payment bond (either 20% of the total bid amount in the form of a cashier's check or 100% of the total bid amount issued by approved surety bonding company).
3. Prevailing Wage Requirement: The OHA Labor Compliance Specialist will determine the appropriate wage rate based on the scope of work for the project. The Contractor will meet with the OHA Labor Compliance Specialist for instruction on labor compliance.

4. Weekly Certified Payroll: Certified Payrolls must be forwarded to the OHA Labor Compliance Specialist. OHA will conduct site interviews of employees to verify wages. Any classification not listed will require a formal request for the wage determination, which will be submitted to HUD by the OHA CCGS Department.
5. Section 3 Reports: Section 3 Reports, if applicable, must be submitted to the CCGS Department on a monthly basis.
6. Subcontractor Form: The Subcontractor List Form (refer to Attachments) must be submitted.
7. Form HUD 5369-A: If not already submitted.
8. Asbestos Notice to Contractors and Acknowledgement Form: If not already submitted.
9. Any Other Applicable Required Documents.

8. DELIVERABLES/SCHEDULE

Expected deliverables and due dates that have to be committed to:

Submittal package due: 6 weeks after NTP.

Construction Start: 3 months after NTP.

Construction Substantial Completion: 5 months after NTP.

9. PAYMENT

All invoices to Authority shall be itemized, with each installment to be on a separate bill. Bills shall be itemized in the following manner:

1. Identify invoice period (example: Jan 1, XX18 to Jan 30, XX18)
2. Identify bid # and address
3. Indicate purchase order number
4. Attach Schedule of Values
5. Unconditional lien releases (for all materials and subs) – starting a billing #2 for the previous billing.

Appendix A
Scope of Work
And
AV Equipment List

SECTION 27 41 17**PRODUCTION AV SYSTEMS**

PART 1 - GENERAL**1.1 SUMMARY:**

- A. Section Includes: Services as listed herein and related to the furnishing, installation, and commissioning of audio, video and communications equipment.
- B. Related Documents: The Conditions of the Contract and Division 01 – General Requirements apply to this section as fully as if repeated herein.
- C. Related Sections: Coordinate with the following sections in carrying out this work:
 - 1. Division 26 – Electrical
- D. Line-Item Cost breakdown
 - 1. Provide line-item cost breakdown as referenced in the equipment list, an appendix to this section.
- E. Service Level Agreement
 - 1. Provide line-item cost for SLA as referenced in this section.

1.2 REFERENCES:

- A. Comply with all national, state and local regulations and the procedures and requirements of the local authorities. In the event of conflict between these specifications and the applicable regulations, the more stringent shall govern.
 - 1. Codes:
 - a. California Building Code (CBC)
 - b. California Electric Code (CEC)
 - c. National Electric Code (NEC)
 - 2. Standards & Organizations:
 - a. National Fire Protection Association (NFPA)
 - b. Federal Communications Commission (FCC)
 - c. ANSI American National Standards Institute
 - d. ASA American Standards Association
 - e. ASTM American Society for Testing Materials
 - f. EIA/TIA Electronic Industries Association/Telecommunications Industries Association
 - g. ETL Electrical Testing Laboratories
 - h. ISO International Standards Organization

- i. NEMA National Electrical Manufacturer's Association
 - j. UL Underwriter's Laboratories
 - k. ESTA Entertainment Services and Technology Association
- B. Equipment shall be provided in accordance with the related trade and regulatory guidelines including but not limited to UL, NEC, IEEE, and all manufacturer's recommendations and requirements. Contractor shall be responsible in the event that work under their control voids or jeopardizes manufacturers' warranties.
- C. Labor shall be provided in accordance with applicable labor regulations and practices.

1.3 DEFINITIONS:

- A. Refer to the General Conditions for definitions.
- B. Architect: For the scope in this Section, authorized personnel representing the Oakland Housing Authority ("the Authority") and the AV Consultant.

1.4 SYSTEM DESCRIPTION:

- A. General
 - 1. Several pieces of existing equipment will be reused. See the equipment list for a complete listing.
 - 2. Remove and turn over items slated for demolition to the Authority.
- B. Board Room
 - 1. Audio Systems
 - a. The reinforcement audio system is comprised of an automatic mixer system with automatic echo cancellation, and integrated VOIP hybrid.
 - b. The internal programming of the DSP is under the scope of this work and shall be submitted for approval during the shop drawing process. The contractor is responsible to provide standard & customary DSP blocks, including necessary EQ, protection limiting, etc.
 - c. Connect to the existing VOIP system and coordinate with the Authority's IT forces for complete configuration. The clerk should be able to make & receive calls using the VOIP system and the in-room microphones & speakers. Provide dialing and volume controls as are typical & customary.
 - d. Two channels of wireless microphone shall be provided, complete rechargeable batteries, drop-in chargers, remote antennas, and antenna combiner.
 - e. The loudspeaker system is comprised of zoned ceiling-mounted speakers and a network-based multi-channel amplifier.
 - f. A conferencing/discussion system shall be provided, with both delegate and chairman units. The system shall support remote microphone control, request-to-speak queuing, and interface to third party controls for individual microphone control.
 - 1) Configure all units with push-to-talk (latching).
 - 2) Each conferencing unit shall have a pluggable microphone.

- 3) Configure the unit on the control network.
 - 4) Provide training as indicated in the specifications.
- g. At the public lectern, a microphone with on/off indicator shall be provided. On/off control shall be available at clerk and control booth touchpanels.
 - h. All functions necessary to operate a meeting shall be accessible from the touchpanels located at the video control suite and the clerk's position at the dais.
 - i. An audio and data patchbay and patchcords shall be provided.
2. Assistive Listening
 - a. Reuse the existing IR-based assistive listening system. Connect complete.
3. Video Systems- Presentation
 - a. An IP-based production video switching, routing and KVM system with scaling shall be provided to handle signals from all video devices. All input and output devices shall use CAT6A/STP cable as the means of transport to the AV rack room, where the ethernet switch is located. The switcher shall be fully HDCP compliant and support EDID.
 - 1) It is within the scope of this project to completely define and configure the EDID table. The presentation system shall operate at 1920x1080p natively, without scaling.
 - 2) A server appliance to enable configuration and video switching for the entire system shall be provided and configured appropriately.
 - 3) Audio from the IP-based switching system shall be fed to the audio DSP via DANTE/AES67 protocol.
 - b. A CATV tuner shall be provided by Authority for utility viewing at the equipment rack.
 - c. One video projector shall be provided with a zoom lens. Locate the projector so the zoom is between extents. Reuse existing projector lift and connect complete.
 - d. Reuse existing motorized roll-down screen. Connect complete.
 - e. Two 86" LCD flat panel main displays shall be ceiling-mounted at locations indicated in the drawings.
 - f. A flat-panel LCD display shall be provided at each dais and staff position for viewing by board members and staff. The displays shall be attached to articulating arms, so viewers may adjust displays as needed. Provide ample power & video signal cable to allow full range of movement. Cable shall be routed internal to the mount and dressed in an aesthetically pleasing manner. Signal shall be fed to the monitors via HDMI distribution amplifiers located under the dais.
 - g. A 65" LCD flat panel display shall be wall mounted in the meeting room. Provide audio, mounting and control devices per the equipment list.
 - 1) A complete Zoom room system shall be provided as indicated in the equipment list.
 - 2) Coordinate with Authority's IT forces for Zoom configuration.

- h. At dais & staff, provide (2) flip-top units with connections as shown in the equipment list, as well as (11) USB/120V power units. Provide at locations shown in the drawings.
 - i. At presenter's podium, provide one microphone with LED indicator. Configure complete.
 - j. Provide color-coded cable connections at both cable-end and connector panel.
4. Broadcast Systems
- a. An HD-SDI broadcast-style production video switcher with integrated multiviewer and CG software shall be provided with all accessories as shown in the equipment list and in the drawings.
 - b. The video switcher shall be configured and programmed to be fully operable, and be delivered in a "turn-key" manner.
 - c. A 15" LCD monitor shall be provided for use with the switcher's program outputs.
 - d. Provide a complete management and control suite, suitable for public-government broadcast. The system shall use a touchpanel monitor with control information overlaid on multiviewer video feeds.
 - 1) Coordinate with manufacturer to setup and configure the GUI and associated systems.
 - e. Provide a complete CG system and integrate into the switcher/router system as needed. Provide monitor/key/mouse with control via KVM.
 - f. Provide signal processing, sync and DA units as indicated.
 - g. A digital audio mixer with Dante connection shall be provided, along with audio monitor and accessories.
 - h. Provide (4) 3G-SDI pan/tilt/zoom cameras. Provide wall/ceiling mount bracket, remote power supply and install complete. The units shall be controlled from the switcher.
 - i. Connect a downscaled SDI feed with embedded audio from the router to the (e) Granicus encoder and confirm proper operation with technical personnel.
 - j. Provide one SD-card-based rack mount recorder. Connect input/output to the router, and provide additional media and docks as indicated.
 - k. Provide soft-codec interfaces and computer for soft-codec integration with the system.
 - l. Manufacturer training & setup time shall be provided as part of this scope.
 - m. Extended warranties shall be provided as indicated.
5. Program Monitor
- a. For program monitoring at booth and meeting rooms, reuse existing ceiling speakers and volume controls. The system shall be fed from program audio in the chambers
6. Control System
- a. A touch screen based control system shall be provided for control over all applicable AV devices.

- b. Color touchscreens with table base shall be provided at the control booth and the clerk's position at the dais.
 - c. A mute light shall be provided at the ceiling, with "MICS MUTED" engraving. The light shall illuminate RED when the mics are muted on the touchpanel.
 - d. Provide a dedicated gigabit Power-Over-Ethernet switch for control system use.
 - e. All control system programming is the responsibility of the AV contractor, and shall be submitted during the shop drawing phase for approval. See control system section below.
7. Public Speaker Timer
- a. Provide a public speaker timing system, complete with clock/signal units. The master control device shall be located at the clerks' station.
 - b. A central power supply shall be located in the AV equipment rack. Follow all manufacturer recommendations for connection and configuration.
8. Informacast Integration
- a. Install Authority-furnished Informacast network appliance and connect complete as shown on the drawings.
 - b. During a mass notification event, configure the control system, using the Informacast API, to turn on and switch all displays to show the Informacast information. Likewise with audio, configure the audio system power and routing to send the Informacast audio through all speakers.
 - c. When an Informacast event is active, the touchpanel shall display a notification that the mass notification is active, with the ability to override using a passcode.
 - d. Coordinate with Authority IT personnel for configuration.
9. Utility/General
- a. Provide stamped, engineered structural drawings for all mounting assemblies.
 - b. Equipment racks shall be provided at locations shown on the drawings. Provide additional rack accessories as indicated in part two below.
 - c. For power management at equipment racks, in-rack outlet raceways and existing sequencer shall be provided.
 - d. UPS units shall be provided at the AV equipment rack and the control booth. Connect processor-based devices to the UPS unit.
 - e. Provide and install new fire-rated poke-thru floor pocket. The entire installation, including core drilling the concrete, scanning concrete, fire seal, cleanup, etc, is under the scope of this section. Lid finish to be determined during the submittal phase.
 - f. Provide all required mounting hardware.
10. Control System Programming
- a. Touchpanels shall be configured with the most often-used device functions. Do not attempt to put every possible device function on the touchpanel.

- b. The touchpanel shall be configured to work in two modes: Board Meeting and Community Room.
- c. Provide the following minimum feature set at the control booth touch panel (master control):
 - 1) System Power On/Off
 - 2) Automixer, Wireless Mics, Dias Mics, Video Source & Main System Volume
 - 3) Audio break away with select or audio-follows-video mode
 - 4) Individual microphone mutes for dias, staff and podium positions
 - 5) Voting results controls
 - 6) MUTE light manual override
 - 7) Projector On/Off & mute
 - 8) Projection Screen Up/Down/Stop
 - 9) LCD Screens On/Off & mute, input select
 - 10) Matrix Switcher controls (source, routing)
 - 11) Audio controls from audio DSP to broadcast system
 - 12) Audio conference controls (dialer, speed dial, all volume controls)
- d. Provide the following minimum feature set at the clerk's touch screen panel:
 - 1) System Power On/Off
 - 2) Wireless Mics, Dias Mics, Public Podium Mic, Video Source & Main System Volume
 - 3) Audio conference controls (dialer, all volume controls)
 - 4) Voting results controls
 - 5) Individual microphone mutes for dais, staff and podium positions
 - 6) Projector n/Off & mute
 - 7) Projection Screen Up/Down/Stop
 - 8) LCD Screens On/Off & mute, input select
 - 9) Matrix Switcher controls (source, routing)
- e. Provide (4) Macro command buttons on main page, to be determined by Authority during the submittal period. Macros may include: "board meeting", "watch movie", "staff presentation" or similar.
- f. Touchpanel programming is the responsibility of the contractor. An outline has been made above, but does not include all functions required. The contractor is responsible to design a graphic user interface using the following guidelines:
 - 1) In automatic mode, use must be able to complete any function within two button presses.
 - 2) More important functions shall be more prominent on the interface.
 - 3) Like functions shall appear at the same place on every screen.
 - 4) Nesting menus are not allowed.
- g. The base template for the touchpanel shall be from the stock manufacturer line, with customization as necessary. The template colors shall be modified to match organization colors, and the splash screen shall show the organization's logo.

C. FFE/Loose Equipment

1. Provide portable equipment as listed in the equipment list.
2. On all loose cables, provide a color heatshrink label or engraved shell reading "Oakland Housing Authority", and an affixed Velcro cable tie. Color of heatshrink or connector boot shall determine length. Patchcords need not be labeled. Use the following color scheme:
 - a. 10' or less: White
 - b. 25': Orange
 - c. 50': Green
 - d. 100': Red

D. Service Level Agreement (SLA)

1. Provide a 1-year service level agreement (SLA) with the following:
 - a. Unlimited remote helpdesk support from 7am to midnight.
 - b. Preventative maintenance visits (quarterly)
 - c. Loaner equipment during repair period
 - d. Emergency/Priority response service call option (added cost, per occurrence)
2. Provide option to extend the SLA on a yearly basis.

1.5 CURRENT TECHNOLOGY:

- A. Only the most current hardware and software shall be provided. In no case will discontinued or superseded products be acceptable. If the manufacturer has developed and successfully released products that meet or exceed the criteria within this specification, the Contractor shall notify the Architect and submit the new product for review. If accepted, the products shall be provided at no additional cost to the Authority. Software upgrades and authorized support services for its proper integration into the system shall be provided at no cost to the Authority throughout the warranty period.
- B. In the event of known product defaults or recall, the Contractor shall immediately notify the Architect and make immediate arrangements for remedy.
- C. None of the stipulations herein shall be grounds for revision to the Project schedule.
- D. See related procedures under Warranties in this Section.

1.6 SUBSTITUTIONS:

- A. All requests for substitutions from the specified materials, assemblies or related services shall be submitted for review by Architect in accordance with Section 01. Requests shall be made in a timely fashion so as to not affect the Project schedule in either case of the substitution being accepted or rejected.

- B. Documentation for the substitution shall be submitted with supporting material and shall including the related information for the item as specified so that equivalence can be demonstrated. The burden of proof rests solely upon the Contractor. The Architect shall be the sole evaluator of the fitness of the substitution.
- C. All expenses related to the substitution including, but not be limited to, all fees and expenses incurred in the evaluation of the substitution, and any effect on the costs and schedule of other trades whether or not the substitution is accepted, shall be borne by the Contractor.

1.7 SUBMITTALS

A. General:

- 1. If permitted under Section 01– Submittal Procedures, all submittals shall be made in electronic format.
 - a. Files shall be in .pdf format and submitted via CD or DVD.
 - b. Clearly indicate submittal number and description in the file name of the document.
 - c. Each document shall be a separate file.
 - d. Markups will be made electronically, and the submittal returned via electronic means.
- 2. Submittals shall be made in a timely fashion so as to not affect the Project schedule and shall allow for adequate time for review and resubmittal. Partial submittals will not be acceptable and will be returned without review.
- 3. Submittals shall be reviewed, and field dimensions verified, prior to commencing acquisition for, and fabrication of the Work in this section. All services and parts of the work in this section shall be verified through the submittal process.
- 4. Acceptance of any submitted data or shop drawings for material, equipment, apparatus, devices, arrangement and layout shall not relieve contractor from responsibility of furnishing same of proper dimensions and weight, capacities, sizes, quantity, and installation details to perform efficiently the requirements and intents of the systems design. Such acceptance shall not relieve the contractor from responsibility for error, omissions or inadequacies of any sort on submitted data or shop drawings.
- 5. Copies of contract drawings will not be accepted as shop drawings and will be returned without review.

B. Prior to commencing work on shop drawings, the contractor shall facilitate a meeting between the contractor and Architect and his consultant to “walk through” the AV systems.

C. Conduit, Backboxes and Electrical Systems Verification Letter:

1. Within 30 days of contract award, the AV contractor shall review all relevant information pertaining to the AV systems low-voltage conduit, backboxes, and line voltage electrical work to be performed by Division 26. A formal memo, outlining acceptance (or desired changes) of the contract drawing shall be provided. Failure to provide this memo indicates acceptance of, and liability for, the conduit, backboxes and electrical systems as indicated in the Drawings.
2. If the contractor chooses to exercise the option to place conduit in-slab and on-grade or under-slab and in-grade, the contractor shall submit a revised AV conduit riser with new conduit size calculations using cables from the "wet-rated" AV cable schedule. See section 260535 for additional information.

D. Shop Drawings:

1. Submit full-size (minimum 30" x 42") scaled shop drawings that show the following:
 - a. Installation requirements and mounting conditions.
 - b. Provide stamped structural drawings by a structural engineer licensed in the state in which the project takes place showing complete mounting details for all AV devices over 20 pounds.
 - c. Full system riser diagram(s) illustrating interconnection of system components, wiring requirements, back box sizes and any special installation considerations.
 - d. Block diagrams, showing equipment interconnection.
 - e. Equipment rack and patchpanel drawings.
 - f. Full-scale drawings of custom plates.
 - g. Run sheets or field wiring drawings.
 - h. Equipment modification drawings, including statement of purpose for modification and agreement to provide full manufacturer warranty, if modifications cause a voided warranty.
 - i. Final schematic drawings of any custom circuitry.

E. AV Control System Touchpanels:

1. Provide a hosted web link for approval of working touchpanel files.
 - a. This generally requires the contractor to setup and host an active control system processor, with a secure web link to allow remote parties to view & control.
2. The AV contractor is responsible for design of touchpanel layouts, but shall be subject to consultant and Architect approval.
 - a. If the organization has an existing template, the AV contractor shall use that template and modify as needed to suit the project.

F. Product Data:

1. Submit a detailed equipment list, including manufacturer, model number, description and quantity for each item.
2. Do not submit equipment cut sheets, except for custom or non-standard devices.

- G. Color Data:
1. Submit spreadsheet with color schedule for all equipment and devices, including custom plates, speakers, racks, furniture, etc. Room name and number shall be listed.
 2. Show standard color options to allow design team to select.
 3. Where no option for color is available, indicate as much.
- H. DSP Programming:
- a. Internal DSP programming (submit as software file)
- I. Samples:
1. Submit samples for review if requested. Samples may include, but are not limited to:
 - a. Connector, panel and cable assemblies
 - b. Panel finish samples
 - c. Custom switch, button or similar assemblies
- J. Record Documents: Submit record documents in accordance with Section 01.
1. At time of final acceptance, submit regulatory listings and certifications as required by prevailing building codes.
 2. Submit electronic "as-builts" including:
 - a. Shop drawings, product data, operations and instructions manuals for all products provided.
 - b. Equipment list, with manufacturer, model number, and serial number for all installed devices.
 - c. Electronic backup of control system programming.
 - d. Electronic backup of DSP systems programming.
 - e. Care and maintenance instructions, service line and online contacts.
 - f. Warranty documents.
 - g. Key list, showing the following for all keys in the system: device name and model number, system controlled, key model number or other replacement identifier, tech support number for equipment manufacture, and thumbnail picture of device.

1.8 WARRANTY:

- A. Warranty shall provide coverage of material and product defects and assembly workmanship or installation for a period of two years following the date of acceptance by the Architect.
- B. Items under warranty shall be serviced to the satisfaction of the Authority with 14 days of notification to the Contractor.
- C. The Contractor shall bear all costs that arise as a result of the warranty claim, including, but not limited to, the use of temporary replacement components, additional Authority staffing or overtime, shipping, cancelled uses or performances.

- D. Activate all manufacturers' warranties in the name of the Authority, within one week of the date of acceptance.
- E. Provide return visits following system acceptance to fine tune or repair any items requested by the Authority:
 - 1. 1 month following acceptance
 - 2. 1 year following acceptance
 - 3. 2 years following acceptance

1.9 QUALITY ASSURANCE:

- A. Equipment in this Section shall be provided by specialty subcontractors and manufacturers meeting the qualifications listed herein.
- B. Specialty subcontractor shall have been continuously engaged in the sales and integration of audio, video and communications equipment similar to that specified herein for a minimum of 10 years.
- C. Specialty subcontractors shall have at time of bid and continuously maintain throughout the project and warranty period a C-7 and/or C-10 California Specialty Contractor's license appropriate for the work in this Section.
- D. Specialty subcontractors shall employ field service technicians within a four hour driving distance from the Project site.
- E. Contractor must have individuals with the following current credentials on staff:
 - 1. Avixa CTS-I and/or CTS-D certification
 - 2. Crestron Master Programmer on staff, or as a frequently-used subcontractor.
 - 3. Crestron NVX certification
 - 4. QSC Q-Sys Level 2 Certification
 - 5. Dante Level 3 Certification
 - 6. Ross Video Authorized Dealer
 - 7. Cisco Professional Certification
- F. All equipment shall be UL or ETL listed and bear the appropriate labels.

1.10 DELIVERY, STORAGE AND HANDLING:

- A. Packing shall prevent damage to the equipment during transit. Costs to repair or replace all equipment damaged during the course of the contract services shall be borne by the Contractor.
- B. Do not deliver materials in this Section until building is ready for installation. Contractor is responsible to properly sequence the work and to protect from damage during delivery, handling, storage and installation.
- C. Contractor is responsible to coordinate and provide secure and protected storage as required for the execution of the Contract.

1. Devices shall not be delivered to the project site until the project is suitably clean and all adjacent finish work that may be painted or produce dust has been completed. The contract shall provide and maintain complete protection of all devices until the Project has been made available for occupancy by the Authority. The contractor shall thoroughly clean and remove any dirt or dust that infiltrates system components and be responsible for timely replacement of any damaged components.
2. Device labels and connectors shall be delivered with temporary dust and paint protection installed.

1.11 PROJECT CONDITIONS:

- A. Defects in the field which may impact the work in this Section shall be reported to the Architect and corrected in accordance with the requirements of the applicable Section of Work prior to commencement of the Work in this Section.

1.12 MAINTENANCE:

- A. Provide maintenance stock of user-serviceable components within the system. Maintenance stock shall be packaged in labeled long term storage packaging and turned over to the Authority at time of system commissioning.
- B. Maintenance stock shall include:
 1. Four fuses of each type in the system.
 2. Five connectors of each type in the system.
 3. Six spare keys of each type in the system.
 4. Components recommended by the manufacturer.
 5. Any non-standard tools required for Authority service.

PART 2 - PRODUCTS

2.1 SPECIALTY SUBCONTRACTORS

- A. All AV system contractors shall submit qualifications for approval at time of bid. In order to qualify, the contractor shall submit the following information for review:
 1. Proof that all requirements of Quality Assurance, Section 1.9 are met.
 2. List of personnel who will be working on this Project, including skills, experience, and accreditations.
 3. List of union affiliations, contractor licenses, and other applicable trade certifications.
 4. List of projects completed within the past 5 years, with references. Provide phone and/or e-mail addresses for reference contacts.
 5. Proof that at least 5 jobs in the past 5 years have a minimum contract value equal to or greater than the project listed herein, and are of similar type.

2.2 MANUFACTURERS:

- A. AV equipment in this Section shall be provided by specialty manufacturers providing products meeting the specifications herein.
- B. Provide all equipment as listed in 274117-A, equipment list.

2.3 SYSTEMS:

- A. Audio Systems General Requirements:
 - 1. Grounding: All grounding in racks is the responsibility of the AV contractor. All devices shall be appropriately grounded to the isolated grounding system busbar.
 - 2. Un-Balanced Devices: Provide a balancing transformer for any unbalanced device, at both input and output.
 - 3. Loudspeaker Rigging: All overhead loudspeaker rigging shall be reviewed and stamped by a licensed structural engineer working in the state in which the project takes place. The contractor is responsible to secure the structural stamp, including all expenses associated therein.
- B. Video Systems General Requirements:
 - 1. Reference SMPTE standard for specified SDI video type.

2.4 MATERIALS:

- A. All components supplied under this Section shall be new. Used or factory reconditioned components will not be acceptable.
- B. Floor-Standing Pull-Out 19" Equipment Rack
 - 1. Provide Middle Atlantic MRK-AXS Series, in sizes as indicated in the drawings.
 - 2. 500 lb. weight capacity, with seismic rating.
 - 3. All structural elements shall be finished in black powder coat.
 - 4. Rack shall be UL Listed.
 - 5. Provide the following options:
 - a. Removable keylocked side panels, model #SPN-xxx. One pair per rack bank.
 - b. No top panel to allow inner rack fans to have a clear air path.
 - c. Vertical Lacer strip, heavily perforated, 77" long, model # LACE-xx-OP. Two per rack.
 - d. Horizontal Lacer Bars, model #LBP series. Ten per rack, or as needed.
 - e. Brush Grommit panel, model #BRxx series. As needed.
 - f. Rear rail kit, 11-gauge, 10-32 threaded, model # WRK-RRxxx. One per rack.
 - g. Copper Bus Bar, model #BB-xx. One per rack.
 - h. Service Track, model #TRACK-50. One per rack.
 - i. Service Stand, model #TRACK-L. One per rack.
 - j. Wire Tray, model #AXS-WT50. One per rack.
 - k. Utility Drawer, model D4. One per rack group.
 - l. Blank & Vent panels, as needed to fill rack.

- m. Full height utility light, white w/ dimmer, model FWD-LT-UTL-xxx-D. One set per rack. Provide maximum length allowed by rack size.
 - n. Custom rack mounts for equipment without rack ears, model #RSH-series.
6. Follow attachment methods as described in the drawings, which meet structural criteria provided by the project structural engineer.
7. Provide the following for thermal management:
- a. Dual Fan Kit, model #AXS-FAN-K with guard. One per rack.
 - b. Vent Blockers, model VBK-W27-W32. As required.
 - c. Thermostatic Fan Control for MPR raceway, model #FC-4A. One per rack group.
 - d. Vent panels at bottom of rack, model VT-series. As required.
8. Provide the following for power management:
- a. Provide as indicated in the equipment list.
 - b. Non-switching front-mounted convenience outlets. Provide one unit per rack group. Model #PD-2015R-NS or equal.
- C. Connectors:
1. Microphone and Line Level Audio
- a. XLR-M, 3-pin:
 - 1) For panel-mount, Provide Neutrik NC3MD-L-1, 3-pole male XLR connector in black.
 - 2) For cable-end, provide Neutrik NC3MXX, 3-pole male connector.
 - b. XLR-F, 3-pin, Standard
 - 1) For panel-mount, Provide Neutrik NC3FD-L-1, 3-pole female XLR connector in black.
 - 2) For cable-end, provide Neutrik NC3FXX, 3-pole female connector.
 - c. XLR-F, 3-pin, Automixing (BLUE)
 - 1) For panel-mount, Provide Whirlwind WC3F, 3-pole female XLR connector in blue color shell.
 - 2) No colored trim rings allowed, such as Neutrik.
 - d. 1/4" Tip/Ring/Sleeve
 - 1) For panel-mount, Provide Neutrik NJ3FP6C, locking tip/ring/sleeve connector.
 - 2) For cable-end, provide Neutrik NP3X, tip/ring/sleeve connector.
 - e. Phono
 - 1) For panel-mount, Provide Neutrik NF-2D series, with appropriate color isolation washer.

- 2) For cable-end, provide Neutrik NF2C-B-2 “Profi” connector.
2. Video:
 - a. Production Video:
 - 1) For panel-mount, Provide recessed bulkhead jack, feed through, isolated connector. Use appropriate connector for cable specified. Neutrik preferred if available.
 - 2) For cable-end, provide appropriate BNC connector for cable specified. Neutrik preferred if available.
 - b. “F” Connector:
 - 1) For panel-mount, provide Cencom GF81 inline barrel connector with 1 GHz minimum performance.
 - 2) For cable-end, provide Cencom Superlock compression connector with 1 GHz minimum performance.
 3. Data:
 - a. RJ-45
 - 1) For panel-mount, provide Neutrik Ethercon NE8-series punchdown connector in black to match cable type.
 - 2) For cable end, provide Neutrik Ethercon NE8-series connector in black to match cable type.
 - b. Fiber
 - 1) For panel-mount, provide Neutrik Opticalcon NO2-4FD feed-thru panel mount connectors.
 - 2) For cable end, provide Neutrik Opticalcon cables in quantities shown in 274117-A equipment list.
- D. Patchbays:
1. Microphone and Line Level Audio:
 - a. Provide Bittree 481 Classic series with ID (punchdown) style termination with the following options:
 - 1) Longframe ¼”-style connectors
 - 2) 2x26 jacks with 12” deep chassis
 - 3) 2 designation strips in over/under configuration
 - 4) Mono spacing, 2 RU
 - 5) Isolated Grounding
 - 6) Normals per Drawings
 - 7) Black in color
 - 8) Paper designation strips. Provide .doc file to Authority for future use.
 - 9) Provide Middle Atlantic “CLAW” patchcord holder, one per rack.

- b. Patchbay layout shall be in standard “output at top, inputs at bottom” scheme with clear method for showing normals. Contractor shall be responsible for exact patchbay layout.
 - c. Labeling shall be as follows:
 - 1) All labeling shall exactly match circuit in field.
 - 2) Labeling shall be sequential per circuit type, beginning at 1.
 - d. Or equal by AVP, Inc.
2. 12G-SDI Production Video:
- a. Provide Bittree Video MINI-WECO 12G+ series patchbay.
 - b. Provide the following configuration:
 - 1) WECO-style connectors
 - 2) 2x32 jacks with 12” deep chassis
 - 3) 2 designation strips in over/under configuration
 - 4) 2 RU
 - 5) Normals per Drawings. Provide looping plugs in quantities needed.
 - 6) Black in color
 - 7) Paper designation strips. Provide .doc file to Authority for future use.
 - 8) Provide Middle Atlantic “CLAW” patchcord holder, one per rack.
 - c. Or equal by AVP, Inc.
3. Data - Copper:
- a. Provide Bittree DSK Series Flush-Mount Modular Keystone Panel.
 - b. Provide with the following configuration:
 - 1) CAT 6A Shielded
 - 2) RJ45 jack with 110 IDC punchdown interface with shielding
 - 3) 1x24 jacks with 6” deep removeable rear lacing bar
 - 4) 1 designation strip in over configuration
 - 5) 1 RU
 - 6) Black in color
 - 7) Paper designation strips. Provide .doc file to Authority for future use.
 - 8) Provide Middle Atlantic “CLAW” patchcord holder, one per rack.
4. Data - Fiber
- a. Provide Bittree DSK Series Flush-Mount Modular Keystone Panel.
 - b. Provide with the following configuration:
 - 1) Duplex LC to LC Fiber
 - 2) 1x24 jacks with 6” deep removeable rear lacing bar
 - 3) 1 designation strip in over configuration
 - 4) 1 RU
 - 5) Black in color
 - 6) Paper designation strips. Provide .doc file to Authority for future use.

5. Provide Middle Atlantic "CLAW" patchcord holder, one per rack. Mount to wall adjacent equipment rack.

2.5 PANELS:

- A. General: The control receptacle panels shall consist of the appropriate connectors required for the system.
- B. Physical:
 1. Faceplates shall be 0.080" aluminum, edges eased, finished in fine texture, scratchresistant powder coat, with fasteners countersunk.
 - a. Panels specified as flush mounted shall overlap back box by 1/2". Surface mounted panels shall match back box size with no gaps or overlap.
 - b. Coordinate back box type, size and mounting with Division 26 - Electrical.
 2. Color shall match the finished wall color of the wall onto which it will be mounted, unless otherwise noted. Submit color table for review.
 3. Panels noted as custom color shall be factory powder coated a color selected by the Architect. Legends shall be laser etched.
 4. Laser etched labels 1/4" high characters minimum, unless otherwise noted.
 - a. Labeling shall be as indicated on the Drawings.
 - b. Use Arial font.
 5. Wall mounted panels shall mount into an industry standard back box, depending on size and quantity of connectors.
 6. Rack mounted panels shall mount within industry standard equipment racks.
 7. Panels mounted in floor boxes shall include a translucent flexible vinyl dirt guard as indicated on Drawings.
 8. Provide complete hardware for mounting on gridiron hangers where indicated on the Drawings.
 9. Provide black aluminum cable tie-off bars on all panels 8" wide and larger, as indicated on the Drawings.
 - a. Keystone Electronics Corporation "Aluminum Oval Instrumentation Handles", part number 546, 5" wide x 2" deep handle. www.keyelco.com; 800-221-5510
- C. Floor Pockets:
 1. Provide flush, floor mounted pockets with hinged steel cover and cable slot. Finish flat black, unless otherwise noted.
 2. Provide interior, flexible translucent PVC dirt guard to cover receptacles. Labels shall remain visible.
 3. Provide floor pocket backboxes and pour pans (if conditions warrant) to Division 26 - Electrical for installation.

PART 3 - EXECUTION

3.1 INSTALLATION- GENERAL:

- A. Coordinate with Division 26 - Electrical for the proper installation of the conduit, backboxes, and electrical service as specified herein.
- B. Coordinate scheduling and access with the Contractor and provide personnel lifts or ladders as required for access to the AV equipment.
- C. Remove all packing materials from the Project Site. Insert operations and maintenance information into the Project record documents as specified above in Submittals.
- D. Record Block Diagram: Post a laminated 11x17 as-built block diagram of the entire system (split into multiple sheets as necessary), and physically attached to the equipment rack in a logical location for Authority reference.

3.2 CABLE INSTALLATION:

- A. Mark cables, regardless of length, with permanent, non-handwritten number or letter cable markers within 6-inches of both ends. There shall be no unmarked cables in the system. Marking codes used on cables shall correspond to codes used on Drawings and schedules.
- B. As indicated on the Drawings, group cables according to signal type. Up to 6 separate conduit systems may be in place, divided as follows:
 - 1. A: Microphone Level Audio
 - 2. B: Line Level Audio
 - 3. C: Video and Communication Level
 - 4. D: Loudspeaker Level
 - 5. E: Empty/Future expansion
 - 6. F: Fiber Optic Level
- C. As much as possible, maintain separation of signal types when outside of conduit.
- D. No cable shall be installed with a bend radius less than recommended by the manufacturer.
- E. Cables types shall be as indicated on the Drawings. In plenum spaces, provide the plenum version of the specified cable type.
- F. No cable splicing is allowed, except for systems that are daisy-chained.

3.3 PROTECTION OF PROPERTY:

- A. Contractor is responsible to provide protection for all equipment, tools and materials delivered to the Project Site prior to final acceptance by Authority. Any loss or damage is the responsibility of the contractor, until final acceptance by Authority.

3.4 SEQUENCING:

- A. The contractor shall not install any electronic equipment until the room where the equipment shall be located has been finally painted or otherwise finished, and cleaned by the Contractor or Authority's Representative. Any damage to equipment resulting from failure to follow this requirement will result in the contractor replacing the damaged equipment at their cost.

3.5 COMMISSIONING AND DEMONSTRATION:

- A. Coordinate with Division 26 - Electrical.
- B. Appropriately trained personnel shall review, test, program and otherwise complete the system, following completion of installation.
- C. Upon completion of the installation, the Contractor shall notify the Architect that the system is available for formal checkout. Notification shall be provided in writing. Checkouts shall be scheduled in accordance with the Architect's schedule.
- D. Audio System Tuning:
 - 1. Following complete system installation, each device shall be set for correct gain-staging.
 - 2. System shall be tuned prior to final checkout by contractor, using a computer-based audio analysis program, such as SMAART, TEF, or SIMM. A factory-certified individual shall carry out the tuning.
- E. Cable Television System Tuning:
 - 1. Following complete installation, each device in the CATV system shall be tuned to exact an output of +5 dBmV, +/- 3 dBmV at the television output.
 - 2. Audio input at the modulator shall be set in accordance with the gain staging requirements covered in the audio sections.
 - 3. Video input at the modulator shall be set per manufacturer's guidelines.
- F. Provide to the Architect and or his Consultant the following upon arrival:
 - 1. Measurements of impedance of each loudspeaker prior to connecting it to an amplifier.
 - 2. Measurements confirming the polarity of each loudspeaker, from output of console through entire system.
 - 3. Measurements showing all Ethernet wiring complies with Category 6A requirements for full bandwidth operation.
 - 4. Verification that every line has been sweep tested and conforms to standard requirements per signal level.
 - 5. Measurements showing CATV output voltage at each TV outlet.
 - 6. Demonstration of input and output of signal throughout the entire audio system.
- G. Make available for review by the Architect and or his Consultant:
 - 1. All components for physical inspection and inventory.
 - 2. A computer to access any DSP units.
 - 3. All installed devices in full operation, with no temporary equipment in place.
 - 4. All portable devices, fully complete, and available to test at all plug-in locations.

- H. The Contractor shall be liable for any return visits by the Architect and/or his consultant as a result of incomplete or incorrect installation, or erroneous representation that the Systems are complete and ready for the Architect to carry out its work.
- I. The Contractor shall arrange for access as necessary for inspection of equipment by the Architect and or his consultant
- J. Upon completion of the commissioning, Contractor shall demonstrate operation and maintenance of the system to the Authority. Coordinate with the Authority's schedules two weeks in advance minimum.

3.6 TRAINING:

- A. Provide training as follows:
 - 1. One day with user group one week prior to initial handover.
 - 2. One day with user group and maintenance staff one month after initial training.
 - 3. One day with user group and maintenance staff one year after initial training, but prior to warranty expiration.
- B. Training sessions noted above are in addition to any manufacturer-provided training requested in the specification
- C. Provide technician on site during the first council meeting to assist with operations.
- D. Training shall include, but not be limited to:
 - 1. Safety precautions.
 - 2. Identification of all elements provided under this section.
 - 3. Maintenance, diagnostics and trouble shooting.
 - 4. Operation of system, including necessary software training.
 - 5. Operations and maintenance manual orientation.

3.7 PROJECT CLOSEOUT:

- A. See submittal section above for required closeout documents.

3.8 APPENDIX:

- A. 27 41 17-A Equipment List

**Oakland Housing Authority - Board Room
274117A - AV Systems Equipment List**

- Notes: 1. Conduit, backboxes and electrical power required for A/V systems are existing.
 2. This list contains key components, but does not list every piece needed for a complete system.
 Contractor is responsible to provide a complete and working system, regardless of the completeness of this list.
 3. A/R = As Required.
 4. OFCI = Owner Furnish, Contractor Install

REF	DESCRIPTION	MFR	MODEL	QTY	NOTES	COST
COUNCIL CHAMBERS						
Audio System - Reinforcement						
<i>DSP</i>						
1MA	Audio DSP	QSC	Core 110f	1		
2MA	<i>Wireless Microphone</i>					
3MA	Wireless Mic Handheld TX & RX	Shure	QLXD24/SM58	2	w/ rechargeable battery & rackmount	
4MA	Wireless Mic Bodypack TX	Shure	QLXD1	2	w/ rechargeable battery	
5MA	Wireless Mic Lavalier Element	Countryman	B3	2	color TBD	
6MA	2-port battery charger, Drop In	Shure	SBC200	2		
7MA	Antenna Distribution	Shure	UA 844	1		
8MA	Antennas, Powered, Wall Mount	Shure	UA 864 US	2		
9MA	<i>Loudspeaker Systems - Board Room</i>					
10MA	Ceiling Mount Loudspeaker	<reuse existing>	<reuse existing>	0	<Qty: 15 - reuse existing>	
11MA	4-ch Audio Amplifier, 70v/500w, QLAN	QSC	CX-Q 2K4	1		
12MA	<i>Loudspeaker Systems - Meeting Room</i>					
13MA	70V Volume Control "SA"	<reuse existing>	<reuse existing>	0	<Qty: 1 - reuse existing>	
14MA	Ceiling Mount Loudspeaker	<reuse existing>	<reuse existing>	0	<Qty: 2 - reuse existing>	
15MA	<i>Loudspeaker Systems - Control Room</i>					
16MA	70V Volume Control "SA"	<reuse existing>	<reuse existing>	0	<Qty: 1 - reuse existing>	
17MA	Ceiling Mount Loudspeaker	<reuse existing>	<reuse existing>	0	<Qty: 1 - reuse existing>	
18MA	<i>Discussion System Hardware</i>	<i>Ref Quote #MV-18661</i>				
19MA	Central Control Unit	Taiden	HCS-4100MC/52	1		
20MA	Loop Switcher	Taiden	HCS-8300MCLS	1		
21MA	Loop Switcher Rack Mount	Taiden	HCS-8300MCLS-BKT	1		
22MA	Distributor 1x3	Taiden	HCS-4352T/50	6		
23MA	Discussion Unit w/ Voting, Chairman	Taiden	HCS-4890CVS/52	2	one spare	
24MA	Discussion Unit w/ Voting, Delegate	Taiden	HCS-4890DVS/52	14	one spare	
25MA	<i>Discussion System Software</i>					
26MA	Basic System Setup & Management	Taiden	HCS-4210/52	1		
27MA	Microphone Management	Taiden	HCS-4213/50	1		
28MA	Voting Management Software	Taiden	HCS-4214/50	1		
29MA	Audio Recording Software	Taiden	HCS-4219/50	1		
30MA	Congress Matrix Software	Taiden	HCS-4239/50	1		
31MA	On-Site Setup & Training, 1-day	Taiden	MV-COMM-NA	1	include travel/accommodation	
32MA	Service Level Agreement, Gold, 1-year	Taiden	MV-SLA-GOLD	2	years	

REF	DESCRIPTION	MFR	MODEL	QTY	NOTES	COST
33MA	Discussion System - Rackmount PC	Dell	Precision 7920 Rack	1	equip per mfr recommendation	
34MA	Discussion System - Rackmount PC, Video Card	NVIDIA	Dual NVIDIA Quadro P2k, 4DP Out	1		
35MA	<i>Public Speaker Lectern</i>					
36MA	Lectern Microphone, LED indicator, shock mount	Shure	MX418S/C	1		
37MA	<i>Utility</i>					
38MA	Audio over IP Switch, Gigabit, Q-SYS/Dante	Cisco	Catalyst 9300 Series	1		
39MA	Data Patchbay / RJ-45 / CAT6A STP	Bittree	DSK Series	A/R	see specs for further info	
40MA	Network Patch Cable, CAT6A STP, Blue, 3'	Comprehensive	CAT6A-3BLU	10		
41MA	Audio Patchbay, 1/4" Longframe	Bittree	489 Programmable	A/R	See specifications	
42MA	Audio Patch Cable, Red, 3'	AVP	LPC-3-RED	10		
43MA	Audio Combining Networks	Radio Design Labs	STD-600	2		
44MA	Audio Isolation Transformers	Radio Design Labs	TX-AT1	2		
45MA	Bulkhead XLR/BNC Patchbay	AVP	Maxxum Series	A/R		
46MA						
47MA						
48MA	Miscellaneous Hardware					
49MA	Wire & Cable					
50MA	Labor					
	Assistive Listening					
1MA	IR Base Station	Listen Technologies	LA-82	0	<Qty: 2 - reuse existing>	
2MA	IR Base Station Rackmount	Listen Technologies	LA-326	0	<Qty: 1 - reuse existing>	
3MA	IR Emitter	Listen Technologies		0	<Qty: 2 - reuse existing>	
4MA						
5MA						
6MA	Miscellaneous Hardware					
7MA	Wire & Cable					
8MA	Labor					
	Video Systems- Presentation					
	<i>Projection</i>					
1VI	Video Projector, 7k Lumen, 1920x1200, LCD, Lamp-based	Maxell	MC-WU8701W	1	operate in 16:9 mode	
2VI	Video Projector Lens	Maxell	A/R	1	field measure to fit screen/throw	
3VI	Video Projector Lamp, Spare units	Maxell	A/R	2		
4VI	HDMI Decode - Brick	Crestron	DM-NVX-D30	1		
5VI	Motorized Projection Lift (20"x20", 35# max projector)	<reuse existing>	<reuse existing>	0	<Qty: 1 - reuse existing>	
6VI	Motorized Projection Screen, 1.77:1 aspect	<reuse existing>	<reuse existing>	0	<Qty: 1 - reuse existing>	
7VI	<i>Flat Panel</i>					
8VI	86" LCD Monitor, 4k/UHD, LAN/232 control	Samsung	QM Series	2		
9VI	HDMI Decode - Brick	Crestron	DM-NVX-D30	2		
10VI	Ceiling Mount Assembly	Chief	XCM1U + CPA column/plate	2		
11VI	<i>Switching & Transport</i>					
12VI	Streaming Card Frame/PSU, 8 Slot	Crestron	DMF-CI-8	1	Booth	
12VI	HDMI Encode/Decode + Scaler/KVM - Blade	Crestron	DM-NVX-360C	7		
13VI	Dual HDMI Encode/Decode + Scaler/Dante/KVM - Blade	Crestron	DM-NVX-352C	1		
14VI	Digital Media Switching Appliance	Crestron	DM-XIO-DIR-80	1		

REF	DESCRIPTION	MFR	MODEL	QTY	NOTES	COST
15VI	Video over IP switch	Cisco	Catalyst 9300 Series	1		
16VI	<i>Control Desk - Encode</i>					
17VI	HDMI De/Encode- Brick w/ Dual HDMI in	Crestron	DM-NVX-352	1		
18VI	Dual HDMI input panel, 1RU	Contractor	Custom	1		
19VI	<i>Dias Monitors</i>					
20VI	22" Video Monitor, 1920x1080, VESA Mount	Samsung	A/R	11		
21VI	VESA Articulating Arm Mount for Video Monitor	Chief Mfg	K1D120_XRH	11		
22VI	HDMI Decode - Brick	Crestron	DM-NVX-D30	1		
23VI	HDMI Distribution Amplifier 1x8	Crestron	HD-DA8-4KZ-E	2		
24VI	HDMI Cable, Highly Flexible	Extron	HDMI Ultra/xx	12	length as needed	
25VI	<i>Clerk/Staff</i>					
26VI	22" Widescreen Video Monitor, 1920x1080, VESA Mount	Samsung	A/R	1	Clerk	
27VI	VESA Articulating Arm Mount for Video Monitor	Chief Mfg	K1D120_XRH	1		
28VI	22" Widescreen Video Monitor, 1920x1080, Table Mount	Samsung	A/R	1	Staff	
29VI	Keyboard / Mouse	A/R	A/R	2	Clerk/Staff	
30VI	Dual HDMI Encode/Decode + Scaler/KVM - Brick	Crestron	DM-NVX-350	4		
31VI	Fliptop Unit	Crestron	FT2-700-ELEC-xx	2		
32VI	Fliptop- Charging Module - USB A/C Charger	Crestron	FT2A-CHGR-USB/A/C	2		
34VI	Fliptop- Power Module - 120v Power	Crestron	FT2A-PWR-US-2	2		
33VI	Fliptop- Cable Pass Thru - 4k HDMI	Crestron	FT2A-CBL-PT-4K-HD	6	3/unit	
35VI	Fliptop- Cable Pass Thru - CAT6	Crestron	FT2A-CBL-PT-CAT6	2		
34VI	Fliptop- keystone Module, 10-pack	Crestron	FT2A-PLT-KEY-10	1	2/unit. Load keystones w/ USB	
36VI	Fliptop- Blank Module, 10-pack	Crestron	FT2A-PLT-BLANK-10	1		
37VI	<i>Meeting Room</i>					
38VI	65" LCD Monitor, 4k/UHD, LAN/232 control	Samsung	QM Series	1	variable audio output	
39VI	HDMI Decode - Brick	Crestron	DM-NVX-D30	1	Chambers Feed	
40VI	Soundbar/Camera/Microphone Unit	Crestron	UC-SB1-CAM	1		
41VI	Small Form Factor PC (Zoom)	Dell	OptiPlex 5080 Micro	1	or similar	
42VI	Flat Panel Mounting Bracket, Tilt, Wall	Chief Mfg	A/R			
43VI	Touchpanel, iPad (Zoom)	Apple	iPad 10.2-inch	1		
44VI	Touchpanel Table Locking Sleeve	Heckler Designs	H600X-BG	1		
45VI	Lock/Swivel for Sleeve	Heckler Designs	PivotTack	1	cable power into table base	
46VI	Crestron app for iPad	Crestron	A/R	1		
47VI	Table Pocket (HDMI, 120VAC, CAT6A, USB power)	FSR, Inc	T3-DV2S-BLK	1	install in (e) table	
48VI	Floor Pocket	<reuse existing>	<reuse existing>	0	<Qty: 1 - reuse existing>	
49VI	Wall Box	Chief Mfg	PAC-526	1		
50VI	<i>Presentation</i>					
51VI	Presentation CPU	Dell	Precision 3930 Rack	1		
52VI	<i>Informacast - Mass Notification</i>					
53VI	Informacast Appliance	OFCI	OFCI	0	<Qty: 1 - OFCI>	
54VI	Rack Shelf	Middle Atlantic	A/R	1		
55VI						
56VI						
57VI	Miscellaneous Hardware					
58VI	Wire & Cable					
59VI	Labor					

REF	DESCRIPTION	MFR	MODEL	QTY	NOTES	COST
	Broadcast Systems					
	<i>Video Switcher- Frame</i>					
1VI	Video Switcher, 1ME	Ross Video	CBF-113	1		
2VI	<i>Video Switcher- Control Surface</i>					
3VI	Control Surface, 1ME	Ross Video	CB9-PANEL	1		
4VI	<i>Video Switcher- Warranty & Setup</i>					
5VI	Production Video Switcher- On-Site Mfr Training	Ross Video	CARBONITE-OTR-1DAY	1	days	
6VI	Production Video Switcher- On-Site Mfr Setup	Ross Video	CARBONITE-COM-1DAY	1	days	
7VI	Travel	Ross Video	TRAVEL-PRE-001	1		
8VI	<i>Routing</i>					
9VI	34x34 SDI Router	Ross Video	NK-3G34	1	Provide PSU	
10VI	IP Control Interface	Ross Video	NK-NET	1		
11VI	<i>Monitoring & Control</i>					
12VI	Dashboard- GUI layout services	Ross Video	DB-LCS-001	1		
13VI	DashBoard- Multimedia ViewControl	Ross Video	DB-VCMM-000	1	includes 23" touchscreen & cables	
14VI	DashBoard- Turnkey Client	Ross Video	DB-TURNKEY-HW	1	includes all-in-one 23" touch PC	
15VI	Rackmount LCD Monitor, 15.6"	Black Magic	SmartView 4k	1		
16VI	12GSDI to HDMI	Decimator	12G-CROSS	2		
17VI	USB Joystick for Lighting	Apem	VM Desktop	1		
18VI	Articulating Mount	Chief Mfg	Kontour K1D	2		
19VI	<i>Control- Warranty & Setup</i>					
20VI	Dashboard- Commissioning, Off-site	Ross Video	DB-LCS-COM-OFFSITE-1DAY	2	day	
21VI	Dashboard- Online Training	Ross Video	DB-LCS-ONL-1DAY	2	day	
22VI	<i>Graphics</i>					
23VI	CG system - Hardware Server, 1RU, Mouse	Ross Video	XPR1-0101-M8	1		
24VI	CG system - Software Licence	Ross Video	XPR-DLQ	1		
25VI	CG system - Custom Keyboard	Ross Video	XPN-KBD	1		
26VI	CG system - 23" monitor, 1920x1200, VESA	A/R	A/R	1	see mount below	
27VI	CG system - mouse	A/R	A/R	1		
28VI	HDMI over Fiber Cable	Extron	HD Pro P/xx	1	Verify length in field	
29VI	USB Extender Tx over DM	Crestron	USB-EXT-DM-LOCAL	1		
30VI	USB Extender Rx over CATx	Crestron	USB-EXT-DM-REMOTE	1		
31VI	<i>Camera- Chambers</i>					
32VI	PTZ Camera, NDI output, 12G, White	Ross Video	PIVOTCam-SE-W	4		
33VI	PTZ Camera Wall Mount, White	Ross Video	PIVOTCAM-SE-WM-W	2		
34VI	PTZ Camera Ceiling Mount, White	Ross Video	PIVOTCAM-SE-CM-W	2		
35VI	<i>Signal Processing</i>					
36VI	HD-SDI DA, 1x6	Aja	3GDA	2	Provide Rack mount	
37VI	Sync Generator & Distribution	Aja	GEN10	1		
38VI	12GSDI to HDMI	Decimator	12G-CROSS	1	B'cast to Presentation	
39VI	<i>Audio</i>					
40VI	Audio Mixer, Dante, 8-ch	Shure	SCM820-DAN-DB25	1		
41VI	SDI/Analog Audio Embed/De-embed	Aja	3AMA	1		
41VI	Audio Monitor, Powered	JBL	C2PS	1	pair	
42VI	Wall Mount for Powered Monitor	JBL	MTC-2P Mounting kit	1		

REF	DESCRIPTION	MFR	MODEL	QTY	NOTES	COST
Utility, Plates & Panels						
1MA	Equipment Racks & Accessories, Booth - Pull-Out Type	Middle Atlantic	MRK/AXS-Z4 Series	1	see specs for additional requirements	
2MA	Power Raceway, Vertical, Dual Circuit	Middle Atlantic	PDT-2x1020T	2		
3MA	Power Sequencer Control, 6-step	Middle Atlantic	PDS-620R	0	<reuse existing>	
4MA	UPS Unit	Middle Atlantic	UPS-1000R	1		
5MA	Gang Panel	Contractor	Contractor	A/R		
6MA	Multi-I/O Panel	Contractor	Contractor	A/R		
7MA	Floor Box ,10" Poke Thru, Fire Rated	FSR, Inc	SF10-CVR-ALM	1	core drill required	
8MA	Dias 120V/USB Table Pocket, Black, 9' cord	FSR, Inc	TC-CHRG-BLK-9	11	coordinate installation w/ Dias	
9MA	Tabletop Rack	Middle Atlantic	DTRK Series Desktop Rack	1	mount to top of existing control furniture	
10MA						
11MA						
12MA	Wire & Cable					
13MA	Labor					
FFE/LOOSE EQUIPMENT						
Accessories						
1PE	HDMI to HDMI Extension Cables, 6'	Extron	HDMI Micro/6	4		
2PE	HDMI Adapter Keyring	Liberty	DL-AR2952	2	Note: Custom Config	
3PE	Audio Patch (longframe) to XLR-F, 3'	Bittree	LPCXM3602-110	4		
4PE	Audio Patch (longframe) to XLR-F, 3'	Bittree	LPCXF3602-110	4		
5PE	Video Patch (Mini WECO) to BNC Cable, 3'	Bittree	VPBM3600-75	4		
6PE						
7PE						
8PE	Miscellaneous Hardware					
9PE	Wire & Cable					
10PE	Labor					
		END OF SECTION				

Appendix B Oakland Housing Authority

BID FORM IFB No.21-005 (Page 1 of 2)

Boardroom Audio Visual Renovation

	A. Estimate d Hours	B. Davis- Bacon Hourly Rate	C. Total Labor Cost
Labor			
1. AV Systems, Installation			
2. AV Systems, Demolition			
3. Core Drill / Installation of poke thru			
4. Service Level Agreement, 1 year			
5. Other: _____			
<u>Subtotal</u> of Labor: (Add all cells from Column C for "Labor" subtotal)			
Material and Supplies: Provide line-item pricing for materials/equipment/manufacturer-provided services as indicated in the 274117 specification section, appendix B: equipment list.			
Administrative Costs (bonding, insurance, etc.):			
Permits:			
Overhead & Profit:			
Other Costs (Please list):			
GRAND TOTAL: (Add Subtotal for Labor, Subtotal for Materials and Supplies, Administrative Costs, Permits, Overhead & Profit, and Other Costs).			
Written amount of Grand Total: _____			

Oakland Housing Authority

BID FORM IFB No. 21-005

Boardroom Audio Visual Renovation

(Page 2 of 2)

The undersigned having examined the specifications, and being familiar with all of the conditions surrounding services of the proposed project; hereby proposes to furnish all labor, material, equipment, machinery, tools, supplies, permits and certificates, as listed below, to perform all work required, in strict accordance with OHA specifications and contract requirements. Any additional costs or alterations to this bid form will not be accepted. **Project will be awarded to lowest responsible, responsive bidder for the grand total bid amount.** Where there is a discrepancy between words and figures, **WORDS WILL GOVERN.**

Contractor Name: _____

Authorized Signature: _____

Title: _____ Date: _____

Address: _____

Telephone: _____ Fax: _____

Email Address: _____

Contractor License # _____

Appendix C
Specifications and Drawings

AV PANEL SCHEDULE							
DEVICE TYPE	LOCATION	DESCRIPTION	PANEL SIZE-FLUSH MOUNT	PANEL SIZE-SURFACE MOUNT	BOX TYPE-FLUSH MOUNT	BOX TYPE-SURFACE MOUNT	WIRING CONNECTION
AV-DAIS	COMMISSIONERS BOARD ROOM	MULTI-PANEL	2-GANG W/ GROMMET	N/A	(E) 2-GANG DOUBLE DEPTH BOX	N/A	HOME RUN TO AV RACK
AV-CLRK	COMMISSIONERS BOARD ROOM	MULTI-PANEL	(1) 2-GANG W/ GROMMET, (1) 5-GANG	N/A	(E) 2-GANG DOUBLE DEPTH BOX & 5-GANG DOUBLE DEPTH BOX	N/A	HOME RUN TO AV RACK
AV-FB	COMMISSIONERS BOARD ROOM	FLOOR POCKET	4-GANG, SIDE PANELS	N/A	FLOORBOX MFR: FSR MODEL: SF10-CVR-ALM	N/A	HOME RUN TO AV RACK
PTZ	COMMISSIONERS BOARD ROOM	PAN TILT ZOOM CAMERA	N/A DIRECT CONNECT	N/A	(E) 2-GANG DOUBLE DEPTH BOX	N/A	HOME RUN TO AV RACK
TLRPK	COMMISSIONERS MEETING ROOM	TABLE POCKET HDMI INPUT	PRE-MADE DEVICE	PRE-MADE DEVICE	(E)	N/A	HOME RUN TO AV RACK
WX	COMMISSIONERS BOARD ROOM	WIRELESS MIC ANTENNA	1-GANG W/ GROMMET	N/A	1-GANG MUD RING AT CEILING	N/A	HOME RUN TO AV RACK
IR	COMMISSIONERS BOARD ROOM	IR TRANSMITTER	1-GANG	N/A	1-GANG MUD RING CUT INTO WALL	N/A	HOME RUN TO AV RACK
SA	SEE DRAWINGS	70V VOLUME CONTROL	(E) 1-GANG	N/A	(E) 2-GANG DOUBLE-DEPTH BOX W/ 1-GANG REDUCER	N/A	HOME RUN TO AV RACK
FDP-P	COMMISSIONERS MEETING ROOM	FLAT PANEL DISPLAY WITH PULL-OUT MOUNT	N/A DIRECT CONNECT	N/A	CHIEF MFG MODEL: PAC526-FWC	N/A	HOME RUN TO AV RACK
FDP-C	COMMISSIONERS BOARD ROOM	FLAT PANEL DISPLAY WITH CEILING MOUNT	1-GANG W/ GROMMET	N/A	(E) 2-GANG DOUBLE-DEPTH BOX W/ 1-GANG REDUCER	N/A	HOME RUN TO AV RACK
VPJ	COMMISSIONERS BOARD ROOM	VIDEO PROJECTOR	N/A DIRECT CONNECT	N/A	(E) NEMA TYPE 1 6X6X6	N/A	HOME RUN TO AV RACK
SCRC	COMMISSIONERS BOARD ROOM	MOTORIZED SCREEN CONTROL	N/A DIRECT CONNECT	N/A	(E) 2-GANG DOUBLE-DEPTH BOX	N/A	HOME RUN TO AV RACK
SC	SEE DRAWINGS	CEILING MOUNT 70V LOUDSPEAKER	N/A DIRECT CONNECT	N/A	(E) 1-GANG W/ FLEX CONDUIT TO LOUDSPEAKER	N/A	FROM AV RACK - CONTINUES TO OTHER SIMILAR DEVICES IN AREA
CSP-2	COMMISSIONERS BOARD ROOM	CONTROL PANEL	PRE-MADE DEVICE	N/A	2-GANG MUD RING CUT INTO WALL	N/A	HOME RUN TO AV RACK
MLT	COMMISSIONERS BOARD ROOM	MUTE ON LIGHT	1-GANG W/ GROMMET	N/A	1-GANG MUD RING CUT INTO CEILING TILE	N/A	HOME RUN TO AV RACK

1 AV PANEL SCHEDULE

PRODUCTION SYSTEMS SCOPE MATRIX				
SCOPE	PROVIDED BY		INSTALLED BY	
	EC	AV	EC	AV
POWER SYSTEMS (COMPLETE)	X		X	
COMPANY SWITCHES	X		X	
CONDUIT FOR AV SYSTEM	X		X	
STANDARD GANG & DIMENSIONAL BACKBOXES	X		X	
FLOOR & WALL SPECIALTY BACKBOXES		X	X	
WIRE & PULL FOR AV SYSTEMS (LOW-VOLT ONLY)		X		X
WIRE TERMINATION FOR AV SYSTEMS		X		X
EQUIPMENT RACKS FOR AV		X		X
AV EQUIPMENT & INSTALLATION		X		X
AV TESTING, TUNING, CONFIGURATION		X		X

2 AV PRODUCTION SYSTEMS SCOPE MATRIX

ASSISTIVE LISTENING			
	# SEATS	# RECEIVERS / # HEARING AID	TYPE
COMMISSIONERS ROOM	142	6/2	IR

219.3 Receivers for Assistive Listening Systems <small>Department of Justice's ADA Standards for Accessible Design (2010)</small>		
Capacity of Seating in Assembly Area	Minimum Number of Required Receivers	Minimum Number of Required Receivers Required to be Hearing-Aid Compatible
50 or less	2	2
51 to 200	2, plus 1 per 25 seats over 50 seats ¹	2
201 to 500	2, plus 1 per 25 seats over 50 seats ¹	1 per 4 receivers ¹
501 to 1000	20, plus 1 per 33 seats over 500 seats ¹	1 per 4 receivers ¹
1001 to 2000	35, plus 1 per 50 seats over 1000 seats ¹	1 per 4 receivers ¹
2001 and over	55 plus 1 per 100 seats over 2000 seats ¹	1 per 4 receivers ¹

¹ Or fraction thereof.

3 ASSISTIVE LISTENING CALCULATIONS & REFERENCES

ASSISTIVE LISTENING CODE REFERENCES

- 219.2 Required Systems. In each assembly area where audible communication is integral to the use of the space, an assistive listening system shall be provided. EXCEPTION: Other than in courtrooms, assistive listening systems shall not be required where audio amplification is not provided.
- 219.3 Receivers. Receivers complying with 706.2 shall be provided for assistive listening systems in each assembly area in accordance with Table 219.3. Twenty-five percent minimum of receivers provided, but no fewer than two, shall be hearing-aid compatible in accordance with 706.2. EXCEPTIONS: 1. Where a building contains more than one assembly area and the assembly areas required to provide assistive listening systems are under one management, the total number of required receivers shall be permitted to be calculated according to the total number of seats in the assembly areas in the building provided that all receivers are usable with all systems. 2. Where all seats in an assembly area are served by an induction loop assistive listening system, the minimum number of receivers required by Table 219.3 to be hearing-aid compatible shall not be required to be provided.
- Advisory 706.1 General. Assistive listening systems are generally categorized by their mode of transmission. There are hard-wired systems and three types of wireless systems: induction loop, infrared, and FM radio transmission. Each has different advantages and disadvantages that can help determine which system is best for a given application. For example, an FM system may be better than an infrared system in some open-air assemblies since infrared signals are less effective in sunlight. On the other hand, an infrared system is typically a better choice than an FM system where confidential transmission is important because it will be contained within a given space.
- 703.7.2.4 Assistive Listening Systems. Assistive listening systems shall be identified by the International Symbol of Access for Hearing Loss complying with Figure 703.7.2.4. (signage by architect).

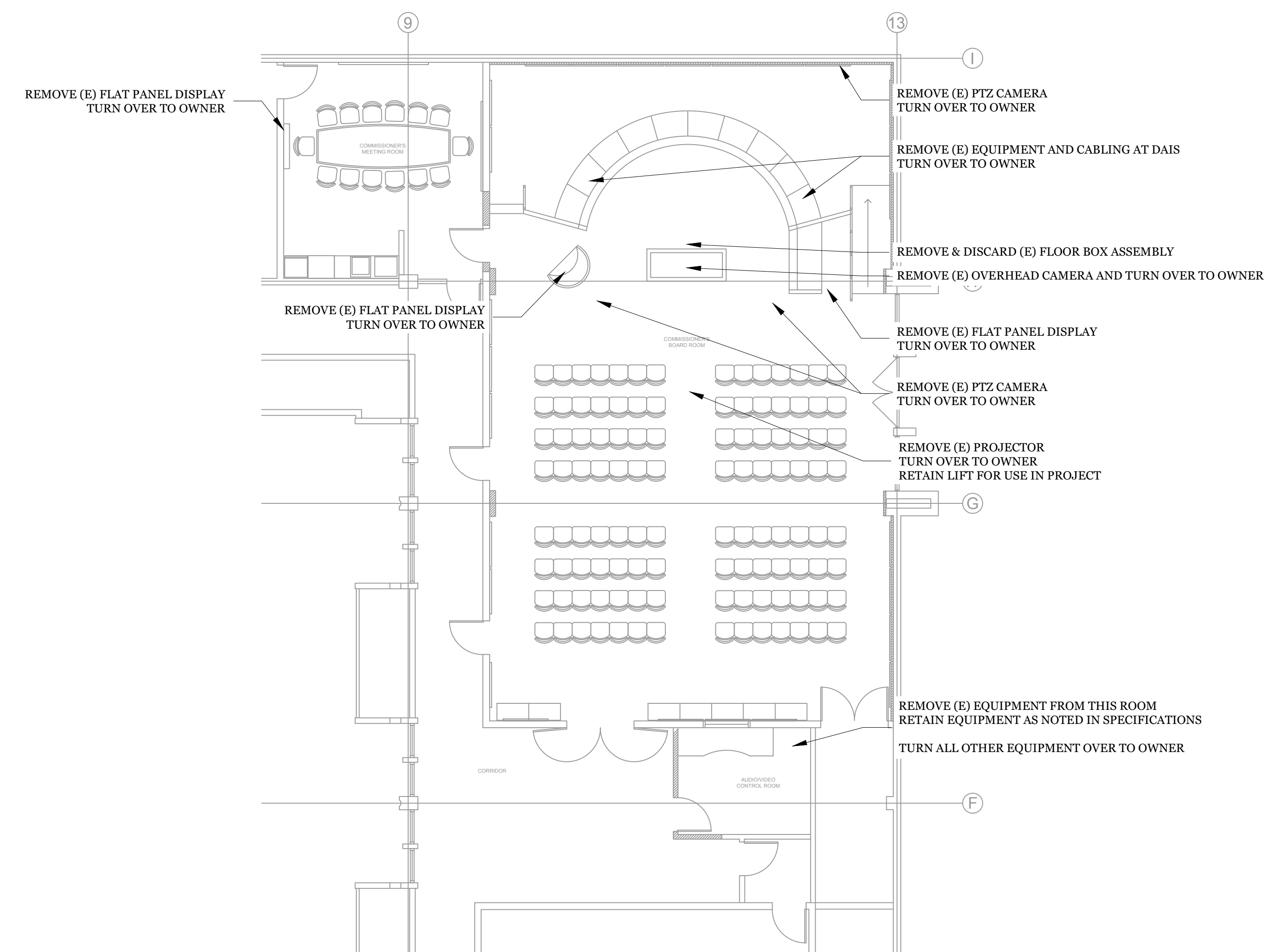

4 AV DEMO PLAN

The Shalleck Collaborative Inc.
 Planning and Design of Theatres Production Systems | AV
 1533 Martin Luther King Jr Way
 Berkeley, CA 94709
 415-956-4100 www.shalleck.com



OAKLAND HOUSING AUTHORITY - COMMISSIONER ROOM AV

2648 E. 14TH STREET, SUITE #801 OAKLAND, CA 94601

PROJECT # XX-XXX

MARK	DATE	DESCRIPTION
	12/10/20	100% DD
	01/08/21	95% CD
	02/03/21	100% CD

DRAWING TITLE
AV PANEL SCHEDULE & ALS INFORMATION

ISSUE DATE	DRAWING NO.
02-03-2021	AV001
DRAWN BY GTEH	
CHECKED BY IdH	

WIRETYPE SCHEDULE

- NOTES:
 1- WIRETYPES SHOWN BELOW ARE CURRENT TO OUR BEST KNOWLEDGE.
 2- MANUFACTURER SUBSTITUTIONS ARE ALLOWED, WITH APPROVAL FROM CONSULTANT.
 3- ALL CONDUIT, BACKBOXES AND JUNCTION BOXES BY ELECTRICAL CONTRACTOR.

TYPE	DESCRIPTION	DRY LOCATIONS EX: IN-WALL, CEILING, & CMD					WET LOCATIONS EX: IN-SLAB, IN-GRADE, OUTDOOR					NOTES
		MFR	MODEL	O.D.	AREA	RATING	MFR	MODEL	O.D.	AREA	RATING	
GROUP A - MIC LEVEL												
A1	Microphone Level Audio 22 AWG, 7x30 Stranding, Foil Shield	Belden	9451	0.135	0.0143	CMR	Belden	2451RW	0.158	0.0196	CMR	
GROUP B - LINE LEVEL												
B1	Line Level Audio 22 AWG, 7x30 Stranding, Foil Shield	Belden	9451	0.135	0.0143	CMR	Belden	2451RW	0.158	0.0196	CMR	
B2	Digital Audio - AES/EBU, 110-ohm 22 AWG, 7x30 Stranding, Foil Shield	Gepeco	DS401	0.180	0.0254	CMR	Sommer Cable	200-0241AQ	0.276	0.0598	CMR	
B3	Line Audio + DC Power 1-PR 22 AWG, 7x30 Stranding, Foil Shield 1-PR 18 AWG, 16x30 Stranding, Foil Shield	Belden	1502R	0.250	0.0491	CMR	Liberty	LLINX-U-DB	0.275	0.0549	DB	Runs Under 300'
B3B	Line Audio + DC Power 1-PR 22 AWG, 7x30 Stranding, Foil Shield 1-PR 14 AWG, 16x30 Stranding, Foil Shield	Sommer Cable	500-0101-1	0.291	0.0665	CMR	Belden	(1) 2451RW & (1) 5000U1	0.158 & 0.320	0.0196 & 0.0804	N/A	Runs Over 300'
GROUP C - VIDEO, NETWORK, & RF LEVEL												
C1	Party-Line Intercom, 1 CH 20 AWG, 7x28 Stranding, Foil Shield	Belden	8762	0.204	0.0327	CM	West Penn	AQC292	0.220	0.0380	CL3	Runs Under 500'
C1B	Party-Line Intercom, 1 CH 18 AWG, 16x30 Stranding, Foil Shield	Belden	8760	0.222	0.0387	CM	West Penn	AQ293	0.310	0.0754	CL3	Runs Over 500'
C1C	Digital Intercom, 1 CH 20 AWG, 7x28 Stranding, Foil Shield	Belden	9207	0.330	0.0855	CMG	West Penn	AQC292	0.220	0.0380	CL3	Helix-Net 1 Channel
C2	Party-Line Intercom, 2 CH 22 AWG, 7x30 Stranding, Foil Shield, 2 Pair	Belden	1814R	0.330	0.0855	CMR	West Penn	AQC430	0.250	0.0491	CL3	
C3	Party-Line Intercom, 4 CH 22 AWG, 7x30 Stranding, Foil Shield, 4 Pair	Belden	1815R	0.384	0.1158	CMR	West Penn	AQC439	0.427	0.1431	CL3	
C3B	Digital Intercom, Multi-CH 24 AWG, Solid, Foil Shield, 4 Pair, Cat5e, F/UTP	Belden	1533R	0.260	0.0531	CMR	Belden	7937A	0.276	0.0598	DB	Helix-Net Multi Channel
C5	Ethernet Data, Cat 6A, Single Foil Shield, F/UTP 23 AWG, Solid, Bonded Pairs	Belden	10GX62F	0.300	0.0707	CMR	Belden	2141A	.370	0.1075	CM-LS	
C6	Crestron / AMX Control 22 AWG, 7x30 Stranded, Foil Shield, (DATA) 18 AWG, 16x30 Stranded, (Power)	Liberty	LLINX-U	0.246	0.0475	CMG	Liberty	LLINX-U-DB	0.275	0.0549	DB	
C7	DC Control, 2 Conductor 18 AWG, 16x30 Stranded, Twisted Pair	Belden	9740	0.210	0.0346	CMG	West Penn	AQ224	0.270	0.0572	CL3	
C8	DC Control, 4 Conductor 18 AWG, 16x30 Stranded, Twisted Pair	Belden	9156	0.333	0.0870	CMG	West Penn	AQ244	0.327	0.0839	CL3	
C9	CATV Video 18 AWG, Solid Conductor, Braided Shield, RG-6 Type	Belden	9116	0.270	0.0572	CM, CATV	West Penn	AQC841	0.275	0.0594	CL3	
C10	Production Video 20 AWG, Solid Conductor, Braided Shield, RG-59 Type	Belden	1505A	0.233	0.0426	CMR	Belden	88281	0.271	0.0577	CMP	Runs Under 500'
C10B	Production Video 18 AWG, Solid Conductor, Braided Shield	Belden	1694A	0.274	0.0589	CMR	Belden	1694WB	0.274	0.0589	CMR	Runs Over 500'
C10C	Production Video 16 AWG, Solid Conductor, Braided Shield	Belden	4794R	0.320	0.0804	CMR	NO KNOWN OPTION					
C12	Wireless Antenna 10 AWG, Solid Conductor, Braided Shield, RG-8/U, 50Ω	Time Microwave systems	LMR-400-FR	0.405	0.1288	CMR	Time Microwave Systems	LMR-400-DB	0.405	0.1288	DB	
C14	Infrared Emitter 19 AWG, Solid Conductor, Braided Shield	Time Microwave systems	LMR-200-FR	0.195	0.0298	CMR	Time Microwave Systems	LMR-200-DB	0.195	0.0298	DB	Runs Under 100'
C15	Extron XTP/DTP shielded 4-Twisted Pair	Extron	XTP DTP 24	0.276	0.0598	CM	NO KNOWN OPTION					
C19	Digital Media Cable, 8G Shielded 4 Twisted	Crestron	DM-CBL-8G-NP	0.244	0.0467	CMR	NO KNOWN OPTION					Use DM-8G-CONN Connector
GROUP D - LOUDSPEAKER LEVEL												
D1	Loudspeaker, 2 Conductor 12 AWG, 65x30 Stranded	Belden	5000UP	.312	0.0764	CL3	Belden	5000U1	0.320	0.0804	WB	
D2	Loudspeaker, 4 Conductor 12 AWG, 65x30 Stranded	Belden	5002UP	0.365	0.1046	CL3	Belden	5002U1	0.377	0.1116	WB	
D3	Loudspeaker, 70 Volt, 2 Conductor 18 AWG, 7x26 Stranded	West Penn	224	0.156	0.0191	CMR	West Penn	AQ224	0.270	0.0572	CL3	
D4	Loudspeaker, 70 Volt, 4 Conductor 18 AWG, 7x26 Stranded	West Penn	244	0.183	0.0253	CMR	West Penn	AQ244	0.327	0.0839	CL3	
GROUP E - EMPTY CONDUIT												
E	NO WIRETYPE, FOR FUTURE EXPANSION											
GROUP F - FIBER OPTIC LEVEL												
F3	Single-Mode Fiber, 2-strand 1310 μm, OS2, OFNR	Belden	FISD002R9	0.184	0.0266	OFNR	Belden	FSSL002NF	0.184	0.0266	OFNR	
F5	Multi-Mode Fiber, 2-strand, OM3 50/125 MM, DUPLEX, OFNR	Belden	FL4D002R9	0.184	0.0266	OFNR	Belden	FS2H002NF	0.184	0.0266	OFNR	

1 AV WIRETYPE SCHEDULE
NTS

	A	B	C	D	E
A	--	12"	12"	12"	12"
B	12"	--	6"	6"	6"
C	12"	6"	--	6"	6"
D	12"	6"	6"	--	6"
E	12"	6"	6"	6"	--

CONDUIT SEPARATION NOTES

- THE AV SPECIFIC CONDUIT SEPARATION TABLE ABOVE REFLECTS BEST-CASE SCENARIOS, AND SHOULD BE ADHERED TO WHEN POSSIBLE.
- ABSOLUTE MINIMUM SEPARATION FOR AV CONDUIT IS 4", IF ABOVE DISTANCES ARE NOT ACHIEVABLE.
- ABSOLUTE MINIMUM SEPARATION BETWEEN AV AND ELECTRICAL POWER CONDUITS IS 36"

	AV CONDUIT
AC BRANCH LOAD	36"
AC-FEEDER	48"
AC-DIMMED LOAD	36"
TEL/DATA	12"
CONTROL (OTHER)	12"

EXCEPTIONS

- SHOULD ELECTRICAL CONDUIT NEED TO CROSS AV CONDUIT, DO SO AT 90-DEGREES.
- IF AV CONDUIT MINIMUM SEPARATION CANNOT BE MET (SUCH AS WHEN GOING THROUGH A NARROW CAVITY), CONDUIT MAY RUN IMMEDIATELY ADJACENT FOR NO MORE THAN 3'-0" IN ANY 50'-0" SPAN.

2 CONDUIT SEPARATION TABLES
NTS

AV CONDUIT TYPE	MAX RUN LENGTH
A	500'
B	500'
C	250'
D	500'
E	250'
F	5000'

CONDUIT RUN LENGTH LIMIT NOTES

- C-TYPE CONDUIT CONTAINS IP BASED NETWORK CONNECTIONS THAT CAN NOT EXCEED 250'
- IF CONDUIT RUN LENGTHS CAN NOT BE MAINTAINED, CONTRACTOR MUST SUBMIT RUN LENGTH FOR APPROVAL.

3 CONDUIT RUN LENGTH LIMITS
NTS

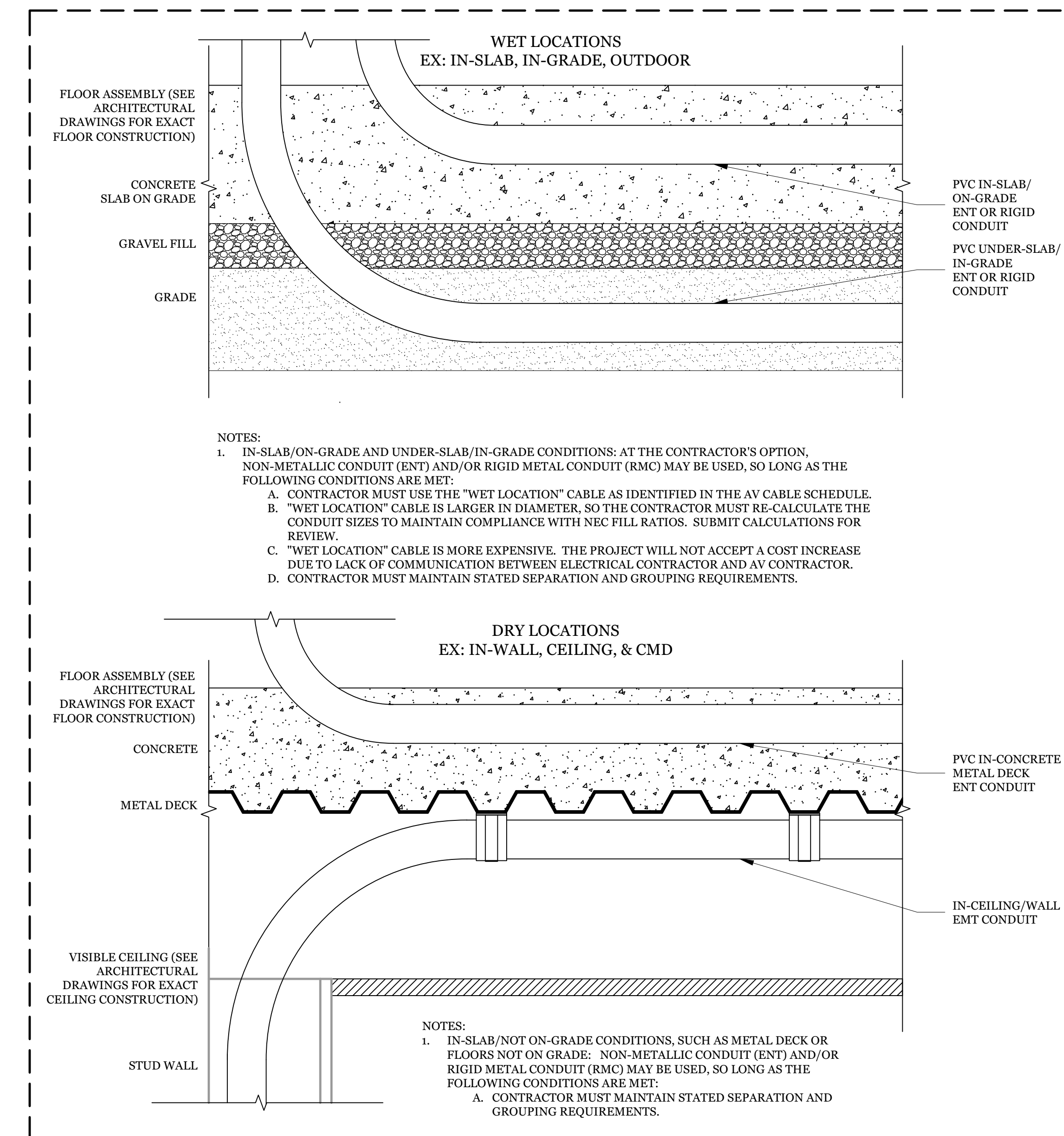

3 WET/DRY CABLE SELECTION GUIDELINES
NTS

The Shalleck Collaborative Inc.
 Planning and Design of Theatres
 Production Systems | AV
 1633 Martin Luther King Jr Way
 Berkeley, CA 94709
 415-956-4100 www.shalleck.com



OAKLAND HOUSING AUTHORITY - COMMISSIONER ROOM AV

2648 E. 14TH STREET,
 SUITE #801
 OAKLAND, CA 94601

PROJECT # XX-XXX

MARK	DATE	DESCRIPTION
	12/10/20	100% DD
	01/08/21	95% CD
	02/03/21	100% CD

DRAWING TITLE
 AV WIRETYPE SCHEDULE

ISSUE DATE 02-03-2021	DRAWING NO.
DRAWN BY GTEH	AV002
CHECKED BY IdH	

E
D
C
B
A

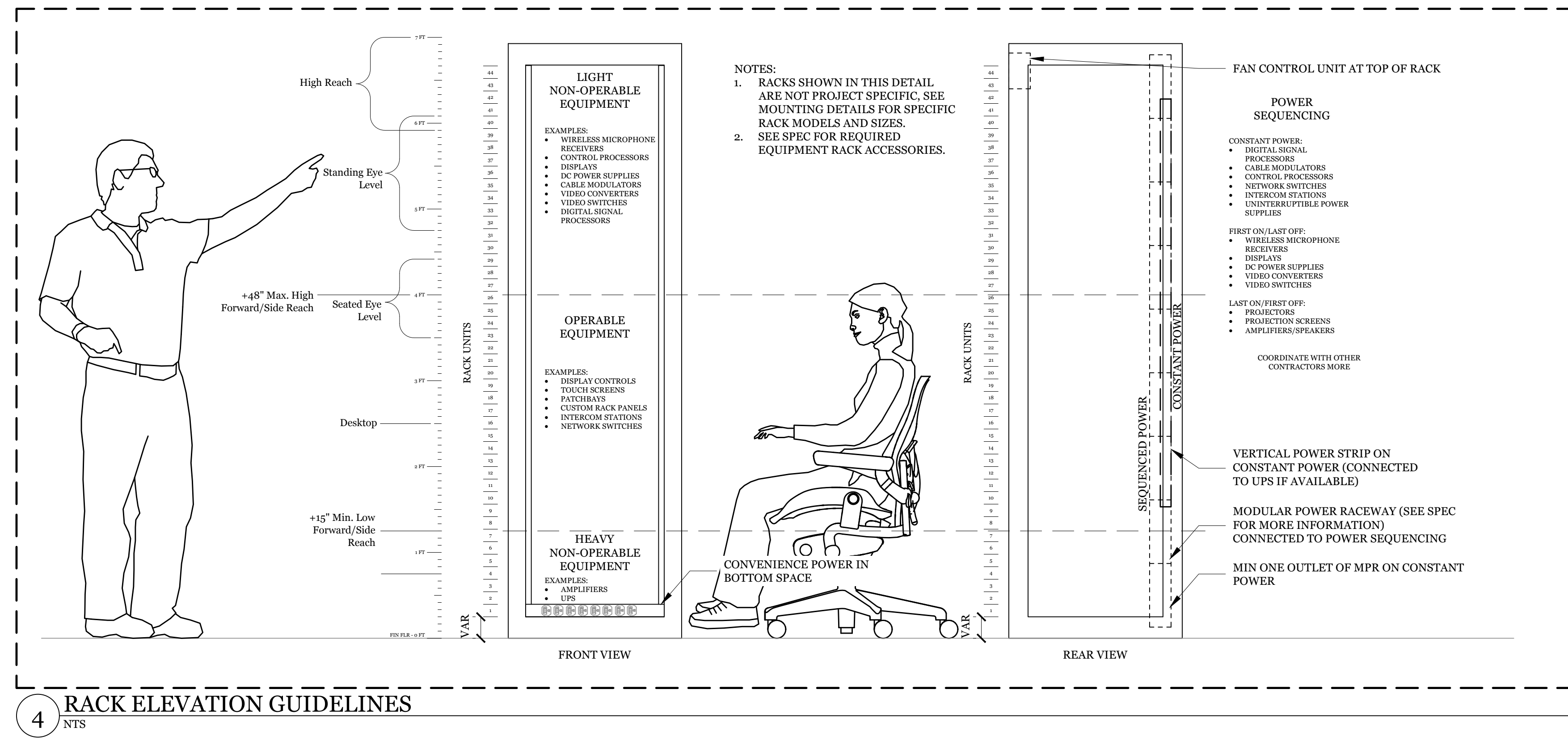
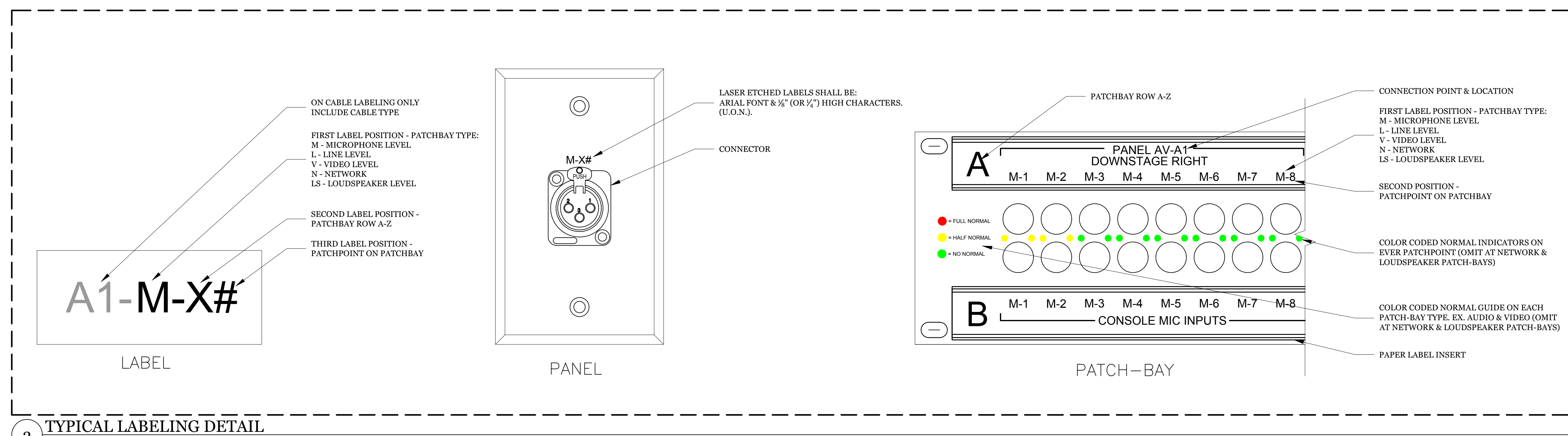
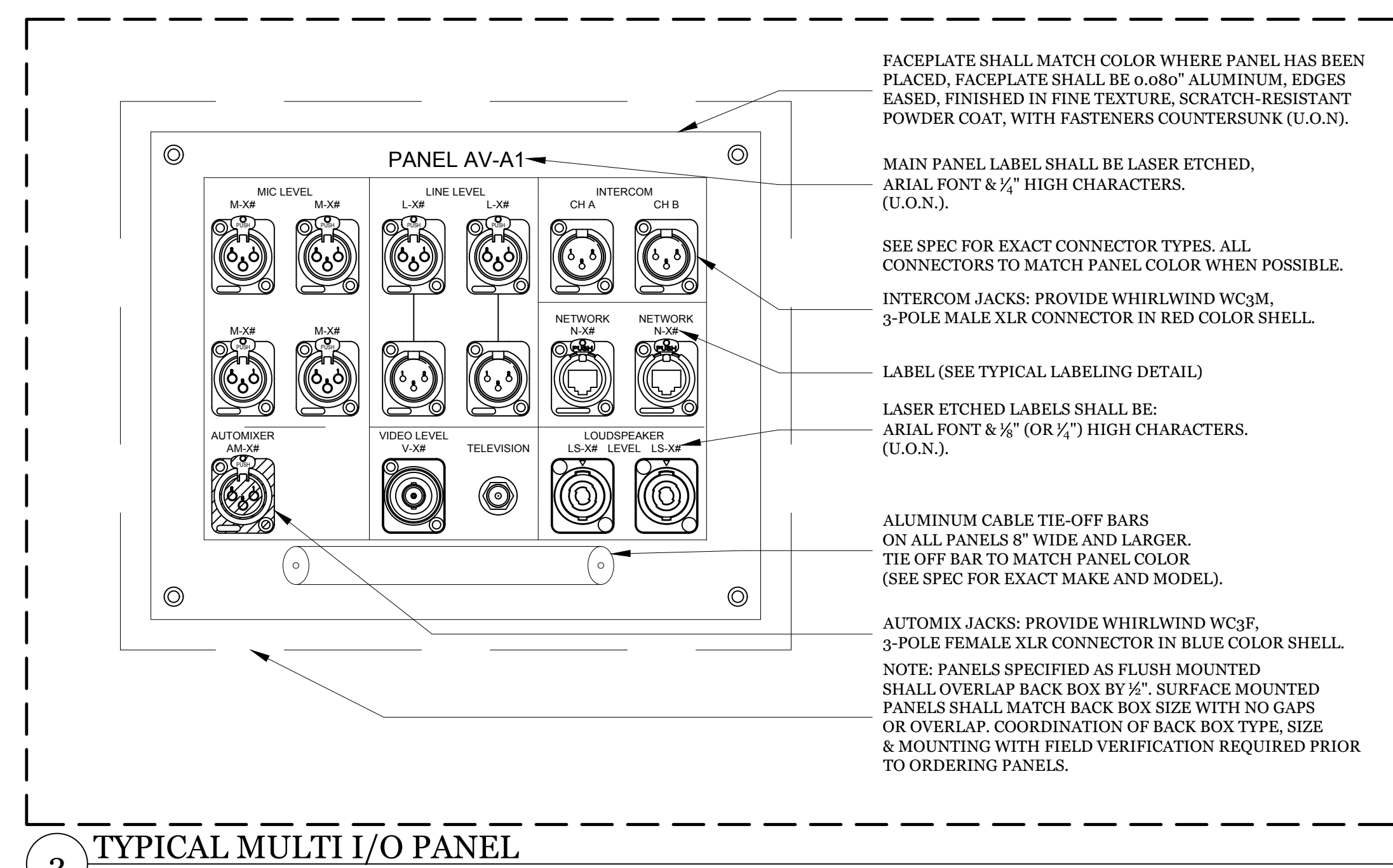
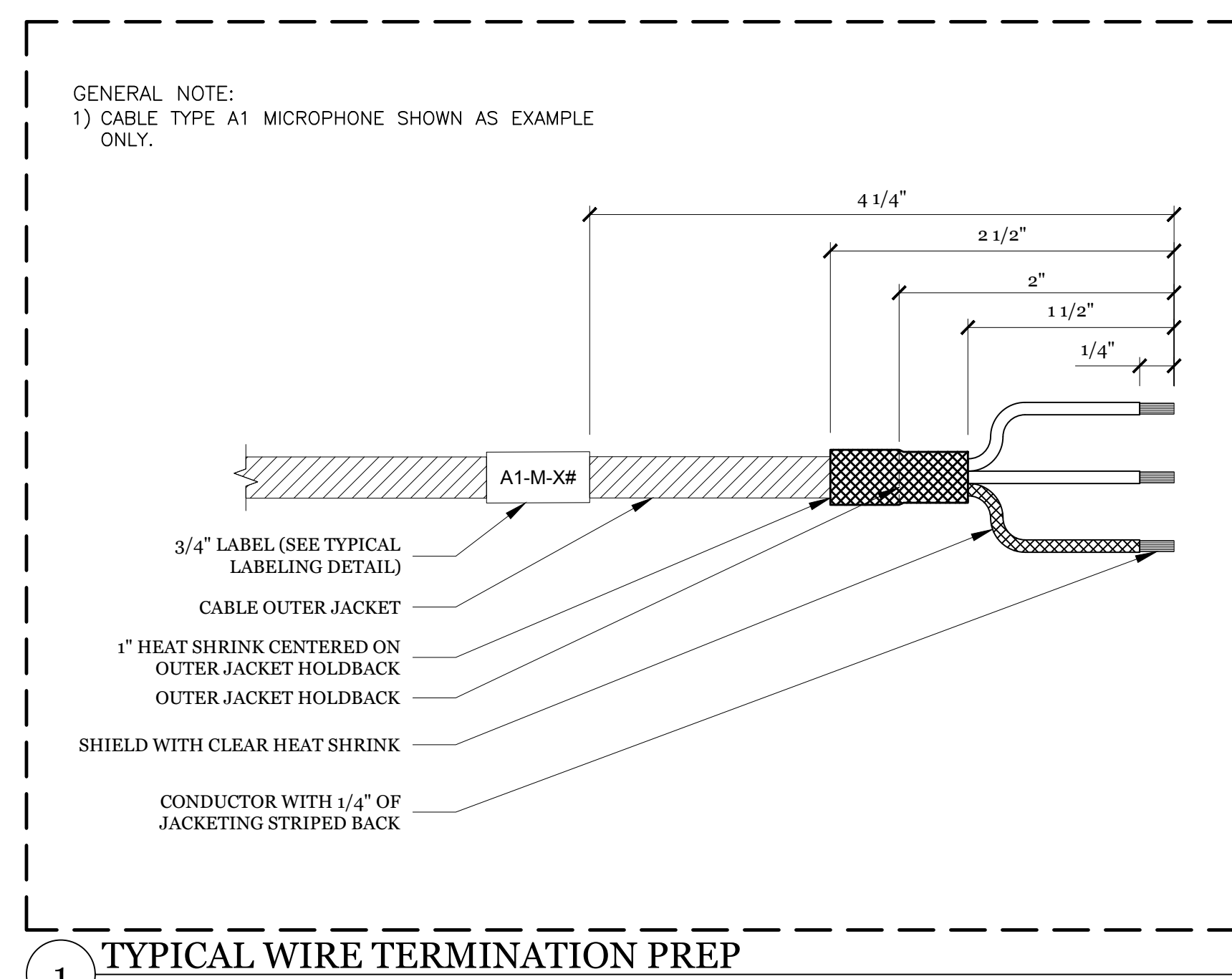

The Shalleck Collaborative Inc.
Planning and Design of Theatres Production Systems | AV
1533 Martin Luther King Jr Way
Berkeley, CA 94709
415-956-4100 www.shalleck.com



Oakland Housing Authority

OAKLAND HOUSING AUTHORITY - COMMISSIONER ROOM AV

2648 E. 14TH STREET, SUITE #801 OAKLAND, CA 94601

PROJECT # XX-XXX

MARK	DATE	DESCRIPTION
	12/10/20	100% DD
	01/08/21	95% CD
	02/03/21	100% CD

DRAWING TITLE
AV PANEL SCHEDULES

ISSUE DATE 02-03-2021	DRAWING NO.
DRAWN BY GTEH	AV002
CHECKED BY IdH	

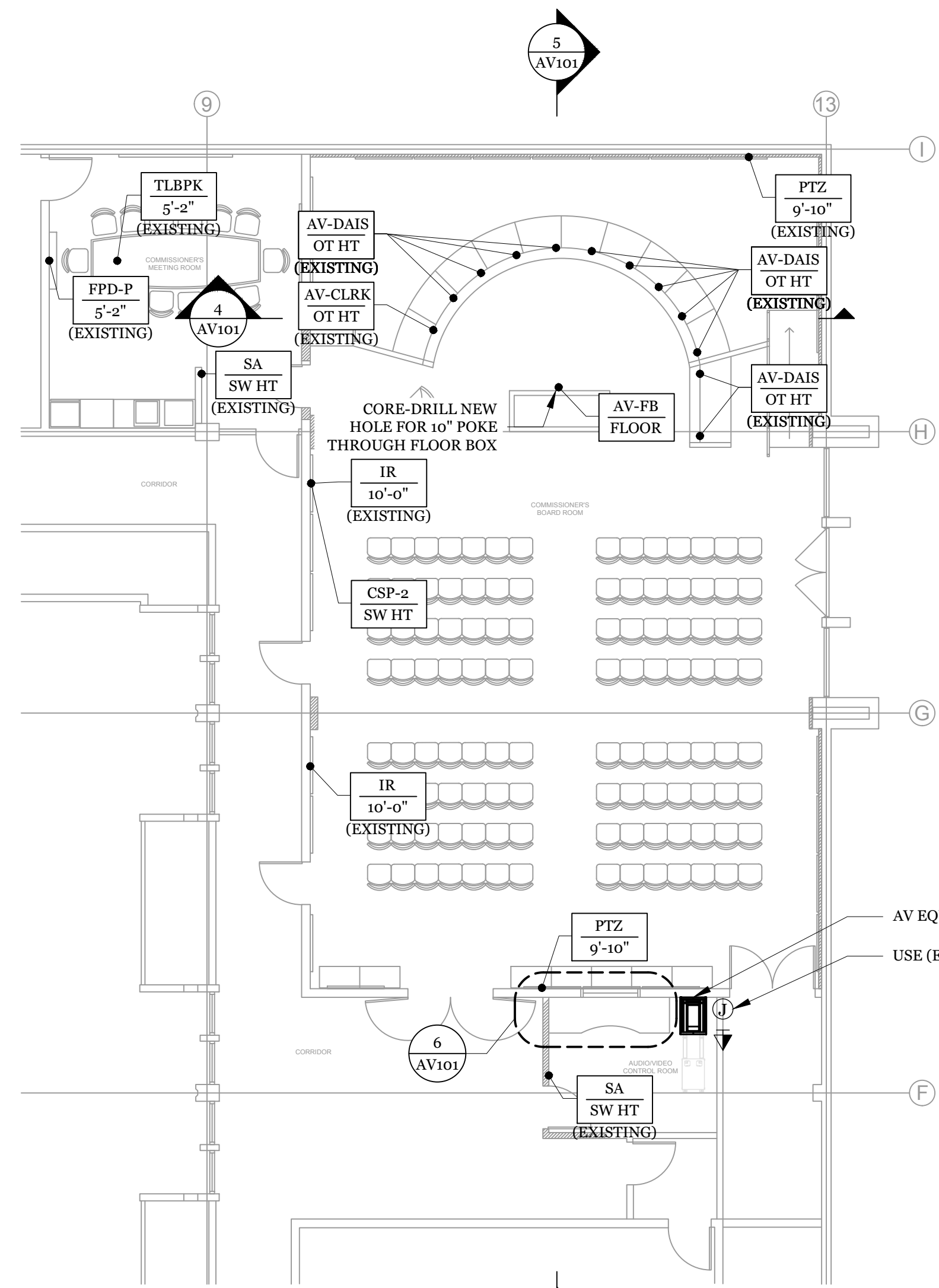

1 AV DEVICE PLAN AT LEVEL 1
1/8"=1'-0"

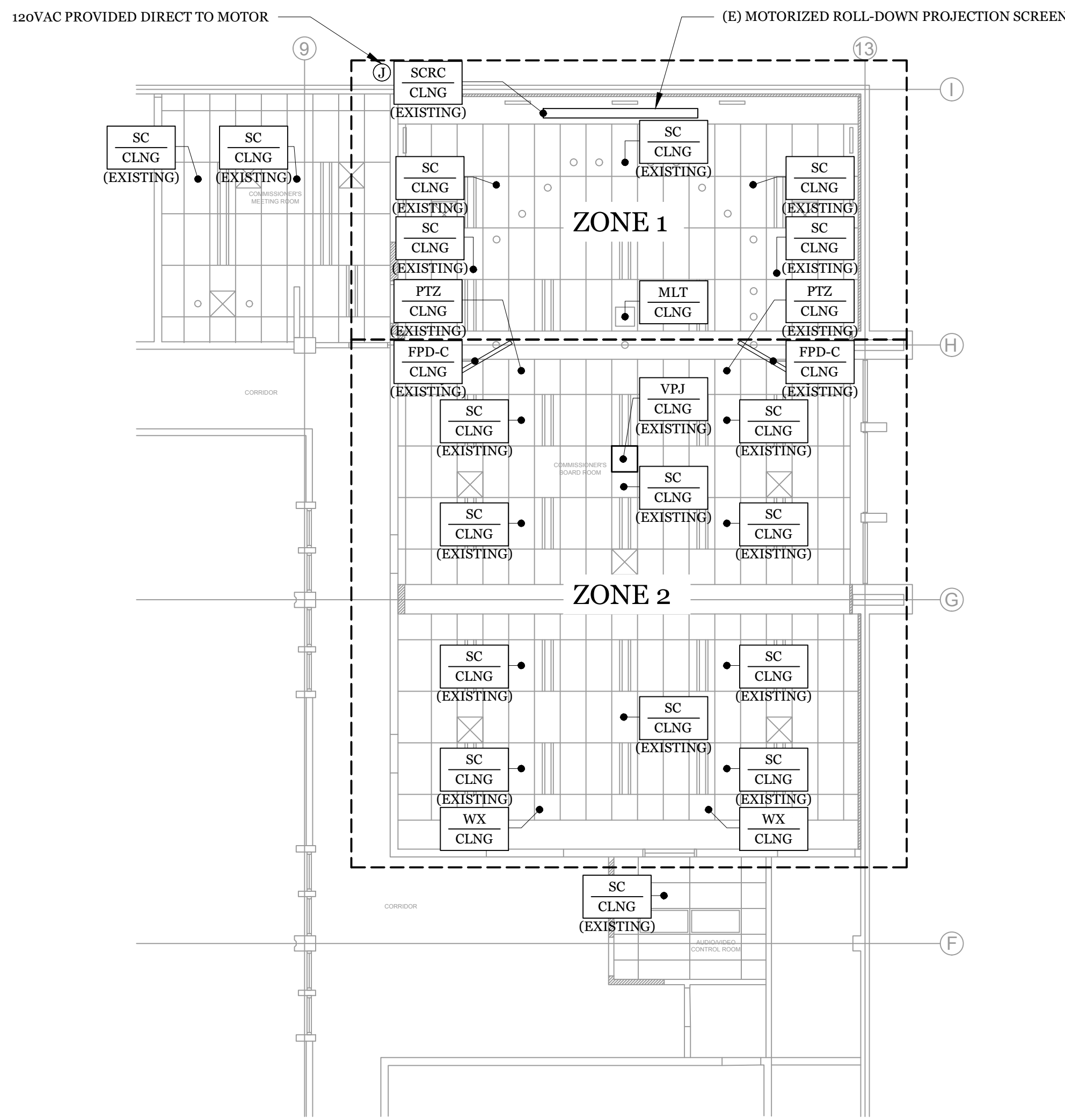

2 AV DEVICE RCP AT LEVEL 1
1/8"=1'-0"

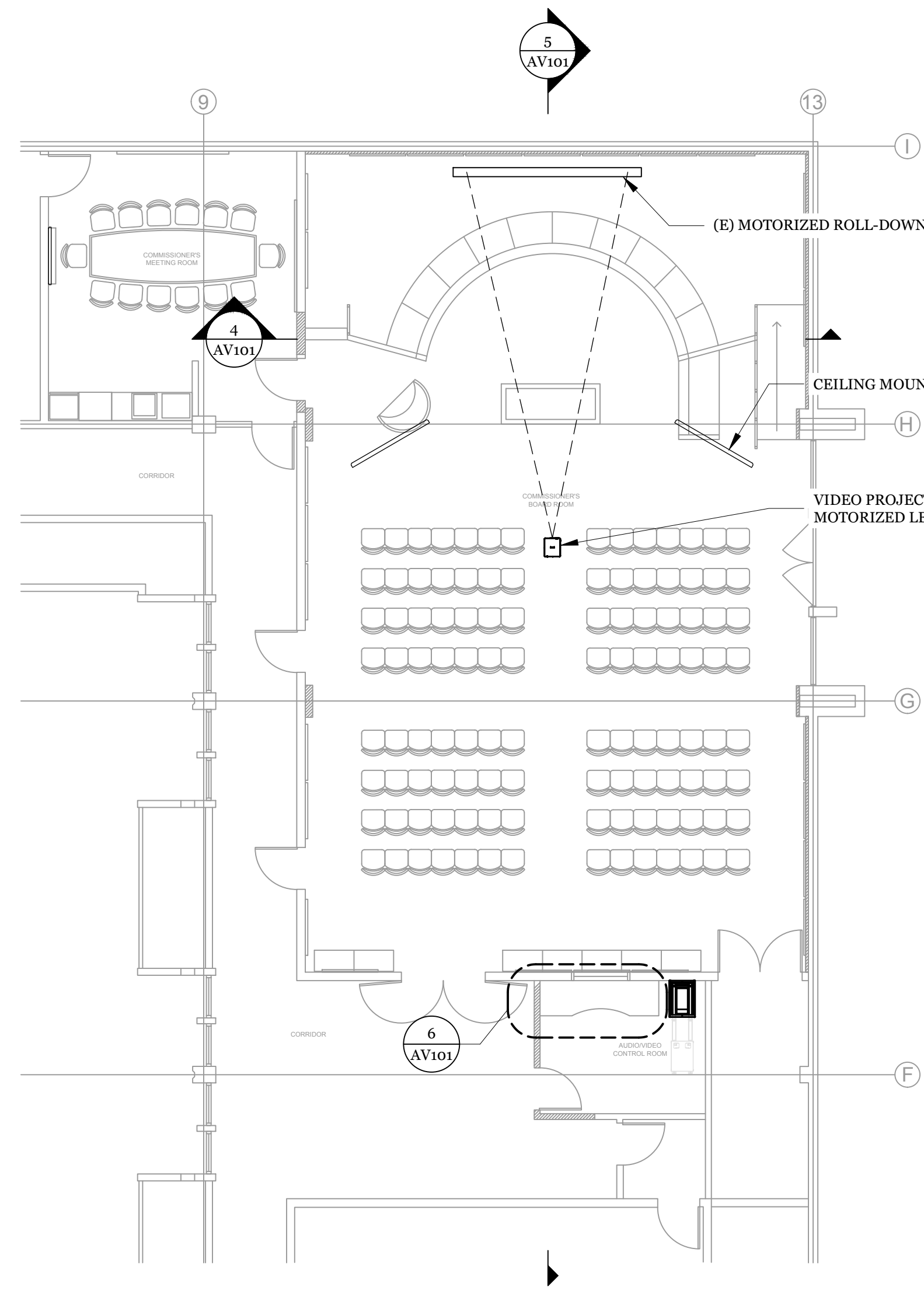

3 VIDEO PLAN AT COMMISSIONERS BOARD ROOM
1/8"=1'-0"

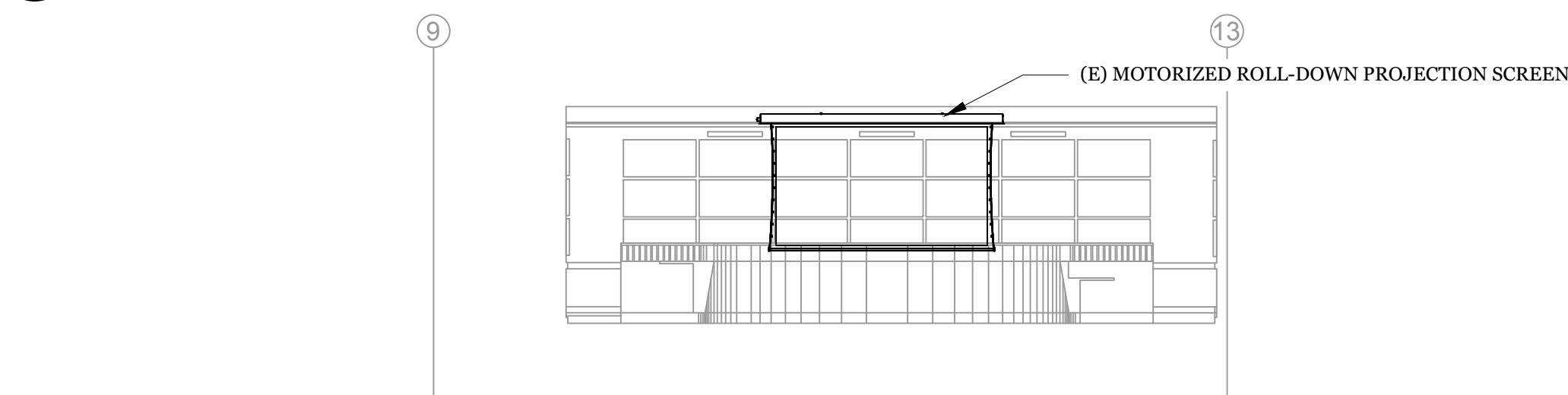

4 VIDEO ELEVATION AT COMMISSIONERS BOARD ROOM
1/8"=1'-0"

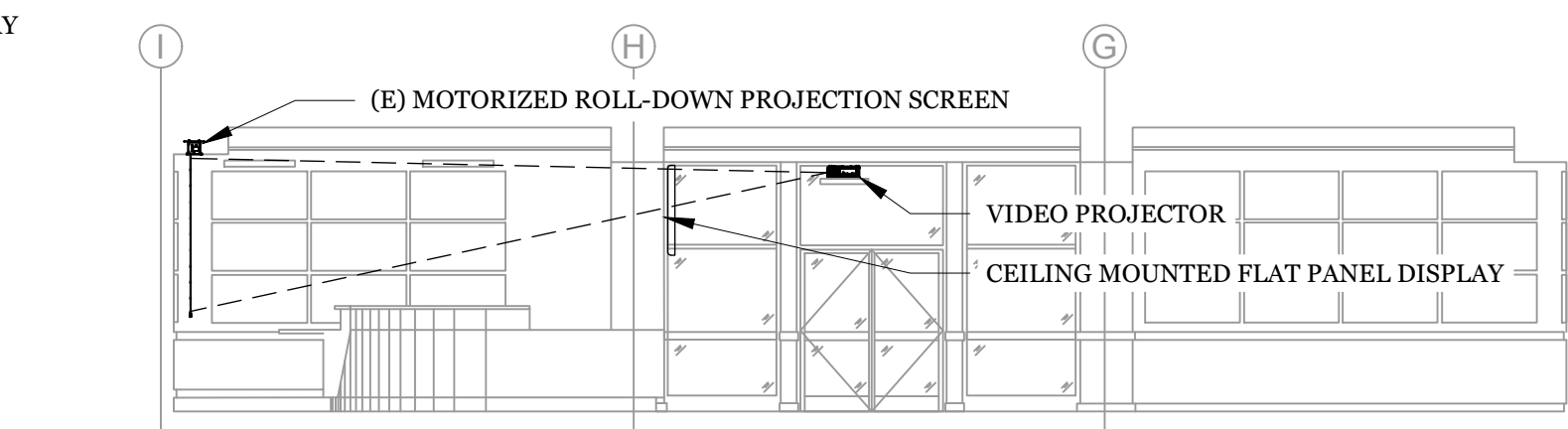

5 VIDEO SECTION AT COMMISSIONERS BOARD ROOM
1/8"=1'-0"

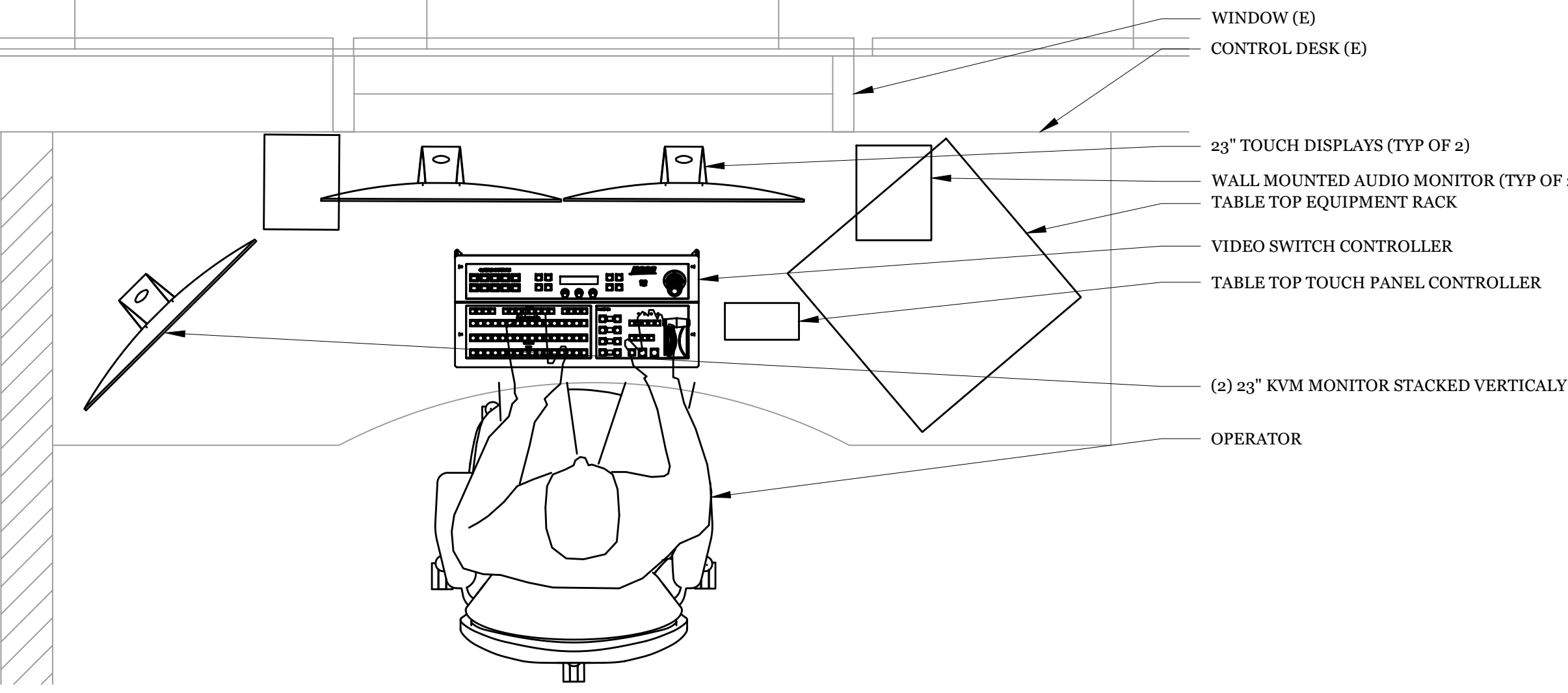

6 CONTROL OPERATORS DESK DETAIL PLAN
1"=1'-0"

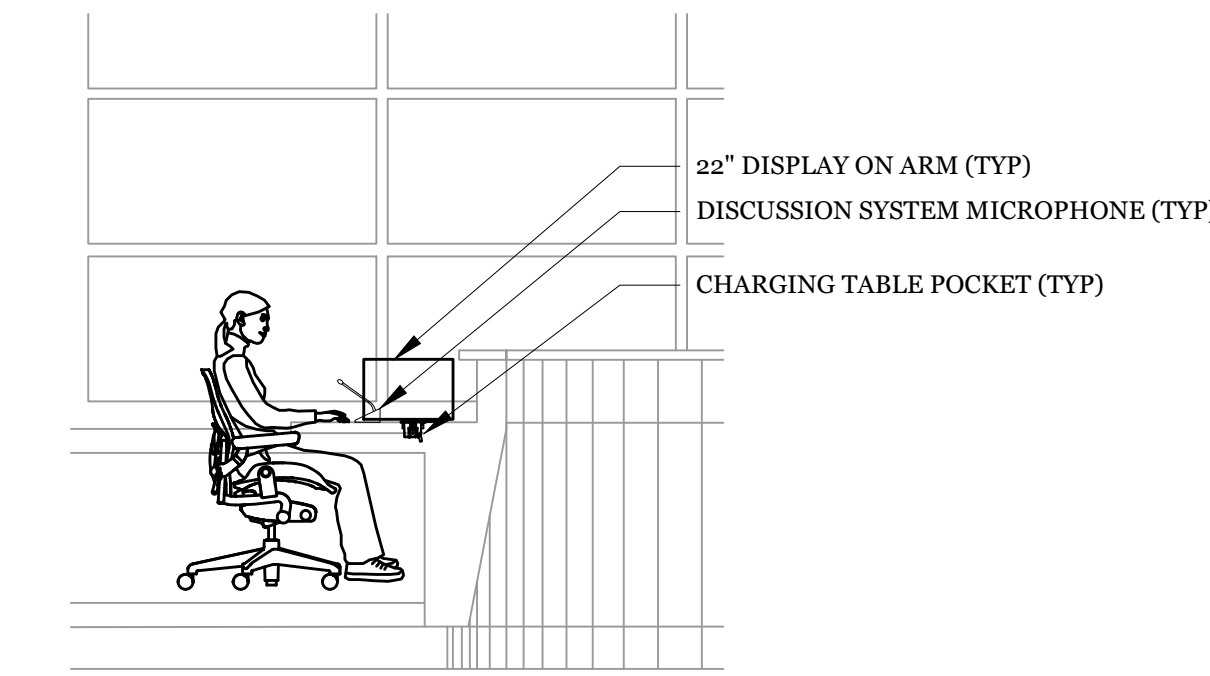

8 DAIS DETAIL SECTION
3/8"=1'-0"

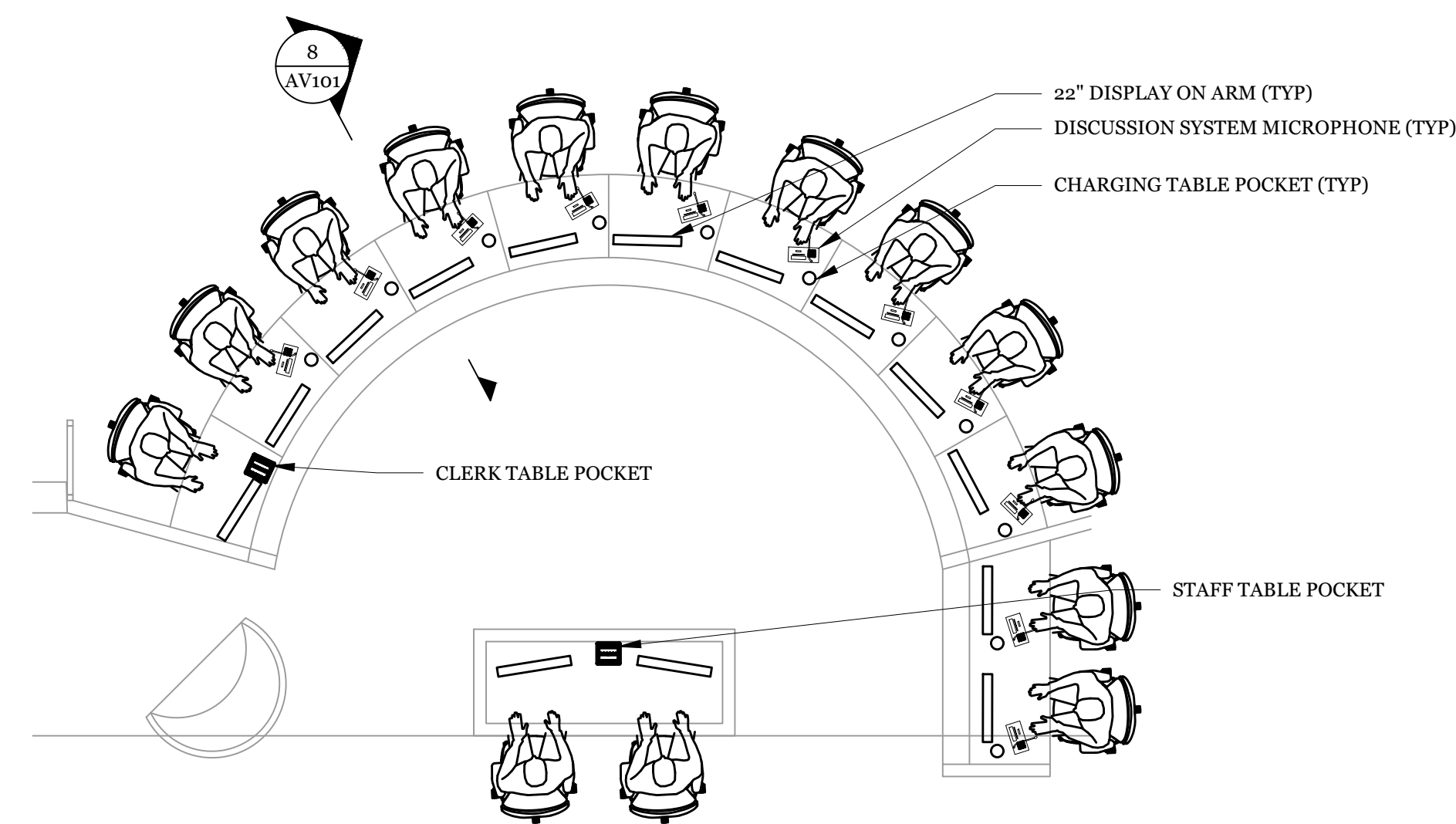

7 DAIS DETAIL PLAN
1/4"=1'-0"

AV SYMBOL KEY

DEVICE LOCATION
AV PANEL TYPE

XXX
X'-X"

MOUNTING
CONDITION OR HEIGHT TO CENTER OF BACKBOX

SW HT: PROJECT STANDARD SWITCH HEIGHT
OT HT: PROJECT STANDARD OUTLET HEIGHT
CLNG: CEILING MOUNT
A/R: AS REQUIRED

AUDIO

- AV-XX: CUSTOM AV PANEL & LOCATION
- IR: IR ASSISTIVE LISTENING ANTENNA
- WX: WIRELESS MICROPHONE ANTENNA

VIDEO

- VPJ: VIDEO PROJECTOR
- FPD-P: FLAT PANEL VIDEO DISPLAY W/ PULL-OUT MOUNT
- FPD-C: FLAT PANEL VIDEO DISPLAY W/ CEILING MOUNT
- TLBK: TABLE POCKET
- PTZ: PAN TILT ZOOM CAMERA

LOUDSPEAKER

- SA: 70V VOLUME CONTROL
- SC: CEILING MOUNT 70V LOUDSPEAKER

CONTROL

- SCRC: MOTORIZED ROLL-DOWN SCREEN CONTROL
- CSP-2: TOUCH SCREEN CONTROL PANEL
- MLT: MUTE LIGHT

LOOSE CONNECTION TO PANEL
A/V EQUIPMENT TYPE

XXX
XXX

MOUNTING
CONDITION

AUDIO

- MIC: MICROPHONE

VIDEO

- VCAM: VIDEO CAMERA
- VPJ: VIDEO PROJECTOR

LOUDSPEAKER

- LS: LOUDSPEAKER
- SUB: SUBWOOFER
- PS: PAGING SPEAKER

ELECTRICAL

- ⊕ DUPLX OUTLET, 120V / 20A (BY ELEC)
- ⊕ QUAD OUTLET, 120V / DUAL 20A (BY ELEC)
- ⊕ SPECIALTY OUTLET (SEE DESCRIPTION) (BY ELEC)
- ⊕ JUNCTION BOX (SEE DESCRIPTION) (BY ELEC)
- ⊕ CATV OUTLET (BY ELEC)
- ⊕ TEL/DATA OUTLET (BY ELEC)

GENERAL NOTES

- ALL AC OUTLETS, CONDUIT & BACKBOXES BY ELECTRICAL ENGINEER.
- REQUIRED STRUCTURAL BACKING BY STRUCTURAL ENGINEER.
- A/V CONTRACTOR TO COORDINATE WITH ELECTRICAL TO DETERMINE EXACT LOCATION OF A/V BACKBOXES.
- ALL VISIBLE LOUDSPEAKERS & PANELS SHALL BE PROVIDED IN A COLOR AS DETERMINED BY THE ARCHITECT DURING THE SHOP DRAWING PHASE. COORDINATE EXACT MOUNTING CONDITIONS WITH ARCHITECT, STRUCTURAL ENGINEER & GENERAL CONTRACTOR.

The Shalleck Collaborative Inc.
Planning and Design of Theatres
Production Systems | AV
1553 Martin Luther King Jr Way
Berkeley, CA 94709
415-956-4100 www.shalleck.com



OAKLAND HOUSING AUTHORITY - COMMISSIONER ROOM AV

2648 E. 14TH STREET, SUITE #801 OAKLAND, CA 94601

MARK	DATE	DESCRIPTION
	12/10/20	100% DD
	01/08/21	95% CD
	02/03/21	100% CD

DRAWING TITLE
AV DEVICE PLAN AT LEVEL 1

ISSUE DATE	DRAWING NO.
02-03-2021	AV101
DRAWN BY GTEH	
CHECKED BY IdH	

E
D
C
B
A

1 2 3 4 5 6

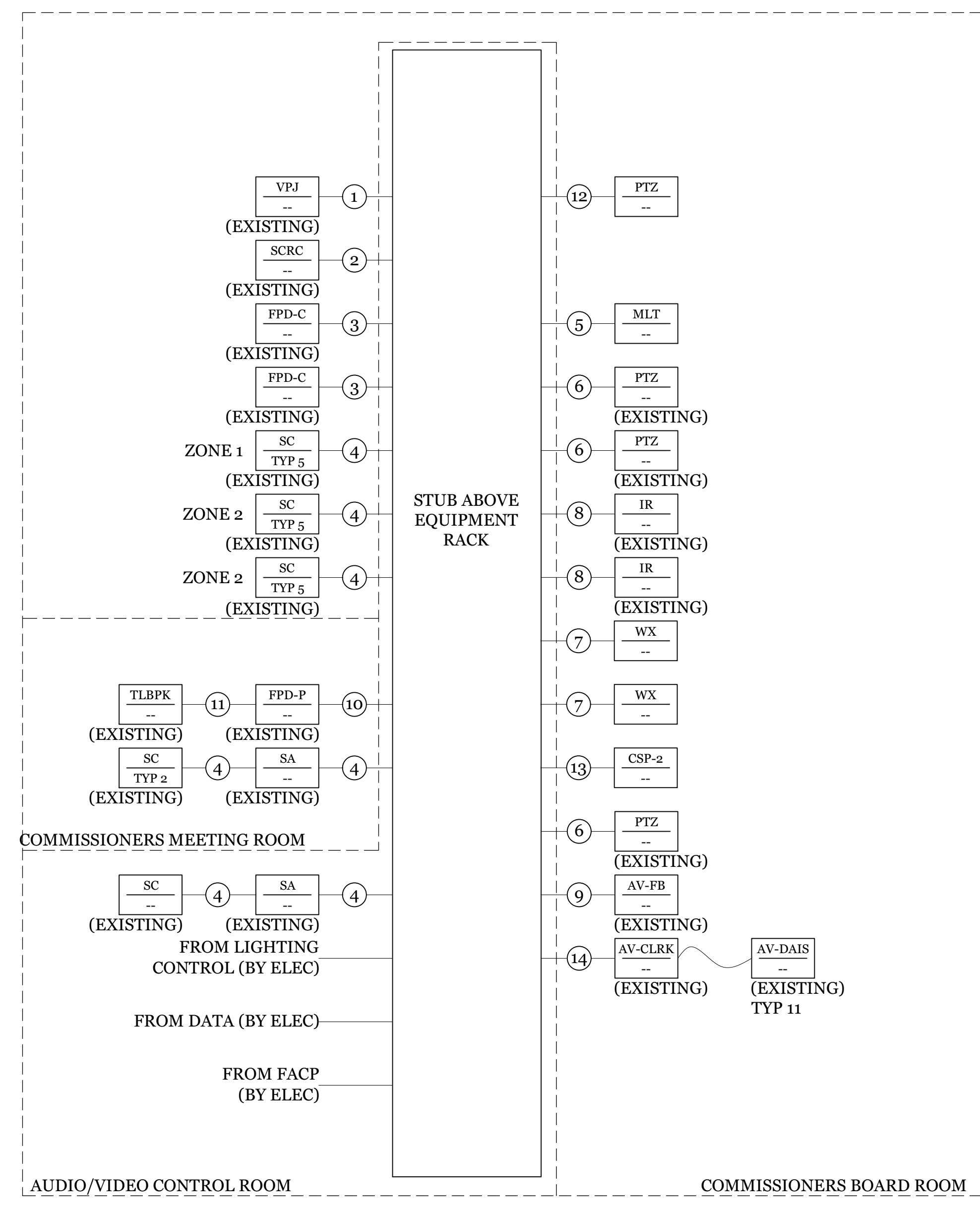

WIRE & CONDUIT TABLE					
RUN NUMBER	WIRE QTY	WIRE TYPE	CONDUIT QTY	CONDUIT SIZE	NOTES
1	2	C5 CtoC	(EXISTING)	(EXISTING)	CONFIRM WIRE WILL FIT IN (E) CONDUIT
2	1	C8	(EXISTING)	(EXISTING)	CONFIRM WIRE WILL FIT IN (E) CONDUIT
3	2	C5	(EXISTING)	(EXISTING)	CONFIRM WIRE WILL FIT IN (E) CONDUIT
4	1	D3	(EXISTING)	(EXISTING)	CONFIRM WIRE WILL FIT IN (E) CONDUIT
5	1	C6	(EXISTING) REUSE CONDUIT FOR (E) DOC CAMERA	(EXISTING) REUSE CONDUIT FOR (E) DOC CAMERA	CONFIRM WIRE WILL FIT IN (E) CONDUIT
6	1 1 2	C5 C7 CtoC	(EXISTING)	(EXISTING)	CONFIRM WIRE WILL FIT IN (E) CONDUIT
7	1	C12	FREE AIR ABOVE CEILING	FREE AIR ABOVE CEILING	
8	1	C14	(EXISTING)	(EXISTING)	CONFIRM WIRE WILL FIT IN (E) CONDUIT
9	1 2 1 6 2 1	A1 B1 B3 C5 CtoC TADDEN 6-PIN	(EXISTING)	(EXISTING)	CONFIRM WIRE WILL FIT IN (E) CONDUIT
10	1 4	C9 C5	(EXISTING)	(EXISTING)	CONFIRM WIRE WILL FIT IN (E) CONDUIT
11	2 1	C5 HDMI	(EXISTING)	(EXISTING)	CONFIRM WIRE WILL FIT IN (E) CONDUIT
12	1 1 2	C5 C7 CtoC	FREE AIR ABOVE CEILING	FREE AIR ABOVE CEILING	
13	1	C5	FREE AIR ABOVE CEILING	FREE AIR ABOVE CEILING	
14	2 2 7 2 2	A1 B1 C5 CtoC TADDEN 6-PIN	(EXISTING)	(EXISTING)	CONFIRM WIRE WILL FIT IN (E) CONDUIT

5 AV WIRE AND CONDUIT RISER DIAGRAM
NTS

AV WIRE RISER NOTES & KEY

- WIRES OF SIMILAR WIRETYPE CLASSIFICATION (A, B, C, D or E) MAY BE COMBINED INTO A SINGLE CONDUIT.
- MINIMUM CONDUIT SIZE IS 3/4".
- CONDUIT SIZE TO BE VERIFIED IN WRITING BY AV CONTRACTOR WITHIN 30 DAYS OF CONTRACT AWARD.
- ALL CONDUIT & BACKBOXES BY ELECTRICAL.
- FOLLOW CONDUIT SEPARATION TABLES & CONDUIT RUN LENGTH TABLES AS INDICATED ON KEY SHEET & IN SPECIFICATIONS.
- INCREASE CONDUIT TO NEXT SIZE UP FOR RUNS GREATER THAN 50'-0" WITHOUT A JUNCTION BOX.

The Shalleck Collaborative Inc.
 Planning and Design of Theatres
 Production Systems | AV
 1553 Martin Luther King Jr Way
 Berkeley, CA 94709
 415-956-4100 www.shalleck.com



OAKLAND HOUSING AUTHORITY - COMMISSIONER ROOM AV

2648 E. 14TH STREET,
 SUITE #801
 OAKLAND, CA 94601

PROJECT # XX-XXX

MARK	DATE	DESCRIPTION
	12/10/20	100% DD
	01/08/21	95% CD
	02/03/21	100% CD

DRAWING TITLE
AV WIRE & CONDUIT RISER

ISSUE DATE 02-03-2021	DRAWING NO. AV501
DRAWN BY GTEH	CHECKED BY IdH

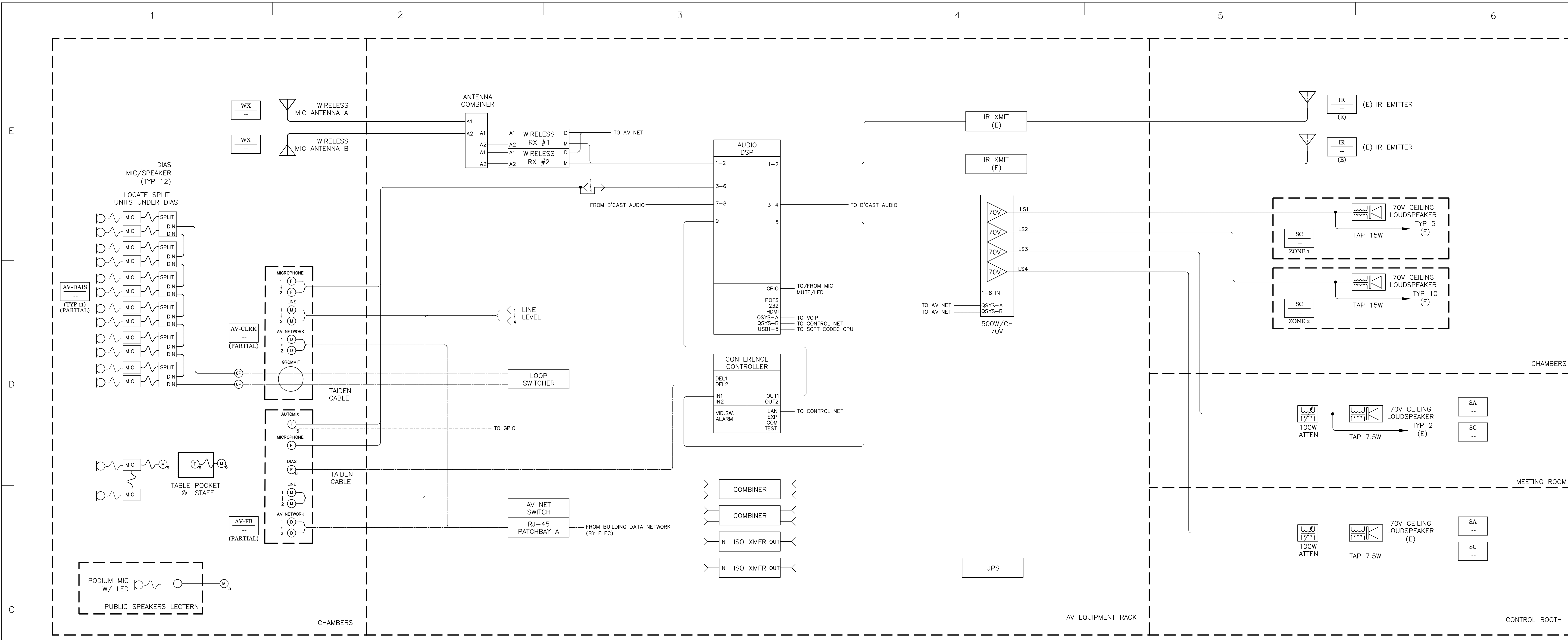

1 AUDIO BLOCK DIAGRAM
NTS

The Shalleck Collaborative Inc.
Planning and Design of Theatres
Production Systems | AV
1553 Martin Luther King Jr Way
Berkeley, CA 94709
415-956-4100 www.shalleck.com



OAKLAND HOUSING AUTHORITY - COMMISSIONER ROOM AV

2648 E. 14TH STREET,
SUITE #801
OAKLAND, CA 94601

PROJECT # xx-xxx

MARK	DATE	DESCRIPTION
	12/10/20	100% DD
	01/08/21	95% CD
	02/03/21	100% CD

DRAWING TITLE
AV BLOCK DIAGRAMS

ISSUE DATE 02-03-2021	DRAWING NO.
DRAWN BY GTEH	AV510
CHECKED BY IdH	

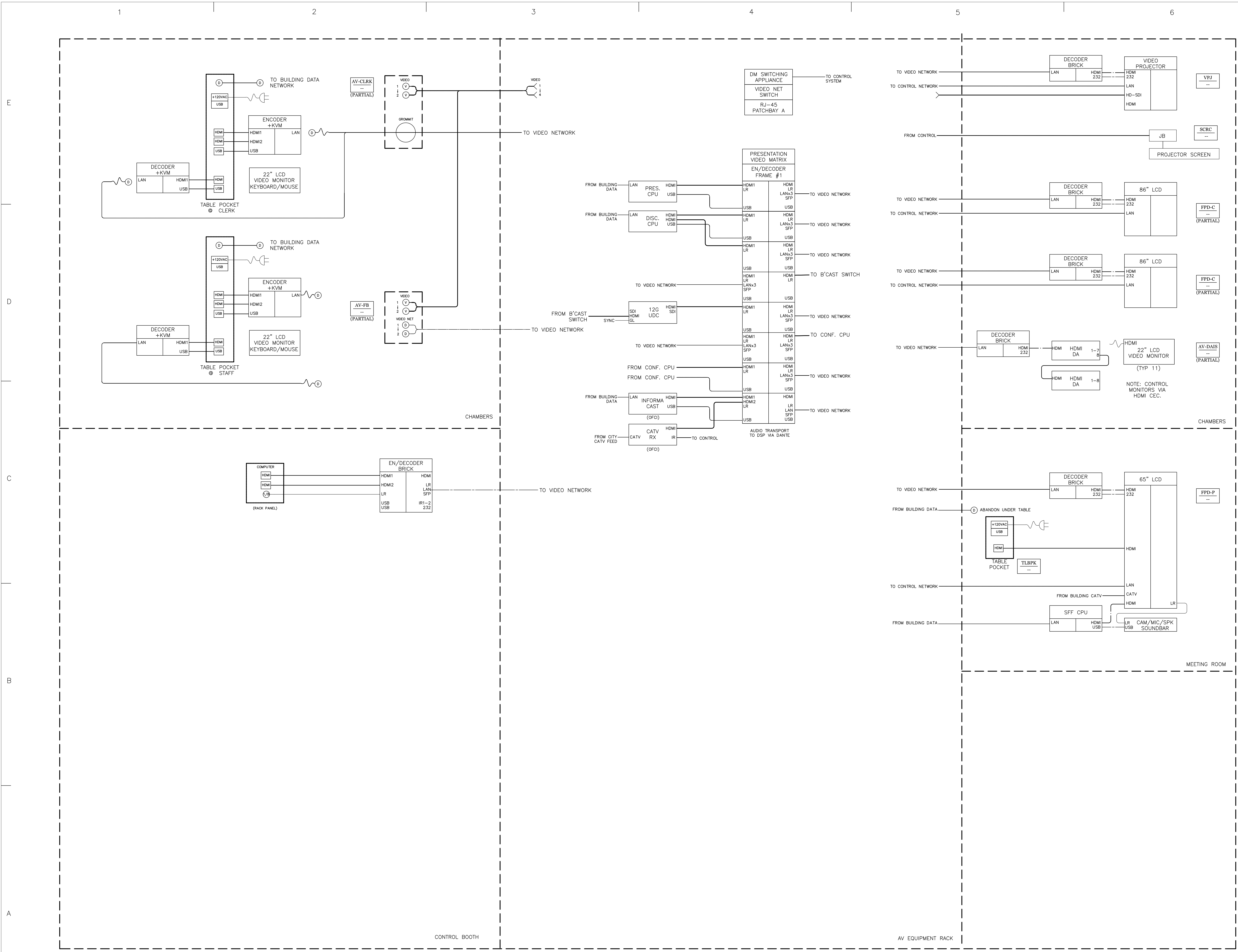

1 VIDEO BLOCK DIAGRAM

The Shalleck Collaborative Inc.
 Planning and Design of Theatres
 Production Systems | AV
 1553 Martin Luther King Jr Way
 Berkeley, CA 94709
 415-956-4100 www.shalleck.com



OAKLAND HOUSING AUTHORITY - COMMISSIONER ROOM AV

2648 E. 14TH STREET,
 SUITE #801
 OAKLAND, CA 94601

PROJECT # XX-XXX

MARK	DATE	DESCRIPTION
	12/10/20	100% DD
	01/08/21	95% CD
	02/03/21	100% CD

DRAWING TITLE
AV BLOCK DIAGRAMS

ISSUE DATE: 02-03-2021
 DRAWN BY: GTEH
 CHECKED BY: IdH
 DRAWING NO.: AV511

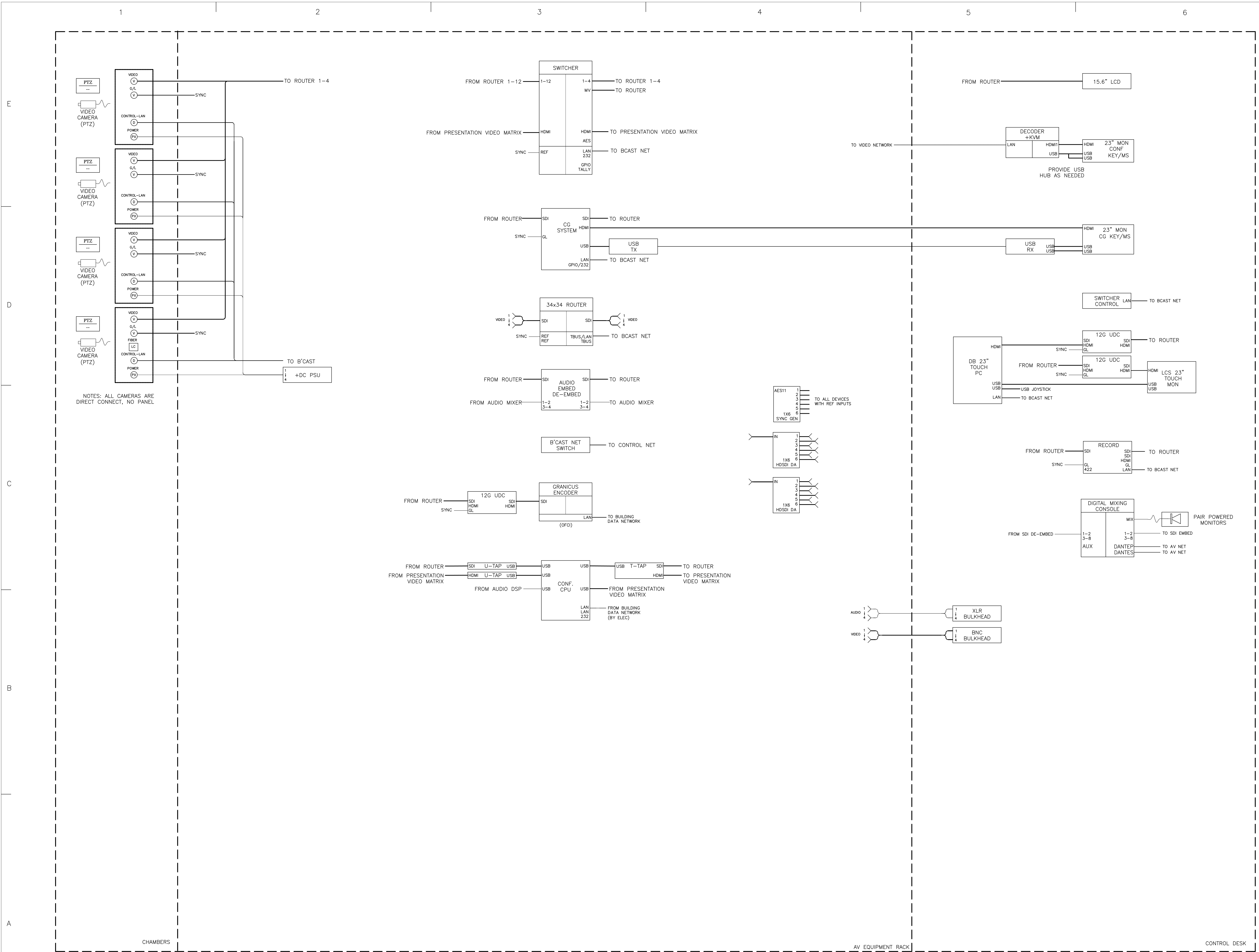

The Shalleck Collaborative Inc.
 Planning and Design of Theatres
 Production Systems | AV
 1553 Martin Luther King Jr Way
 Berkeley, CA 94709
 415-956-4100 www.shalleck.com



OAKLAND HOUSING AUTHORITY - COMMISSIONER ROOM AV
 2648 E. 14TH STREET,
 SUITE #801
 OAKLAND, CA 94601

PROJECT # XX-XXX

MARK	DATE	DESCRIPTION
	12/10/20	100% DD
	01/08/21	95% CD
	02/03/21	100% CD

DRAWING TITLE
AV BLOCK DIAGRAMS

ISSUE DATE 02-03-2021	DRAWING NO. AV512
DRAWN BY GTEH	CHECKED BY IdH

1 BROADCAST BLOCK DIAGRAM

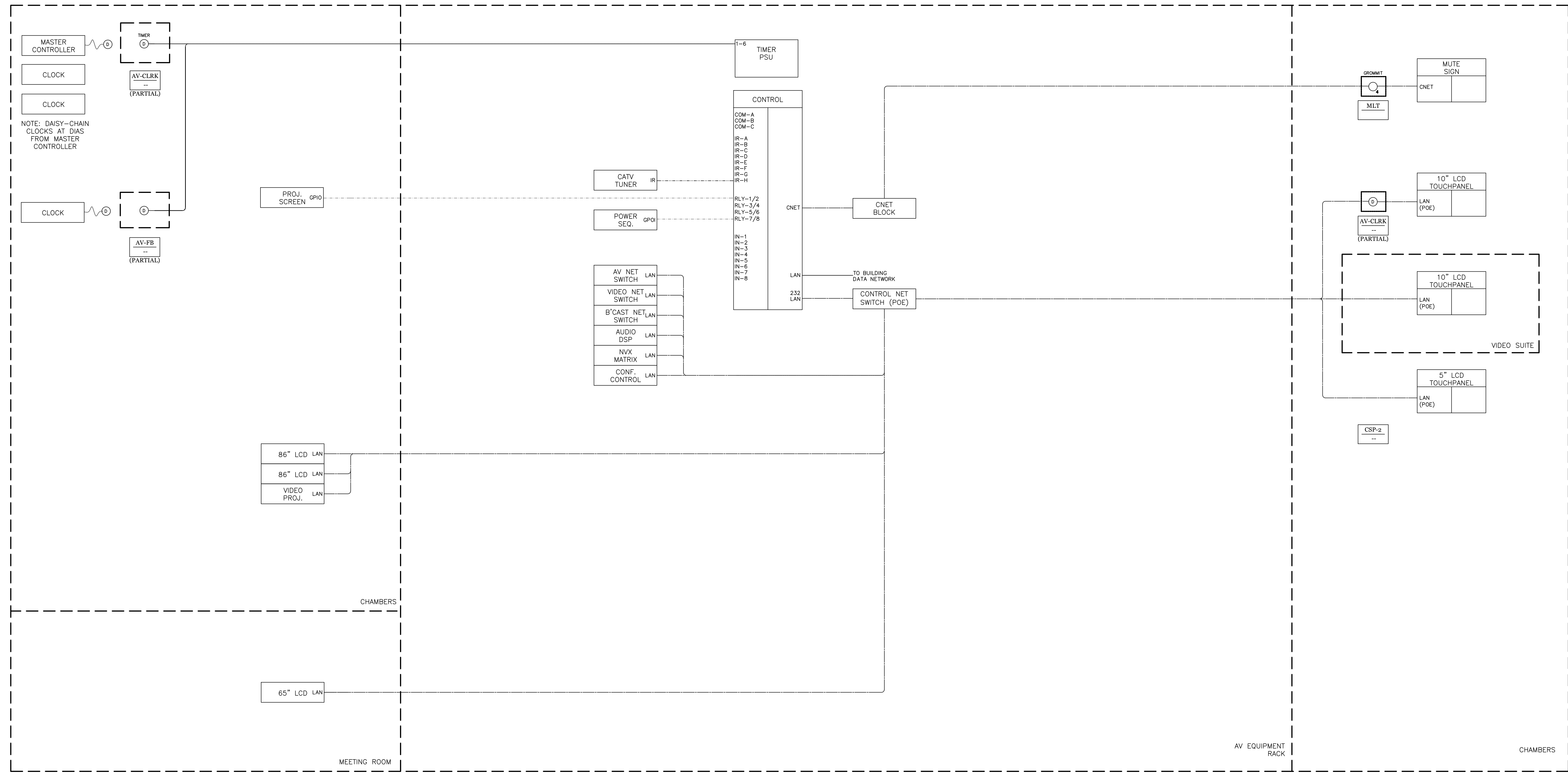

1 CONTROL BLOCK DIAGRAM
NTS

The Shalleck Collaborative Inc.
 Planning and Design of Theatres
 Production Systems | AV
 1553 Martin Luther King Jr Way
 Berkeley, CA 94709
 415-956-4100 www.shalleck.com



OAKLAND HOUSING AUTHORITY - COMMISSIONER ROOM AV

2648 E. 14TH STREET,
 SUITE #801
 OAKLAND, CA 94601

PROJECT # XX-XXX

MARK	DATE	DESCRIPTION
	12/10/20	100% DD
	01/08/21	95% CD
	02/03/21	100% CD

DRAWING TITLE
AV BLOCK DIAGRAMS

ISSUE DATE 02-03-2021	DRAWING NO.
DRAWN BY GTEH	AV513
CHECKED BY IdH	

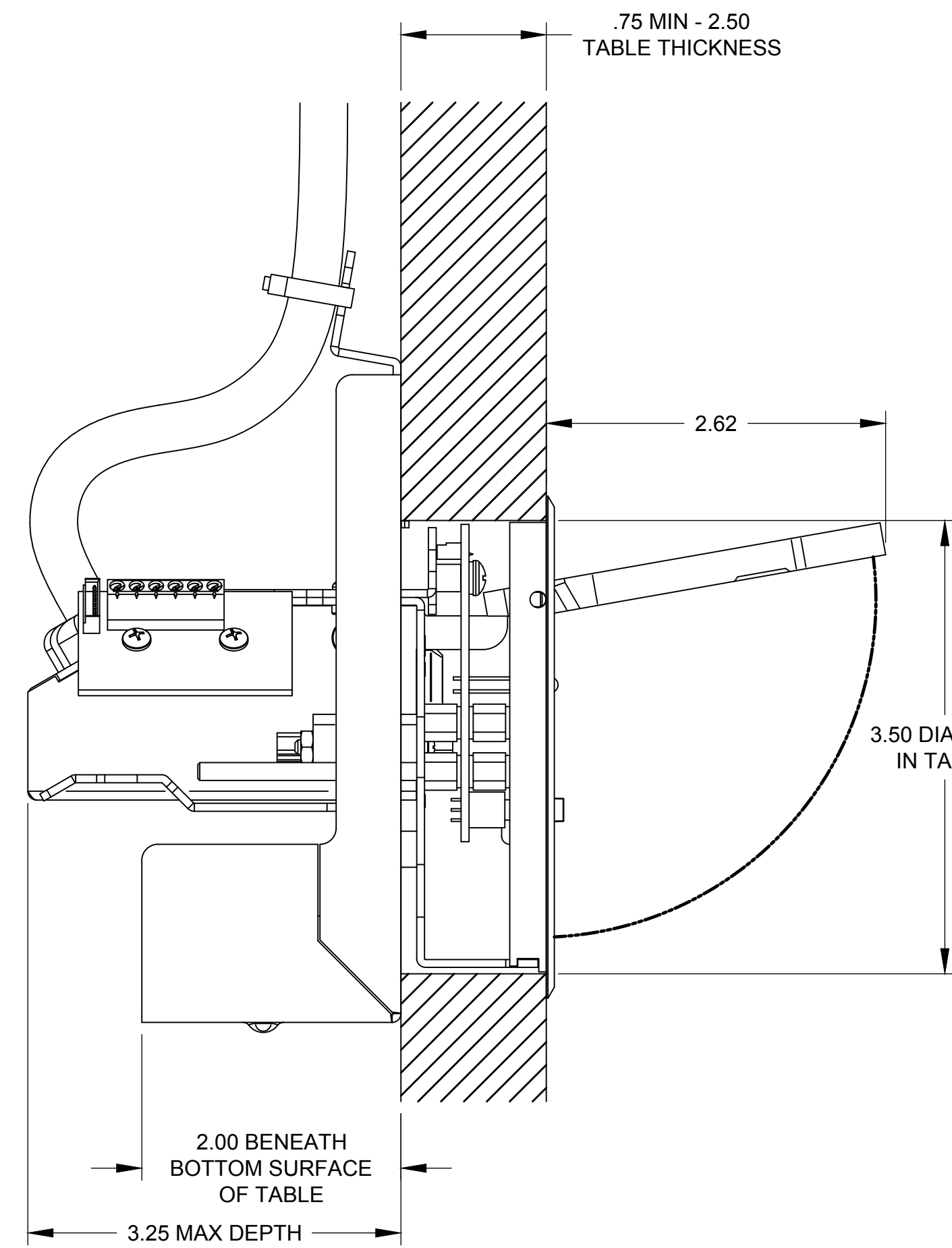

1 AV DEVICE TLBPK
12"=1'-0"

THIS DEVICE WEIGHS LESS THAN 20 LBS.

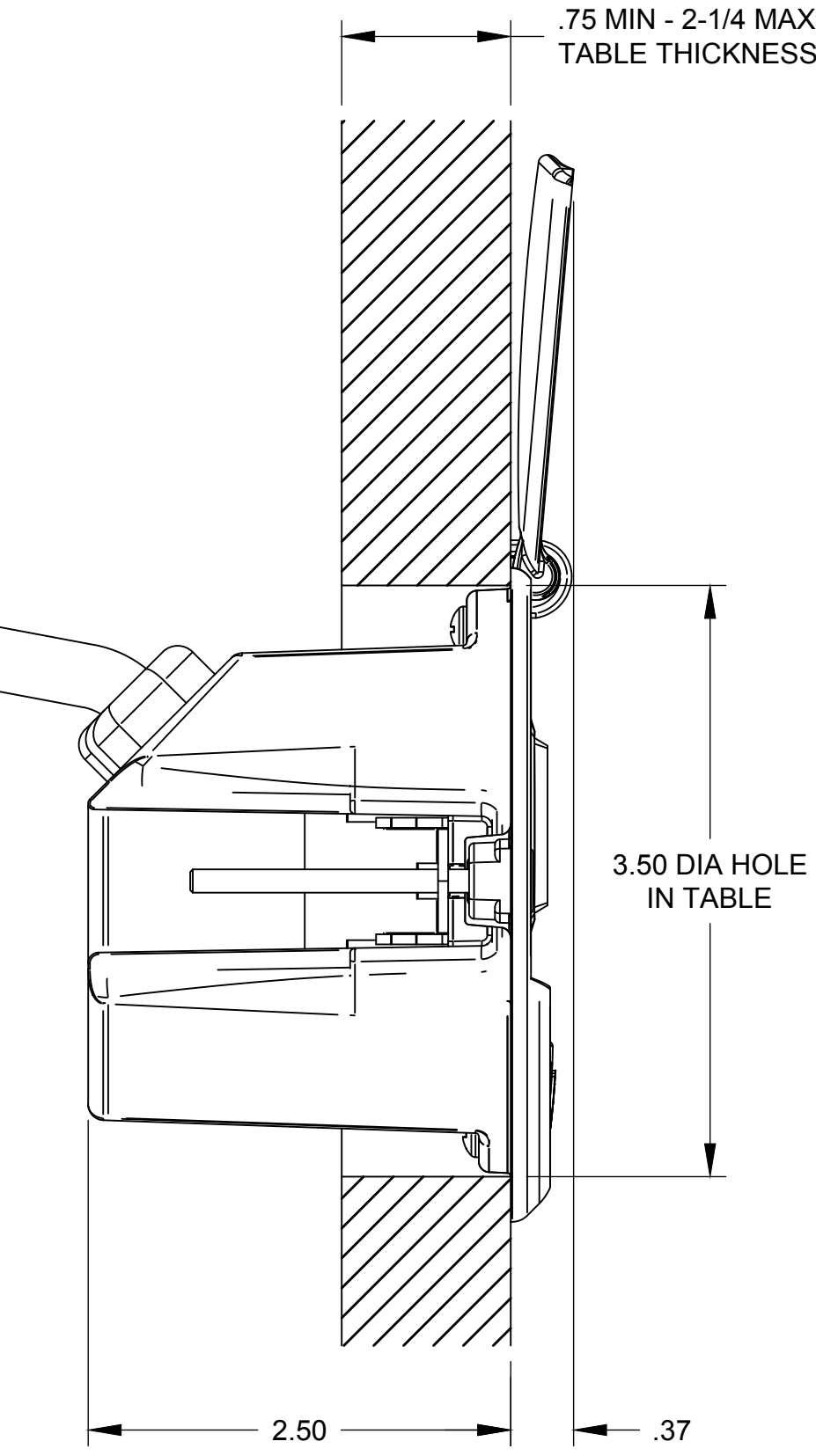
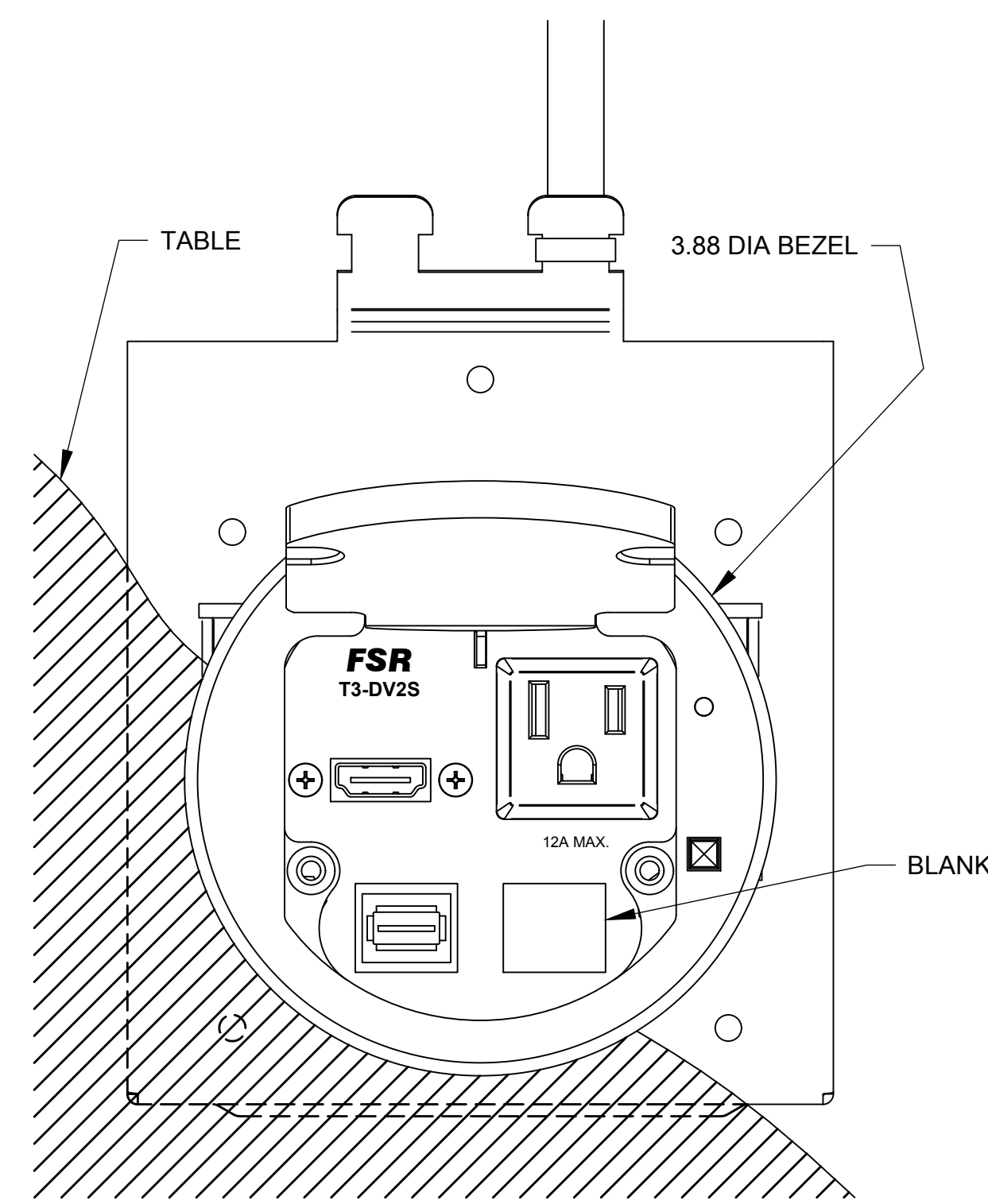

2 AV DIAS CHARGING TABLE POCKET
12"=1'-0"

THIS DEVICE WEIGHS LESS THAN 20 LBS.

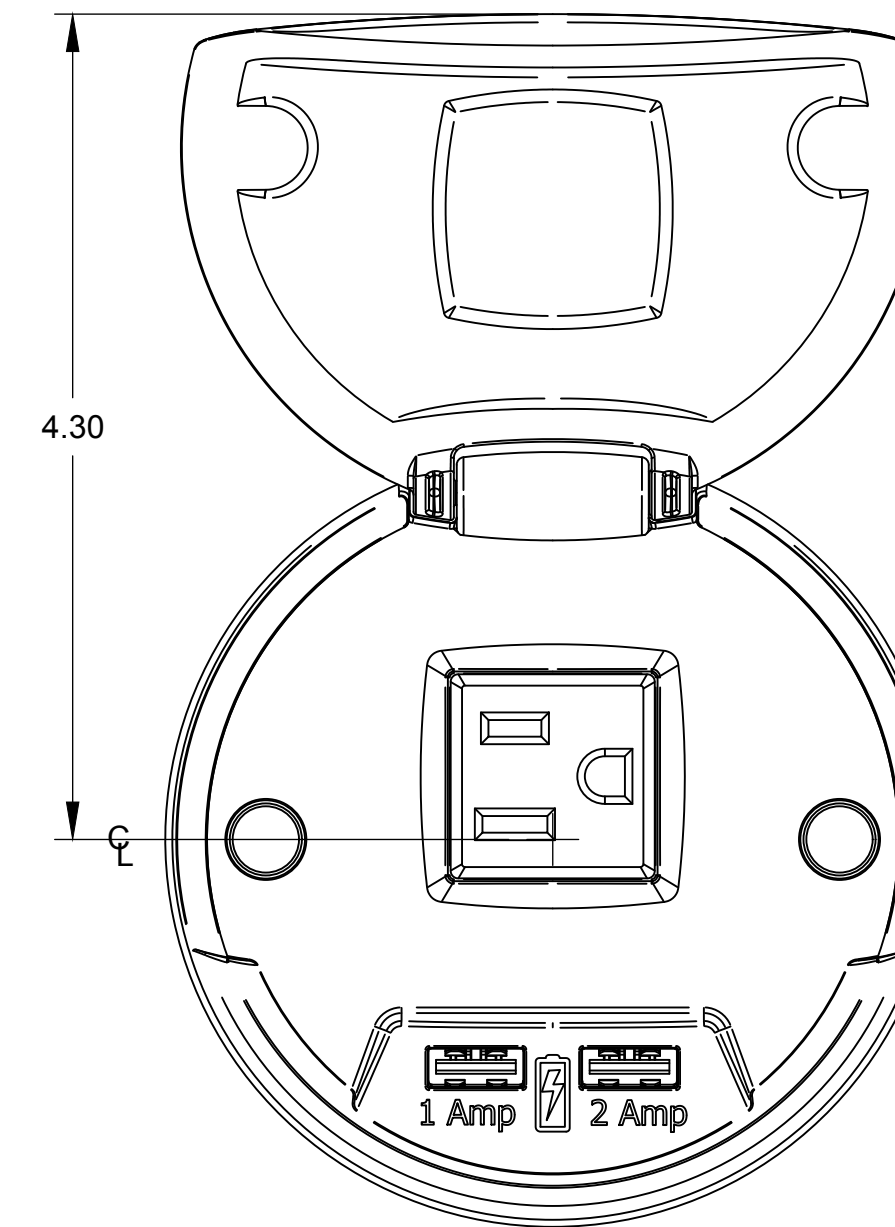

3 NOT USED
NTS

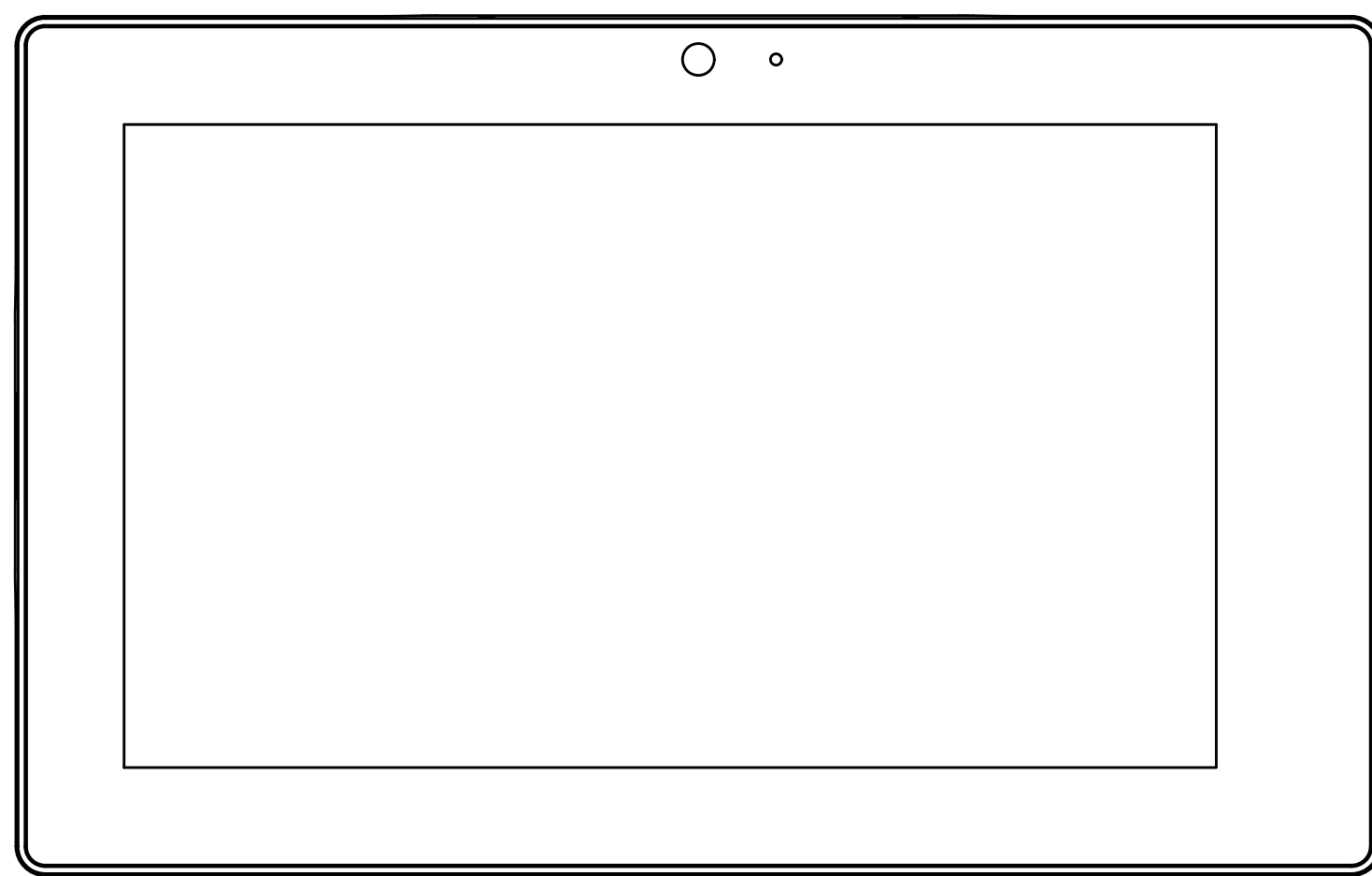

4 AV DEVICE CSP-2
12"=1'-0"

THIS DEVICE WEIGHS LESS THAN 20 LBS.

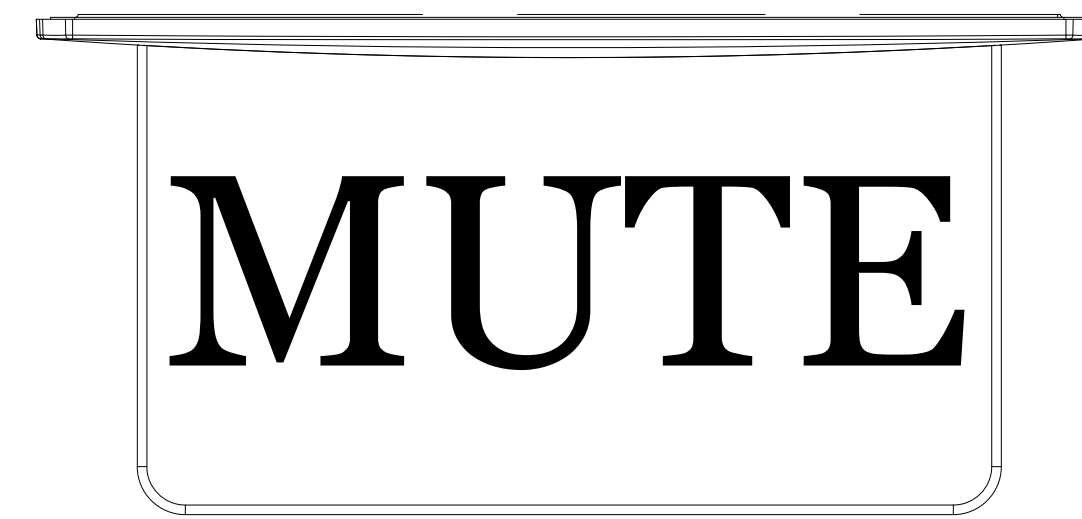

5 AV DEVICE MLT
6"=1'-0"

THIS DEVICE WEIGHS LESS THAN 20 LBS.

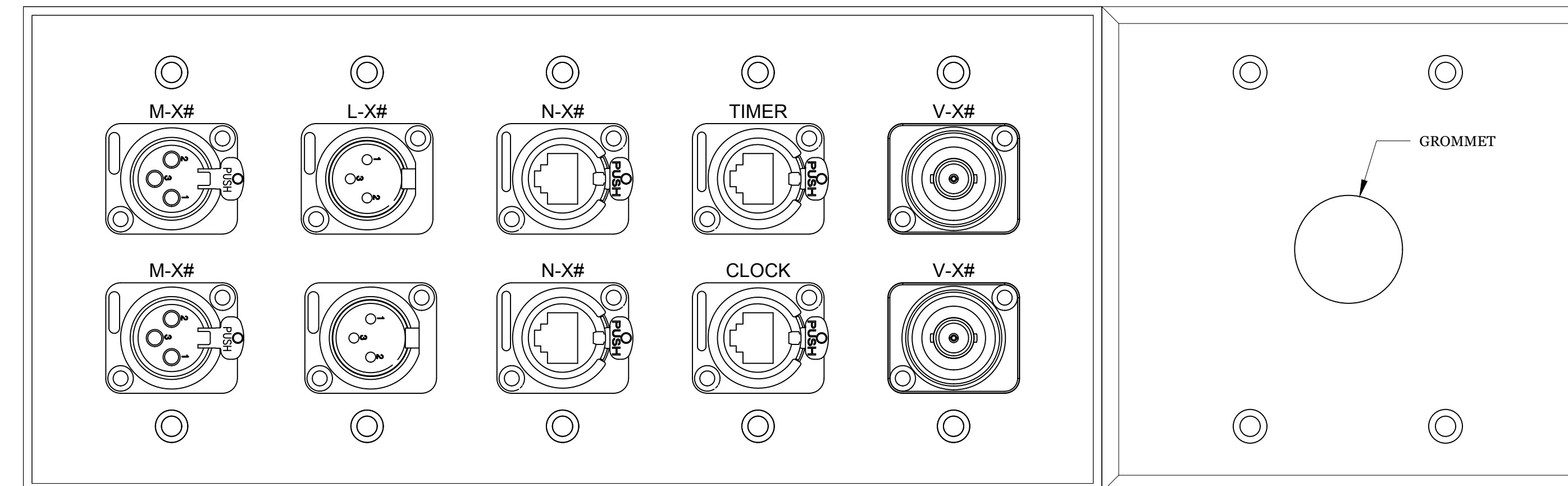

6 AV DEVICE AV-CLRK
12"=1'-0"

THIS DEVICE WEIGHS LESS THAN 20 LBS.

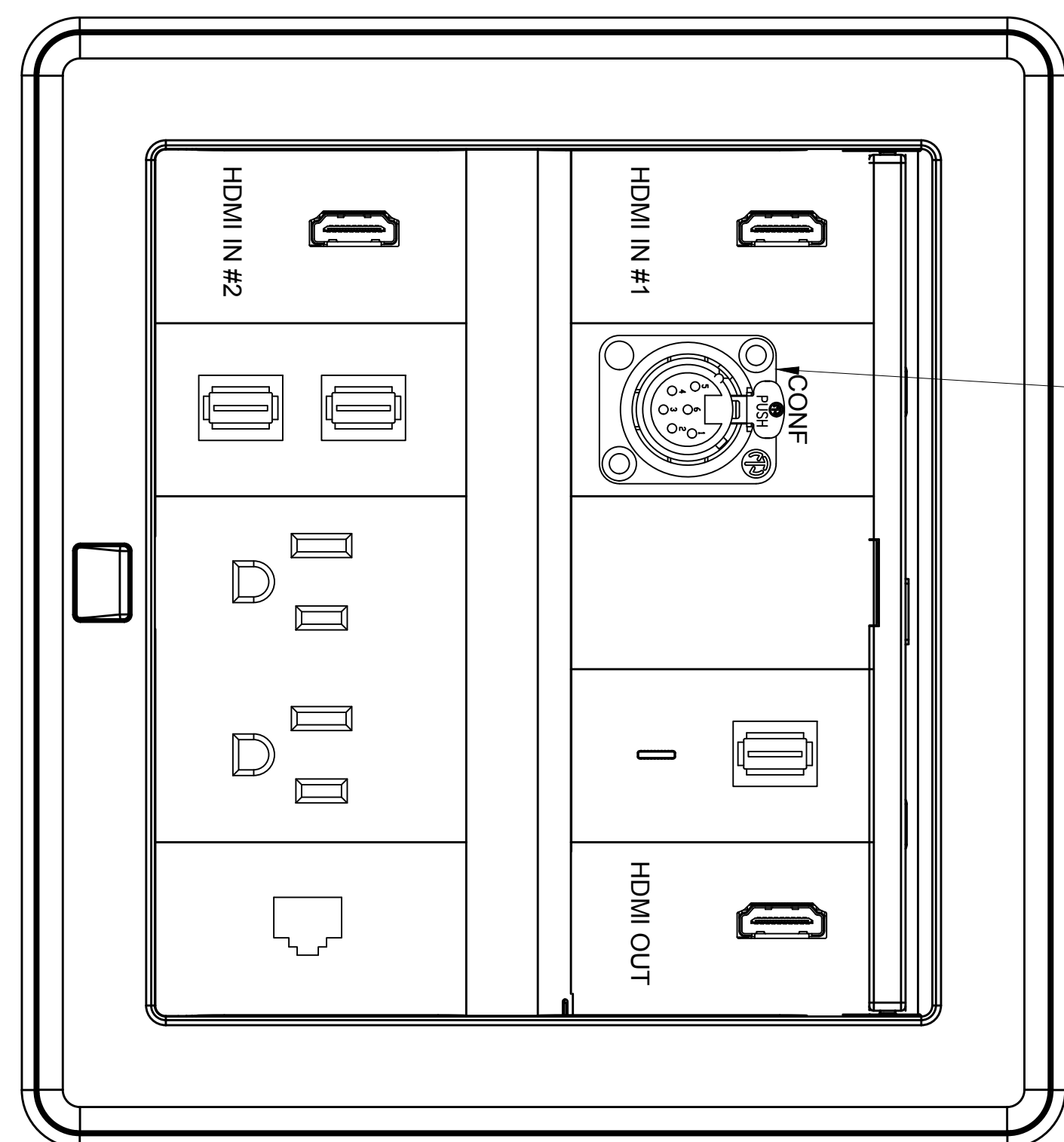

7 AV DAIS STAFF AND CLERK TABLE POCKETS
12"=1'-0"

THIS DEVICE WEIGHS LESS THAN 20 LBS.

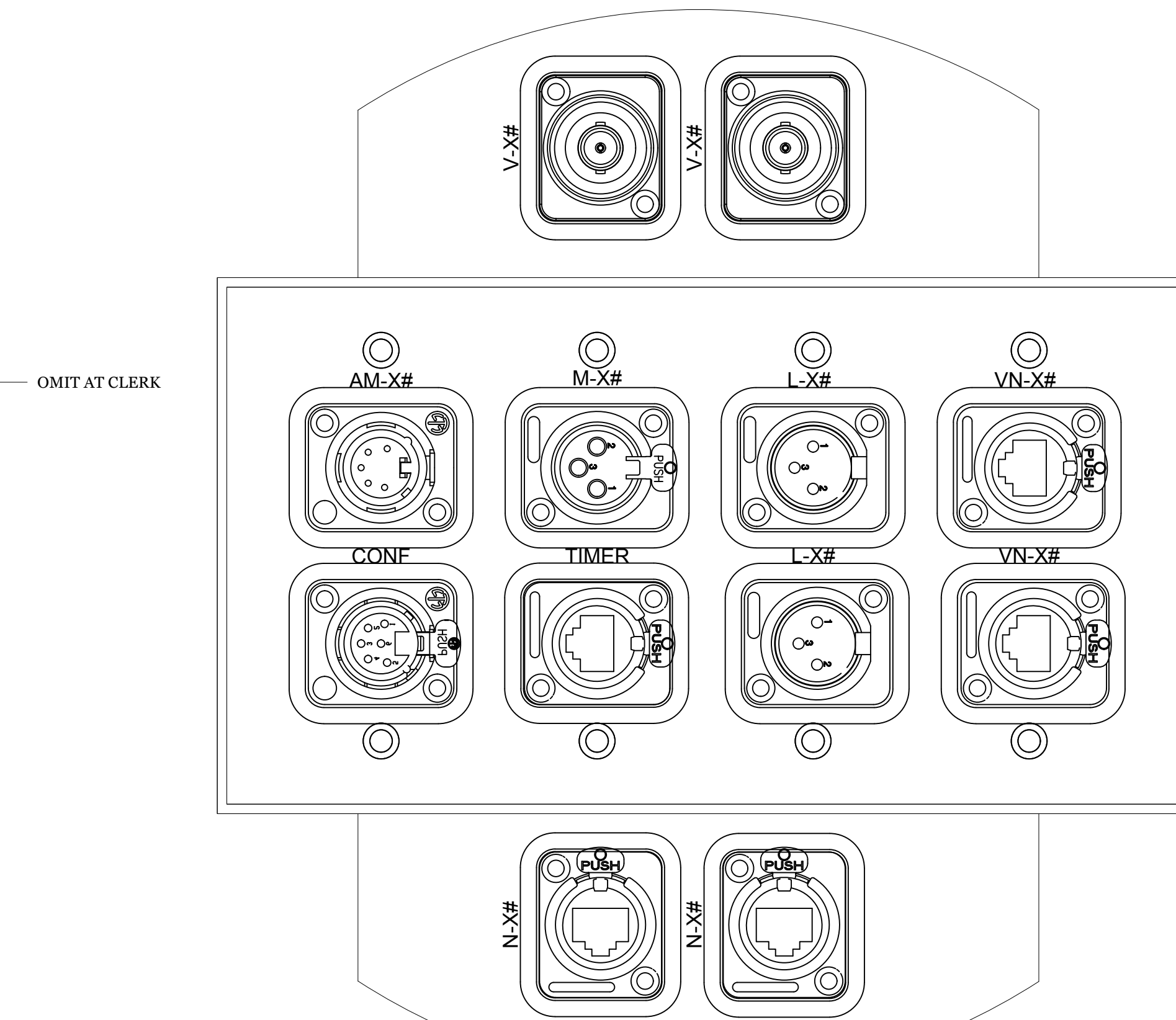

8 AV DEVICE AV-FB
12"=1'-0"

THIS DEVICE WEIGHS LESS THAN 20 LBS.

GENERAL NOTES

1. ALL AC OUTLETS, CONDUIT & BACKBOXES BY ELECTRICAL. REQUIRED STRUCTURAL BACKING BY STRUCTURAL ENGINEER.
2. A/V CONTRACTOR TO COORDINATE WITH ELECTRICAL TO DETERMINE EXACT LOCATION OF A/V BACKBOXES.
3. ALL VISIBLE LOUDSPEAKERS & PANELS SHALL BE PROVIDED IN A COLOR AS DETERMINED BY THE ARCHITECT DURING THE SHOP DRAWING PHASE. COORDINATE EXACT MOUNTING CONDITIONS WITH ARCHITECT, STRUCTURAL ENGINEER & GENERAL CONTRACTOR.

The Shalleck Collaborative Inc.
Planning and Design of Theatres
Production Systems | AV
1553 Martin Luther King Jr Way
Berkeley, CA 94709
415-956-4100 www.shalleck.com

Oakland Housing Authority

OAKLAND HOUSING AUTHORITY - COMMISSIONER ROOM AV

2648 E. 14TH STREET,
SUITE #801
OAKLAND, CA 94601

PROJECT # XX-XXX

MARK	DATE	DESCRIPTION
	12/10/20	100% DD
	01/08/21	95% CD
	02/03/21	100% CD

DRAWING TITLE
AV PANEL ELEVATIONS

ISSUE DATE
02-03-2021
DRAWN BY
GTEH
CHECKED BY
IdH

DRAWING NO.
AV701

PULL-OUT AV RACKS					
LOCATION	MODEL	A OVERALL HEIGHT	B OVERALL WIDTH	C OVERALL DEPTH	D FRAME ROLL OUT
CONTROL BOOTH	MRK-4431AXS-26	83.125"	22.00"	31.4"	47.5" TO 48.5"

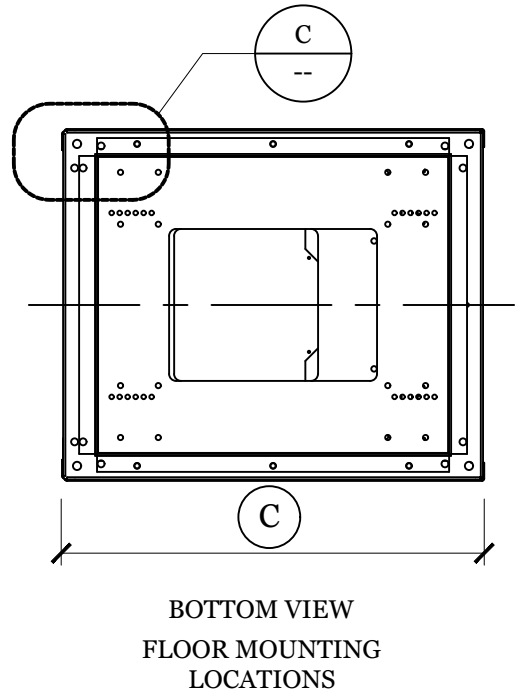
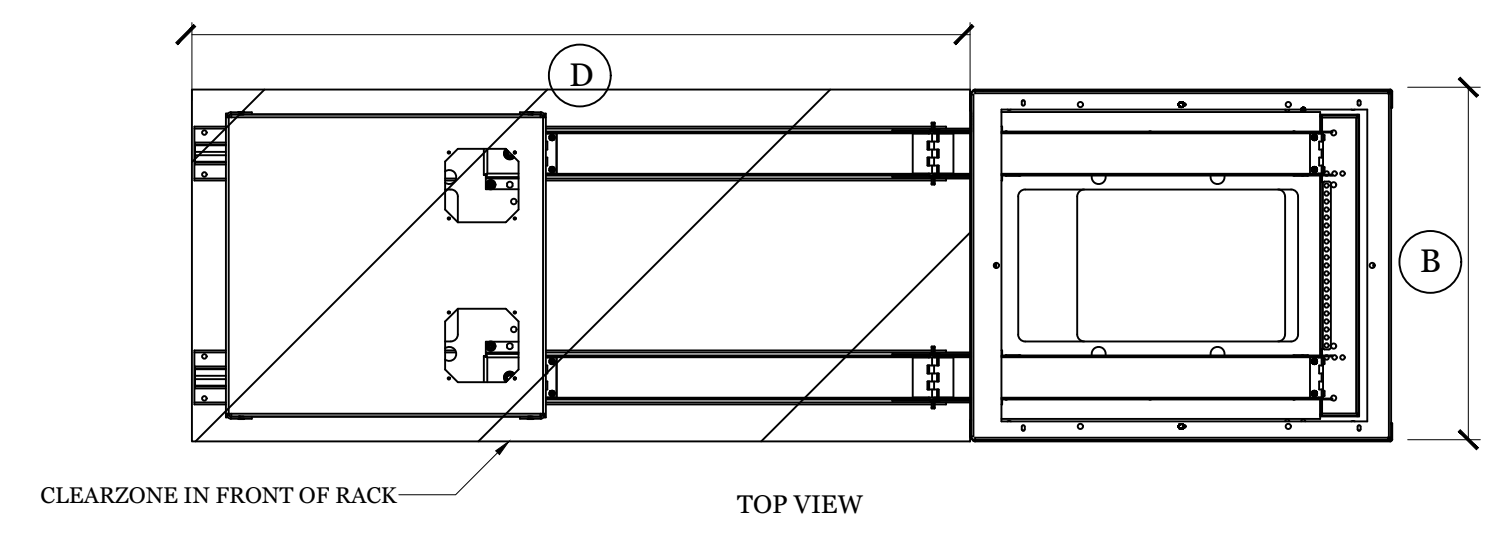

WHEN MOUNTED AS SHOWN WITH AN ENGINEERED ANCHORAGE, THE BASE ANCHORAGE IS DESIGNED TO COMPLY WITH CBC'S SEISMIC REQUIREMENTS OR SEISMIC DESIGN CATEGORY (SDC) 'D'. REFER TO RACK MFG FOR RACK CERTIFICATION.

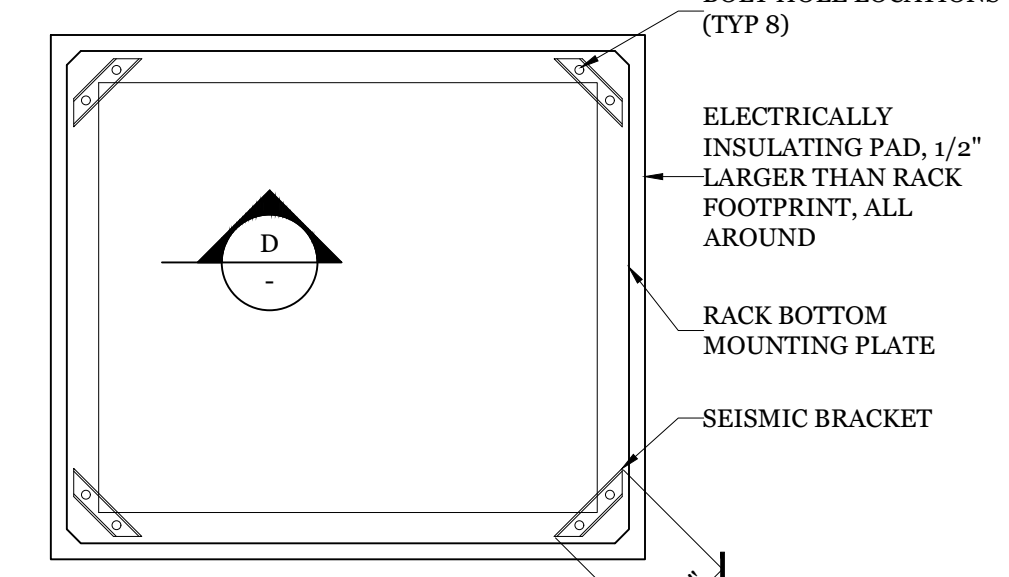

WHEN MOUNTED AS SHOWN WITH AN ENGINEERED ANCHORAGE, THE BASE ANCHORAGE IS DESIGNED TO COMPLY WITH CBC'S SEISMIC REQUIREMENTS IN ZONE 4 OR SEISMIC DESIGN CATEGORY (SDC) 'D'. REFER TO RACK MFG FOR RACK CERTIFICATION.

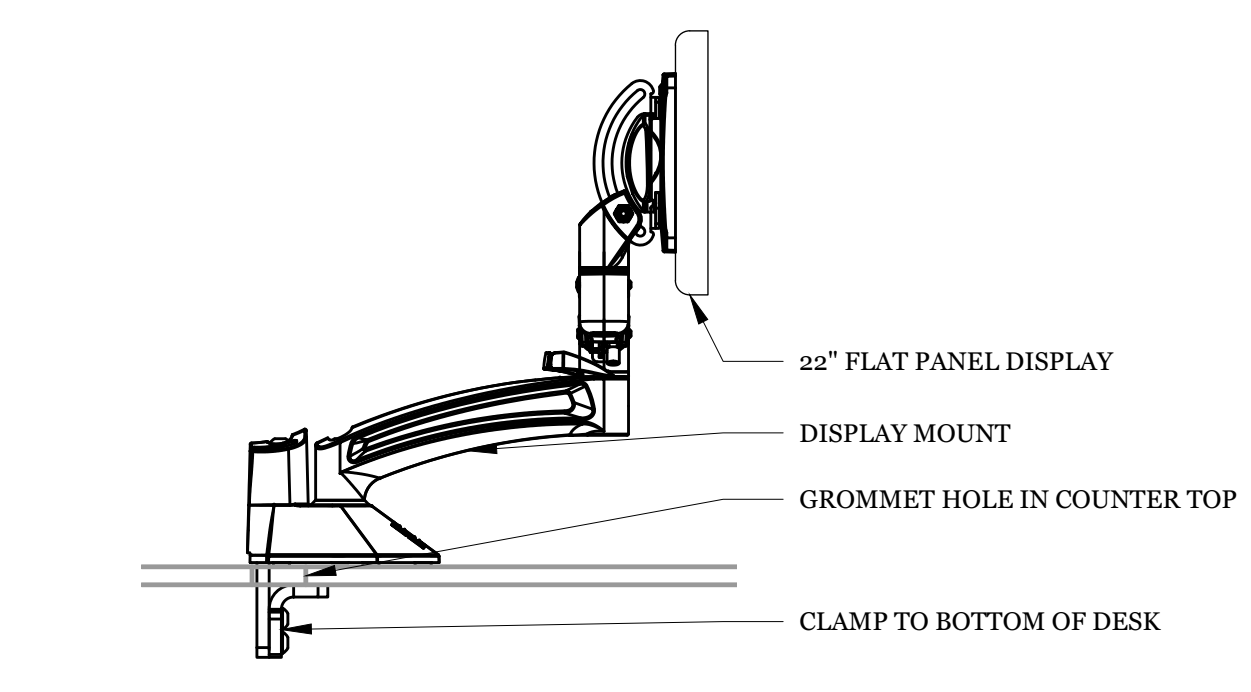
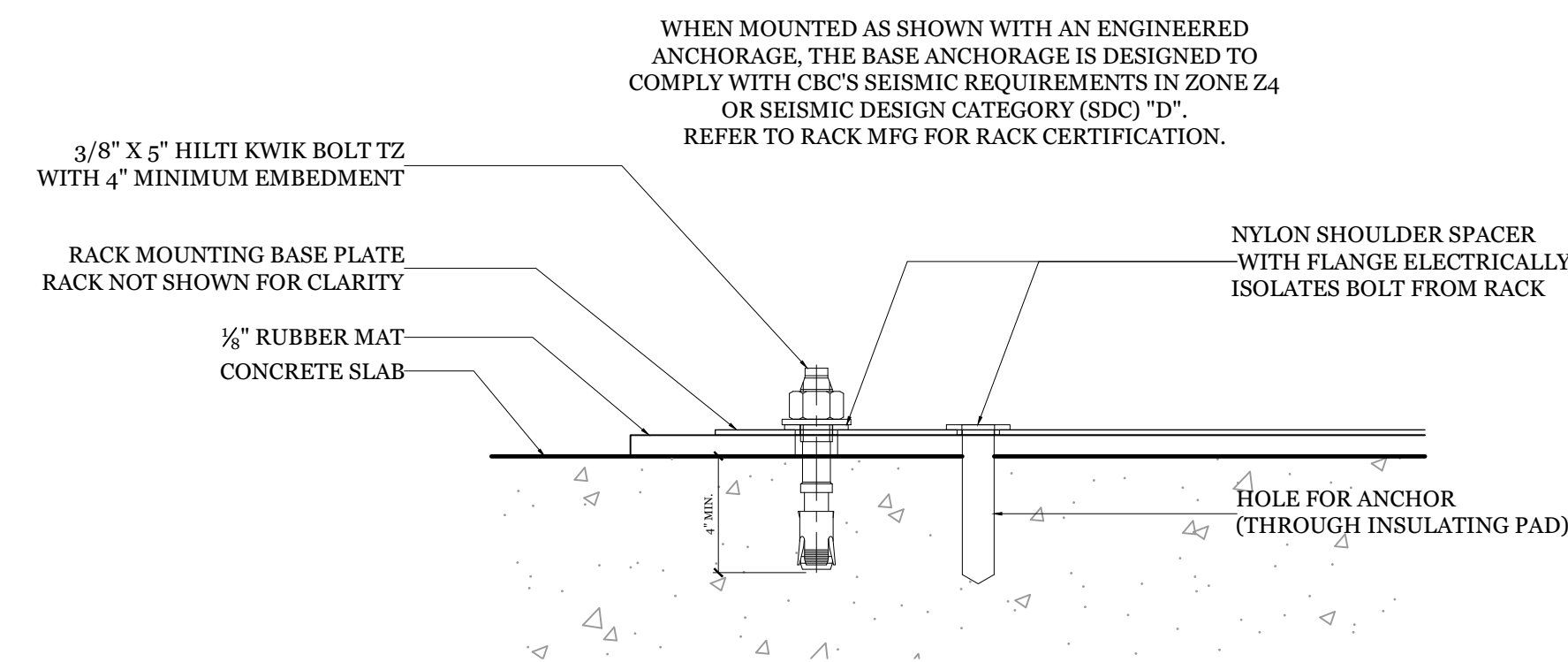

THIS DEVICE WEIGHS LESS THAN 20 LBS.

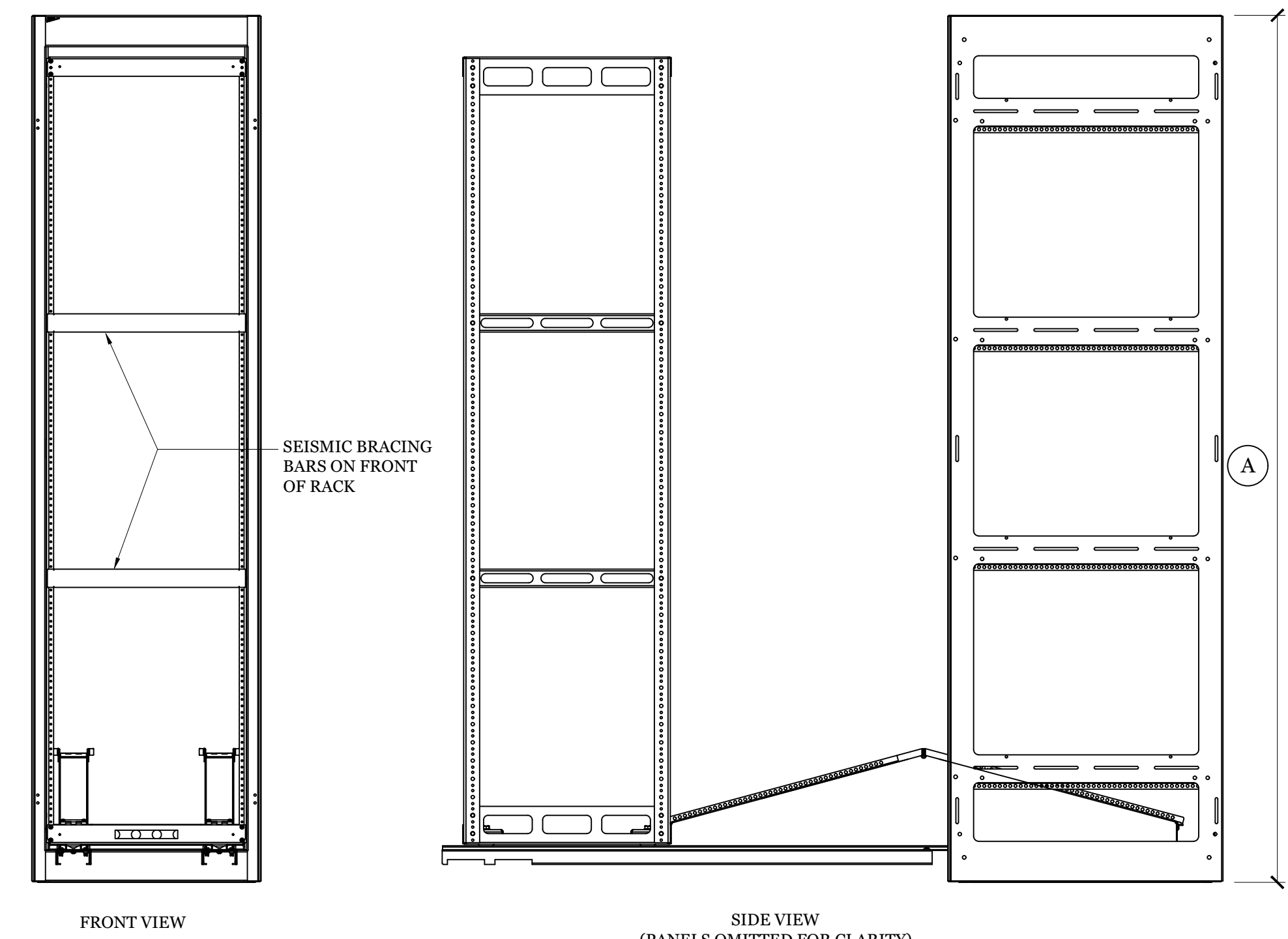
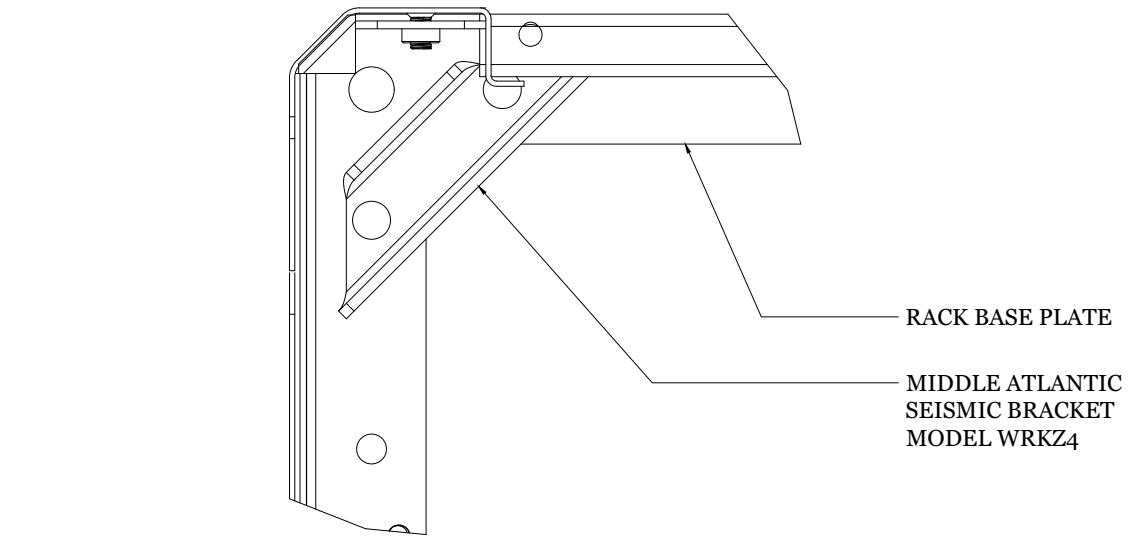
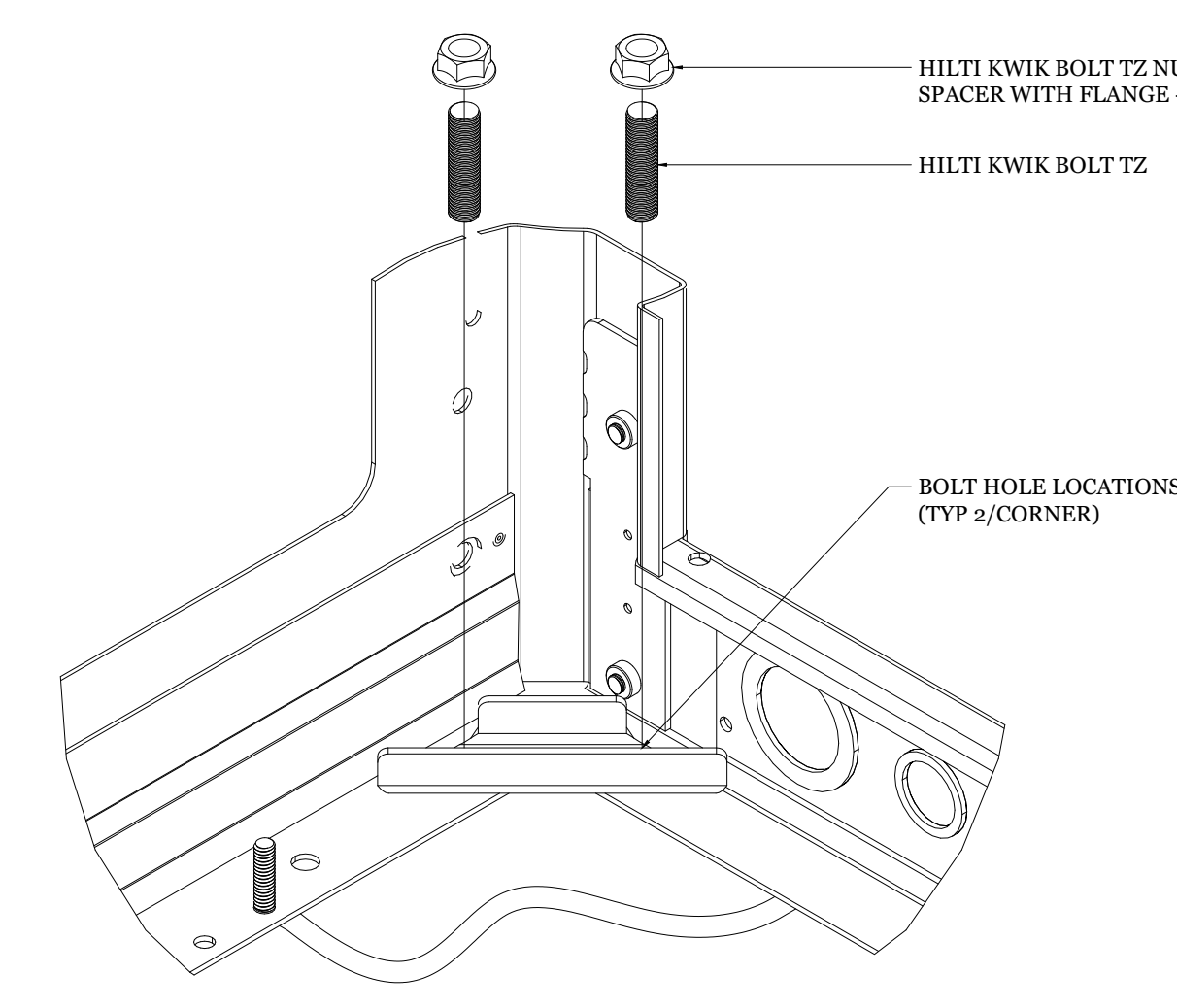

1 MRK W/ AXS EQUIPMENT RACK MOUNTING
1"=1'-0"

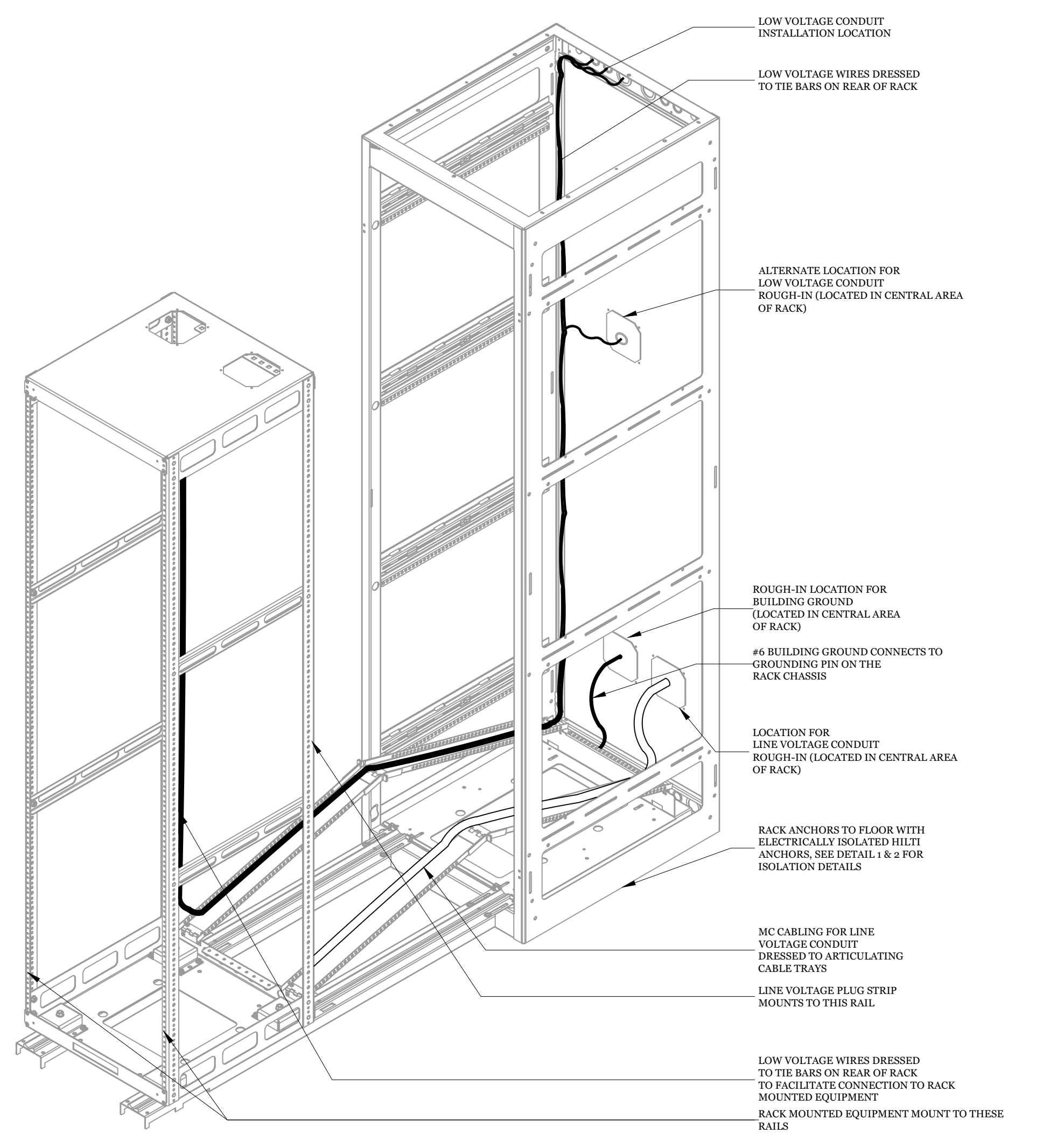

EMPTY RACK WEIGHT 200 LBS.
MAX EQUIPMENT WEIGHT 650 LBS.
MAX TOTAL WEIGHT 850 LBS.

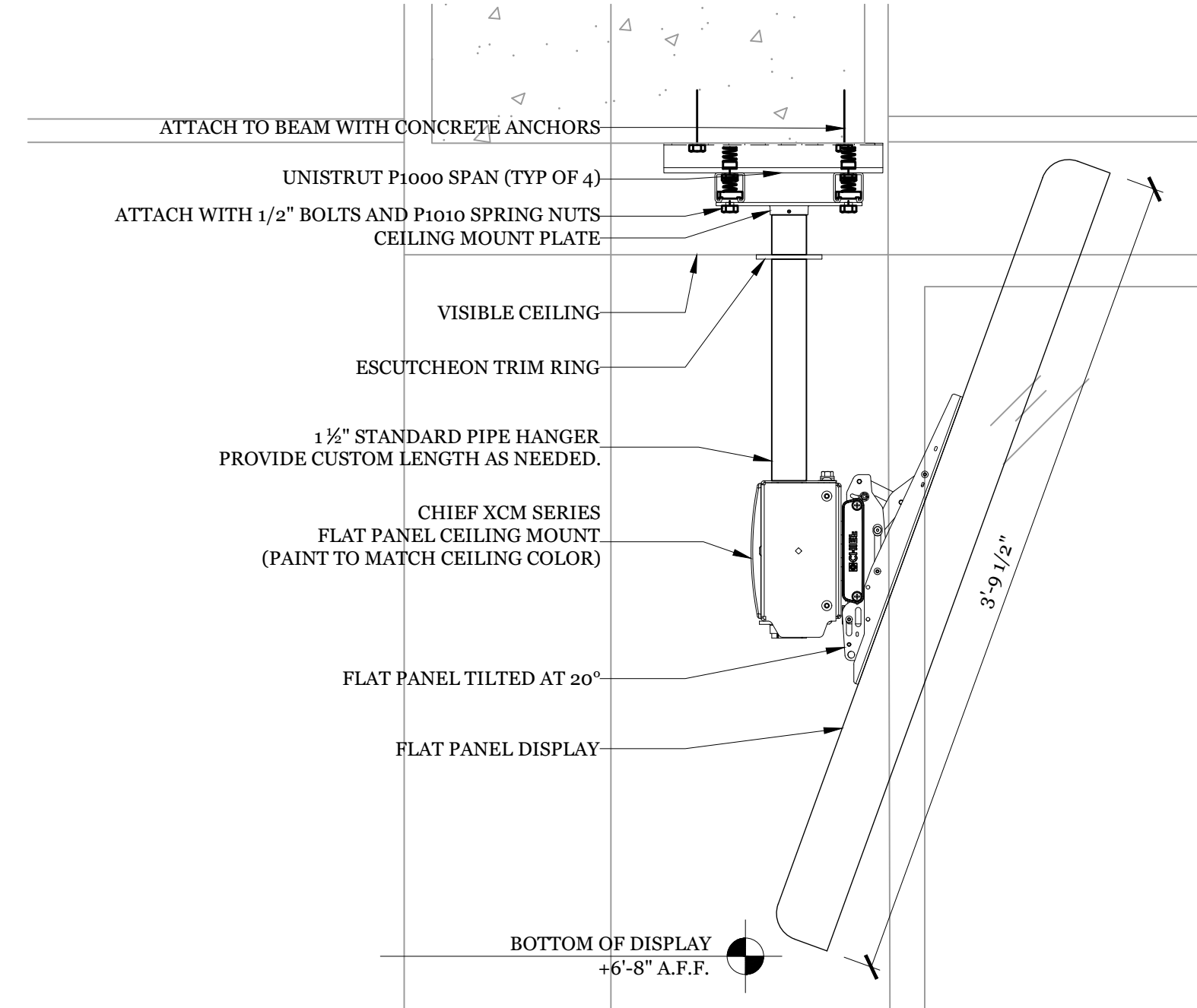

3 CEILING MOUNTED FLAT PANEL DISPLAY MOUNTING
1-1/2"=1'-0"

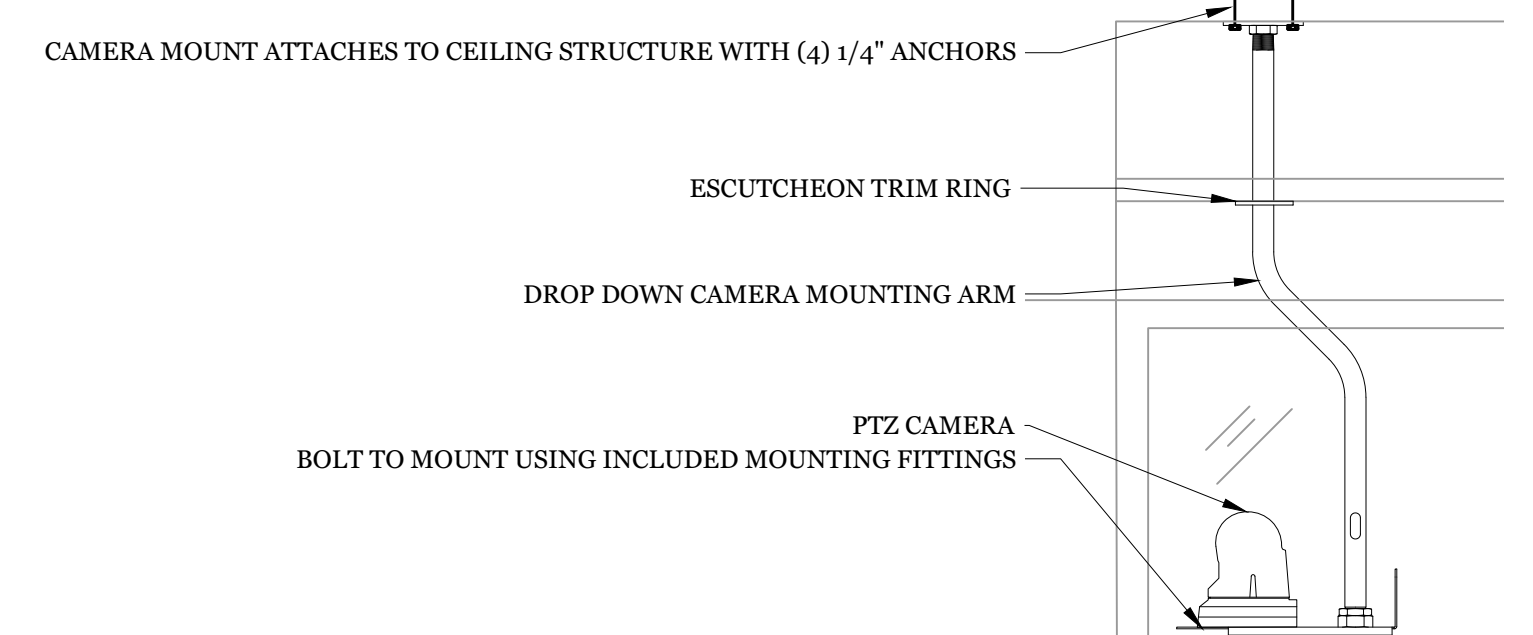

8 CEILING MOUNTED PTZ CAMERA MOUNTING
1-1/2"=1'-0"

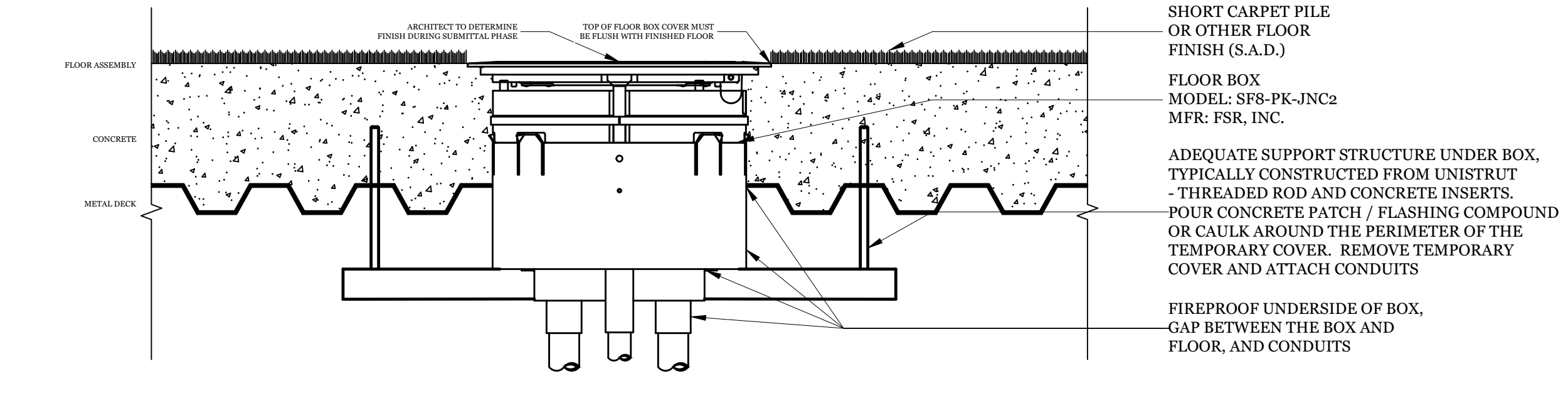

4 POKE-THROUGH FLOOR BOX MOUNTING
3"=1'-0"

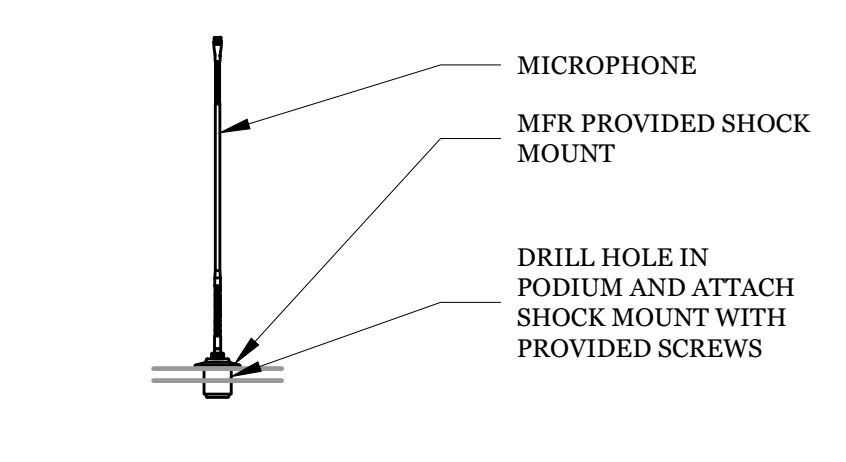

5 PODIUM MICROPHONE MOUNTING
1"=1'-0"

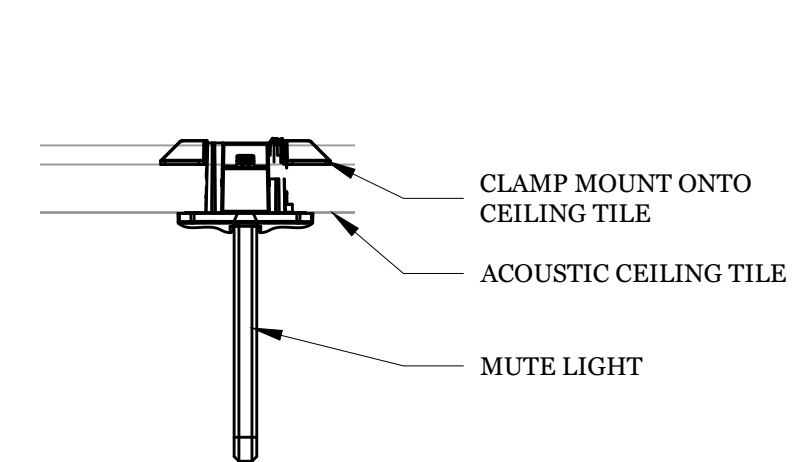

6 MUTE LIGHT MOUNTING
3"=1'-0"

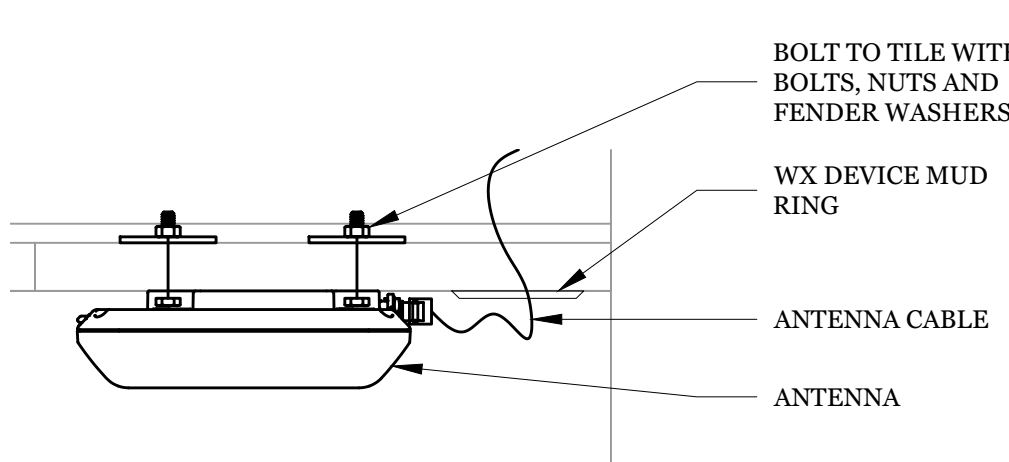

7 WX ANTENNA MOUNTING
3"=1'-0"

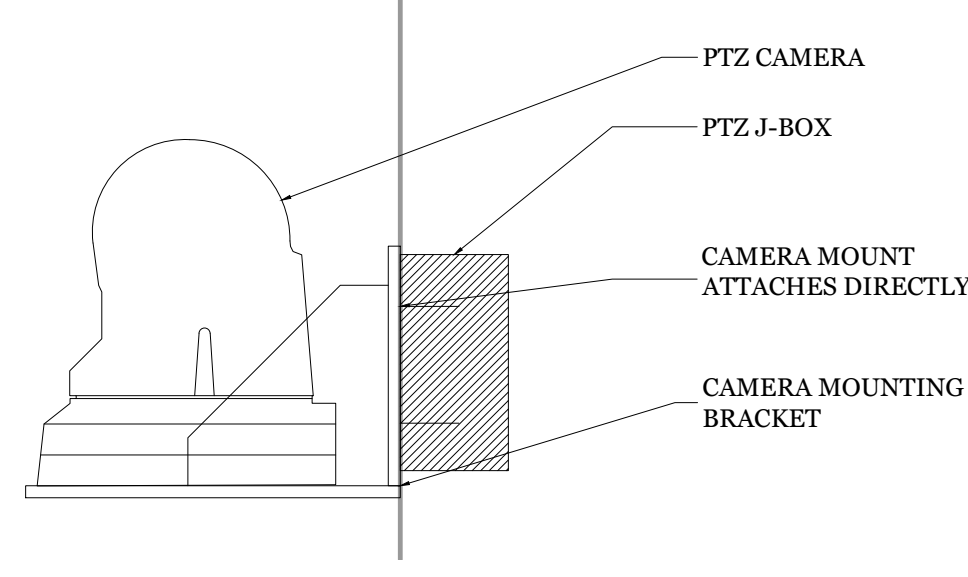

9 WALL MOUNTED PTZ CAMERA MOUNTING
3"=1'-0"

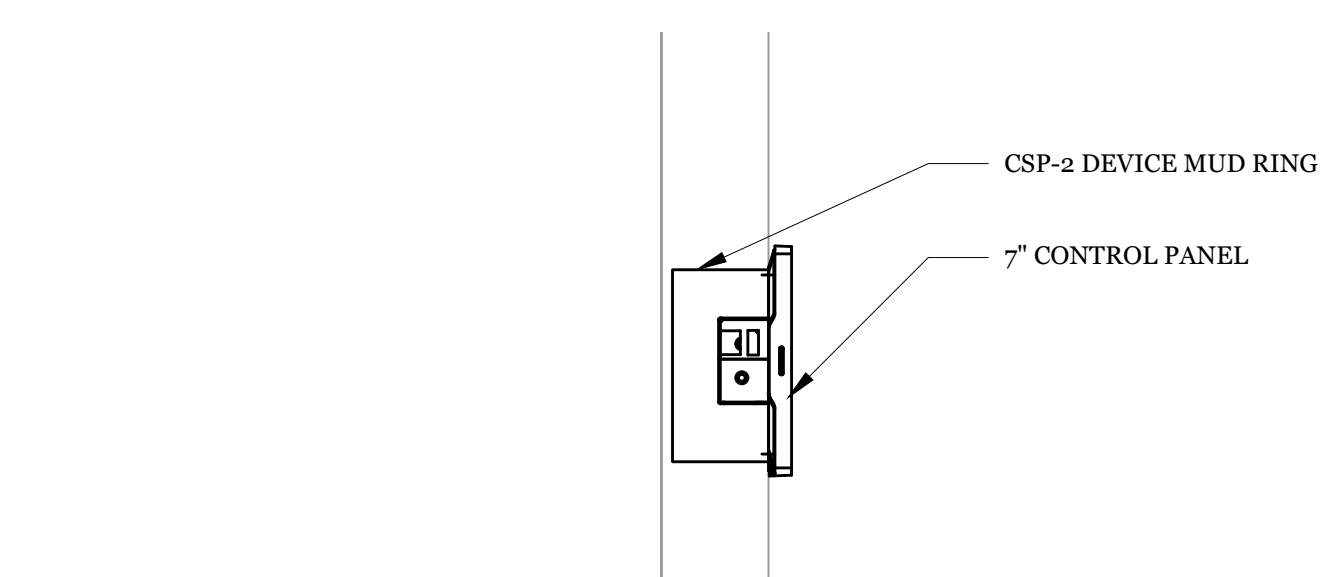

10 CSP-2 CONTROL PANEL MOUNTING
3"=1'-0"

The Shalleck Collaborative Inc.
Planning and Design of Theatres
Production Systems | AV
1553 Martin Luther King Jr Way
Berkeley, CA 94709
415-956-4100 www.shalleck.com

Oakland Housing Authority

OAKLAND HOUSING AUTHORITY - COMMISSIONER ROOM AV

2648 E. 14TH STREET, SUITE #801 OAKLAND, CA 94601

PROJECT # XX-XXX

MARK	DATE	DESCRIPTION
	12/10/20	100% DD
	01/08/21	95% CD
	02/03/21	100% CD

DRAWING TITLE
AV MOUNTING DETAILS

ISSUE DATE 02-03-2021
DRAWN BY GTEH
CHECKED BY IdH
DRAWING NO. AV710

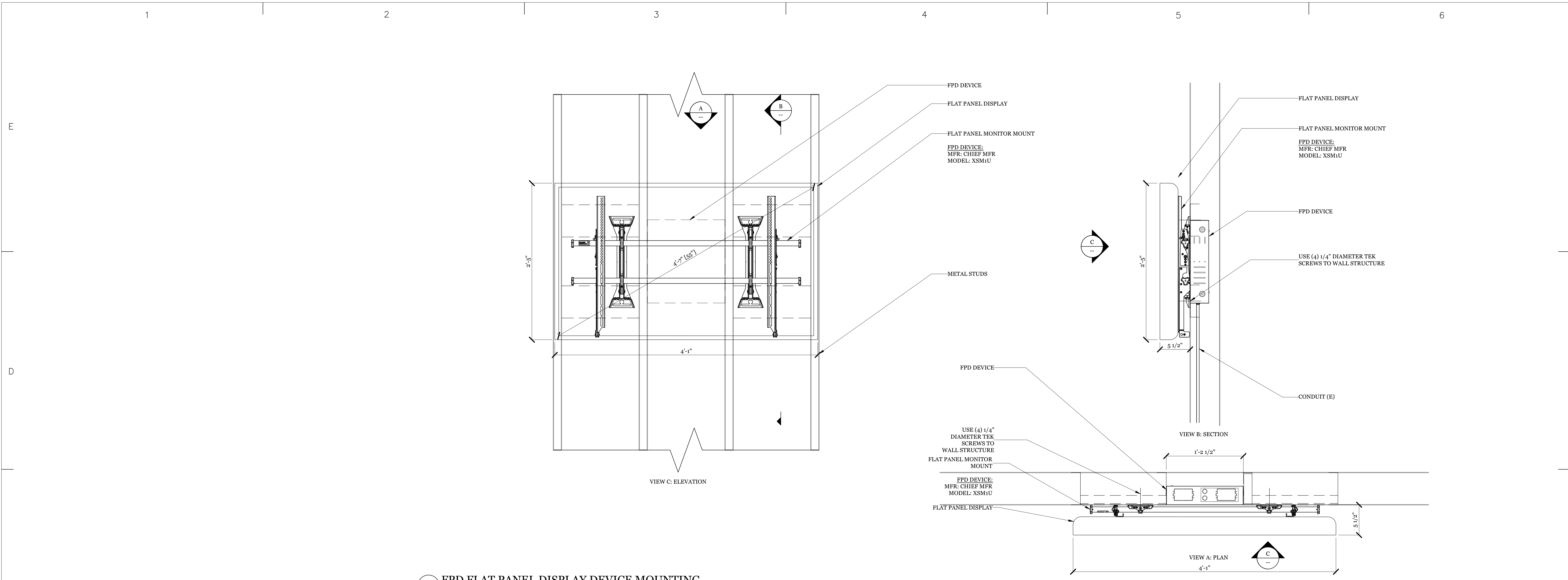

1 FPD FLAT PANEL DISPLAY DEVICE MOUNTING
1-1/2"=1'-0"

MAX TOTAL WEIGHT 250 LBS.

The Shalleck Collaborative Inc.
 Planning and Design of Theatres
 Production Systems | AV
 1533 Martin Luther King Jr Way
 Berkeley, CA 94709
 415-956-4100 www.shalleck.com



Oakland Housing Authority

OAKLAND HOUSING AUTHORITY - COMMISSIONER ROOM AV

2648 E. 14TH STREET,
 SUITE #801
 OAKLAND, CA 94601

PROJECT # XX-XXX

MARK	DATE	DESCRIPTION
	12/10/20	100% DD
	01/08/21	95% CD
	02/03/21	100% CD

DRAWING TITLE
AV MOUNTING DETAILS

ISSUE DATE 02-03-2021	DRAWING NO. AV711
DRAWN BY GTEH	CHECKED BY IdH

ATTACHMENTS

(FORMS / DOCUMENTS)

As Indicated in the Table of Contents

Qualifications Statement

**OAKLAND HOUSING AUTHORITY
CONTRACT COMPLIANCE & GENERAL SERVICES**

QUALIFICATIONS STATEMENT (Page 1 of 3)

This statement must be fully completed and submitted with the bid. (It shall be retained on file for one calendar year.)

All questions must be answered, with responses clear and complete. Attach additional pages if needed.

The undersigned certifies under oath that the information provided herein is true and sufficiently complete so as not to be misleading.

Submitted to: Oakland Housing Authority
Address: 1805 Harrison Street, 2nd Floor
Oakland, CA 94612

Submitted by: _____

Name: _____

Address: _____

Name of Project: **IFB # 21-005 Boardroom Audio Visual Renovations**

Type of work/Location:

License Required: C-7 and/or C-10

A. Organization

- How many years has your company been in business as a Contractor in the State of California for the above type of work?
- How many years has your company been in business under its present business name in the State of California?
- If your company a corporation, answer the following
 - i. Date of incorporation
 - ii. State of incorporation
 - iii. President's name:
 - iv. Applicable business and trade licenses

**OAKLAND HOUSING AUTHORITY
CONTRACT COMPLIANCE & GENERAL SERVICES**

QUALIFICATIONS STATEMENT (Page 2 of 3)

- If your company a partnership, answer the following:
 - i. Date of licensing
 - ii. Type of partnership
 - iii. Name(s) of general partner(s):
- If your company individually owned, answer the following:
 - i. Date of licensing
 - ii. Name of owner
- How many employees does your company currently employ?
- How many Supervisors and Foreman does your company employ?

B. Licensing

- List jurisdictions and trade categories in which your company is legally qualified to do business and indicate registration or license numbers, if applicable.

C. Experience:

- List all Claims and Suits within the last five (5) years. (If the answers to any of the questions below are yes, please attach details.)
- Has your company ever failed to complete any work awarded to it?
 Yes No
- If yes, what was the name of the contract and what was the reason for default?

**OAKLAND HOUSING AUTHORITY
CONTRACT COMPLIANCE & GENERAL SERVICES**

QUALIFICATIONS STATEMENT (Page 3 of 3)

- Has your company ever refused to sign a contract after award of the bid?
 Yes **No**

- If yes, what was the name of the contract and reason for refusal?

- Has your company or subsidiaries or principals ever been debarred from government contracts?
 Yes **No**

- If yes, please identify party and state the reason.

- Are there any judgments, claims, arbitration proceedings or suits pending or outstanding against your company or its officers? If so, please list.

- Has your company filed any law suits or requested arbitration with regards to construction contracts within the last five years? If so, please list.

D. Bonding/Financial Information:

- Surety:

- Name of bonding company:

- Name and address of agent:

- Upon request, will you complete a detailed financial statement and furnish any other information required by the Oakland Housing Authority?

 Yes **No**

The undersigned hereby authorizes and requests any person, firm or corporation to furnish any information request by the Oakland Housing Authority, verifying the declarations included in this Statement of Qualifications.

By: _____ Date: _____

Title: _____

Profile and Certification Form

PROFILE AND CERTIFICATION FORM (Page 1 of 3)

(1) Prime ____ Sub-contractor ____ (This form must be completed by and for each).

(2) Name of Firm: _____ Telephone: _____ Fax: _____

(3) Street Address, City, State, Zip: _____

(4) Primary Contact for this Project: _____ Email Address: _____

(5) Identify Principals/Partners in Firm (Attach *professional resumes* for each):

NAME	TITLE	% OF OWNERSHIP

(6) Identify the individual(s) that will act as project manager and any other supervisory personnel that will work on project; please attach *professional resumes* for each. (Do not duplicate any resumes required above):

NAME	TITLE

(7) Bidder Diversity Statement: You must circle all of the following that apply to the ownership of this firm and enter where provided the correct percentage (%) of ownership of each:

- Caucasian American (Male) _____%
 Public-Held Corporation _____%
 Government Agency _____%
 Non-Profit Organization _____%

Resident- (RBE), Minority- (MBE), or Woman-Owned (WBE) Business Enterprise (Qualifies by virtue of 51% or more ownership and active management by one or more of the following:

- Resident-Owned* _____%
 African American _____%
 **Native American _____%
 Hispanic American _____%
 Asian/Pacific American _____%
 Hasidic Jew _____%
 Asian/Indian American _____%

- Woman-Owned (MBE) _____%
 Woman-Owned (Caucasian) _____%
 Disabled Veteran _____%
 Small Business _____%
 Other (Specify): _____%

If applicable, WMBE Certification Number: _____

Certified by (Agency): _____

(8) Federal Tax ID No.: _____

(9) Business Name as Listed on the California Secretary of State Website: _____

(10) California Secretary of State Entity Number: _____

(11) [APPROPRIATE JURISDICTION] Business License No.: _____

(12) State of _____ License Type and No.: _____

* The undersigned party submitting this bid hereby certifies that the firm can meet and comply with OHA's "Section 3 Requirements" attached hereto. (See 'Section 3 Requirements Form and Action Plan')

PROFILE AND CERTIFICATION FORM (Page 2 of 3)

(13) Vendor Diversity Outreach Requirements: The Authority requires vendors/contractors/proposers undertake good faith efforts to ensure that Minority Business Enterprises and Woman Business Enterprises are provided opportunities to contract with the Authority for the delivery of goods and services. The undersigned, as an authorized representative of the business identified herein, hereby declares that the following statements are, to the best of his/her/its knowledge, true and correct with respect to the efforts made in a "good-faith" attempt to comply with the Authority's outreach requirements and that said business will provide to the Authority evidence of the efforts described herein within three working days of such request.

a.) Written Notice

- Not less than _____ days prior to the submission of the bids/proposals, we provided written notice of our interest in bidding and requested assistance from organizations that provide assistance in the recruitment and placement of MBE/WBE and other business enterprises. *[NOTE: You may be requested to submit a list of organizations that provided such assistance.]*
- We **did not** provide such written notice.

b.) Advertisement

- Not less than _____ days prior to the submission of the bids/proposals, the undersigned party advertised for bids/proposals from interested MBE/WBE businesses in more than one daily or weekly newspaper, trade association publications, minority or trade oriented publications, trade journals, internet, social media and/or other media. *[Proof of advertisement must be attached.]*
- The undersigned party **did not** advertise for bids from MBE/WBE businesses.

c.) Participation

- The undersigned party directly solicited MBE/WBE businesses that have agreed to participate in this contract if awarded.
- The undersigned party **did not** obtain participation by MBE/WBE businesses.

(14) Insurance Certification: The undersigned party submitting this bid hereby certifies that the firm can meet and comply with OHA's "Insurance Requirements" attached hereto. *(See 'OHA Insurance Requirements' attached)* Copies of insurance certificates may be submitted with the proposal or the information completed below. The insurance policies must name OHA as an additional insured and maintained throughout the term of the contract. The firm(s) must provide OHA with Certificates of Insurance for the preceding coverage. The insurance policies must provide a 30-day notice of cancellation and be primary to any other insurance carried by OHA.

Worker's Compensation Insurance Carrier: _____

Policy No.: _____ Expiration Date: _____

General Liability Insurance Carrier: _____

Policy No. _____ Expiration Date: _____

Professional Liability Insurance Carrier: _____

Policy No. _____ Expiration Date: _____

(15) Debarred Statement: Has this firm, or any principal(s) ever been debarred from providing any services by the Federal Government, any state government, the State of _____, or any local government agency within or without the State of _____? Yes No

If "Yes," please attach a full detailed explanation, including dates, circumstances and current status.

PROFILE AND CERTIFICATION FORM (Page 3 of 3)

- (16) Disclosure Statement: Does this firm or any principals thereof have any current, past personal or professional relationship with any Commissioner or Officer of the HA? Yes No

If "Yes," please attach a full detailed explanation, including dates, circumstances and current status.

- (17) Non-Collusive Affidavit: The undersigned party submitting this bid hereby certifies that such bid is genuine and not collusive and that said bidder entity has not colluded, conspired, connived or agreed, directly or indirectly, with any bidder or person, to put in a sham bid or to refrain from bidding, and has not in any manner, directly or indirectly sought by agreement or collusion, or communication or conference, with any person, to fix the bid price of affiant or of any other bidder, to fix overhead, profit or cost element of said bid price, or that of any other bidder or to secure any advantage against the OHA or any person interested in the proposed contract; and that all statements in said bid are true.

- (18) Indemnification Certification: The undersigned party submitting this bid hereby certifies that the firm expressly agrees to indemnify, defend, hold harmless and indemnify the Authority, and its respective commissioners, members, officers, agents and employees of and from all claims, loss, damage, injury, actions, causes of action and liability of every kind, nature and description directly or indirectly arising out of or connected with the performance of this Contract and any of Contractor's operations or activities related thereto, excluding the willful misconduct or the gross negligence of the person or entity seeking to be defended, indemnified or held harmless.

- (19) Section 3 and Labor Compliance: The undersigned party submitting this bid hereby certifies that the firm can meet and comply with OHA's "Section 3 Requirements" and Labor Compliance standards including submission of certified payrolls and paying employees the required prevailing wages. (*Section 3 Information, Economic Opportunities Policy, and Labor Compliance standards may be found on our website at [www.oakha.org/Business Opportunities/Section 3.](http://www.oakha.org/Business%20Opportunities/Section%203)*)

- (20) Labor Code Certification: The undersigned party submitting this bid hereby certifies that party submitting this bid hereby is aware of the provisions of Section 3700 of the Labor Code which require every employer to be insured against liability for worker's compensation or to undertake self insurance in accordance with the provisions of that Code, and will comply with such provisions before commencing the performance of the work of this Agreement".

- (21) Verification Statement: The undersigned party hereby states that by completing and submitting this form he/she is verifying that all information provided herein is, to the best of his/her knowledge, true and accurate, and agrees that if the HA discovers that any information entered herein is false, that shall entitle the HA to not consider nor make award or to cancel any award with the undersigned party.

Signature

Date

Printed Name

Company

Section 3 Business Certification and Action Plan



Oakland Housing
Authority

Contractor's Summary Guide to Section 3 Compliance

The purpose of Section 3 of the Housing and Urban Development Act of 1968 as amended (12 U.S.C. 1701u) (section 3), and 24 CFR Part 135, is to ensure that training, employment and other economic opportunities generated by certain HUD financial assistance shall, to the greatest extent feasible, and consistent with existing federal, state and local laws and regulations, be directed to low- and very low-income persons, particularly those who are recipients of government assistance for housing, and to business concerns, which provide economic opportunities to low- and very low-income persons." **For the complete text of the Section 3 regulations, visit www.hud.gov/section3.**

Oakland Housing Authority's Section 3 Economic Opportunities Policy (included in bid documents)

Oakland has one of the highest unemployment rates in the Bay Area. Oakland Housing Authority (OHA) residents make up over 10% of Oakland's population. OHA developed its **Economic Opportunities Policy (EOP)** to comply with the Housing and Urban Development (HUD) Section 3 regulations and ensure that, to the greatest extent feasible, economic opportunities are provided to low- and very low-income persons and to Section 3 business concerns within the city of Oakland. All contractors undertaking Section 3 covered projects and activities on behalf of OHA are expected, to the greatest extent feasible, to meet the numerical goals set forth below. The policy does not apply to contractors who furnish only materials or supplies and do not undertake installation of materials or supplies. The **EOP** is also available from OHA's website www.oakha.org/procurement/sec3EcoOpportPolicy.pdf.

Section 3 Requirement for All Bidders

As part of the application or bidding process, a Section 3 Business Preference and Action Plan are included in bid documents. Contractors have the option to request Certification as a Section 3 business; however, every proposer **MUST** complete the Action Plan and submit it with their bid, even if no hires are projected.

Certification for Business Seeking Section 3 Business Preference form: Everyone must complete the top portion (check one box, name of business etc.) and sign at the bottom. Fill in the other parts **ONLY** if you are claiming Section 3 business status.

Action Plan (3 pages): Everyone must complete the top portion listing your company etc., where applicable, and sign every page. If you **do not** anticipate new hires, note that in the table on page 1 and 3. If you **do** anticipate new hires, then use page 1 to detail the job categories and page 3 to describe how you will fill those positions.

Section 3 Requirements for Awardees

Baseline Reporting and Hiring Projections Form

Prior to the Notice to Proceed, the contractor/subcontractor will be responsible for documenting the current workforce (baseline) and providing more accurate hiring projections per job classification than those described in the Action Plan. The Plan that is approved will become part of the contractual agreements.

Hiring Goals

The Section 3 requirement is triggered when there is a need for **new** economic opportunities, such as individual employment, contracting, or subcontracting. The regulation requires that contractors and subcontractors provide, **to the greatest extent feasible**, economic opportunities (training, employment, and contracting) to low and very-low income residents Section 3 businesses.

Contractors and subcontractors are required to make every effort to the greatest extent feasible to meet the OHA's numerical hiring goals of having Section 3 qualified employees make up **30% of their total new-hires**. **Firms must seek to maintain this percentage throughout the life of the project.** If these goals are not met, the contractors are expected to show documentation demonstrating their efforts to hire Section 3 candidates by exhausting all available hiring sources. While a contractor receives credit for hiring low-income residents of Oakland, **first priority should be given to residents of the Oakland Housing Authority**. This includes residents in both the public housing and Section 8 programs.

Hiring Priorities

First priority (OHA residents): Residents of the development where the work is being performed
Second priority (OHA residents): Other residents of Oakland Housing Authority owned or managed properties
Third priority (Oakland residents): Other residents within the city of Oakland that meet the low-income requirements (see definition of **Section 3 Resident** below).

Resident Referral Process

OHA is committed to working with general contractors and subcontractors to help them reach their Section 3 goals. Therefore, we have established a pre-screening and referral process to identify qualified OHA residents who satisfy the first and second hiring priorities (above). This process ensures that each candidate is in good standing with the housing authority and has a background that qualifies him/her to perform the essential functions of the job.

To ensure the best possible match, it is important that contractors communicate their hiring needs to OHA well in advance of the project start date. We request at least 2 business days' notice before the employee's start date, but earlier notice is preferred. We will work with you to identify a pool of candidates for each position. If we cannot provide you with a candidate, we will grant you a waiver to document your efforts to meet the Section 3 goals.

Union Contractors: OHA's Family and Community Partnerships department (FCP) has established a list of current OHA residents in construction trade unions that is sent to contractors on a regular basis. If there is no candidate that meets your hiring needs, you are encouraged to consider sponsoring an OHA resident who is not a member of a trade union to meet your Section 3 hiring goals.

Please contact **OHA's Dan Abrami at 510.587.5127 or dabrami@oakha.org** for a list of qualified residents, to request a candidate, or verify the Section 3 eligibility of any prospective hire. For more information about providing economic opportunities to OHA resident's contact:

Employment Development Coordinator
Family & Community Partnerships Department

Phone: 510.587.5127

Fax: 510.587.5141

Email: dabrami@oakha.org

New Hire Section 3 Information Form

General contractors and subcontractors will be provided this form upon award. Every **new hire** should be requested to complete the form. The form provides the means to determine Section 3 eligibility of the employee. The forms should be submitted to OHA as soon as possible after hiring for verification of Section 3 status.

Monthly Reports

OHA requires monthly reports listing all new hires and Section 3 hires from all contractors and subcontractors on Section 3 covered projects. A sample report will be provided. Reports shall be due on the fifth day of each month for the preceding month. These reports shall be submitted to:

Rufus Davis, Labor and Section 3 Compliance Officer

Phone: 510.587.2176

Email: rdavis@oakha.org

Record Maintenance and Documentation

All projects and activities that are subject to Section 3 requirements shall maintain comprehensive documentation of their Section 3 outreach efforts and implementation activities. Section 3 documentation files should be clearly maintained and be available for review by Oakland Housing Authority and/or HUD officials.

Compliance Reviews

OHA staff will conduct regular compliance reviews, which consist of comprehensive analysis and evaluation of the contractor's compliance with Section 3. Where noncompliance is found, OHA will notify the contractor of the deficiency and make recommendations for corrective actions.

Useful Definitions

Business Concern

A business entity formed in accordance with state law, and which is licensed under state, county or municipal law to engage in the type of business activity for which it was formed.

“Greatest Extent Feasible”

Recipients of Section 3 financial assistance must make every effort within their disposal to meet the regulatory requirements. For instance, this may mean going a step beyond normal notification procedures for employment and contracting opportunities by developing strategies that will specifically target Section 3 residents and businesses for these new economic opportunities.

Household Income Levels

Low and very-low income limits are determined annually by HUD. These limits are typically established at 80 percent and 50 percent of the median income for each locality by household size or number of people residing in one house. HUD income limits can be obtained from www.huduser.org/portal/datasets/il.html.

New Hire

A new hire means a full-time employee for a new permanent, temporary, or seasonal position that is created as a direct result of the expenditure of federal funds on Section 3 covered projects. Any employee that is not on the payroll of a contractor or developer on the day [i.e., that a purchase order is issued or the day a contract is signed or agreed upon] that the Section 3 covered assistance was provided, is considered a new hire.

Section 3 Business Concern

A business concern that meets one or more of the following requirements:

- 51% or more owned by Section 3 residents
- 30% or more of permanent, full-time workforce consists of Section 3 residents
- Provides evidence to subcontract at least 25% of the dollar awarded to qualified Section 3 businesses

Section 3 Resident

- (1) An Oakland Housing Authority public housing resident or Section 8 voucher holder; or
- (2) An individual who resides in the service area (Oakland) in which the Section 3 covered assistance is expended, and whose income status is as follows:

Number of People in Household	Annual Household Income Limits (Source: 24 CFR 570.3)
1	\$26,050 or less
2	\$29,750 or less
3	\$33,450 or less
4	\$37,150 or less
5	\$40,150 or less
6	\$43,100 or less
7	\$46,100 or less
8	\$49,050 or less

(Income limits eff. 03/01/2019)

Questions regarding the Oakland Housing Authority
Section 3 Program should be addressed to:

Rufus Davis, Labor and Section 3 Compliance Officer
Oakland Housing Authority
1805 Harrison Street, First Floor
Oakland, CA 94612
Phone: 510.587.2176
Email: rdavis@oakha.org



Section 3 Business Certification and Action Plan

Section 3 Business Certification – 1 page

Check this box if you are **not** claiming Section 3 business status. Complete Section 1 and the signature block at the bottom of this page and proceed to the **Section 3 Action Plan**.

SECTION 1

Company Name _____

Address _____

Type of Business (Check One): Corporation Partnership Sole Proprietorship Other

Project (Bid/RFP #) _____ Business Activity _____

SECTION 2

Current Section 3 Status: The undersigned bidder/proposer hereby certifies that it is a Section 3 business concern and attaches relevant documentation, **as applicable**, to support such claim.

Select only one option.

1. A business claiming status as a Section 3 resident-owned business concern (ROB):

Initial here to select this option _____

- | | |
|---|--|
| <input type="checkbox"/> OHA resident lease | <input type="checkbox"/> List of owners/stockholders and % of each |
| <input type="checkbox"/> Copy of receipt of public assistance | <input type="checkbox"/> Latest board minutes appointing officers |
| <input type="checkbox"/> Other evidence of income status | <input type="checkbox"/> Articles of incorporation |
| <input type="checkbox"/> Fictitious or Assumed Business Name Certificate | <input type="checkbox"/> Partnership agreement |
| <input type="checkbox"/> Organization chart with names and titles and brief job description | |

2. A business claiming Section 3 status because at least 30% of its permanent full-time employees are currently Section 3 residents or, within 3 years of the date of first employment with the business concern, were Section 3 residents. If a business claims this option, the 30% employment requirement must be maintained for the entire project. **Initial here to select this option** _____

- | | |
|--|---|
| <input type="checkbox"/> List of all current full time employees | <input type="checkbox"/> List of all employees claiming Section 3 status |
| <input type="checkbox"/> OHA residential lease (less than 3 years from date of employment) | <input type="checkbox"/> Other evidence of Section 3 status (less than 3 years from date of employment) |

3. A business claiming Section 3 status by subcontracting 25% or more of the dollar award to qualified Section 3 businesses (as set forth in Options 1 and 2). **Initial here to select this option** _____

- Provide a list of intended Section 3 business subcontractors with subcontract amount.
- Include this Section 3 Certification form and all supporting documentation for each planned Section 3 business subcontractor.

If you are or become certified as a Section 3 business, do you grant OHA permission to share your business contact information with firms seeking to contract with Section 3 businesses? Yes No

I attest that the above information is true and correct.

Signature

Printed Name

Title

Date



Section 3 Action Plan (2 pages)

All firms and individuals bidding on any Section 3 covered contract with the Oakland Housing Authority (OHA) **MUST COMPLETE AND SUBMIT THIS ACTION PLAN WITH THE BID, OFFER, OR PROPOSAL.** Any solicitation response that does not include this document (completed and signed) will be considered non-responsive and not eligible for award.

PRELIMINARY STATEMENT OF CURRENT WORKFORCE AND HIRING NEEDS

THIS PLAN OUTLINES YOUR COMMITMENT TO OHA'S SECTION 3 HIRING GOALS

COMPANY NAME: _____

ADDRESS: _____

PROJECT (BID/RFP#): _____ GENERAL SUBCONTRACTOR

JOB CATEGORY: EXAMPLES ADMINISTRATIVE ASST., OFFICE MANAGER, CLERK, PROJECT MANAGER, EQUIPMENT MECHANIC, JANITORIAL, HOUSING MANAGEMENT, LABORER, LANDSCAPER, GLAZIER-JOURNEYMAN, GLAZIER-APPRENTICE, PLUMBER-JOURNEYMAN, PLUMBER-APPRENTICE	(A) # of CURRENT Employees (Core Staff)	(B) PROJECTED # of New Hires FOR THIS PROJECT	(C) PROJECTED # of Section 3 Hires	(D) PROJECTED Section 3 Hires as a Percentage of NEW HIRES
				%
				%
				%
				%
				%
				%
				%
				%
				%
				%
OTHER, PLEASE LIST.				%

___ (Check here and attach another sheet if applicable)

Check this box if contractor does not anticipate triggering the regulation by the need for new hiring or subcontracting opportunities. Complete the signature block at the bottom of this page.

I attest that the above information is true and correct. The company certifies that the above table represents the appropriate number of employee positions and also represents the number of Section 3 employees that the company proposes to hire.

Signature

Printed Name

Title

Date

Section 3 Action Plan (continued)

EFFORTS TO ACHIEVE SECTION 3 COMPLIANCE

Indicate the efforts your organization will take to direct employment and other economic opportunities, to the greatest extent feasible, to low-income residents. Think about how you can leverage your resources and expertise to foster training and employment opportunities for Section 3 residents. **Examples** include, but are not limited to, the following. Check all that apply.

- Refer to any list of pre-screened job-ready applicants provided by OHA's Department of Family and Community Partnerships (FCP) (*REQUEST A LIST from FCP at S3hire@oakha.org or 510-587-5127*).
- Utilize and manage union privileges such as name-call, transfer, rehire, and sponsorship.
- Financially sponsor OHA resident(s) in trainings, certifications, professional mentorships, etc.
- Distribute flyers door-to-door to OHA owned and managed properties.
- Run multiple advertisements in local media such as newspapers and radio stations, and/or Internet-based job-posting websites announcing the hiring and contracting opportunities.
- Contract with certified Section 3 businesses, in construction and non-construction trades (*REQUEST A LIST from Rufus Davis at OHA, rdavis@oakha.org or 510-587-2176*).
- Post signs at the entrance to the job site stating that it is a Section 3 covered project.
- Sponsor (schedule, advertise, finance, or provide in-kind services) a job informational meeting to be conducted by the housing authority or a contractor representative.
- Undertake job counseling, education and related programs in association with local educational institutions.
- Other: _____

I attest that the above information is true and correct.

Signature

Printed Name

Title

Date

SECTION 3 CLAUSE (24 CFR 135.38)

This contract is subject to the following conditions under Section 3 of the Housing and Urban Development Act of 1968, as amended, 12 U.S.C. 1701u (Section 3).

- A. The work to be performed under this contract is subject to the requirements of Section 3 of the Housing and Urban Development Act of 1968, as amended, 12 U.S.C. 1701u (Section 3). The purpose of Section 3 is to ensure that employment and other economic opportunities generated by HUD assistance or HUD-assisted projects covered by Section 3, shall, to the greatest extent feasible, be directed to low and very low-income persons, particularly persons who are recipients of HUD assistance for housing.
- B. The parties to this contract agree to comply with HUD's regulations in 24 CFR Part 135, which implement Section 3. As evidenced by their execution of this contract, the parties to this contract certify that they are under no contractual or other impediment that would prevent them from complying with the Part 135 regulations.
- C. The contractor agrees to send to each labor organization or representative of workers with which the contractor has a collective bargaining agreement or other understanding, if any, a notice advising the labor or organization or workers' representative of the contractor's commitments under this Section 3 clause, and will post copies of the notice in conspicuous places at the work site where both employees and applicants for training and employment positions can see the notice. The notice shall describe the Section 3 preference, shall set forth minimum number and job titles subject to hire, availability of apprenticeship and training positions, the qualifications for each; and the name and location of the person(s) taking applications for each of the positions; and the anticipated date the work shall begin.
- D. The contractor agrees to include this Section 3 clause in every subcontract subject to compliance with regulations in 24 CFR Part 135, and agrees to take appropriate action, as provided in an applicable provision of the subcontract or in this Section 3 clause, upon finding that the subcontractor is in violation of the regulations in 24 CFR Part 135. The contractor will not subcontract with any subcontractor where the contractor has notice or knowledge that the subcontractor has been found in violation of the regulations in 24 CFR Part 135.
- E. The contractor will certify that any vacant employment positions, including training positions that are filled (1) after the contractor is selected but before the contract is executed, and (2) with persons other than those to whom the regulations of 24 CFR Part 135 require employment opportunities to be directed, were not filled to circumvent the contractor's obligations under 24 CFR Part 135.
- F. Noncompliance with HUD's regulations in 24 CFR Part 135 may result in sanctions, termination of this contract for default, and debarment or suspension from future HUD assisted contracts.
- G. With respect to work performed in connection with Section 3 covered Indian housing assistance, Section 7(b) of the Indian Self-Determination and Education Assistance Act (25 U.S.C. 450e) also applies to the work to be performed under this contract. Section 7(b) requires that to the greatest extent feasible (preference and opportunities for training and employment shall be given to Indians, and (ii) preference in the award of contracts and subcontracts shall be given to Indian organizations and Indian-owned Economic Enterprise. Parties to this contract that are subject to the provisions of Section 3 and Section 7(b) agree to comply with Section 3 to the maximum extent feasible, but not in derogation of compliance with Section 7(b).

Subcontractor List

SUBCONTRACTOR LIST

IFB No. 21-005

(PAGE 1 OF 2)

The Authority requires all bidders to identify all subcontractors* proposed as part of this bid. Failure to provide all the information herewith requested may result in rejection of the bid.

Subcontractor	Classification	Amount	License No.	Ownership (check)		
				MBE	WBE	LBE
1.						
2.						
3.						
4.						
5.						
6.						
7.						
8.						
9.						
10.						
11.						
12.						
13.						
14.						
15.						

(Attach additional page if necessary.)

MBE - Minority Business Enterprise

WBE - Woman Business Enterprise

LBE - Local Business Enterprise (Offices located within the Oakland city limit)

**List Sub-Contractors for work in excess of ½ of 1 percent of Bidders total bid [Reference: California Public Contract Code Section 4104(a)(1)].*

SUBCONTRACTOR LIST

IFB No. 21-005

(PAGE 2 OF 2)

The Authority requires all bidders to identify all work that is **not** to be performed by a listed subcontractor and identifies who will perform the work, including the estimated cost for completing the specified work. Failure to provide all the information herewith requested may result in rejection of the bid.

Classification/Type of Work	Amount
1.	
2.	
3.	
4.	
5.	
6.	
7.	
8.	
9.	
10.	

Date _____

Name of Bidder _____

By _____

By _____

Title _____

Address _____

Phone _____

Federal I.D. Number _____

Asbestos Notice to Contractors and
Acknowledgement Form

To: All Contractors at OHA

SUBJECT: ASBESTOS NOTICE TO CONTRACTORS (Connelly Act, AB 3713)

State law requires notification to all Oakland Housing Authority (OHA) Contractors of the presence or the possible presence of asbestos in certain building materials used in the construction of OHA buildings.

OHA is conducting an on-going survey to identify those areas at OHA where asbestos containing building materials (ACBM) are present. For specific locations of ACBM, please contact Artesia Dupree at (510) 874-1680.

Certain buildings at OHA contain non-friable asbestos materials in public access areas. These materials include vinyl asbestos floor tiles, transite, drywall and joint compound, wall texturing, roofing, plaster, stucco and/or linoleum sheet flooring. The asbestos in these materials under normal conditions do not pose any danger to the user. If the material is cracked, drilled, sanded, or otherwise disturbed, however, it could result in the release of asbestos fibers into the air that could present a health risk. Such work must only be performed by trained personnel using proper work practices, containment equipment, and personal protection.

Some other areas contain sprayed-on acoustical material containing asbestos. These materials may be reduced to powder by hand pressure, but do not present a problem as long as they are not disturbed. Only trained workers with the proper equipment should perform work that would have the potential to disturb such materials.

Some fire doors used in stairwells, and the entrances to mechanical rooms and cores in the larger buildings also contain asbestos. These doors are usually wooden and have a metal label on the inside edge or top identifying them as having a type "B" fire rating or a rating of one hour or greater. As long as these doors are intact, they pose no health risk to building occupants or contractors. Only trained workers with the proper equipment should perform work that would have the potential to disturb such materials.

Some larger buildings have asbestos materials in areas of restricted public access such as mechanical rooms and cores. In very few instances, asbestos insulated pipes and ductwork are in public areas. As long as the materials are not damaged or disturbed and the outer canvas cover or metal sheathing on the pipes is intact, the insulation presents no health problem. Only trained workers with the proper equipment should perform work that would have the potential to disturb such materials.

As building materials are tested and/or abated, the database for asbestos is continually updated.

If you have any questions, or would like more information about asbestos, please contact the Asbestos Program Manager, Artesia Dupree at (510) 874-1680.

Please sign and return the attached certification that you have received a copy of this document; Asbestos: Notice to Contractors.

Acknowledgement of receipt of disclosure:

I hereby acknowledge that I have received a copy of the document entitled: Asbestos: Notice to Contractors provided to me by the Oakland Housing Authority (OHA).

Signature: _____ Date: _____

Printed Name: _____

Company Name: _____

***This form must be returned to OHA before beginning any maintenance/contracting work on OHA buildings.

U.S. Department of Housing and Urban
Development – Representations, Certifications, and
Other Statements of Bidders (Form HUD-5369-A)

**U.S. Department of Housing
and Urban Development**
Office of Public and Indian Housing

**Representations, Certifications,
and Other Statements of Bidders**
Public and Indian Housing Programs

Representations, Certifications, and Other Statements of Bidders

Public and Indian Housing Programs

Table of Contents

Clause	Page
1. Certificate of Independent Price Determination	1
2. Contingent Fee Representation and Agreement	1
3. Certification and Disclosure Regarding Payments to Influence Certain Federal Transactions	1
4. Organizational Conflicts of Interest Certification	2
5. Bidder's Certification of Eligibility	2
6. Minimum Bid Acceptance Period	2
7. Small, Minority, Women-Owned Business Concern Representation	2
8. Indian-Owned Economic Enterprise and Indian Organization Representation	2
9. Certification of Eligibility Under the Davis-Bacon Act	3
10. Certification of Nonsegregated Facilities	3
11. Clean Air and Water Certification	3
12. Previous Participation Certificate	3
13. Bidder's Signature	3

1. Certificate of Independent Price Determination

(a) The bidder certifies that--

(1) The prices in this bid have been arrived at independently, without, for the purpose of restricting competition, any consultation, communication, or agreement with any other bidder or competitor relating to (i) those prices, (ii) the intention to submit a bid, or (iii) the methods or factors used to calculate the prices offered;

(2) The prices in this bid have not been and will not be knowingly disclosed by the bidder, directly or indirectly, to any other bidder or competitor before bid opening (in the case of a sealed bid solicitation) or contract award (in the case of a competitive proposal solicitation) unless otherwise required by law; and

(3) No attempt has been made or will be made by the bidder to induce any other concern to submit or not to submit a bid for the purpose of restricting competition.

(b) Each signature on the bid is considered to be a certification by the signatory that the signatory--

(1) Is the person in the bidder's organization responsible for determining the prices being offered in this bid or proposal, and that the signatory has not participated and will not participate in any action contrary to subparagraphs (a)(1) through (a)(3) above; or

(2) (i) Has been authorized, in writing, to act as agent for the following principals in certifying that those principals have not participated, and will not participate in any action contrary to subparagraphs (a)(1) through (a)(3) above.

_____ [insert full name of person(s) in the bidder's organization responsible for determining the prices offered in this bid or proposal, and the title of his or her position in the bidder's organization];

(ii) As an authorized agent, does certify that the principals named in subdivision (b)(2)(i) above have not participated, and will not participate, in any action contrary to subparagraphs (a)(1) through (a)(3) above; and

(iii) As an agent, has not personally participated, and will not participate in any action contrary to subparagraphs (a)(1) through (a)(3) above.

(c) If the bidder deletes or modifies subparagraph (a)2 above, the bidder must furnish with its bid a signed statement setting forth in detail the circumstances of the disclosure.

[] [Contracting Officer check if following paragraph is applicable]

(d) Non-collusive affidavit. (applicable to contracts for construction and equipment exceeding \$50,000)

(1) Each bidder shall execute, in the form provided by the PHA/IHA, an affidavit to the effect that he/she has not colluded with any other person, firm or corporation in regard to any bid submitted in response to this solicitation. If the successful bidder did not submit the affidavit with his/her bid, he/she must submit it within three (3) working days of bid opening. Failure to submit the affidavit by that date may render the bid nonresponsive. No contract award will be made without a properly executed affidavit.

(2) A fully executed "Non-collusive Affidavit" [] is, [] is not included with the bid.

2. Contingent Fee Representation and Agreement

(a) Definitions. As used in this provision:

"Bona fide employee" means a person, employed by a bidder and subject to the bidder's supervision and control as to time, place, and manner of performance, who neither exerts, nor proposes to exert improper influence to solicit or obtain contracts nor holds out as being able to obtain any contract(s) through improper influence.

"Improper influence" means any influence that induces or tends to induce a PHA/IHA employee or officer to give consideration or to act regarding a PHA/IHA contract on any basis other than the merits of the matter.

(b) The bidder represents and certifies as part of its bid that, except for full-time bona fide employees working solely for the bidder, the bidder:

(1) [] has, [] has not employed or retained any person or company to solicit or obtain this contract; and

(2) [] has, [] has not paid or agreed to pay to any person or company employed or retained to solicit or obtain this contract any commission, percentage, brokerage, or other fee contingent upon or resulting from the award of this contract.

(c) If the answer to either (a)(1) or (a)(2) above is affirmative, the bidder shall make an immediate and full written disclosure to the PHA/IHA Contracting Officer.

(d) Any misrepresentation by the bidder shall give the PHA/IHA the right to (1) terminate the contract; (2) at its discretion, deduct from contract payments the amount of any commission, percentage, brokerage, or other contingent fee; or (3) take other remedy pursuant to the contract.

3. Certification and Disclosure Regarding Payments to Influence Certain Federal Transactions (applicable to contracts exceeding \$100,000)

(a) The definitions and prohibitions contained in Section 1352 of title 31, United States Code, are hereby incorporated by reference in paragraph (b) of this certification.

(b) The bidder, by signing its bid, hereby certifies to the best of his or her knowledge and belief as of December 23, 1989 that:

(1) No Federal appropriated funds have been paid or will be paid to any person for influencing or attempting to influence an officer or employee of any agency, a Member of Congress, an officer or employee of Congress, or an employee of a Member of Congress on his or her behalf in connection with the awarding of a contract resulting from this solicitation;

(2) If any funds other than Federal appropriated funds (including profit or fee received under a covered Federal transaction) have been paid, or will be paid, to any person for influencing or attempting to influence an officer or employee of any agency, a Member of Congress, an officer or employee of Congress, or an employee of a Member of Congress on his or her behalf in connection with this solicitation, the bidder shall complete and submit, with its bid, OMB standard form LLL, "Disclosure of Lobbying Activities;" and

(3) He or she will include the language of this certification in all subcontracts at any tier and require that all recipients of subcontract awards in excess of \$100,000 shall certify and disclose accordingly.

(c) Submission of this certification and disclosure is a prerequisite for making or entering into this contract imposed by section 1352, title 31, United States Code. Any person who makes an expenditure prohibited under this provision or who fails to file or amend the disclosure form to be filed or amended by this provision, shall be subject to a civil penalty of not less than \$10,000, and not more than \$100,000, for each such failure.

(d) Indian tribes (except those chartered by States) and Indian organizations as defined in section 4 of the Indian Self-Determination and Education Assistance Act (25 U.S.C. 450B) are exempt from the requirements of this provision.

4. Organizational Conflicts of Interest Certification

The bidder certifies that to the best of its knowledge and belief and except as otherwise disclosed, he or she does not have any organizational conflict of interest which is defined as a situation in which the nature of work to be performed under this proposed contract and the bidder's organizational, financial, contractual, or other interests may, without some restriction on future activities:

- (a) Result in an unfair competitive advantage to the bidder; or,
- (b) Impair the bidder's objectivity in performing the contract work.

[] In the absence of any actual or apparent conflict, I hereby certify that to the best of my knowledge and belief, no actual or apparent conflict of interest exists with regard to my possible performance of this procurement.

5. Bidder's Certification of Eligibility

(a) By the submission of this bid, the bidder certifies that to the best of its knowledge and belief, neither it, nor any person or firm which has an interest in the bidder's firm, nor any of the bidder's subcontractors, is ineligible to:

(1) Be awarded contracts by any agency of the United States Government, HUD, or the State in which this contract is to be performed; or,

(2) Participate in HUD programs pursuant to 24 CFR Part 24.

(b) The certification in paragraph (a) above is a material representation of fact upon which reliance was placed when making award. If it is later determined that the bidder knowingly rendered an erroneous certification, the contract may be terminated for default, and the bidder may be debarred or suspended from participation in HUD programs and other Federal contract programs.

6. Minimum Bid Acceptance Period

(a) "Acceptance period," as used in this provision, means the number of calendar days available to the PHA/IHA for awarding a contract from the date specified in this solicitation for receipt of bids.

(b) This provision supersedes any language pertaining to the acceptance period that may appear elsewhere in this solicitation.

(c) The PHA/IHA requires a minimum acceptance period of [Contracting Officer insert time period] calendar days.

(d) In the space provided immediately below, bidders may specify a longer acceptance period than the PHA's/IHA's minimum requirement. The bidder allows the following acceptance period: calendar days.

(e) A bid allowing less than the PHA's/IHA's minimum acceptance period will be rejected.

(f) The bidder agrees to execute all that it has undertaken to do, in compliance with its bid, if that bid is accepted in writing within (1) the acceptance period stated in paragraph (c) above or (2) any longer acceptance period stated in paragraph (d) above.

7. Small, Minority, Women-Owned Business Concern Representation

The bidder represents and certifies as part of its bid/ offer that it --

(a) [] is, [] is not a small business concern. "Small business concern," as used in this provision, means a concern, including its affiliates, that is independently owned and operated, not dominant in the field of operation in which it is bidding, and qualified as a small business under the criteria and size standards in 13 CFR 121.

(b) [] is, [] is not a women-owned business enterprise. "Women-owned business enterprise," as used in this provision, means a business that is at least 51 percent owned by a woman or women who are U.S. citizens and who also control and operate the business.

(c) [] is, [] is not a minority business enterprise. "Minority business enterprise," as used in this provision, means a business which is at least 51 percent owned or controlled by one or more minority group members or, in the case of a publicly owned business, at least 51 percent of its voting stock is owned by one or more minority group members, and whose management and daily operations are controlled by one or more such individuals. For the purpose of this definition, minority group members are:

(Check the block applicable to you)

- [] Black Americans
- [] Asian Pacific Americans
- [] Hispanic Americans
- [] Asian Indian Americans
- [] Native Americans
- [] Hasidic Jewish Americans

8. Indian-Owned Economic Enterprise and Indian Organization Representation (applicable only if this solicitation is for a contract to be performed on a project for an Indian Housing Authority)

The bidder represents and certifies that it:

(a) [] is, [] is not an Indian-owned economic enterprise. "Economic enterprise," as used in this provision, means any commercial, industrial, or business activity established or organized for the purpose of profit, which is at least 51 percent Indian owned. "Indian," as used in this provision, means any person who is a member of any tribe, band, group, pueblo, or community which is recognized by the Federal Government as eligible for services from the Bureau of Indian Affairs and any "Native" as defined in the Alaska Native Claims Settlement Act.

(b) [] is, [] is not an Indian organization. "Indian organization," as used in this provision, means the governing body of any Indian tribe or entity established or recognized by such governing body. Indian "tribe" means any Indian tribe, band, group, pueblo, or

community including Native villages and Native groups (including corporations organized by Kenai, Juneau, Sitka, and Kodiak) as defined in the Alaska Native Claims Settlement Act, which is recognized by the Federal Government as eligible for services from the Bureau of Indian Affairs.

9. Certification of Eligibility Under the Davis-Bacon Act (applicable to construction contracts exceeding \$2,000)

(a) By the submission of this bid, the bidder certifies that neither it nor any person or firm who has an interest in the bidder's firm is a person or firm ineligible to be awarded contracts by the United States Government by virtue of section 3(a) of the Davis-Bacon Act or 29 CFR 5.12(a)(1).

(b) No part of the contract resulting from this solicitation shall be subcontracted to any person or firm ineligible to be awarded contracts by the United States Government by virtue of section 3(a) of the Davis-Bacon Act or 29 CFR 5.12(a)(1).

(c) The penalty for making false statements is prescribed in the U. S. Criminal Code, 18 U.S.C. 1001.

10. Certification of Nonsegregated Facilities (applicable to contracts exceeding \$10,000)

(a) The bidder's attention is called to the clause entitled **Equal Employment Opportunity** of the General Conditions of the Contract for Construction.

(b) "Segregated facilities," as used in this provision, means any waiting rooms, work areas, rest rooms and wash rooms, restaurants and other eating areas, time clocks, locker rooms and other storage or dressing areas, parking lots, drinking fountains, recreation or entertainment areas, transportation, and housing facilities provided for employees, that are segregated by explicit directive or are in fact segregated on the basis of race, color, religion, or national origin because of habit, local custom, or otherwise.

(c) By the submission of this bid, the bidder certifies that it does not and will not maintain or provide for its employees any segregated facilities at any of its establishments, and that it does not and will not permit its employees to perform their services at any location under its control where segregated facilities are maintained. The bidder agrees that a breach of this certification is a violation of the Equal Employment Opportunity clause in the contract.

(d) The bidder further agrees that (except where it has obtained identical certifications from proposed subcontractors for specific time periods) prior to entering into subcontracts which exceed \$10,000 and are not exempt from the requirements of the Equal Employment Opportunity clause, it will:

- (1) Obtain identical certifications from the proposed subcontractors;
- (2) Retain the certifications in its files; and
- (3) Forward the following notice to the proposed subcontractors (except if the proposed subcontractors have submitted identical certifications for specific time periods):

Notice to Prospective Subcontractors of Requirement for Certifications of Nonsegregated Facilities

A Certification of Nonsegregated Facilities must be submitted before the award of a subcontract exceeding \$10,000 which is not exempt from the provisions of the Equal Employment Opportunity clause of the prime contract. The certification may be submitted either for each subcontract or for all subcontracts during a period (i.e., quarterly, semiannually, or annually).

Note: The penalty for making false statements in bids is prescribed in 18 U.S.C. 1001.

11. Clean Air and Water Certification (applicable to contracts exceeding \$100,000)

The bidder certifies that:

(a) Any facility to be used in the performance of this contract [] is, [] is not listed on the Environmental Protection Agency List of Violating Facilities:

(b) The bidder will immediately notify the PHA/IHA Contracting Officer, before award, of the receipt of any communication from the Administrator, or a designee, of the Environmental Protection Agency, indicating that any facility that the bidder proposes to use for the performance of the contract is under consideration to be listed on the EPA List of Violating Facilities; and,

(c) The bidder will include a certification substantially the same as this certification, including this paragraph (c), in every nonexempt subcontract.

12. Previous Participation Certificate (applicable to construction and equipment contracts exceeding \$50,000)

(a) The bidder shall complete and submit with his/her bid the Form HUD-2530, "Previous Participation Certificate." If the successful bidder does not submit the certificate with his/her bid, he/she must submit it within three (3) working days of bid opening. Failure to submit the certificate by that date may render the bid nonresponsive. No contract award will be made without a properly executed certificate.

(b) A fully executed "Previous Participation Certificate" [] is, [] is not included with the bid.

13. Bidder's Signature

The bidder hereby certifies that the information contained in these certifications and representations is accurate, complete, and current.

(Signature and Date)

(Typed or Printed Name)

(Title)

(Company Name)

(Company Address)

Oakland Housing Authority Economic
Opportunities Policy – Section 3 Requirements



EXHIBIT B

OHA ECONOMIC OPPORTUNITIES POLICY

Oakland Housing Authority Economic Opportunities Policy

Background:

Section 3 of the Housing and Urban Development Act of 1968, as amended, 12 U.S.C, 1701U (hereinafter referred to as "Section 3") requires that economic opportunities generated by certain U.S. Department of Housing and Urban Development financial assistance for housing and community development programs shall, to the greatest extent feasible, be given to low - and very low-income persons, particularly those who are recipients of government assistance for housing, and to businesses that provide economic opportunities for these persons.

The U.S. Department of Housing and Urban Development's regulations implementing Section 3 are found at 24 CFR Part 135. It is the intent of OHA policy to comply fully with Section 3; and by publication of this policy, the OHA provides direction for application of this policy.

This policy shall remain in effect for all covered activities so long as this policy remains consistent with federal regulations or until changed by the Authority. . In any case where it is found that any provision of this policy or of a procedure or program undertaken in furtherance of this policy is found to be inconsistent with Section 3 or 24 CFR Part 135, Section 3 or 24 CFR Part 135 shall prevail.

Policy Statement:

It is the policy of the Oakland Housing Authority to provide to the greatest extent feasible economic opportunities to low- and very low-income persons residing in Oakland metropolitan area (as defined in § 135.5 of 24 CFR Part 135 and to businesses meeting the definition of "Section 3 business concern" as defined by 24 CFR Part 135.

A Section 3 resident is :

- A Public housing residents and/or
- An individual who live in the area where a HUD-assisted project is located and who is either low-or very-low income persons as determined by HUD
- **Determining Income Levels:**
- Low income is defined as 80% or below the median income of that area.
- Very low income is defined as 50% or below the median income of that area.

(Income Limits are subject to change. Current Income Limits may be accessed on the OHA website at www.oakha.org.)

Section 3 business concern is a business that:

- Is 51 percent or more owned by Section 3 residents;
- Whose permanent, full-time employees include persons, at least 30% of whom are currently section 3 residents, or within three years of the date of first employment with the business concern were section 3 residents; or
- Provides evidence of a commitment to subcontract to Section 3 business concerns, 25 percent or more of the dollar amount of the awarded contract.

In furtherance of this policy the Oakland Housing Authority shall develop programs and procedures necessary to implement this policy covering all procurement contracts where labor and/or professional services are provided, in order to achieve the goals outlined below. This policy does not apply to routine maintenance, repair or replacement work using HUD housing and community development assistance for housing rehabilitation; nor does it apply to contractors who only furnish materials or supplies

through OHA's procurement program, and do not undertake work, as in the installation of the material or equipment. All covered contracts executed after the adoption of this policy must comply with this policy.

Goals:

All contractors undertaking Section 3 covered projects and Section 3 covered activities on behalf of the Oakland Housing Authority are expected to meet the requirements of Section 3. Any contractor (whether or not it meets the definition of a Section 3 business), shall demonstrate compliance with the "greatest extent feasible" requirement of Section 3, must meet the numerical goals set forth below for providing training, employment and contracting opportunities to Section 3 residents and Section 3 business concerns. In meeting the goals, contractors are to apply a system of priority selection from among those Section 3 residents eligible pursuant to § 135.34, 24 CFR Part 135:

First priority - residents of the development where the work is to be performed.

Second priority - other residents of Oakland Housing Authority properties.

Third priority - other residents of Oakland who are participants of HUD Youth build programs being carried out in the City of Oakland.

Fourth priority - other persons from the Oakland metropolitan area who meet the definition of Section 3 resident contained in § 135.5 of 24 CFR Part 135.

Furthermore, for all construction contracts in excess of \$100,000, contractors and their subcontractors are required to utilize appropriate State-approved apprenticeship programs that have graduated apprentices as a means to meet the Section 3 employment goals.

Employment:

All contractors will seek the greatest extent feasible to achieve a level of 30% of all new hires to be low to very low-income residents of the Oakland metropolitan area.

Preference for Section 3 business concerns:

It is OHA's policy to conduct all procurement transactions in a competitive manner. Within this framework, preference shall be awarded to Section 3 business concerns according to the following system:

Small Purchases:

For Section 3 covered contracts aggregating no more than \$100,000, the Authority shall follow its small purchase procedures as outlined in its procurement policy. *Small Purchases require at least 3 competitive quotes. Purchases under \$2,000 (also known as Micro Purchases) do not require competitive quotes.*

Competitive (Sealed) Bids (IFBs): (IFB=Invitation For Bids)

Where the Section 3 covered contract is to be awarded based upon the lowest price, the contract shall be awarded to the qualified Section 3 business concern with the lowest responsive quotation, if it is reasonable and no more than 10 percent higher than the quotation of the lowest responsive quotation from any qualified source. If no responsive quotation by a qualified Section 3 business concern is within 10 percent of the lowest responsive quotation from any qualified source, the award shall be made to the source with the lowest quotation.

1. Bids shall be solicited from all businesses (Section 3 business concerns and non Section 3 business concerns). An award shall be made to the qualified Section 3 business concern with the highest priority ranking (as defined in 24 CFR Part 135) and with the lowest responsive bid if that bid:
 - A. is within the maximum total contract price established in the Authority's budget for the specific project for which bids are being taken; and
 - B. is not more than "X" higher than the total bid price of the lowest responsive bid from any responsible bidder. "X" is determined as follows:

<p><u>X = lesser of:</u></p>
<p>When the lowest responsive bid is less than \$100,00010% of that bid or \$9,000</p> <p>When the lowest responsive bid is:</p> <p style="padding-left: 40px;">At least \$100,000, but less than \$200,0009% of that bid or \$16,000</p> <p style="padding-left: 40px;">At least \$200,000, but less than \$300,0008% of that bid or \$21,000</p> <p style="padding-left: 40px;">At least \$300,000, but less than \$400,0007% of that bid or \$24,000</p> <p style="padding-left: 40px;">At least \$400,000, but less than \$500,0006% of that bid or \$25,000</p> <p style="padding-left: 40px;">At least \$500,000, but less than \$1 million . . .5% of that bid or \$40,000</p> <p style="padding-left: 40px;">At least \$1 million, but less than \$2 million . .4% of that bid or \$60,000</p> <p style="padding-left: 40px;">At least \$2 million, but less than \$4 million . .3% of that bid or \$80,000</p> <p style="padding-left: 40px;">At least \$4 million, but less than \$7 million . .2% of that bid or \$105,000</p> <p style="padding-left: 40px;">\$7 million or more1 1/2% of the lowest responsive bid, with no dollar limit.</p>

2. If no responsive bid by a Section 3 business concern meets the requirements of paragraph 1 of this section, the contract shall be awarded to a responsible bidder with the lowest responsive bid.
3. In both paragraph 1 and 2 above, a bidder, to be considered as responsible, must demonstrate compliance with the "greatest extent feasible" requirement of Section 3.

Competitive Proposals (RFP) (RFP=Request For Proposals)

Where the Section 3 covered contract is to be awarded based on factors other than price, a request for quotations shall be issued by developing the particulars of the solicitation, including a rating system for the assignment of points to evaluate the merits of each quotation. The solicitation shall identify all factors to be considered, including price or cost. In accordance to 24CFR135, the rating system shall provide for a range of 15 to 25 percent of the total number of available rating points to be set aside for the provision of preference for section 3 business concerns. The purchase order shall be awarded to the responsible firm whose quotation is the most advantageous, considering price and all other factors specified in the rating systems. Proposals from firms not demonstrating compliance with the "greatest extent feasible" requirement of Section 3 shall not be considered responsible.

In accordance to 24 CFR Part 135.36, Appendix Section III(3)ii:

“(3) Procurement under the competitive proposals method of procurement (Request for Proposals (RFP)).

- (i) *For contracts and subcontracts awarded under the competitive proposals method of procurement (24 CFR 85.36(d)(3)), a Request for Proposals (RFP) shall identify all evaluation factors (and their relative importance) to be used to rate proposals.*
- (ii) *(ii) One of the evaluation factors shall address both the preference for section 3 business concerns and the acceptability of the strategy for meeting the greatest extent feasible requirement (section 3 strategy), as disclosed in proposals submitted by all business concerns (section 3 and non-section 3 business concerns). This factor shall provide for a range of 15 to 25 percent of the total number of available points to be set aside for the evaluation of these two components.”*
- (iii) *With regard to the section 3 strategy, the RFP shall require the disclosure of the contractor’s section 3 strategy to comply with the Section 3 training and employment*

preference, or contracting preference, or both, if applicable. A determination of the contractor's responsibility will include the submission of an acceptable section 3 strategy. The contract award shall be made to the responsible firm (either section 3 or non-section 3) whose proposal is determined most advantageous, considering price and all other factors specified in the RFP.

Other Provisions:

1. Federal labor standards requirements: Certain construction contracts are subject to compliance with the requirement to pay prevailing wages determined under Davis-Bacon Act (40 U.S.C. 276a--276a-7) and implementing U.S. Department of Labor regulations in 29 CFR part 5. Additionally, certain HUD-assisted rehabilitation and maintenance activities on public and Indian housing developments are subject to compliance with the requirement to pay prevailing wage rates, as determined or adopted by HUD, to laborers and mechanics employed in this work. Apprentices and trainees may be utilized on this work only to the extent permitted under either Department of Labor regulations at 29 CFR part 5 or for work subject to HUD-determined prevailing wage rates, HUD policies and guidelines.
2. A section 3 business concern seeking a contract or a subcontract must submit evidence to the recipient, contractor, or subcontractor (as applicable), if requested, sufficient to demonstrate to the satisfaction of the party awarding the contract that the business concern is responsible and has the ability to perform successfully under the terms and conditions of the proposed contract.
3. OHA will ensure compliance with section 3 requirements through efforts that may include the following:
 - A. Requiring that contractors submit relevant documentation certifying their eligibility for preference under the section 3 program, and/or demonstrating their compliance with section 3 requirements.
 - B. Conducting ongoing section 3 compliance review of applicable contractors and take appropriate action when they are found to be noncompliant with section 3 requirements.
 - C. Refraining from entering into a contract with any contractor after notification by HUD that the contractor has been found in violation of section 3 regulations.
 - D. Implementing procedures designed to notify section 3 residents about training and employment opportunities generated by section 3 covered assistance and section 3 business concerns about contracting opportunities generated by section 3 covered assistance;
 - E. Notifying potential contractors for section 3 covered projects of the requirements of this part.
4. All OHA section 3 covered contracts shall include the following clause set forth in 24 CFR 135.38:
 - A. The work to be performed under this contract is subject to the

requirements of section 3 of the Housing and Urban Development Act of 1968, as amended, 12 U.S.C. 1701u (section 3). The purpose of section 3 is to ensure that employment and other economic opportunities generated by HUD assistance or HUD-assisted projects covered by section 3, shall, to the greatest extent feasible, be directed to low- and very low-income persons, particularly persons who are recipients of HUD assistance for housing.

- B. The parties to this contract agree to comply with HUD's regulations in 24 CFR part 135, which implement section 3. As evidenced by their execution of this contract, the parties to this contract certify that they are under no contractual or other impediment that would prevent them from complying with the part 135 regulations.
- C. The contractor agrees to send to each labor organization or representative of workers with which the contractor has a collective bargaining agreement or other understanding, if any, a notice advising the labor organization or workers' representative of the contractor's commitments under this section 3 clause, and will post copies of the notice in conspicuous places at the work site where both employees and for training and employment positions can see the notice. The notice shall describe the section 3 preference, shall set forth minimum number and job titles subject to hire, availability of apprenticeship and training positions, the qualifications for each; and the name and location of the person(s) taking applications for each of the positions; and the anticipated date the work shall begin.
- D. The contractor agrees to include this section 3 clause in every subcontract subject to compliance with regulations in 24 CFR part 135, and agrees to take appropriate action, as provided in an applicable provision of the subcontract or in this section 3 clause, upon a finding that the subcontractor is in violation of the regulations in 24 CFR part 135. The contractor will not subcontract with any subcontractor where the contractor has notice or knowledge that the subcontractor has been found in violation of the regulations in 24 CFR part 135.
- E. The contractor will certify that any vacant employment positions, including training positions, that are filled (1) after the contractor is selected but before the contract is executed, and (2) with persons other than those to whom the regulations of 24 CFR part 135 require employment opportunities to be directed, were not filled to circumvent the contractor's obligations under 24 CFR part 135.
- F. Noncompliance with HUD's regulations in 24 CFR part 135 may result in sanctions, termination of this contract for default, and debarment or suspension from future HUD assisted contracts.

Definitions:

The Oakland Housing Authority incorporates into this policy the definitions contained in § 135.5 of 24 CFR Part 135 Further, the Oakland Housing Authority makes no representation concerning

interpretation and meaning of Section 3 of the Housing Act of 1968, as amended, and of 24 CFR Part 135 beyond this policy. It is recommended that interest parties refer directly to the law and regulations for a complete understanding of their meaning.

Contractor's Summary Guide to Section 3 Compliance



Oakland Housing
Authority

Contractor's Summary Guide to Section 3 Compliance

The purpose of Section 3 of the Housing and Urban Development Act of 1968 as amended (12 U.S.C. 1701u) (section 3), and 24 CFR Part 135, is to ensure that training, employment and other economic opportunities generated by certain HUD financial assistance shall, to the greatest extent feasible, and consistent with existing federal, state and local laws and regulations, be directed to low- and very low-income persons, particularly those who are recipients of government assistance for housing, and to business concerns, which provide economic opportunities to low- and very low-income persons.” **For the complete text of the Section 3 regulations, visit www.hud.gov/section3.**

Oakland Housing Authority's Section 3 Economic Opportunities Policy (included in bid documents)

Oakland has one of the highest unemployment rates in the Bay Area. Oakland Housing Authority (OHA) residents make up over 10% of Oakland's population. OHA developed its **Economic Opportunities Policy** (EOP) to comply with the Housing and Urban Development (HUD) Section 3 regulations and ensure that, to the greatest extent feasible, economic opportunities are provided to low- and very low-income persons and to Section 3 business concerns within the city of Oakland. All contractors undertaking Section 3 covered projects and activities on behalf of OHA are expected, to the greatest extent feasible, to meet the numerical goals set forth below. The policy does not apply to contractors who furnish only materials or supplies and do not undertake installation of materials or supplies. The **EOP** is also available from OHA's website www.oakha.org/procurement/sec3EcoOpportPolicy.pdf.

Section 3 Requirement for All Bidders

As part of the application or bidding process, a Section 3 Business Preference and Action Plan are included in bid documents. Contractors have the option to request Certification as a Section 3 business; however, every proposer **MUST** complete the Action Plan and submit it with their bid, even if no hires are projected.

Certification for Business Seeking Section 3 Business Preference form: Everyone must complete the top portion (check one box, name of business etc.) and sign at the bottom. Fill in the other parts **ONLY** if you are claiming Section 3 business status.

Action Plan (3 pages): Everyone must complete the top portion listing your company etc., where applicable, and sign every page. If you **do not** anticipate new hires, note that in the table on page 1 and 3. If you **do** anticipate new hires, then use page 1 to detail the job categories and page 3 to describe how you will fill those positions.

Section 3 Requirements for Awardees

Baseline Reporting and Hiring Projections Form

Prior to the Notice to Proceed, the contractor/subcontractor will be responsible for documenting the current workforce (baseline) and providing more accurate hiring projections per job classification than those described in the Action Plan. The Plan that is approved will become part of the contractual agreements.

Hiring Goals

The Section 3 requirement is triggered when there is a need for **new** economic opportunities, such as individual employment, contracting, or subcontracting. The regulation requires that contractors and subcontractors provide, **to the greatest extent feasible**, economic opportunities (training, employment, and contracting) to low and very-low income residents Section 3 businesses.

Contractors and subcontractors are required to make every effort to the greatest extent feasible to meet the OHA's numerical hiring goals of having Section 3 qualified employees make up **30% of their total new-hires**. **Firms must seek to maintain this percentage throughout the life of the project.** If these goals are not met, the contractors are expected to show documentation demonstrating their efforts to hire Section 3 candidates by exhausting all available hiring sources. While a contractor receives credit for hiring low-income residents of Oakland, **first priority should be given to residents of the Oakland Housing Authority**. This includes residents in both the public housing and Section 8 programs.

Hiring Priorities

First priority (OHA residents): Residents of the development where the work is being performed
Second priority (OHA residents): Other residents of Oakland Housing Authority owned or managed properties
Third priority (Oakland residents): Other residents within the city of Oakland that meet the low-income requirements (see definition of **Section 3 Resident** below).

Resident Referral Process

OHA is committed to working with general contractors and subcontractors to help them reach their Section 3 goals. Therefore, we have established a pre-screening and referral process to identify qualified OHA residents who satisfy the first and second hiring priorities (above). This process ensures that each candidate is in good standing with the housing authority and has a background that qualifies him/her to perform the essential functions of the job.

To ensure the best possible match, it is important that contractors communicate their hiring needs to OHA well in advance of the project start date. We request at least 2 business days' notice before the employee's start date, but earlier notice is preferred. We will work with you to identify a pool of candidates for each position. If we cannot provide you with a candidate, we will grant you a waiver to document your efforts to meet the Section 3 goals.

Union Contractors: OHA's Family and Community Partnerships department (FCP) has established a list of current OHA residents in construction trade unions that is sent to contractors on a regular basis. If there is no candidate that meets your hiring needs, you are encouraged to consider sponsoring an OHA resident who is not a member of a trade union to meet your Section 3 hiring goals.

Please contact OHA at S3hire@oakha.org or 510-587-5160 for a list of qualified residents, to request a candidate, or verify the Section 3 eligibility of any prospective hire. For more information about providing economic opportunities to OHA resident's contact:

Employment Development Coordinator
Family & Community Partnerships Department
Phone: 510.587.5160
Fax: 510.587.5141
Email: S3hire@oakha.org

New Hire Section 3 Information Form

General contractors and subcontractors will be provided this form upon award. Every **new hire** should be requested to complete the form. The form provides the means to determine Section 3 eligibility of the employee. The forms should be submitted to OHA as soon as possible after hiring for verification of Section 3 status.

Monthly Reports

OHA requires monthly reports listing all new hires and Section 3 hires from all contractors and subcontractors on Section 3 covered projects. A sample report will be provided. Reports shall be due on the fifth day of each month for the preceding month. These reports shall be submitted to:

Rufus Davis, Labor and Section 3 Compliance Officer
Office of Program Administration
Phone: 510.587.7131
Fax: 510.587.2124
Email: rdavis@oakha.org

Record Maintenance and Documentation

All projects and activities that are subject to Section 3 requirements shall maintain comprehensive documentation of their Section 3 outreach efforts and implementation activities. Section 3 documentation files should be clearly maintained and be available for review by Oakland Housing Authority and/or HUD officials.

Compliance Reviews

OHA staff will conduct regular compliance reviews, which consist of comprehensive analysis and evaluation of the contractor's compliance with Section 3. Where noncompliance is found, OHA will notify the contractor of the deficiency and make recommendations for corrective actions.

Useful Definitions

Business Concern

A business entity formed in accordance with state law, and which is licensed under state, county or municipal law to engage in the type of business activity for which it was formed.

“Greatest Extent Feasible”

Recipients of Section 3 financial assistance must make every effort within their disposal to meet the regulatory requirements. For instance, this may mean going a step beyond normal notification procedures for employment and contracting opportunities by developing strategies that will specifically target Section 3 residents and businesses for these new economic opportunities.

Household Income Levels

Low and very-low income limits are determined annually by HUD. These limits are typically established at 80 percent and 50 percent of the median income for each locality by household size or number of people residing in one house. HUD income limits can be obtained from www.huduser.org/portal/datasets/il.html.

New Hire

A new hire means a full-time employee for a new permanent, temporary, or seasonal position that is created as a direct result of the expenditure of federal funds on Section 3 covered projects. Any employee that is not on the payroll of a contractor or developer on the day [i.e., that a purchase order is issued or the day a contract is signed or agreed upon] that the Section 3 covered assistance was provided, is considered a new hire.

Section 3 Business Concern

A business concern that meets one or more of the following requirements:

- 51% or more owned by Section 3 residents
- 30% or more of permanent, full-time workforce consists of Section 3 residents
- Provides evidence to subcontract at least 25% of the dollar awarded to qualified Section 3 businesses

Section 3 Resident

- (1) An Oakland Housing Authority public housing resident or Section 8 voucher holder; or
- (2) An individual who resides in the service area (Oakland) in which the Section 3 covered assistance is expended, and whose income status is as follows:

Number of People in Household	Annual Household Income Limits (Source: 24 CFR 570.3)
1	\$47,500 or less
2	\$53,950 or less
3	\$60,400 or less
4	\$66,800 or less
5	\$72,000 or less
6	\$77,150 or less
7	\$82,300 or less
8	\$87,450 or less

(Income limits eff. 01/02/2015)

Questions regarding the Oakland Housing Authority
Section 3 Program should be addressed to:

Rufus Davis, Labor and Section 3 Compliance Officer
Oakland Housing Authority
1801 Harrison Street
Oakland, CA 94612
Phone: 510.587.2176
Fax: 510.587.2124
Email: rdavis@oakha.org



Section 3 Business Certification and Action Plan

Section 3 Business Certification – 1 page

Check this box if you are **not** claiming Section 3 business status. Complete Section 1 and the signature block at the bottom of this page and proceed to the **Section 3 Action Plan**.

SECTION 1

Company Name _____

Address _____

Type of Business (Check One): Corporation Partnership Sole Proprietorship Other

Project (Bid/RFP #) _____ Business Activity _____

SECTION 2

Current Section 3 Status: The undersigned bidder/proposer hereby certifies that it is a Section 3 business concern and attaches relevant documentation, **as applicable**, to support such claim.

Select only one option.

1. A business claiming status as a Section 3 resident-owned business concern (ROB):

Initial here to select this option _____

- | | |
|---|--|
| <input type="checkbox"/> OHA resident lease | <input type="checkbox"/> List of owners/stockholders and % of each |
| <input type="checkbox"/> Copy of receipt of public assistance | <input type="checkbox"/> Latest board minutes appointing officers |
| <input type="checkbox"/> Other evidence of income status | <input type="checkbox"/> Articles of incorporation |
| <input type="checkbox"/> Fictitious or Assumed Business Name Certificate | <input type="checkbox"/> Partnership agreement |
| <input type="checkbox"/> Organization chart with names and titles and brief job description | |

2. A business claiming Section 3 status because at least 30% of its permanent full-time employees are currently Section 3 residents or, within 3 years of the date of first employment with the business concern, were Section 3 residents. If a business claims this option, the 30% employment requirement must be maintained for the entire project. **Initial here to select this option** _____

- | | |
|--|---|
| <input type="checkbox"/> List of all current full time employees | <input type="checkbox"/> List of all employees claiming Section 3 status |
| <input type="checkbox"/> OHA residential lease (less than 3 years from date of employment) | <input type="checkbox"/> Other evidence of Section 3 status (less than 3 years from date of employment) |

3. A business claiming Section 3 status by subcontracting 25% or more of the dollar award to qualified Section 3 businesses (as set forth in Options 1 and 2). **Initial here to select this option** _____

- Provide a list of intended Section 3 business subcontractors with subcontract amount.
- Include this Section 3 Certification form and all supporting documentation for each planned Section 3 business subcontractor.

If you are or become certified as a Section 3 business, do you grant OHA permission to share your business contact information with firms seeking to contract with Section 3 businesses? Yes No

I attest that the above information is true and correct.

Signature

Printed Name

Title

Date



Section 3 Action Plan (2 pages)

All firms and individuals bidding on any Section 3 covered contract with the Oakland Housing Authority (OHA) **MUST COMPLETE AND SUBMIT THIS ACTION PLAN WITH THE BID, OFFER, OR PROPOSAL.** Any solicitation response that does not include this document (completed and signed) will be considered non-responsive and not eligible for award.

PRELIMINARY STATEMENT OF CURRENT WORKFORCE AND HIRING NEEDS

THIS PLAN OUTLINES YOUR COMMITMENT TO OHA'S SECTION 3 HIRING GOALS

COMPANY NAME: _____

ADDRESS: _____

PROJECT (BID/RFP#): _____ GENERAL SUBCONTRACTOR

JOB CATEGORY: EXAMPLES ADMINISTRATIVE ASST., OFFICE MANAGER, CLERK, PROJECT MANAGER, EQUIPMENT MECHANIC, JANITORIAL, HOUSING MANAGEMENT, LABORER, LANDSCAPER, GLAZIER-JOURNEYMAN, GLAZIER-APPRENTICE, PLUMBER-JOURNEYMAN, PLUMBER-APPRENTICE	(A) # of CURRENT Employees (Core Staff)	(B) PROJECTED # of New Hires FOR THIS PROJECT	(C) PROJECTED # of Section 3 Hires	(D) PROJECTED Section 3 Hires as a Percentage of NEW HIRES
				%
				%
				%
				%
				%
				%
				%
				%
OTHER, PLEASE LIST.				%

___ (Check here and attach another sheet if applicable)

Check this box if contractor does not anticipate triggering the regulation by the need for new hiring or subcontracting opportunities. Complete the signature block at the bottom of this page.

I attest that the above information is true and correct. The company certifies that the above table represents the appropriate number of employee positions and also represents the number of Section 3 employees that the company proposes to hire.

Signature

Printed Name

Section 3 Action Plan (continued)

EFFORTS TO ACHIEVE SECTION 3 COMPLIANCE

Indicate the efforts your organization will take to direct employment and other economic opportunities, to the greatest extent feasible, to low-income residents. Think about how you can leverage your resources and expertise to foster training and employment opportunities for Section 3 residents. **Examples** include, but are not limited to, the following. Check all that apply.

- Refer to any list of pre-screened job-ready applicants provided by OHA's Department of Family and Community Partnerships (FCP) (*REQUEST A LIST from FCP at S3hire@oakha.org or 510-587-5160*).
- Utilize and manage union privileges such as name-call, transfer, rehire, and sponsorship.
- Financially sponsor OHA resident(s) in trainings, certifications, professional mentorships, etc.
- Distribute flyers door-to-door to OHA owned and managed properties.
- Run multiple advertisements in local media such as newspapers and radio stations, and/or Internet-based job-posting websites announcing the hiring and contracting opportunities.
- Contract with certified Section 3 businesses, in construction and non-construction trades (*REQUEST A LIST from Rufus Davis at OHA, rdavis@oakha.org or 510-587-2176*).
- Post signs at the entrance to the job site stating that it is a Section 3 covered project.
- Sponsor (schedule, advertise, finance, or provide in-kind services) a job informational meeting to be conducted by the housing authority or a contractor representative.
- Undertake job counseling, education and related programs in association with local educational institutions.
- Other: _____

I attest that the above information is true and correct.

Signature

Printed Name

Title

Date

SECTION 3 CLAUSE (24 CFR 135.38)

This contract is subject to the following conditions under Section 3 of the Housing and Urban Development Act of 1968, as amended, 12 U.S.C. 1701u (Section 3).

- A. The work to be performed under this contract is subject to the requirements of Section 3 of the Housing and Urban Development Act of 1968, as amended, 12 U.S.C. 1701u (Section 3). The purpose of Section 3 is to ensure that employment and other economic opportunities generated by HUD assistance or HUD-assisted projects covered by Section 3, shall, to the greatest extent feasible, be directed to low and very low-income persons, particularly persons who are recipients of HUD assistance for housing.
- B. The parties to this contract agree to comply with HUD's regulations in 24 CFR Part 135, which implement Section 3. As evidenced by their execution of this contract, the parties to this contract certify that they are under no contractual or other impediment that would prevent them from complying with the Part 135 regulations.
- C. The contractor agrees to send to each labor organization or representative of workers with which the contractor has a collective bargaining agreement or other understanding, if any, a notice advising the labor or organization or workers' representative of the contractor's commitments under this Section 3 clause, and will post copies of the notice in conspicuous places at the work site where both employees and applicants for training and employment positions can see the notice. The notice shall describe the Section 3 preference, shall set forth minimum number and job titles subject to hire, availability of apprenticeship and training positions, the qualifications for each; and the name and location of the person(s) taking applications for each of the positions; and the anticipated date the work shall begin.
- D. The contractor agrees to include this Section 3 clause in every subcontract subject to compliance with regulations in 24 CFR Part 135, and agrees to take appropriate action, as provided in an applicable provision of the subcontract or in this Section 3 clause, upon finding that the subcontractor is in violation of the regulations in 24 CFR Part 135. The contractor will not subcontract with any subcontractor where the contractor has notice or knowledge that the subcontractor has been found in violation of the regulations in 24 CFR Part 135.
- E. The contractor will certify that any vacant employment positions, including training positions that are filled (1) after the contractor is selected but before the contract is executed, and (2) with persons other than those to whom the regulations of 24 CFR Part 135 require employment opportunities to be directed, were not filled to circumvent the contractor's obligations under 24 CFR Part 135.
- F. Noncompliance with HUD's regulations in 24 CFR Part 135 may result in sanctions, termination of this contract for default, and debarment or suspension from future HUD assisted contracts.
- G. With respect to work performed in connection with Section 3 covered Indian housing assistance, Section 7(b) of the Indian Self-Determination and Education Assistance Act (25 U.S.C. 450e) also applies to the work to be performed under this contract. Section 7(b) requires that to the greatest extent feasible (preference and opportunities for training and employment shall be given to Indians, and (ii) preference in the award of contracts and subcontracts shall be given to Indian organizations and Indian-owned Economic Enterprise. Parties to this contract that are subject to the provisions of Section 3 and Section 7(b) agree to comply with Section 3 to the maximum extent feasible, but not in derogation of compliance with Section 7(b).

U.S. Department of Housing and Urban Development
– Instructions to bidders for Contracts – Public and
Indian Housing Projects (**Form HUD-5369**)

**U.S. Department of Housing and
Urban Development**
Office of Public and Indian Housing

**Instructions to Bidders for Contracts
Public and Indian Housing Programs**

Instructions to Bidders for Contracts

Public and Indian Housing Programs

Table of Contents

Clause	Page
1. Bid Preparation and Submission	1
2. Explanations and Interpretations to Prospective Bidders	1
3. Amendments to Invitations for Bids	1
4. Responsibility of Prospective Contractor	1
5. Late Submissions, Modifications, and Withdrawal of Bids	1
6. Bid Opening	2
7. Service of Protest	2
8. Contract Award	2
9. Bid Guarantee	3
10. Assurance of Completion	3
11. Preconstruction Conference	3
12. Indian Preference Requirements	3

1. Bid Preparation and Submission

(a) Bidders are expected to examine the specifications, drawings, all instructions, and, if applicable, the construction site (see also the contract clause entitled **Site Investigation and Conditions Affecting the Work** of the *General Conditions of the Contract for Construction*). Failure to do so will be at the bidders' risk.

(b) All bids must be submitted on the forms provided by the Public Housing Agency/Indian Housing Authority (PHA/IHA). Bidders shall furnish all the information required by the solicitation. Bids must be signed and the bidder's name typed or printed on the bid sheet and each continuation sheet which requires the entry of information by the bidder. Erasures or other changes must be initialed by the person signing the bid. Bids signed by an agent shall be accompanied by evidence of that agent's authority. (Bidders should retain a copy of their bid for their records.)

(c) Bidders must submit as part of their bid a completed form HUD-5369-A, "Representations, Certifications, and Other Statements of Bidders."

(d) All bid documents shall be sealed in an envelope which shall be clearly marked with the words "Bid Documents," the Invitation for Bids (IFB) number, any project or other identifying number, the bidder's name, and the date and time for receipt of bids.

(e) If this solicitation requires bidding on all items, failure to do so will disqualify the bid. If bidding on all items is not required, bidders should insert the words "No Bid" in the space provided for any item on which no price is submitted.

(f) Unless expressly authorized elsewhere in this solicitation, alternate bids will not be considered.

(g) Unless expressly authorized elsewhere in this solicitation, bids submitted by telegraph or facsimile (fax) machines will not be considered.

(h) If the proposed contract is for a Mutual Help project (as described in 24 CFR Part 905, Subpart E) that involves Mutual Help contributions of work, material, or equipment, supplemental information regarding the bid advertisement is provided as an attachment to this solicitation.

2. Explanations and Interpretations to Prospective Bidders

(a) Any prospective bidder desiring an explanation or interpretation of the solicitation, specifications, drawings, etc., must request it at least 7 days before the scheduled time for bid opening. Requests may be oral or written. Oral requests must be confirmed in writing. The only oral clarifications that will be provided will be those clearly related to solicitation procedures, i.e., not substantive technical information. No other oral explanation or interpretation will be provided. Any information given a prospective bidder concerning this solicitation will be furnished promptly to all other prospective bidders as a written amendment to the solicitation, if that information is necessary in submitting bids, or if the lack of it would be prejudicial to other prospective bidders.

(b) Any information obtained by, or provided to, a bidder other than by formal amendment to the solicitation shall not constitute a change to the solicitation.

3. Amendments to Invitations for Bids

(a) If this solicitation is amended, then all terms and conditions which are not modified remain unchanged.

(b) Bidders shall acknowledge receipt of any amendment to this solicitation (1) by signing and returning the amendment, (2) by identifying the amendment number and date on the bid form, or (3) by letter, telegram, or facsimile, if those methods are authorized in the solicitation. The PHA/IHA must receive acknowledgement by the time and at the place specified for receipt of bids. Bids which fail to acknowledge the bidder's receipt of any amendment will result in the rejection of the bid if the amendment(s) contained information which substantively changed the PHA's/IHA's requirements.

(c) Amendments will be on file in the offices of the PHA/IHA and the Architect at least 7 days before bid opening.

4. Responsibility of Prospective Contractor

(a) The PHA/IHA will award contracts only to responsible prospective contractors who have the ability to perform successfully under the terms and conditions of the proposed contract. In determining the responsibility of a bidder, the PHA/IHA will consider such matters as the bidder's:

- (1) Integrity;
- (2) Compliance with public policy;
- (3) Record of past performance; and
- (4) Financial and technical resources (including construction and technical equipment).

(b) Before a bid is considered for award, the bidder may be requested by the PHA/IHA to submit a statement or other documentation regarding any of the items in paragraph (a) above. Failure by the bidder to provide such additional information shall render the bidder nonresponsible and ineligible for award.

5. Late Submissions, Modifications, and Withdrawal of Bids

(a) Any bid received at the place designated in the solicitation after the exact time specified for receipt will not be considered unless it is received before award is made and it:

(1) Was sent by registered or certified mail not later than the fifth calendar day before the date specified for receipt of offers (e.g., an offer submitted in response to a solicitation requiring receipt of offers by the 20th of the month must have been mailed by the 15th);

(2) Was sent by mail, or if authorized by the solicitation, was sent by telegram or via facsimile, and it is determined by the PHA/IHA that the late receipt was due solely to mishandling by the PHA/IHA after receipt at the PHA/IHA; or

(3) Was sent by U.S. Postal Service Express Mail Next Day Service - Post Office to Addressee, not later than 5:00 p.m. at the place of mailing two working days prior to the date specified for receipt of proposals. The term "working days" excludes weekends and observed holidays.

(b) Any modification or withdrawal of a bid is subject to the same conditions as in paragraph (a) of this provision.

(c) The only acceptable evidence to establish the date of mailing of a late bid, modification, or withdrawal sent either by registered or certified mail is the U.S. or Canadian Postal Service postmark both on the envelope or wrapper and on the original receipt from the U.S. or Canadian Postal Service. Both postmarks must show a legible date or the bid, modification, or withdrawal shall be processed as if mailed late. "Postmark" means a printed, stamped, or otherwise placed impression (exclusive of a postage meter machine impression) that is readily identifiable without further action as having been supplied and affixed by employees of the U.S. or Canadian Postal Service on the date of mailing. Therefore, bidders should request the postal clerk to place a hand cancellation bull's-eye postmark on both the receipt and the envelope or wrapper.

(d) The only acceptable evidence to establish the time of receipt at the PHA/IHA is the time/date stamp of PHA/IHA on the proposal wrapper or other documentary evidence of receipt maintained by the PHA/IHA.

(e) The only acceptable evidence to establish the date of mailing of a late bid, modification, or withdrawal sent by Express Mail Next Day Service-Post Office to Addressee is the date entered by the post office receiving clerk on the "Express Mail Next Day Service-Post Office to Addressee" label and the postmark on both the envelope or wrapper and on the original receipt from the U.S. Postal Service. "Postmark" has the same meaning as defined in paragraph (c) of this provision, excluding postmarks of the Canadian Postal Service. Therefore, bidders should request the postal clerk to place a legible hand cancellation bull's eye postmark on both the receipt and Failure by a bidder to acknowledge receipt of the envelope or wrapper.

(f) Notwithstanding paragraph (a) of this provision, a late modification of an otherwise successful bid that makes its terms more favorable to the PHA/IHA will be considered at any time it is received and may be accepted.

(g) Bids may be withdrawn by written notice, or if authorized by this solicitation, by telegram (including mailgram) or facsimile machine transmission received at any time before the exact time set for opening of bids; provided that written confirmation of telegraphic or facsimile withdrawals over the signature of the bidder is mailed and postmarked prior to the specified bid opening time. A bid may be withdrawn in person by a bidder or its authorized representative if, before the exact time set for opening of bids, the identity of the person requesting withdrawal is established and the person signs a receipt for the bid.

6. Bid Opening

All bids received by the date and time of receipt specified in the solicitation will be publicly opened and read. The time and place of opening will be as specified in the solicitation. Bidders and other interested persons may be present.

7. Service of Protest

(a) Definitions. As used in this provision:

"Interested party" means an actual or prospective bidder whose direct economic interest would be affected by the award of the contract.

"Protest" means a written objection by an interested party to this solicitation or to a proposed or actual award of a contract pursuant to this solicitation.

(b) Protests shall be served on the Contracting Officer by obtaining written and dated acknowledgement from —

[Contracting Officer designate the official or location where a protest may be served on the Contracting Officer]

(c) All protests shall be resolved in accordance with the PHA's/IHA's protest policy and procedures, copies of which are maintained at the PHA/IHA.

8. Contract Award

(a) The PHA/IHA will evaluate bids in response to this solicitation without discussions and will award a contract to the responsible bidder whose bid, conforming to the solicitation, will be most advantageous to the PHA/IHA considering only price and any price-related factors specified in the solicitation.

(b) If the apparent low bid received in response to this solicitation exceeds the PHA's/IHA's available funding for the proposed contract work, the PHA/IHA may either accept separately priced items (see 8(e) below) or use the following procedure to determine contract award. The PHA/IHA shall apply in turn to each bid (proceeding in order from the apparent low bid to the high bid) each of the separately priced bid deductible items, if any, in their priority order set forth in this solicitation. If upon the application of the first deductible item to all initial bids, a new low bid is within the PHA's/IHA's available funding, then award shall be made to that bidder. If no bid is within the available funding amount, then the PHA/IHA shall apply the second deductible item. The PHA/IHA shall continue this process until an evaluated low bid, if any, is within the PHA's/IHA's available funding. If upon the application of all deductibles, no bid is within the PHA's/IHA's available funding, or if the solicitation does not request separately priced deductibles, the PHA/IHA shall follow its written policy and procedures in making any award under this solicitation.

(c) In the case of tie low bids, award shall be made in accordance with the PHA's/IHA's written policy and procedures.

(d) The PHA/IHA may reject any and all bids, accept other than the lowest bid (e.g., the apparent low bid is unreasonably low), and waive informalities or minor irregularities in bids received, in accordance with the PHA's/IHA's written policy and procedures.

(e) Unless precluded elsewhere in the solicitation, the PHA/IHA may accept any item or combination of items bid.

(f) The PHA/IHA may reject any bid as nonresponsive if it is materially unbalanced as to the prices for the various items of work to be performed. A bid is materially unbalanced when it is based on prices significantly less than cost for some work and prices which are significantly overstated for other work.

(g) A written award shall be furnished to the successful bidder within the period for acceptance specified in the bid and shall result in a binding contract without further action by either party.

9. Bid Guarantee (applicable to construction and equipment contracts exceeding \$25,000)

All bids must be accompanied by a negotiable bid guarantee which shall not be less than five percent (5%) of the amount of the bid. The bid guarantee may be a certified check, bank draft, U.S. Government Bonds at par value, or a bid bond secured by a surety company acceptable to the U.S. Government and authorized to do business in the state where the work is to be performed. In the case where the work under the contract will be performed on an Indian reservation area, the bid guarantee may also be an irrevocable Letter of Credit (see provision 10, Assurance of Completion, below). Certified checks and bank drafts must be made payable to the order of the PHA/IHA. The bid guarantee shall insure the execution of the contract and the furnishing of a method of assurance of completion by the successful bidder as required by the solicitation. Failure to submit a bid guarantee with the bid shall result in the rejection of the bid. Bid guarantees submitted by unsuccessful bidders will be returned as soon as practicable after bid opening.

10. Assurance of Completion

(a) Unless otherwise provided in State law, the successful bidder shall furnish an assurance of completion prior to the execution of any contract under this solicitation. This assurance may be [Contracting Officer check applicable items] —

[] (1) a performance and payment bond in a penal sum of 100 percent of the contract price; or, as may be required or permitted by State law;

[] (2) separate performance and payment bonds, each for 50 percent or more of the contract price;

[] (3) a 20 percent cash escrow;

[] (4) a 25 percent irrevocable letter of credit; or,

[] (5) an irrevocable letter of credit for 10 percent of the total contract price with a monitoring and disbursements agreement with the IHA (applicable only to contracts awarded by an IHA under the Indian Housing Program).

(b) Bonds must be obtained from guarantee or surety companies acceptable to the U.S. Government and authorized to do business in the state where the work is to be performed. Individual sureties will not be considered. U.S. Treasury Circular Number 570, published annually in the Federal Register, lists companies approved to act as sureties on bonds securing Government contracts, the maximum underwriting limits on each contract bonded, and the States in which the company is licensed to do business. Use of companies listed in this circular is mandatory. Copies of the circular may be downloaded on the U.S. Department of Treasury website <http://www.fms.treas.gov/c570/index.html>, or ordered for a minimum fee by contacting the Government Printing Office at (202) 512-2168.

(c) Each bond shall clearly state the rate of premium and the total amount of premium charged. The current power of attorney for the person who signs for the surety company must be attached to the bond. The effective date of the power of attorney shall not precede the date of the bond. The effective date of the bond shall be on or after the execution date of the contract.

(d) Failure by the successful bidder to obtain the required assurance of completion within the time specified, or within such extended period as the PHA/IHA may grant based upon reasons determined adequate by the PHA/IHA, shall render the bidder ineligible for award. The PHA/IHA may then either award the contract to the next lowest responsible bidder or solicit new bids. The PHA/IHA may retain the ineligible bidder's bid guarantee.

11. Preconstruction Conference (applicable to construction contracts)

After award of a contract under this solicitation and prior to the start of work, the successful bidder will be required to attend a preconstruction conference with representatives of the PHA/IHA and its architect/engineer, and other interested parties convened by the PHA/IHA. The conference will serve to acquaint the participants with the general plan of the construction operation and all other requirements of the contract (e.g., Equal Employment Opportunity, Labor Standards). The PHA/IHA will provide the successful bidder with the date, time, and place of the conference.

12. Indian Preference Requirements (applicable only if this solicitation is for a contract to be performed on a project for an Indian Housing Authority)

(a) HUD has determined that the contract awarded under this solicitation is subject to the requirements of section 7(b) of the Indian Self-Determination and Education Assistance Act (25 U.S.C. 450e(b)). Section 7(b) requires that any contract or subcontract entered into for the benefit of Indians shall require that, to the greatest extent feasible

(1) Preferences and opportunities for training and employment (other than core crew positions; see paragraph (h) below) in connection with the administration of such contracts or subcontracts be given to qualified "Indians." The Act defines "Indians" to mean persons who are members of an Indian tribe and defines "Indian tribe" to mean any Indian tribe, band, nation, or other organized group or community, including any Alaska Native village or regional or village corporation as defined in or established pursuant to the Alaska Native Claims Settlement Act, which is recognized as eligible for the special programs and services provided by the United States to Indians because of their status as Indians; and,

(2) Preference in the award of contracts or subcontracts in connection with the administration of contracts be given to Indian organizations and to Indian-owned economic enterprises, as defined in section 3 of the Indian Financing Act of 1974 (25 U.S.C. 1452). That Act defines "economic enterprise" to mean any Indian-owned commercial, industrial, or business activity established or organized for the purpose of profit, except that the Indian ownership must constitute not less than 51 percent of the enterprise; "Indian organization" to mean the governing body of any Indian tribe or entity established or recognized by such governing body; "Indian" to mean any person who is a member of any tribe, band, group, pueblo, or community which is recognized by the Federal Government as eligible for services from the Bureau of Indian Affairs and any "Native" as defined in the Alaska Native Claims Settlement Act; and Indian "tribe" to mean any Indian tribe, band, group, pueblo, or community including Native villages and Native groups (including

corporations organized by Kenai, Juneau, Sitka, and Kodiak) as defined in the Alaska Native Claims Settlement Act, which is recognized by the Federal Government as eligible for services from the Bureau of Indian Affairs.

(b) (1) The successful Contractor under this solicitation shall comply with the requirements of this provision in awarding all subcontracts under the contract and in providing training and employment opportunities.

(2) A finding by the IHA that the contractor, either (i) awarded a subcontract without using the procedure required by the IHA, (ii) falsely represented that subcontracts would be awarded to Indian enterprises or organizations; or, (iii) failed to comply with the contractor's employment and training preference bid statement shall be grounds for termination of the contract or for the assessment of penalties or other remedies.

(c) If specified elsewhere in this solicitation, the IHA may restrict the solicitation to qualified Indian-owned enterprises and Indian organizations. If two or more (or a greater number as specified elsewhere in the solicitation) qualified Indian-owned enterprises or organizations submit responsive bids, award shall be made to the qualified enterprise or organization with the lowest responsive bid. If fewer than the minimum required number of qualified Indian-owned enterprises or organizations submit responsive bids, the IHA shall reject all bids and readvertise the solicitation in accordance with paragraph (d) below.

(d) If the IHA prefers not to restrict the solicitation as described in paragraph (c) above, or if after having restricted a solicitation an insufficient number of qualified Indian enterprises or organizations submit bids, the IHA may advertise for bids from non-Indian as well as Indian-owned enterprises and Indian organizations. Award shall be made to the qualified Indian enterprise or organization with the lowest responsive bid if that bid is -

(1) Within the maximum HUD-approved budget amount established for the specific project or activity for which bids are being solicited; and

(2) No more than the percentage specified in 24 CFR 905.175(c) higher than the total bid price of the lowest responsive bid from any qualified bidder. If no responsive bid by a qualified Indian-owned economic enterprise or organization is within the stated range of the total bid price of the lowest responsive bid from any qualified enterprise, award shall be made to the bidder with the lowest bid.

(e) Bidders seeking to qualify for preference in contracting or subcontracting shall submit proof of Indian ownership with their bids. Proof of Indian ownership shall include but not be limited to:

(1) Certification by a tribe or other evidence that the bidder is an Indian. The IHA shall accept the certification of a tribe that an individual is a member.

(2) Evidence such as stock ownership, structure, management, control, financing and salary or profit sharing arrangements of the enterprise.

(f) (1) All bidders must submit with their bids a statement describing how they will provide Indian preference in the award of subcontracts. The specific requirements of that statement and the factors to be used by the IHA in determining the statement's adequacy are included as an attachment to this solicitation. Any bid that fails to include the required statement shall be rejected as nonresponsive. The IHA may require that comparable statements be provided by subcontractors to the successful Contractor, and may require the Contractor to reject any bid or proposal by a subcontractor that fails to include the statement.

(2) Bidders and prospective subcontractors shall submit a certification (supported by credible evidence) to the IHA in any instance where the bidder or subcontractor believes it is infeasible to provide Indian preference in subcontracting. The acceptance or rejection by the IHA of the certification shall be final. Rejection shall disqualify the bid from further consideration.

(g) All bidders must submit with their bids a statement detailing their employment and training opportunities and their plans to provide preference to Indians in implementing the contract; and the number or percentage of Indians anticipated to be employed and trained. Comparable statements from all proposed subcontractors must be submitted. The criteria to be used by the IHA in determining the statement(s)'s adequacy are included as an attachment to this solicitation. Any bid that fails to include the required statement(s), or that includes a statement that does not meet minimum standards required by the IHA shall be rejected as nonresponsive.

(h) Core crew employees. A core crew employee is an individual who is a bona fide employee of the contractor at the time the bid is submitted; or an individual who was not employed by the bidder at the time the bid was submitted, but who is regularly employed by the bidder in a supervisory or other key skilled position when work is available. Bidders shall submit with their bids a list of all core crew employees.

(i) Preference in contracting, subcontracting, employment, and training shall apply not only on-site, on the reservation, or within the IHA's jurisdiction, but also to contracts with firms that operate outside these areas (e.g., employment in modular or manufactured housing construction facilities).

(j) Bidders should contact the IHA to determine if any additional local preference requirements are applicable to this solicitation.

(k) The IHA [] does [] does not [Contracting Officer check applicable box] maintain lists of Indian-owned economic enterprises and Indian organizations by specialty (e.g., plumbing, electrical, foundations), which are available to bidders to assist them in meeting their responsibility to provide preference in connection with the administration of contracts and subcontracts.

U.S. Department of Housing and Urban Development –
General Conditions of the Contract for Construction
(Form HUD-5370)

General Conditions for Construction Contracts - Public Housing Programs

U.S. Department of Housing and Urban Development
Office of Public and Indian Housing
OMB Approval No. 2577-0157 (exp. 3/31/2020)

Applicability. This form is applicable to any construction/development contract greater than \$150,000.

This form includes those clauses required by OMB's common rule on grantee procurement, implemented at HUD in 2 CFR 200, and those requirements set forth in Section 3 of the Housing and Urban Development Act of 1968 and its amendment by the Housing and Community Development Act of 1992, implemented by HUD at 24 CFR Part 135. The form is required for construction contracts awarded by Public Housing Agencies (PHAs).

The form is used by Housing Authorities in solicitations to provide necessary contract clauses. If the form were not used, HAs would be unable to enforce their contracts.

Public reporting burden for this collection of information is estimated to average 1.0 hours per response, including the time for reviewing instructions, searching existing data sources, gathering and maintaining the data needed, and completing and reviewing the collection of information. Responses to the collection of information are required to obtain a benefit or to retain a benefit.

The information requested does not lend itself to confidentiality.

HUD may not conduct or sponsor, and a person is not required to respond to a collection of information unless it displays a currently valid OMB number.

Clause		Page	Clause		Page
1.	Definitions	2	Administrative Requirements		
2.	Contractor's Responsibility for Work	2	25.	Contract Period	9
3.	Architect's Duties, Responsibilities and Authority	2	26.	Order of Precedence	9
4.	Other Contracts	3	27.	Payments	9
Construction Requirements			28.	Contract Modifications	10
5.	Preconstruction Conference and Notice to Proceed	3	29.	Changes	10
6.	Construction Progress Schedule	3	30.	Suspension of Work	11
7.	Site Investigation and Conditions Affecting the Work	3	31.	Disputes	11
8.	Differing Site Conditions	4	32.	Default	11
9.	Specifications and Drawings for Construction	4	33.	Liquidated	12
10.	As-Built Drawings	5	34.	Termination of Convenience	12
11.	Material and Workmanship	5	35.	Assignment of Contract	12
12.	Permits and Codes	5	36.	Insurance	12
13.	Health, Safety, and Accident Prevention	6	37.	Subcontracts	13
14.	Temporary Buildings and Transportation Materials	6	38.	Subcontracting with Small and Minority Firms, Women's Business Enterprise, and Labor Surplus Area Firms	13
15.	Availability and Use of Utility Services	6	39.	Equal Employment Opportunity	13
16.	Protection of Existing Vegetation, Structures, Equipment, Utilities, and Improvements	6	40.	Employment, Training, and Contracting Opportunities for Low-Income Persons, Section 3 of the Housing and Urban Development Act of 1968	14
17.	Temporary Buildings and Transportation Materials	7	41.	Interest of Members of Congress	15
18.	Clean Air and Water	7	42.	Interest of Members, Officers, or Employees and Former Members, Officers, or Employees	15
19.	Energy Efficiency	7	43.	Limitations on Payments Made to Influence	15
20.	Inspection and Acceptance of Construction	7	44.	Royalties and Patents	15
21.	Use and Possession Prior to	8	45.	Examination and Retention of Contractor's Records	15
22.	Warranty of Title	8	46.	Labor Standards-Davis-Bacon and Related Acts	15
23.	Warranty of	8	47.	Non-Federal Prevailing Wage Rates	19
24.	Prohibition Against	9	48.	Procurement of Recovered	19

1. Definitions

- (a) "Architect" means the person or other entity engaged by the PHA to perform architectural, engineering, design, and other services related to the work as provided for in the contract. When a PHA uses an engineer to act in this capacity, the terms "architect" and "engineer" shall be synonymous. The Architect shall serve as a technical representative of the Contracting Officer. The Architect's authority is as set forth elsewhere in this contract.
 - (b) "Contract" means the contract entered into between the PHA and the Contractor. It includes the forms of Bid, the Bid Bond, the Performance and Payment Bond or Bonds or other assurance of completion, the Certifications, Representations, and Other Statements of Bidders (form HUD-5370), these General Conditions of the Contract for Construction (form HUD-5370), the applicable wage rate determinations from the U.S. Department of Labor, any special conditions included elsewhere in the contract, the specifications, and drawings. It includes all formal changes to any of those documents by addendum, change order, or other modification.
 - (c) "Contracting Officer" means the person delegated the authority by the PHA to enter into, administer, and/or terminate this contract and designated as such in writing to the Contractor. The term includes any successor Contracting Officer and any duly authorized representative of the Contracting Officer also designated in writing. The Contracting Officer shall be deemed the authorized agent of the PHA in all dealings with the Contractor.
 - (d) "Contractor" means the person or other entity entering into the contract with the PHA to perform all of the work required under the contract.
 - (e) "Drawings" means the drawings enumerated in the schedule of drawings contained in the Specifications and as described in the contract clause entitled Specifications and Drawings for Construction herein.
 - (f) "HUD" means the United States of America acting through the Department of Housing and Urban Development including the Secretary, or any other person designated to act on its behalf. HUD has agreed, subject to the provisions of an Annual Contributions Contract (ACC), to provide financial assistance to the PHA, which includes assistance in financing the work to be performed under this contract. As defined elsewhere in these General Conditions or the contract documents, the determination of HUD may be required to authorize changes in the work or for release of funds to the PHA for payment to the Contractor. Notwithstanding HUD's role, nothing in this contract shall be construed to create any contractual relationship between the Contractor and HUD.
 - (g) "Project" means the entire project, whether construction or rehabilitation, the work for which is provided for in whole or in part under this contract.
 - (h) "PHA" means the Public Housing Agency organized under applicable state laws which is a party to this contract.
 - (j) "Specifications" means the written description of the technical requirements for construction and includes the criteria and tests for determining whether the requirements are met.
 - (l) "Work" means materials, workmanship, and manufacture and fabrication of components.
- (a) The Contractor shall furnish all necessary labor, materials, tools, equipment, and transportation necessary for performance of the work. The Contractor shall also furnish all necessary water, heat, light, and power not made available to the Contractor by the PHA pursuant to the clause entitled Availability and Use of Utility Services herein.
 - (b) The Contractor shall perform on the site, and with its own organization, work equivalent to at least [] (12 percent unless otherwise indicated) of the total amount of work to be performed under the order. This percentage may be reduced by a supplemental agreement to this order if, during performing the work, the Contractor requests a reduction and the Contracting Officer determines that the reduction would be to the advantage of the PHA.
 - (c) At all times during performance of this contract and until the work is completed and accepted, the Contractor shall directly superintend the work or assign and have on the work site a competent superintendent who is satisfactory to the Contracting Officer and has authority to act for the Contractor.
 - (d) The Contractor shall be responsible for all damages to persons or property that occur as a result of the Contractor's fault or negligence, and shall take proper safety and health precautions to protect the work, the workers, the public, and the property of others. The Contractor shall hold and save the PHA, its officers and agents, free and harmless from liability of any nature occasioned by the Contractor's performance. The Contractor shall also be responsible for all materials delivered and work performed until completion and acceptance of the entire work, except for any completed unit of work which may have been accepted under the contract.
 - (e) The Contractor shall lay out the work from base lines and bench marks indicated on the drawings and be responsible for all lines, levels, and measurements of all work executed under the contract. The Contractor shall verify the figures before laying out the work and will be held responsible for any error resulting from its failure to do so.
 - (f) The Contractor shall confine all operations (including storage of materials) on PHA premises to areas authorized or approved by the Contracting Officer.
 - (g) The Contractor shall at all times keep the work area, including storage areas, free from accumulations of waste materials. After completing the work and before final inspection, the Contractor shall (1) remove from the premises all scaffolding, equipment, tools, and materials (including rejected materials) that are not the property of the PHA and all rubbish caused by its work; (2) leave the work area in a clean, neat, and orderly condition satisfactory to the Contracting Officer; (3) perform all specified tests; and, (4) deliver the installation in complete and operating condition.
 - (h) The Contractor's responsibility will terminate when all work has been completed, the final inspection made, and the work accepted by the Contracting Officer. The Contractor will then be released from further obligation except as required by the warranties specified elsewhere in the contract.

3. Architect's Duties, Responsibilities, and Authority

- (a) The Architect for this contract, and any successor, shall be designated in writing by the Contracting Officer.

2. Contractor's Responsibility for Work

-
- (b) The Architect shall serve as the Contracting Officer's technical representative with respect to architectural, engineering, and design matters related to the work performed under the contract. The Architect may provide direction on contract performance. Such direction shall be within the scope of the contract and may not be of a nature which: (1) institutes additional work outside the scope of the contract; (2) constitutes a change as defined in the Changes clause herein; (3) causes an increase or decrease in the cost of the contract; (4) alters the Construction Progress Schedule; or (5) changes any of the other express terms or conditions of the contract.
- (c) The Architect's duties and responsibilities may include but shall not be limited to:
- (1) Making periodic visits to the work site, and on the basis of his/her on-site inspections, issuing written reports to the PHA which shall include all observed deficiencies. The Architect shall file a copy of the report with the Contractor's designated representative at the site;
 - (2) Making modifications in drawings and technical specifications and assisting the Contracting Officer in the preparation of change orders and other contract modifications for issuance by the Contracting Officer;
 - (3) Reviewing and making recommendations with respect to - (i) the Contractor's construction progress schedules; (ii) the Contractor's shop and detailed drawings; (iii) the machinery, mechanical and other equipment and materials or other articles proposed for use by the Contractor; and, (iv) the Contractor's price breakdown and progress payment estimates; and,
 - (4) Assisting in inspections, signing Certificates of Completion, and making recommendations with respect to acceptance of work completed under the contract.

4. Other Contracts

The PHA may undertake or award other contracts for additional work at or near the site of the work under this contract. The Contractor shall fully cooperate with the other contractors and with PHA employees and shall carefully adapt scheduling and performing the work under this contract to accommodate the additional work, heeding any direction that may be provided by the Contracting Officer. The Contractor shall not commit or permit any act that will interfere with the performance of work by any other contractor or by PHA employees

Construction Requirements

5. Pre-construction Conference and Notice to Proceed

- (a) Within ten calendar days of contract execution, and prior to the commencement of work, the Contractor shall attend a preconstruction conference with representatives of the PHA, its Architect, and other interested parties convened by the PHA. The conference will serve to acquaint the participants with the general plan of the construction operation and all other requirements of the contract. The PHA will provide the Contractor with the date, time, and place of the conference.
- (b) The contractor shall begin work upon receipt of a written Notice to Proceed from the Contracting Officer or designee. The Contractor shall not begin work prior to receiving such notice.

6. Construction Progress Schedule

- (a) The Contractor shall, within five days after the work commences on the contract or another period of time determined by the Contracting Officer, prepare and submit to the Contracting Officer for approval three copies of a practicable schedule showing the order in which the Contractor proposes to perform the work, and the dates on which the Contractor contemplates starting and completing the several salient features of the work (including acquiring labor, materials, and equipment). The schedule shall be in the form of a progress chart of suitable scale to indicate appropriately the percentage of work scheduled for completion by any given date during the period. If the Contractor fails to submit a schedule within the time prescribed, the Contracting Officer may withhold approval of progress payments or take other remedies under the contract until the Contractor submits the required schedule.
- (b) The Contractor shall enter the actual progress on the chart as required by the Contracting Officer, and immediately deliver three copies of the annotated schedule to the Contracting Officer. If the Contracting Officer determines, upon the basis of inspection conducted pursuant to the clause entitled Inspection and Acceptance of Construction, herein that the Contractor is not meeting the approved schedule, the Contractor shall take steps necessary to improve its progress, including those that may be required by the Contracting Officer, without additional cost to the PHA. In this circumstance, the Contracting Officer may require the Contractor to increase the number of shifts, overtime operations, days of work, and/or the amount of construction plant, and to submit for approval any supplementary schedule or schedules in chart form as the Contracting Officer deems necessary to demonstrate how the approved rate of progress will be regained.
- (c) Failure of the Contractor to comply with the requirements of the Contracting Officer under this clause shall be grounds for a determination by the Contracting Officer that the Contractor is not prosecuting the work with sufficient diligence to ensure completion within the time specified in the Contract. Upon making this determination, the Contracting Officer may terminate the Contractor's right to proceed with the work, or any separable part of it, in accordance with the Default clause of this contract.

7. Site Investigation and Conditions Affecting the Work

- (a) The Contractor acknowledges that it has taken steps reasonably necessary to ascertain the nature and location of the work, and that it has investigated and satisfied itself as to the general and local conditions which can affect the work or its cost, including but not limited to, (1) conditions bearing upon transportation, disposal, handling, and storage of materials; (2) the availability of labor, water, electric power, and roads; (3) uncertainties of weather, river stages, tides, or similar physical conditions at the site; (4) the conformation and conditions of the ground; and (5) the character of equipment and facilities needed preliminary to and during work performance. The Contractor also acknowledges that it has satisfied itself as to the character, quality, and quantity of surface and subsurface materials or obstacles to be encountered insofar as this information is

reasonably ascertainable from an inspection of the site, including all exploratory work done by the PHA, as well as from the drawings and specifications made a part of this contract. Any failure of the Contractor to take the actions described and acknowledged in this paragraph will not relieve the Contractor from responsibility for estimating properly the difficulty and cost of successfully performing the work, or for proceeding to successfully perform the work without additional expense to the PHA.

- (b) The PHA assumes no responsibility for any conclusions or interpretations made by the Contractor based on the information made available by the PHA. Nor does the PHA assume responsibility for any understanding reached or representation made concerning conditions which can affect the work by any of its officers or agents before the execution of this contract, unless that understanding or representation is expressly stated in this contract.

8. Differing Site Conditions

- (a) The Contractor shall promptly, and before the conditions are disturbed, give a written notice to the Contracting Officer of (1) subsurface or latent physical conditions at the site which differ materially from those indicated in this contract, or (2) unknown physical conditions at the site(s), of an unusual nature, which differ materially from those ordinarily encountered and generally recognized as inhering in work of the character provided for in the contract.
- (b) The Contracting Officer shall investigate the site conditions promptly after receiving the notice. Work shall not proceed at the affected site, except at the Contractor's risk, until the Contracting Officer has provided written instructions to the Contractor. If the conditions do materially so differ and cause an increase or decrease in the Contractor's cost of, or the time required for, performing any part of the work under this contract, whether or not changed as a result of the conditions, the Contractor shall file a claim in writing to the PHA within ten days after receipt of such instructions and, in any event, before proceeding with the work. An equitable adjustment in the contract price, the delivery schedule, or both shall be made under this clause and the contract modified in writing accordingly.
- (c) No request by the Contractor for an equitable adjustment to the contract under this clause shall be allowed, unless the Contractor has given the written notice required; provided, that the time prescribed in (a) above for giving written notice may be extended by the Contracting Officer.
- (d) No request by the Contractor for an equitable adjustment to the contract for differing site conditions shall be allowed if made after final payment under this contract.

9. Specifications and Drawings for Construction

- (a) The Contractor shall keep on the work site a copy of the drawings and specifications and shall at all times give the Contracting Officer access thereto. Anything mentioned in the specifications and not shown on the drawings, or shown on the drawings and not mentioned in the specifications, shall be of like effect as if shown or mentioned in both. In case of difference between drawings and specifications, the specifications shall govern. In case of discrepancy in the figures, in the drawings, or in the specifications, the matter shall be

promptly submitted to the Contracting Officer, who shall promptly make a determination in writing. Any adjustment by the Contractor without such a determination shall be at its own risk and expense. The Contracting Officer shall furnish from time to time such detailed drawings and other information as considered necessary, unless otherwise provided.

- (b) Wherever in the specifications or upon the drawings the words "directed", "required", "ordered", "designated", "prescribed", or words of like import are used, it shall be understood that the "direction", "requirement", "order", "designation", or "prescription", or "the Contracting Officer is intended and similarly the words "approved", "acceptable", "satisfactory", or words of like import shall mean "approved by", or "acceptable to", or "satisfactory to" the Contracting Officer, unless otherwise expressly stated.
- (c) Where "as shown" "as indicated", "as detailed", or of similar import are used, it shall be understood that the reference is made to the drawings accompanying this contract unless stated otherwise. The word "provided" as used herein shall be understood to mean "provide complete in place" that is "furnished and installed".
- (d) "Shop drawings" means drawings, submitted to the PHA by the Contractor, subcontractor, or any lower tier subcontractor, showing in detail (1) the proposed fabrication and assembly of structural elements and (2) the installation (i.e., form, fit, and attachment details) of materials of equipment. It includes drawings, diagrams, layouts, schematics, descriptive literature, illustrations, schedules, performance and test data, and similar materials furnished by the Contractor to explain in detail specific portions of the work required by the contract. The PHA may duplicate, use, and disclose in any manner and for any purpose shop drawings delivered under this contract.
- (e) If this contract requires shop drawings, the Contractor shall coordinate all such drawings, and review them for accuracy, completeness, and compliance with other contract requirements and shall indicate its approval thereon as evidence of such coordination and review. Shop drawings submitted to the Contracting Officer without evidence of the Contractor's approval may be returned for resubmission. The Contracting Officer will indicate an approval or disapproval of the shop drawings and if not approved as submitted shall indicate the PHA's reasons therefore. Any work done before such approval shall be at the Contractor's risk. Approval by the Contracting Officer shall not relieve the Contractor from responsibility for any errors or omissions in such drawings, nor from responsibility for complying with the requirements of this contract, except with respect to variations described and approved in accordance with (f) below.
- (f) If shop drawings show variations from the contract requirements, the Contractor shall describe such variations in writing, separate from the drawings, at the time of submission. If the Architect approves any such variation and the Contracting Officer concurs, the Contracting Officer shall issue an appropriate modification to the contract, except that, if the variation is minor or does not involve a change in price or in time of performance, a modification need not be issued.
- (g) It shall be the responsibility of the Contractor to make timely requests of the PHA for such large scale and full size drawings, color schemes, and other additional information, not already in his possession, which shall be

required in the planning and production of the work. Such requests may be submitted as the need arises, but each such request shall be filed in ample time to permit appropriate action to be taken by all parties involved so as to avoid delay.

- (h) The Contractor shall submit to the Contracting Officer for approval four copies (unless otherwise indicated) of all shop drawings as called for under the various headings of these specifications. Three sets (unless otherwise indicated) of all shop drawings, will be retained by the PHA and one set will be returned to the Contractor. As required by the Contracting Officer, the Contractor, upon completing the work under this contract, shall furnish a complete set of all shop drawings as finally approved. These drawings shall show all changes and revisions made up to the time the work is completed and accepted.
- (i) This clause shall be included in all subcontracts at any tier. It shall be the responsibility of the Contractor to ensure that all shop drawings prepared by subcontractors are submitted to the Contracting Officer.

10. As-Built Drawings

- (a) "As-built drawings," as used in this clause, means drawings submitted by the Contractor or subcontractor at any tier to show the construction of a particular structure or work as actually completed under the contract. "As-built drawings" shall be synonymous with "Record drawings."
- (b) As required by the Contracting Officer, the Contractor shall provide the Contracting Officer accurate information to be used in the preparation of permanent as-built drawings. For this purpose, the Contractor shall record on one set of contract drawings all changes from the installations originally indicated, and record final locations of underground lines by depth from finish grade and by accurate horizontal offset distances to permanent surface improvements such as buildings, curbs, or edges of walks.
- (c) This clause shall be included in all subcontracts at any tier. It shall be the responsibility of the Contractor to ensure that all as-built drawings prepared by subcontractors are submitted to the Contracting Officer.

11. Material and Workmanship

- (a) All equipment, material, and articles furnished under this contract shall be new and of the most suitable grade for the purpose intended, unless otherwise specifically provided in this contract. References in the contract to equipment, material, articles, or patented processes by trade name, make, or catalog number, shall be regarded as establishing a standard of quality and shall not be construed as limiting competition. The Contractor may, at its option, use any equipment, material, article, or process that, in the judgment of, and as approved by the Contracting Officer, is equal to that named in the specifications, unless otherwise specifically provided in this contract.
- (b) Approval of equipment and materials.
 - (1) The Contractor shall obtain the Contracting Officer's approval of the machinery and mechanical and other equipment to be incorporated into the work. When requesting approval, the Contractor shall furnish to the Contracting Officer the name of the manufacturer, the model number, and other information concerning the performance, capacity, nature, and rating of the

machinery and mechanical and other equipment. When required by this contract or by the Contracting Officer, the Contractor shall also obtain the Contracting Officer's approval of the material or articles which the Contractor contemplates incorporating into the work. When requesting approval, the Contractor shall provide full information concerning the material or articles. Machinery, equipment, material, and articles that do not have the required approval shall be installed or used at the risk of subsequent rejection.

- (2) When required by the specifications or the Contracting Officer, the Contractor shall submit appropriately marked samples (and certificates related to them) for approval at the Contractor's expense, with all shipping charges prepaid. The Contractor shall label, or otherwise properly mark on the container, the material or product represented, its place of origin, the name of the producer, the Contractor's name, and the identification of the construction project for which the material or product is intended to be used.
- (3) Certificates shall be submitted in triplicate, describing each sample submitted for approval and certifying that the material, equipment or accessory complies with contract requirements. The certificates shall include the name and brand of the product, name of manufacturer, and the location where produced.
- (4) Approval of a sample shall not constitute a waiver of the PHA right to demand full compliance with contract requirements. Materials, equipment and accessories may be rejected for cause even though samples have been approved.
- (5) Wherever materials are required to comply with recognized standards or specifications, such specifications shall be accepted as establishing the technical qualities and testing methods, but shall not govern the number of tests required to be made nor modify other contract requirements. The Contracting Officer may require laboratory test reports on items submitted for approval or may approve materials on the basis of data submitted in certificates with samples. Check tests will be made on materials delivered for use only as frequently as the Contracting Officer determines necessary to insure compliance of materials with the specifications. The Contractor will assume all costs of retesting materials which fail to meet contract requirements and/or testing materials offered in substitution for those found deficient.
- (6) After approval, samples will be kept in the Project office until completion of work. They may be built into the work after a substantial quantity of the materials they represent has been built in and accepted.
- (c) Requirements concerning lead-based paint. The Contractor shall comply with the requirements concerning lead-based paint contained in the Lead-Based Paint Poisoning Prevention Act (42 U.S.C. 4821-4846) as implemented by 24 CFR Part 35.

12. Permits and Codes

- (a) The Contractor shall give all notices and comply with all applicable laws, ordinances, codes, rules and regulations. Notwithstanding the requirement of the Contractor to comply with the drawings and specifications in the contract, all work installed shall comply with all applicable codes and regulations as amended by any

waivers. Before installing the work, the Contractor shall examine the drawings and the specifications for compliance with applicable codes and regulations bearing on the work and shall immediately report any discrepancy it may discover to the Contracting Officer. Where the requirements of the drawings and specifications fail to comply with the applicable code or regulation, the Contracting Officer shall modify the contract by change order pursuant to the clause entitled Changes herein to conform to the code or regulation.

- (b) The Contractor shall secure and pay for all permits, fees, and licenses necessary for the proper execution and completion of the work. Where the PHA can arrange for the issuance of all or part of these permits, fees and licenses, without cost to the Contractor, the contract amount shall be reduced accordingly.

13. Health, Safety, and Accident Prevention

- (a) In performing this contract, the Contractor shall:
 - (1) Ensure that no laborer or mechanic shall be required to work in surroundings or under working conditions which are unsanitary, hazardous, or dangerous to his/her health and/or safety as determined under construction safety and health standards promulgated by the Secretary of Labor by regulation;
 - (2) Protect the lives, health, and safety of other persons;
 - (3) Prevent damage to property, materials, supplies, and equipment; and,
 - (4) Avoid work interruptions.
- (b) For these purposes, the Contractor shall:
 - (1) Comply with regulations and standards issued by the Secretary of Labor at 29 CFR Part 1926. Failure to comply may result in imposition of sanctions pursuant to the Contract Work Hours and Safety Standards Act (Public Law 91-54, 83 Stat. 96), 40 U.S.C. 3701 et seq.; and
 - (2) Include the terms of this clause in every subcontract so that such terms will be binding on each subcontractor.
- (c) The Contractor shall maintain an accurate record of exposure data on all accidents incident to work performed under this contract resulting in death, traumatic injury, occupational disease, or damage to property, materials, supplies, or equipment, and shall report this data in the manner prescribed by 29 CFR Part 1904.
- (d) The Contracting Officer shall notify the Contractor of any noncompliance with these requirements and of the corrective action required. This notice, when delivered to the Contractor or the Contractor's representative at the site of the work, shall be deemed sufficient notice of the noncompliance and corrective action required. After receiving the notice, the Contractor shall immediately take corrective action. If the Contractor fails or refuses to take corrective action promptly, the Contracting Officer may issue an order stopping all or part of the work until satisfactory corrective action has been taken. The Contractor shall not base any claim or request for equitable adjustment for additional time or money on any stop order issued under these circumstances.
- (e) The Contractor shall be responsible for its subcontractors' compliance with the provisions of this clause. The Contractor shall take such action with respect to any subcontract as the PHA, the Secretary of Housing and Urban Development, or the Secretary of Labor shall direct as a means of enforcing such provisions.

14. Temporary Heating

The Contractor shall provide and pay for temporary heating, covering, and enclosures necessary to properly protect all work and materials against damage by dampness and cold, to dry out the work, and to facilitate the completion of the work. Any permanent heating equipment used shall be turned over to the PHA in the condition and at the time required by the specifications.

15. Availability and Use of Utility Services

- (a) The PHA shall make all reasonably required amounts of utilities available to the Contractor from existing outlets and supplies, as specified in the contract. Unless otherwise provided in the contract, the amount of each utility service consumed shall be charged to or paid for by the Contractor at prevailing rates charged to the PHA or, where the utility is produced by the PHA, at reasonable rates determined by the Contracting Officer. The Contractor shall carefully conserve any utilities furnished without charge.
- (b) The Contractor, at its expense and in a manner satisfactory to the Contracting Officer, shall install and maintain all necessary temporary connections and distribution lines, and all meters required to measure the amount of each utility used for the purpose of determining charges. Before final acceptance of the work by the PHA, the Contractor shall remove all the temporary connections, distribution lines, meters, and associated paraphernalia.

16. Protection of Existing Vegetation, Structures, Equipment, Utilities, and Improvements

- (a) The Contractor shall preserve and protect all structures, equipment, and vegetation (such as trees, shrubs, and grass) on or adjacent to the work site, which are not to be removed under this contract, and which do not unreasonably interfere with the work required under this contract.
- (b) The Contractor shall only remove trees when specifically authorized to do so, and shall avoid damaging vegetation that will remain in place. If any limbs or branches of trees are broken during performance of this contract, or by the careless operation of equipment, or by workmen, the Contractor shall trim those limbs or branches with a clean cut and paint the cut with a tree-pruning compound as directed by the Contracting Officer.
- (c) The Contractor shall protect from damage all existing improvements and utilities (1) at or near the work site and (2) on adjacent property of a third party, the locations of which are made known to or should be known by the Contractor. Prior to disturbing the ground at the construction site, the Contractor shall ensure that all underground utility lines are clearly marked.
- (d) The Contractor shall shore up, brace, underpin, secure, and protect as necessary all foundations and other parts of existing structures adjacent to, adjoining, and in the vicinity of the site, which may be affected by the excavations or other operations connected with the construction of the project.
- (e) Any equipment temporarily removed as a result of work under this contract shall be protected, cleaned, and replaced in the same condition as at the time of award of this contract.

- (f) New work which connects to existing work shall correspond in all respects with that to which it connects and/or be similar to existing work unless otherwise required by the specifications.
- (g) No structural members shall be altered or in any way weakened without the written authorization of the Contracting Officer, unless such work is clearly specified in the plans or specifications.
- (h) If the removal of the existing work exposes discolored or unfinished surfaces, or work out of alignment, such surfaces shall be refinished, or the material replaced as necessary to make the continuous work uniform and harmonious. This, however, shall not be construed to require the refinishing or reconstruction of dissimilar finishes previously exposed, or finished surfaces in good condition, but in different planes or on different levels when brought together by the removal of intervening work, unless such refinishing or reconstruction is specified in the plans or specifications.
- (i) The Contractor shall give all required notices to any adjoining or adjacent property owner or other party before the commencement of any work.
- (j) The Contractor shall indemnify and save harmless the PHA from any damages on account of settlement or the loss of lateral support of adjoining property, any damages from changes in topography affecting drainage, and from all loss or expense and all damages for which the PHA may become liable in consequence of such injury or damage to adjoining and adjacent structures and their premises.
- (k) The Contractor shall repair any damage to vegetation, structures, equipment, utilities, or improvements, including those that are the property of a third party, resulting from failure to comply with the requirements of this contract or failure to exercise reasonable care in performing the work. If the Contractor fails or refuses to repair the damage promptly, the Contracting Officer may have the necessary work performed and charge the cost to the Contractor.

17. Temporary Buildings and Transportation of Materials

- (a) Temporary buildings (e.g., storage sheds, shops, offices, sanitary facilities) and utilities may be erected by the Contractor only with the approval of the Contracting Officer and shall be built with labor and materials furnished by the Contractor without expense to the PHA. The temporary buildings and utilities shall remain the property of the Contractor and shall be removed by the Contractor at its expense upon completion of the work. With the written consent of the Contracting Officer, the buildings and utilities may be abandoned and need not be removed.
- (b) The Contractor shall, as directed by the Contracting Officer, use only established roadways, or use temporary roadways constructed by the Contractor when and as authorized by the Contracting Officer. When materials are transported in prosecuting the work, vehicles shall not be loaded beyond the loading capacity recommended by the manufacturer of the vehicle or prescribed by any federal, state, or local law or regulation. When it is necessary to cross curbs or sidewalks, the Contractor shall protect them from damage. The Contractor shall repair or pay for the repair of any damaged curbs, sidewalks, or roads.

18. Clean Air and Water

The contractor shall comply with the Clean Air Act, as amended, 42 USC 7401 et seq., the Federal Water Pollution Control Water Act, as amended, 33 U.S.C. 1251 et seq., and standards issued pursuant thereto in the facilities in which this contract is to be performed.

19. Energy Efficiency

The Contractor shall comply with mandatory standards and policies relating to energy efficiency which are contained in the energy conservation plan issued in compliance with the Energy Policy and Conservation Act (Pub.L. 94-163) for the State in which the work under the contract is performed.

20. Inspection and Acceptance of Construction

- (a) Definitions. As used in this clause -
 - (1) "Acceptance" means the act of an authorized representative of the PHA by which the PHA approves and assumes ownership of the work performed under this contract. Acceptance may be partial or complete.
 - (2) "Inspection" means examining and testing the work performed under the contract (including, when appropriate, raw materials, equipment, components, and intermediate assemblies) to determine whether it conforms to contract requirements.
 - (3) "Testing" means that element of inspection that determines the properties or elements, including functional operation of materials, equipment, or their components, by the application of established scientific principles and procedures.
- (b) The Contractor shall maintain an adequate inspection system and perform such inspections as will ensure that the work performed under the contract conforms to contract requirements. All work is subject to PHA inspection and test at all places and at all reasonable times before acceptance to ensure strict compliance with the terms of the contract.
- (c) PHA inspections and tests are for the sole benefit of the PHA and do not: (1) relieve the Contractor of responsibility for providing adequate quality control measures; (2) relieve the Contractor of responsibility for loss or damage of the material before acceptance; (3) constitute or imply acceptance; or, (4) affect the continuing rights of the PHA after acceptance of the completed work under paragraph (j) below.
- (d) The presence or absence of the PHA inspector does not relieve the Contractor from any contract requirement, nor is the inspector authorized to change any term or condition of the specifications without the Contracting Officer's written authorization. All instructions and approvals with respect to the work shall be given to the Contractor by the Contracting Officer.
- (e) The Contractor shall promptly furnish, without additional charge, all facilities, labor, and material reasonably needed for performing such safe and convenient inspections and tests as may be required by the Contracting Officer. The PHA may charge to the Contractor any additional cost of inspection or test when work is not ready at the time specified by the Contractor for inspection or test, or when prior rejection makes reinspection or retest necessary. The PHA shall perform all inspections and tests in a manner that will not unnecessarily delay the work. Special, full size, and performance tests shall be performed as described in the contract.

- (f) The PHA may conduct routine inspections of the construction site on a daily basis.
- (g) The Contractor shall, without charge, replace or correct work found by the PHA not to conform to contract requirements, unless the PHA decides that it is in its interest to accept the work with an appropriate adjustment in contract price. The Contractor shall promptly segregate and remove rejected material from the premises.
- (h) If the Contractor does not promptly replace or correct rejected work, the PHA may (1) by contract or otherwise, replace or correct the work and charge the cost to the Contractor, or (2) terminate for default the Contractor's right to proceed.
- (i) If any work requiring inspection is covered up without approval of the PHA, it must, if requested by the Contracting Officer, be uncovered at the expense of the Contractor. If at any time before final acceptance of the entire work, the PHA considers it necessary or advisable, to examine work already completed by removing or tearing it out, the Contractor, shall on request, promptly furnish all necessary facilities, labor, and material. If such work is found to be defective or nonconforming in any material respect due to the fault of the Contractor or its subcontractors, the Contractor shall defray all the expenses of the examination and of satisfactory reconstruction. If, however, such work is found to meet the requirements of the contract, the Contracting Officer shall make an equitable adjustment to cover the cost of the examination and reconstruction, including, if completion of the work was thereby delayed, an extension of time.
- (j) The Contractor shall notify the Contracting Officer, in writing, as to the date when in its opinion all or a designated portion of the work will be substantially completed and ready for inspection. If the Architect determines that the state of preparedness is as represented, the PHA will promptly arrange for the inspection. Unless otherwise specified in the contract, the PHA shall accept, as soon as practicable after completion and inspection, all work required by the contract or that portion of the work the Contracting Officer determines and designates can be accepted separately. Acceptance shall be final and conclusive except for latent defects, fraud, gross mistakes amounting to fraud, or the PHA's right under any warranty or guarantee.

21. Use and Possession Prior to Completion

- (a) The PHA shall have the right to take possession of or use any completed or partially completed part of the work. Before taking possession of or using any work, the Contracting Officer shall furnish the Contractor a list of items of work remaining to be performed or corrected on those portions of the work that the PHA intends to take possession of or use. However, failure of the Contracting Officer to list any item of work shall not relieve the Contractor of responsibility for complying with the terms of the contract. The PHA's possession or use shall not be deemed an acceptance of any work under the contract.
- (b) While the PHA has such possession or use, the Contractor shall be relieved of the responsibility for (1) the loss of or damage to the work resulting from the PHA's possession or use, notwithstanding the terms of the clause entitled Permits and Codes herein; (2) all maintenance costs on the areas occupied; and, (3) furnishing heat, light, power, and water used in the areas

occupied without proper remuneration therefore. If prior possession or use by the PHA delays the progress of the work or causes additional expense to the Contractor, an equitable adjustment shall be made in the contract price or the time of completion, and the contract shall be modified in writing accordingly.

22. Warranty of Title

The Contractor warrants good title to all materials, supplies, and equipment incorporated in the work and agrees to deliver the premises together with all improvements thereon free from any claims, liens or charges, and agrees further that neither it nor any other person, firm or corporation shall have any right to a lien upon the premises or anything appurtenant thereto.

23. Warranty of Construction

- (a) In addition to any other warranties in this contract, the Contractor warrants, except as provided in paragraph (j) of this clause, that work performed under this contract conforms to the contract requirements and is free of any defect in equipment, material, or workmanship performed by the Contractor or any subcontractor or supplier at any tier. This warranty shall continue for a period of _____ (one year unless otherwise indicated) from the date of final acceptance of the work. If the PHA takes possession of any part of the work before final acceptance, this warranty shall continue for a period of (one year unless otherwise indicated) from the date that the PHA takes possession.
- (b) The Contractor shall remedy, at the Contractor's expense, any failure to conform, or any defect. In addition, the Contractor shall remedy, at the Contractor's expense, any damage to PHA-owned or controlled real or personal property when the damage is the result of—
 - (1) The Contractor's failure to conform to contract requirements; or
 - (2) Any defects of equipment, material, workmanship or design furnished by the Contractor.
- (c) The Contractor shall restore any work damaged in fulfilling the terms and conditions of this clause. The Contractor's warranty with respect to work repaired or replaced will run for (one year unless otherwise indicated) from the date of repair or replacement.
- (d) The Contracting Officer shall notify the Contractor, in writing, within a reasonable time after the discovery of any failure, defect or damage.
- (e) If the Contractor fails to remedy any failure, defect, or damage within a reasonable time after receipt of notice, the PHA shall have the right to replace, repair or otherwise remedy the failure, defect, or damage at the Contractor's expense.
- (f) With respect to all warranties, express or implied, from subcontractors, manufacturers, or suppliers for work performed and materials furnished under this contract, the Contractor shall:
 - (1) Obtain all warranties that would be given in normal commercial practice;
 - (2) Require all warranties to be executed in writing, for the benefit of the PHA; and,
 - (3) Enforce all warranties for the benefit of the PHA.
- (g) In the event the Contractor's warranty under paragraph (a) of this clause has expired, the PHA may bring suit at its own expense to enforce a subcontractor's, manufacturer's or supplier's warranty.

- (h) Unless a defect is caused by the negligence of the Contractor or subcontractor or supplier at any tier, the Contractor shall not be liable for the repair of any defect of material or design furnished by the PHA nor for the repair of any damage that results from any defect in PHA furnished material or design.
- (i) Notwithstanding any provisions herein to the contrary, the establishment of the time periods in paragraphs (a) and (c) above relate only to the specific obligation of the Contractor to correct the work, and have no relationship to the time within which its obligation to comply with the contract may be sought to be enforced, nor to the time within which proceedings may be commenced to establish the Contractor's liability with respect to its obligation other than specifically to correct the work.
- (j) This warranty shall not limit the PHA's rights under the Inspection and Acceptance of Construction clause of this contract with respect to latent defects, gross mistakes or fraud.

24. Prohibition Against Liens

The Contractor is prohibited from placing a lien on the PHA's property. This prohibition shall apply to all subcontractors at any tier and all materials suppliers.

Administrative Requirements

25. Contract Period

this contract within _____ calendar days of the effective date of the contract, or within the time schedule established in the notice to proceed issued by the Contracting Officer.

26. Order of Provisions

In the event of a conflict between these General Conditions and the Specifications, the General Conditions shall prevail. In the event of a conflict between the contract and any applicable state or local law or regulation, the state or local law or regulation shall prevail; provided that such state or local law or regulation does not conflict with, or is less restrictive than applicable federal law, regulation, or Executive Order. In the event of such a conflict, applicable federal law, regulation, and Executive Order shall prevail.

27. Payments

- (a) The PHA shall pay the Contractor the price as provided in this contract.
- (b) The PHA shall make progress payments approximately every 30 days as the work proceeds, on estimates of work accomplished which meets the standards of quality established under the contract, as approved by the Contracting Officer. The PHA may, subject to written determination and approval of the Contracting Officer, make more frequent payments to contractors which are qualified small businesses.
- (c) Before the first progress payment under this contract, the Contractor shall furnish, in such detail as requested by the Contracting Officer, a breakdown of the total contract price showing the amount included therein for each principal category of the work, which shall substantiate the payment amount requested in order to provide a

basis for determining progress payments. The breakdown shall be approved by the Contracting Officer and must be acceptable to HUD. If the contract covers more than one project, the Contractor shall furnish a separate breakdown for each. The values and quantities employed in making up this breakdown are for determining the amount of progress payments and shall not be construed as a basis for additions to or deductions from the contract price. The Contractor shall prorate its overhead and profit over the construction period of the contract.

- (d) The Contractor shall submit, on forms provided by the PHA, periodic estimates showing the value of the work performed during each period based upon the approved submitted not later than _____ days in advance of the date set for payment and are subject to correction and revision as required. The estimates must be approved by the Contracting Officer with the concurrence of the Architect prior to payment. If the contract covers more than one project, the Contractor shall furnish a separate progress payment estimate for each.
- (e) Along with each request for progress payments and the required estimates, the Contractor shall furnish the following certification, or payment shall not be made: I hereby certify, to the best of my knowledge and belief, that:
 - (1) The amounts requested are only for performance in accordance with the specifications, terms, and conditions of the contract;
 - (2) Payments to subcontractors and suppliers have been made from previous payments received under the contract, and timely payments will be made from the proceeds of the payment covered by this certification, in accordance with subcontract agreements; and,
 - (3) This request for progress payments does not include any amounts which the prime contractor intends to withhold or retain from a subcontractor or supplier in accordance with the terms and conditions of the subcontract.

Name:

Title:

Date:

- (f) Except as otherwise provided in State law, the PHA shall retain ten (10) percent of the amount of progress payments until completion and acceptance of all work under the contract; except, that if upon completion of 50 percent of the work, the Contracting Officer, after consulting with the Architect, determines that the Contractor's performance and progress are satisfactory, the PHA may make the remaining payments in full for the work subsequently completed. If the Contracting Officer subsequently determines that the Contractor's performance and progress are unsatisfactory, the PHA shall reinstate the ten (10) percent (or other percentage as provided in State law) retainage until such time as the Contracting Officer determines that performance and progress are satisfactory.
- (g) The Contracting Officer may authorize material delivered on the site and preparatory work done to be taken into consideration when computing progress payments.

Material delivered to the Contractor at locations other than the site may also be taken into consideration if the Contractor furnishes satisfactory evidence that (1) it has acquired title to such material; (2) the material is properly stored in a bonded warehouse, storage yard, or similar suitable place as may be approved by the Contracting Officer; (3) the material is insured to cover its full value; and (4) the material will be used to perform this contract. Before any progress payment which includes delivered material is made, the Contractor shall furnish such documentation as the Contracting Officer may require to assure the protection of the PHA's interest in such materials. The Contractor shall remain responsible for such stored material notwithstanding the transfer of title to the PHA.

- (h) All material and work covered by progress payments made shall, at the time of payment become the sole property of the PHA, but this shall not be construed as (1) relieving the Contractor from the sole responsibility for all material and work upon which payments have been made or the restoration of any damaged work; or, (2) waiving the right of the PHA to require the fulfillment of all of the terms of the contract. In the event the work of the Contractor has been damaged by other contractors or persons other than employees of the PHA in the course of their employment, the Contractor shall restore such damaged work without cost to the PHA and to seek redress for its damage only from those who directly caused it.
- (i) The PHA shall make the final payment due the Contractor under this contract after (1) completion and final acceptance of all work; and (2) presentation of release of all claims against the PHA arising by virtue of this contract, other than claims, in stated amounts, that the Contractor has specifically excepted from the operation of the release. Each such exception shall embrace no more than one claim, the basis and scope of which shall be clearly defined. The amounts for such excepted claims shall not be included in the request for final payment. A release may also be required of the assignee if the Contractor's claim to amounts payable under this contract has been assigned.
- (j) Prior to making any payment, the Contracting Officer may require the Contractor to furnish receipts or other evidence of payment from all persons performing work and supplying material to the Contractor, if the Contracting Officer determines such evidence is necessary to substantiate claimed costs.
- (k) The PHA shall not; (1) determine or adjust any claims for payment or disputes arising there under between the Contractor and its subcontractors or material suppliers; or, (2) withhold any moneys for the protection of the subcontractors or material suppliers. The failure or refusal of the PHA to withhold moneys from the Contractor shall in no wise impair the obligations of any surety or sureties under any bonds furnished under this contract.

28. Contract Modifications

- (a) Only the Contracting Officer has authority to modify any term or condition of this contract. Any contract modification shall be authorized in writing.
- (b) The Contracting Officer may modify the contract unilaterally (1) pursuant to a specific authorization stated in a contract clause (e.g., Changes); or (2) for administrative matters which do not change the rights or

responsibilities of the parties (e.g., change in the PHA address). All other contract modifications shall be in the form of supplemental agreements signed by the Contractor and the Contracting Officer.

- (c) When a proposed modification requires the approval of HUD prior to its issuance (e.g., a change order that exceeds the PHA's approved threshold), such modification shall not be effective until the required approval is received by the PHA.

29. Changes

- (a) The Contracting Officer may, at any time, without notice to the sureties, by written order designated or indicated to be a change order, make changes in the work within the general scope of the contract including changes:
 - (1) In the specifications (including drawings and designs);
 - (2) In the method or manner of performance of the work;
 - (3) PHA-furnished facilities, equipment, materials, services, or site; or,
 - (4) Directing the acceleration in the performance of the work.
- (b) Any other written order or oral order (which, as used in this paragraph (b), includes direction, instruction, interpretation, or determination) from the Contracting Officer that causes a change shall be treated as a change order under this clause; provided, that the Contractor gives the Contracting Officer written notice stating (1) the date, circumstances and source of the order and (2) that the Contractor regards the order as a change order.
- (c) Except as provided in this clause, no order, statement or conduct of the Contracting Officer shall be treated as a change under this clause or entitle the Contractor to an equitable adjustment.
- (d) If any change under this clause causes an increase or decrease in the Contractor's cost of, or the time required for the performance of any part of the work under this contract, whether or not changed by any such order, the Contracting Officer shall make an equitable adjustment and modify the contract in writing. However, except for a adjustment based on defective specifications, no proposal for any change under paragraph (b) above shall be allowed for any costs incurred more than 20 days (5 days for oral orders) before the Contractor gives written notice as required. In the case of defective specifications for which the PHA is responsible, the equitable adjustment shall include any increased cost reasonably incurred by the Contractor in attempting to comply with the defective specifications.
- (e) The Contractor must assert its right to an adjustment under this clause within 30 days after (1) receipt of a written change order under paragraph (a) of this clause, or (2) the furnishing of a written notice under paragraph (b) of this clause, by submitting a written statement describing the general nature and the amount of the proposal. If the facts justify it, the Contracting Officer may extend the period for submission. The proposal may be included in the notice required under paragraph (b) above. No proposal by the Contractor for an equitable adjustment shall be allowed if asserted after final payment under this contract.
- (f) The Contractor's written proposal for equitable adjustment shall be submitted in the form of a lump sum proposal supported with an itemized breakdown of all increases and decreases in the contract in at least the following details:

- (1) Direct Costs. Materials (list individual items, the quantity and unit cost of each, and the aggregate cost); Transportation and delivery costs associated with materials; Labor breakdowns by hours or unit costs (identified with specific work to be performed); Construction equipment exclusively necessary for the change; Costs of preparation and/ or revision to shop drawings resulting from the change; Worker's Compensation and Public Liability Insurance; Employment taxes under FICA and FUTA; and, Bond Costs when size of change warrants revision.
- (2) Indirect Costs. Indirect costs may include overhead, general and administrative expenses, and fringe benefits not normally treated as direct costs.
- (3) Profit. The amount of profit shall be negotiated and may vary according to the nature, extent, and complexity of the work required by the change. The allowability of the direct and indirect costs shall be determined in accordance with the Contract Cost Principles and Procedures for Commercial Firms in Part 31 of the Federal Acquisition Regulation (48 CFR 1-31), as implemented by HUD Handbook 2210.18, in effect on the date of this contract. The Contractor shall not be allowed a profit on the profit received by any subcontractor. Equitable adjustments for deleted work shall include a credit for profit and may include a credit for indirect costs. On proposals covering both increases and decreases in the amount of the contract, the application of indirect costs and profit shall be on the net-change in direct costs for the Contractor or subcontractor performing the work.
- (g) The Contractor shall include in the proposal its request for time extension (if any), and shall include sufficient information and dates to demonstrate whether and to what extent the change will delay the completion of the contract in its entirety.
- (h) The Contracting Officer shall act on proposals within 30 days after their receipt, or notify the Contractor of the date when such action will be taken.
- (i) Failure to reach an agreement on any proposal shall be a dispute under the clause entitled Disputes herein. Nothing in this clause, however, shall excuse the Contractor from proceeding with the contract as changed.
- (j) Except in an emergency endangering life or property, no change shall be made by the Contractor without a prior order from the Contracting Officer.

30. Suspension of Work

- (a) The Contracting Officer may order the Contractor in writing to suspend, delay, or interrupt all or any part of the work of this contract for the period of time that the Contracting Officer determines appropriate for the convenience of the PHA.
- (b) If the performance of all or any part of the work is, for an unreasonable period of time, suspended, delayed, or interrupted (1) by an act of the Contracting Officer in the administration of this contract, or (2) by the Contracting Officer's failure to act within the time specified (or within a reasonable time if not specified) in this contract an adjustment shall be made for any increase in the cost of performance of the contract (excluding profit) necessarily caused by such unreasonable suspension, delay, or interruption and the contract modified in writing accordingly. However, no adjustment shall be made under this clause for any suspension, delay, or interruption to the extent that performance would have

been so suspended, delayed, or interrupted by any other cause, including the fault or negligence of the Contractor or for which any equitable adjustment is provided for or excluded under any other provision of this contract.

- (c) A claim under this clause shall not be allowed (1) for any costs incurred more than 20 days before the Contractor shall have notified the Contracting Officer in writing of the act or failure to act involved (but this requirement shall not apply as to a claim resulting from a suspension order); and, (2) unless the claim, in an amount stated, is asserted in writing as soon as practicable after the termination of the suspension, delay, or interruption, but not later than the date of final payment under the contract.

31. Disputes

- (a) "Claim," as used in this clause, means a written demand or written assertion by one of the contracting parties seeking, as a matter of right, the payment of money in a sum certain, the adjustment or interpretation of contract terms, or other relief arising under or relating to the contract. A claim arising under the contract, unlike a claim relating to the contract, is a claim that can be resolved under a contract clause that provides for the relief sought by the claimant. A voucher, invoice, or other routine request for payment that is not in dispute when submitted is not a claim. The submission may be converted to a claim by complying with the requirements of this clause, if it is disputed either as to liability or amount or is not acted upon in a reasonable time.
- (b) Except for disputes arising under the clauses entitled Labor Standards - Davis Bacon and Related Acts, herein, all disputes arising under or relating to this contract, including any claims for damages for the alleged breach thereof which are not disposed of by agreement, shall be resolved under this clause.
- (c) All claims by the Contractor shall be made in writing and submitted to the Contracting Officer for a written decision. A claim by the PHA against the Contractor shall be subject to a written decision by the Contracting Officer.
- (d) The Contracting Officer shall, within 60 (unless otherwise indicated) days after receipt of the request, decide the claim or notify the Contractor of the date by which the decision will be made.
- (e) The Contracting Officer's decision shall be final unless the Contractor (1) appeals in writing to a higher level in the PHA in accordance with the PHA's policy and procedures, (2) refers the appeal to an independent mediator or arbitrator, or (3) files suit in a court of competent jurisdiction. Such appeal must be made within (30 unless otherwise indicated) days after receipt of the Contracting Officer's decision.
- (f) The Contractor shall proceed diligently with performance of this contract, pending final resolution of any request for relief, claim, appeal, or action arising under or relating to the contract, and comply with any decision of the Contracting Officer.

32. Default

- (a) If the Contractor refuses or fails to prosecute the work, or any separable part thereof, with the diligence that will insure its completion within the time specified in this contract, or any extension thereof, or fails to complete said work within this time, the Contracting Officer may, by written notice to the Contractor, terminate the right to

proceed with the work (or separable part of the work) that has been delayed. In this event, the PHA may take over the work and complete it, by contract or otherwise, and may take possession of and use any materials, equipment, and plant on the work site necessary for completing the work. The Contractor and its sureties shall be liable for any damage to the PHA resulting from the Contractor's refusal or failure to complete the work within the specified time, whether or not the Contractor's right to proceed with the work is terminated. This liability includes any increased costs incurred by the PHA in completing the work.

- (b) The Contractor's right to proceed shall not be terminated or the Contractor charged with damages under this clause if—
- (1) The delay in completing the work arises from unforeseeable causes beyond the control and without the fault or negligence of the Contractor. Examples of such causes include (i) acts of God, or of the public enemy, (ii) acts of the PHA or other governmental entity in either its sovereign or contractual capacity, (iii) acts of another contractor in the performance of a contract with the PHA, (iv) fires, (v) floods, (vi) epidemics, (vii) quarantine restrictions, (viii) strikes, (ix) freight embargoes, (x) unusually severe weather, or (xi) delays of subcontractors or suppliers at any tier arising from unforeseeable causes beyond the control and without the fault or negligence of both the Contractor and the subcontractors or suppliers; and
 - (2) The Contractor, within days (10 days unless otherwise indicated) from the beginning of such delay (unless extended by the Contracting Officer) notifies the Contracting Officer in writing of the causes of delay. The Contracting Officer shall ascertain the facts and the extent of the delay. If, in the judgment of the Contracting Officer, the findings of fact warrant such action, time for completing the work shall be extended by written modification to the contract. The findings of the Contracting Officer shall be reduced to a written decision which shall be subject to the provisions of the Disputes clause of this contract.
- (c) If, after termination of the Contractor's right to proceed, it is determined that the Contractor was not in default, or that the delay was excusable, the rights and obligations of the parties will be the same as if the termination had been for convenience of the PHA.

33. Liquidated Damages

- (a) If the Contractor fails to complete the work within the time specified in the contract, or any extension, as specified in the clause entitled Default of this contract, the Contractor shall pay to the PHA as liquidated damages, the sum of \$ _____ [Contracting Officer insert amount] for each day of delay. If different completion dates are specified in the contract for separate parts or stages of the work, the amount of liquidated damages shall be assessed on those parts or stages which are delayed. To the extent that the Contractor's delay or nonperformance is excused under another clause in this contract, liquidated damages shall not be due the PHA. The Contractor remains liable for damages caused other than by delay.
- (b) If the PHA terminates the Contractor's right to proceed, the resulting damage will consist of liquidated damages until such reasonable time as may be required for final

completion of the work together with any increased costs occasioned the PHA in completing the work.

- (c) If the PHA does not terminate the Contractor's right to proceed, the resulting damage will consist of liquidated damages until the work is completed or accepted.

34. Termination for Convenience

- (a) The Contracting Officer may terminate this contract in whole, or in part, whenever the Contracting Officer determines that such termination is in the best interest of the PHA. Any such termination shall be effected by delivery to the Contractor of a Notice of Termination specifying the extent to which the performance of the work under the contract is terminated, and the date upon which such termination becomes effective.
- (b) If the performance of the work is terminated, either in whole or in part, the PHA shall be liable to the Contractor for reasonable and proper costs resulting from such termination upon the receipt by the PHA of a properly presented claim setting out in detail: (1) the total cost of the work performed to date of termination less the total amount of contract payments made to the Contractor; (2) the cost (including reasonable profit) of settling and paying claims under subcontracts and material orders for work performed and materials and supplies delivered to the site, payment for which has not been made by the PHA to the Contractor or by the Contractor to the subcontractor or supplier; (3) the cost of preserving and protecting the work already performed until the PHA or assignee takes possession thereof or assumes responsibility therefore; (4) the actual or estimated cost of legal and accounting services reasonably necessary to prepare and present the termination claim to the PHA; and (5) an amount constituting a reasonable profit on the value of the work performed by the Contractor.
- (c) The Contracting Officer will act on the Contractor's claim within days (60 days unless otherwise indicated) of receipt of the Contractor's claim.
- (d) Any disputes with regard to this clause are expressly made subject to the provisions of the Disputes clause of this contract.

35. Assignment of Contract

The Contractor shall not assign or transfer any interest in this contract; except that claims for monies due or to become due from the PHA under the contract may be assigned to a bank, trust company, or other financial institution. Such assignments of claims shall only be made with the written concurrence of the Contracting Officer. If the Contractor is a partnership, this contract shall inure to the benefit of the surviving or remaining member(s) of such partnership as approved by the Contracting Officer.

36. Insurance

- (a) Before commencing work, the Contractor and each subcontractor shall furnish the PHA with certificates of insurance showing the following insurance is in force and will insure all operations under the Contract:
- (1) Workers' Compensation, in accordance with state or Territorial Workers' Compensation laws.
 - (2) Commercial General Liability with a combined single limit for bodily injury and property damage of not less than \$ _____ [Contracting Officer insert amount]

per occurrence to protect the Contractor and each subcontractor against claims for bodily injury or death and damage to the property of others. This shall cover the use of all equipment, hoists, and vehicles on the site(s) not covered by Automobile Liability under (3) below. If the Contractor has a "claims made" policy, then the following additional requirements apply: the policy must provide a "retroactive date" which must be on or before the execution date of the Contract; and the extended reporting period may not be less than five years following the completion date of the Contract.

- (3) Automobile Liability on owned and non-owned motor vehicles used on the site(s) or in connection therewith for a combined single limit for bodily injury and property damage of not less than \$ _____ [Contracting Officer insert amount] per occurrence.
- (b) Before commencing work, the Contractor shall furnish the PHA with a certificate of insurance evidencing that Builder's Risk (fire and extended coverage) Insurance on all work in place and/or materials stored at the building site(s), including foundations and building equipment, is in force. The Builder's Risk Insurance shall be for the benefit of the Contractor and the PHA as their interests may appear and each shall be named in the policy or policies as an insured. The Contractor in installing equipment supplied by the PHA shall carry insurance on such equipment from the time the Contractor takes possession thereof until the Contract work is accepted by the PHA. The Builder's Risk Insurance need not be carried on excavations, piers, footings, or foundations until such time as work on the superstructure is started. It need not be carried on landscape work. Policies shall furnish coverage at all times for the full cash value of all completed construction, as well as materials in place and/or stored at the site(s), whether or not partial payment has been made by the PHA. The Contractor may terminate this insurance on buildings as of the date taken over for occupancy by the PHA. The Contractor is not required to carry Builder's Risk Insurance for modernization work which does not involve structural alterations or additions and where the PHA's existing fire and extended coverage policy can be endorsed to include such work.
- (c) All insurance shall be carried with companies which are financially responsible and admitted to do business in the State in which the project is located. If any such insurance is due to expire during the construction period, the Contractor (including subcontractors, as applicable) shall not permit the coverage to lapse and shall furnish evidence of coverage to the Contracting Officer. All certificates of insurance, as evidence of coverage, shall provide that no coverage may be canceled or non-renewed by the insurance company until at least 30 days prior written notice has been given to the Contracting Officer.

37. Subcontracts

- (a) Definitions. As used in this contract -
- (1) "Subcontract" means any contract, purchase order, or other purchase agreement, including modifications and change orders to the foregoing, entered into by a subcontractor to furnish supplies, materials, equipment, and services for the performance of the prime contract or a subcontract.

(2) "Subcontractor" means any supplier, vendor, or firm that furnishes supplies, materials, equipment, or services to or for the Contractor or another subcontractor.

- (b) The Contractor shall not enter into any subcontract with any subcontractor who has been temporarily denied participation in a HUD program or who has been suspended or debarred from participating in contracting programs by any agency of the United States Government or of the state in which the work under this contract is to be performed.
- (c) The Contractor shall be as fully responsible for the acts or omissions of its subcontractors, and of persons either directly or indirectly employed by them as for the acts or omissions of persons directly employed by the Contractor.
- (d) The Contractor shall insert appropriate clauses in all subcontracts to bind subcontractors to the terms and conditions of this contract insofar as they are applicable to the work of subcontractors.
- (e) Nothing contained in this contract shall create any contractual relationship between any subcontractor and the PHA or between the subcontractor and HUD.

38. Subcontracting with Small and Minority Firms, Women's Business Enterprise, and Labor Surplus Area Firms

The Contractor shall take the following steps to ensure that, whenever possible, subcontracts are awarded to small business firms, minority firms, women's business enterprises, and labor surplus area firms:

- (a) Placing qualified small and minority businesses and women's business enterprises on solicitation lists;
- (b) Ensuring that small and minority businesses and women's business enterprises are solicited whenever they are potential sources;
- (c) Dividing total requirements, when economically feasible, into smaller tasks or quantities to permit maximum participation by small and minority businesses and women's business enterprises;
- (d) Establishing delivery schedules, where the requirements of the contract permit, which encourage participation by small and minority businesses and women's business enterprises; and
- (e) Using the services and assistance of the U.S. Small Business Administration, the Minority Business Development Agency of the U.S. Department of Commerce, and State and local governmental small business agencies.

39. Equal Employment Opportunity

During the performance of this contract, the Contractor agrees as follows:

- (a) The Contractor shall not discriminate against any employee or applicant for employment because of race, color, religion, sex, national origin, or handicap.
- (b) The Contractor shall take affirmative action to ensure that applicants are employed, and that employees are treated during employment without regard to their race, color, religion, sex, national origin, or handicap. Such action shall include, but not be limited to, (1) employment, (2) upgrading, (3) demotion, (4) transfer, (5) recruitment or recruitment advertising, (6) layoff or termination, (7) rates of pay or other forms of compensation, and (8) selection for training, including apprenticeship.

- (c) The Contractor shall post in conspicuous places available to employees and applicants for employment the notices to be provided by the Contracting Officer that explain this clause.
- (d) The Contractor shall, in all solicitations or advertisements for employees placed by or on behalf of the Contractor, state that all qualified applicants will receive consideration for employment without regard to race, color, religion, sex, national origin, or handicap.
- (e) The Contractor shall send, to each labor union or representative of workers with which it has a collective bargaining agreement or other contract or understanding, the notice to be provided by the Contracting Officer advising the labor union or workers' representative of the Contractor's commitments under this clause, and post copies of the notice in conspicuous places available to employees and applicants for employment.
- (f) The Contractor shall comply with Executive Order 11246, as amended, and the rules, regulations, and orders of the Secretary of Labor.
- (g) The Contractor shall furnish all information and reports required by Executive Order 11246, as amended, Section 503 of the Rehabilitation Act of 1973, as amended, and by rules, regulations, and orders of the Secretary of Labor, or pursuant thereto. The Contractor shall permit access to its books, records, and accounts by the Secretary of Labor for purposes of investigation to ascertain compliance with such rules, regulations, and orders.
- (h) In the event of a determination that the Contractor is not in compliance with this clause or any rule, regulation, or order of the Secretary of Labor, this contract may be canceled, terminated, or suspended in whole or in part, and the Contractor may be declared ineligible for further Government contracts, or Federally assisted construction contracts under the procedures authorized in Executive Order 11246, as amended. In addition, sanctions may be imposed and remedies invoked against the Contractor as provided in Executive Order 11246, as amended, the rules, regulations, and orders of the Secretary of Labor, or as otherwise provided by law.
- (i) The Contractor shall include the terms and conditions of this clause in every subcontract or purchase order unless exempted by the rules, regulations, or orders of the Secretary of Labor issued under Executive Order 11246, as amended, so that these terms and conditions will be binding upon each subcontractor or vendor. The Contractor shall take such action with respect to any subcontract or purchase order as the Secretary of Housing and Urban Development or the Secretary of Labor may direct as a means of enforcing such provisions, including sanctions for noncompliance; provided that if the Contractor becomes involved in, or is threatened with, litigation with a subcontractor or vendor as a result of such direction, the Contractor may request the United States to enter into the litigation to protect the interests of the United States.
- (j) Compliance with the requirements of this clause shall be to the maximum extent consistent with, but not in derogation of, compliance with section 7(b) of the Indian Self-Determination and Education Assistance Act and the Indian Preference clause of this contract.
- 40. Employment, Training, and Contracting Opportunities for Low-Income Persons, Section 3 of the Housing and Urban Development Act of 1968.**
- (a) The work to be performed under this contract is subject to the requirements of section 3 of the Housing and Urban Development Act of 1968, as amended, 12 U.S.C. 1701u (section 3). The purpose of section 3 is to ensure that employment and other economic opportunities generated by HUD assistance or HUD-assisted projects covered by section 3, shall, to the greatest extent feasible, be directed to low- and very low-income persons, particularly persons who are recipients of HUD assistance for housing.
- (b) The parties to this contract agree to comply with HUD's regulations in 24 CFR Part 135, which implement section 3. As evidenced by their execution of this contract, the parties to this contract certify that they are under no contractual or other impediment that would prevent them from complying with the Part 135 regulations.
- (c) The contractor agrees to send to each labor organization or representative of workers with which the contractor has a collective bargaining agreement or other understanding, if any, a notice advising the labor organization or workers' representative of the contractor's commitments under this section 3 clause, and will post copies of the notice in conspicuous places at the work site where both employees and applicants for training and employment positions can see the notice. The notice shall describe the section 3 preference, shall set forth minimum number and job titles subject to hire, availability of apprenticeship and training positions, the qualifications for each; and the name and location of the person(s) taking applications for each of the positions; and the anticipated date the work shall begin.
- (d) The contractor agrees to include this section 3 clause in every subcontract subject to compliance with regulations in 24 CFR Part 135, and agrees to take appropriate action, as provided in an applicable provision of the subcontract or in this section 3 clause, upon a finding that the subcontractor is in violation of the regulations in 24 CFR Part 135. The contractor will not subcontract with any subcontractor where the contractor has notice or knowledge that the subcontractor has been found in violation of the regulations in 24 CFR Part 135.
- (e) The contractor will certify that any vacant employment positions, including training positions, that are filled (1) after the contractor is selected but before the contract is executed, and (2) with persons other than those to whom the regulations of 24 CFR Part 135 require employment opportunities to be directed, were not filled to circumvent the contractor's obligations under 24 CFR Part 135.
- (f) Noncompliance with HUD's regulations in 24 CFR Part 135 may result in sanctions, termination of this contract for default, and debarment or suspension from future HUD assisted contracts.
- (g) With respect to work performed in connection with section 3 covered Indian housing assistance, section 7(b) of the Indian Self-Determination and Education Assistance Act (25 U.S.C. 450e) also applies to the work to be performed under this contract. Section 7(b) requires that to the greatest extent feasible (i) preference and opportunities for training and employment shall be given to Indians, and (ii) preference in the award of contracts and subcontracts shall be given to Indian organizations and Indian-owned Economic Enterprises. Parties to this contract that are subject to the provisions of section 3 and section 7(b) agree to comply with section 3 to the maximum extent feasible, but not in derogation of compliance with section 7(b).

41. Interest of Members of Congress

No member of or delegate to the Congress of the United States of America shall be admitted to any share or part of this contract or to any benefit that may arise therefrom.

42. Interest of Members, Officers, or Employees and Former Members, Officers, or Employees

No member, officer, or employee of the PHA, no member of the governing body of the locality in which the project is situated, no member of the governing body of the locality in which the PHA was activated, and no other public official of such locality or localities who exercises any functions or responsibilities with respect to the project, shall, during his or her tenure, or for one year thereafter, have any interest, direct or indirect, in this contract or the proceeds thereof.

43. Limitations on Payments made to Influence Certain Federal Financial Transactions

- (a) The Contractor agrees to comply with Section 1352 of Title 31, United States Code which prohibits the use of Federal appropriated funds to pay any person for influencing or attempting to influence an officer or employee of any agency, a Member of Congress, and officer or employee of Congress, or an employee of a Member of Congress in connection with any of the following covered Federal actions: the awarding of any Federal contract; the making of any Federal grant; the making of any Federal loan; the entering into of any cooperative agreement; or the modification of any Federal contract, grant, loan, or cooperative agreement.
- (b) The Contractor further agrees to comply with the requirement of the Act to furnish a disclosure (OMB Standard Form LLL, Disclosure of Lobbying Activities) if any funds other than Federal appropriated funds (including profit or fee received under a covered Federal transaction) have been paid, or will be paid, to any person for influencing or attempting to influence an officer or employee of any agency, a Member of Congress, an officer or employee of Congress, or an employee of a Member of Congress in connection with a Federal contract, grant, loan, or cooperative agreement.

44. Royalties and Patents

The Contractor shall pay all royalties and license fees. It shall defend all suits or claims for infringement of any patent rights and shall save the PHA harmless from loss on account thereof; except that the PHA shall be responsible for all such loss when a particular design, process or the product of a particular manufacturer or manufacturers is specified and the Contractor has no reason to believe that the specified design, process, or product is an infringement. If, however, the Contractor has reason to believe that any design, process or product specified is an infringement of a patent, the Contractor shall promptly notify the Contracting Officer. Failure to give such notice shall make the Contractor responsible for resultant loss.

45. Examination and Retention of Contractor's Records

- (a) The PHA, HUD, or Comptroller General of the United States, or any of their duly authorized representatives shall, until 3 years after final payment under this contract, have access to and the right to examine any of the Contractor's directly pertinent books, documents, papers, or other records involving transactions related to this contract for the purpose of making audit, examination, excerpts, and transcriptions.
- (b) The Contractor agrees to include in first-tier subcontracts under this contract a clause substantially the same as paragraph (a) above. "Subcontract," as used in this clause, excludes purchase orders not exceeding \$10,000.
- (c) The periods of access and examination in paragraphs (a) and (b) above for records relating to (1) appeals under the Disputes clause of this contract, (2) litigation or settlement of claims arising from the performance of this contract, or (3) costs and expenses of this contract to which the PHA, HUD, or Comptroller General or any of their duly authorized representatives has taken exception shall continue until disposition of such appeals, litigation, claims, or exceptions.

46. Labor Standards - Davis-Bacon and Related Acts

If the total amount of this contract exceeds \$2,000, the Federal labor standards set forth in the clause below shall apply to the development or construction work to be performed under the contract.

- (a) Minimum Wages.
 - (1) All laborers and mechanics employed under this contract in the development or construction of the project(s) involved will be paid unconditionally and not less often than once a week, and without subsequent deduction or rebate on any account (except such payroll deductions as are permitted by regulations issued by the Secretary of Labor under the Copeland Act (29 CFR Part 3)), the full amount of wages and bona fide fringe benefits (or cash equivalents thereof) due at time of payment computed at rates not less than those contained in the wage determination of the Secretary of Labor which is attached hereto and made a part hereof, regardless of any contractual relationship which may be alleged to exist between the Contractor and such laborers and mechanics. Contributions made or costs reasonably anticipated for bona fide fringe benefits under Section 1(b)(2) of the Davis-Bacon Act on behalf of laborers or mechanics are considered wages paid to such laborers or mechanics, subject to the provisions of 29 CFR 5.5(a)(1)(iv); also, regular contributions made or costs incurred for more than a weekly period (but not less often than quarterly) under plans, funds, or programs which cover the regular weekly period, are deemed to be constructively made or incurred during such weekly period. Such laborers and mechanics shall be paid the appropriate wage rate and fringe benefits in the wage determination for the classification of work actually performed, without regard to skill, except as provided in 29 CFR 5.5(a)(4). Laborers or mechanics performing work in more than one classification may be compensated at the rate specified for each classification for the time actually worked therein; provided, that the employer's payroll records accurately set forth the time spent in each classification in which work is performed. The wage determination (including any additional classification and wage rates conformed under 29 CFR 5.5(a)(1)(ii) and the Davis-Bacon poster (WH-1321) shall

be posted at all times by the Contractor and its subcontractors at the site of the work in a prominent and accessible place where it can be easily seen by the workers.

- (2) (i) Any class of laborers or mechanics, including helpers, which is not listed in the wage determination and which is to be employed under the contract shall be classified in conformance with the wage determination. HUD shall approve an additional classification and wage rate and fringe benefits therefor only when all the following criteria have been met: (A) The work to be performed by the classification requested is not performed by a classification in the wage determination; and (B) The classification is utilized in the area by the construction industry; and (C) The proposed wage rate, including any bona fide fringe benefits, bears a reasonable relationship to the wage rates contained in the wage determination.
- (ii) If the Contractor and the laborers and mechanics to be employed in the classification (if known), or their representatives, and HUD or its designee agree on the classification and wage rate (including the amount designated for fringe benefits where appropriate), a report of the action taken shall be sent by HUD or its designee to the Administrator of the Wage and Hour Division, Employee Standards Administration, U.S. Department of Labor, Washington, DC 20210. The Administrator, or an authorized representative, will approve, modify, or disapprove every additional classification action within 30 days of receipt and so advise HUD or its designee or will notify HUD or its designee within the 30-day period that additional time is necessary.
- (iii) In the event the Contractor, the laborers or mechanics to be employed in the classification or their representatives, and HUD or its designee do not agree on the proposed classification and wage rate (including the amount designated for fringe benefits, where appropriate), HUD or its designee shall refer the questions, including the views of all interested parties and the recommendation of HUD or its designee, to the Administrator of the Wage and Hour Division for determination. The Administrator, or an authorized representative, will issue a determination within 30 days of receipt and so advise HUD or its designee or will notify HUD or its designee within the 30-day period that additional time is necessary.
- (iv) The wage rate (including fringe benefits where appropriate) determined pursuant to subparagraphs (a)(2)(ii) or (iii) of this clause shall be paid to all workers performing work in the classification under this contract from the first day on which work is performed in classification.
- (3) Whenever the minimum wage rate prescribed in the contract for a class of laborers or mechanics includes a fringe benefit which is not expressed as an hourly rate, the Contractor shall either pay the benefit as stated in the wage determination or shall pay another bona fide fringe benefit or an hourly cash equivalent thereof.
- (4) If the Contractor does not make payments to a trustee or other third person, the Contractor may consider as part of the wages of any laborer or mechanic the

amount of any costs reasonably anticipated in providing bona fide fringe benefits under a plan or program; provided, that the Secretary of Labor has found, upon the written request of the Contractor, that the applicable standards of the Davis-Bacon Act have been met. The Secretary of Labor may require the Contractor to set aside in a separate account assets for the meeting of obligations under the plan or program.

- (b) Withholding of funds. HUD or its designee shall, upon its own action or upon written request of an authorized representative of the Department of Labor, withhold or cause to be withheld from the Contractor under this contract or any other Federal contract with the same prime Contractor, or any other Federally-assisted contract subject to Davis-Bacon prevailing wage requirements, which is held by the same prime Contractor, so much of the accrued payments or advances as may be considered necessary to pay laborers and mechanics, including apprentices, trainees, and helpers, employed by the Contractor or any subcontractor the full amount of wages required by the contract. In the event of failure to pay any laborer or mechanic, including any apprentice, trainee, or helper, employed or working in the construction or development of the project, all or part of the wages required by the contract, HUD or its designee may, after written notice to the Contractor, take such action as may be necessary to cause the suspension of any further payment, advance, or guarantee of funds until such violations have ceased. HUD or its designee may, after written notice to the Contractor, disburse such amounts withheld for and on account of the Contractor or subcontractor to the respective employees to whom they are due.
- (c) Payrolls and basic records.
- (1) Payrolls and basic records relating thereto shall be maintained by the Contractor during the course of the work and preserved for a period of three years thereafter for all laborers and mechanics working in the construction or development of the project. Such records shall contain the name, address, and social security number of each such worker, his or her correct classification, hourly rates of wages paid (including rates of contributions or costs anticipated for bona fide fringe benefits or cash equivalents thereof of the types described in section 1(b)(2)(B) of the Davis-Bacon Act), daily and weekly number of hours worked, deductions made, and actual wages paid. Whenever the Secretary of Labor has found, under 29 CFR 5.5(a)(1)(iv), that the wages of any laborer or mechanic include the amount of costs reasonably anticipated in providing benefits under a plan or program described in section 1(b)(2)(B) of the Davis-Bacon Act, the Contractor shall maintain records which show that the commitment to provide such benefits is enforceable, that the plan or program is financially responsible, and that the plan or program has been communicated in writing to the laborers or mechanics affected, and records which show the costs anticipated or the actual cost incurred in providing such benefits. Contractors employing apprentices or trainees under approved programs shall maintain written evidence of the registration of apprenticeship programs and certification of trainee programs, the registration of the apprentices and trainees, and the ratios and wage rates prescribed in the applicable programs.

- (2) (i) The Contractor shall submit weekly for each week in which any contract work is performed a copy of all payrolls to the Contracting Officer for transmission to HUD or its designee. The payrolls submitted shall set out accurately and completely all of the information required to be maintained under subparagraph (c)(1) of this clause. This information may be submitted in any form desired. Optional Form WH-347 (Federal Stock Number 029-005-00014-1) is available for this purpose and may be purchased from the Superintendent of Documents, U.S. Government Printing Office, Washington, D.C. 20402. The Contractor is responsible for the submission of copies of payrolls by all subcontractors. (Approved by the Office of Management and Budget under OMB Control Number 1214-0149.)
- (ii) Each payroll submitted shall be accompanied by a "Statement of Compliance," signed by the Contractor or subcontractor or his or her agent who pays or supervises the payment of the persons employed under the contract and shall certify the following:
- (A) That the payroll for the payroll period contains the information required to be maintained under paragraph (c) (1) of this clause and that such information is correct and complete;
- (B) That each laborer or mechanic (including each helper, apprentice, and trainee) employed on the contract during the payroll period has been paid the full weekly wages earned, without rebate, either directly or indirectly, and that no deductions have been made either directly or indirectly from the full wages earned, other than permissible deductions as set forth in 29 CFR Part 3; and
- (C) That each laborer or mechanic has been paid not less than the applicable wage rates and fringe benefits or cash equivalents for the classification of work performed, as specified in the applicable wage determination incorporated into the contract.
- (iii) The weekly submission of a properly executed certification set forth on the reverse side of Optional Form WH-347 shall satisfy the requirements for submission of the "Statement of Compliance" required by subparagraph (c)(2)(ii) of this clause.
- (iv) The falsification of any of the above certifications may subject the Contractor or subcontractor to civil or criminal prosecution under Section 1001 of Title 18 and Section 3729 of Title 31 of the United States Code.
- (3) The Contractor or subcontractor shall make the records required under subparagraph (c)(1) available for inspection, copying, or transcription by authorized representatives of HUD or its designee, the Contracting Officer, or the Department of Labor and shall permit such representatives to interview employees during working hours on the job. If the Contractor or subcontractor fails to submit the required records or to make them available, HUD or its designee may, after written notice to the Contractor, take such action as may be necessary to cause the suspension of any further payment, advance, or guarantee of funds. Furthermore, failure to submit the required records upon request or to

make such records available may be grounds for debarment action pursuant to 29 CFR 5.12.

- (d) (1) Apprentices. Apprentices will be permitted to work at less than the predetermined rate for the work they performed when they are employed pursuant to and individually registered in a bona fide apprenticeship program registered with the U.S. Department of Labor, Employment and Training Administration, Office of Apprenticeship and Training, Employer and Labor Services (OATELS), or with a State Apprenticeship Agency recognized by OATELS, or if a person is employed in his or her first 90 days of probationary employment as an apprentice in such an apprenticeship program, who is not individually registered in the program, but who has been certified by OATELS or a State Apprenticeship Agency (where appropriate) to be eligible for probationary employment as an apprentice. The allowable ratio of apprentices to journeymen on the job site in any craft classification shall not be greater than the ratio permitted to the Contractor as to the entire work force under the registered program. Any worker listed on a payroll at an apprentice wage rate, who is not registered or otherwise employed as stated in this paragraph, shall be paid not less than the applicable wage rate on the wage determination for the classification of work actually performed. In addition, any apprentice performing work on the job site in excess of the ratio permitted under the registered program shall be paid not less than the applicable wage rate on the wage determination for the work actually performed. Where a contractor is performing construction on a project in a locality other than that in which its program is registered, the ratios and wage rates (expressed in percentages of the journeyman's hourly rate) specified in the Contractor's or subcontractor's registered program shall be observed. Every apprentice must be paid at not less than the rate specified in the registered program for the apprentice's level of progress, expressed as a percentage of the journeyman hourly rate specified in the applicable wage determination. Apprentices shall be paid fringe benefits in accordance with the provisions of the apprenticeship program. If the apprenticeship program does not specify fringe benefits, apprentices must be paid the full amount of fringe benefits listed on the wage determination for the applicable classification. If the Administrator of the Wage and Hour Division determines that a different practice prevails for the applicable apprentice classification, fringes shall be paid in accordance with that determination. In the event OATELS, or a State Apprenticeship Agency recognized by OATELS, withdraws approval of an apprenticeship program, the Contractor will no longer be permitted to utilize apprentices at less than the applicable predetermined rate for the work performed until an acceptable program is approved.
- (2) Trainees. Except as provided in 29 CFR 5.16, trainees will not be permitted to work at less than the predetermined rate for the work performed unless they are employed pursuant to and individually registered in a program which has received prior approval, evidenced by formal certification by the U.S. Department of Labor, Employment and Training Administration. The ratio of trainees to journeymen on the job site shall not be greater than permitted under

the plan approved by the Employment and Training Administration. Every trainee must be paid at not less than the rate specified in the approved program for the trainee's level of progress, expressed as a percentage of the journeyman hourly rate specified in the applicable wage determination. Trainees shall be paid fringe benefits in accordance with the provisions of the trainee program. If the trainee program does not mention fringe benefits, trainees shall be paid the full amount of fringe benefits listed in the wage determination unless the Administrator of the Wage and Hour Division determines that there is an apprenticeship program associated with the corresponding journeyman wage rate in the wage determination which provides for less than full fringe benefits for apprentices. Any employee listed on the payroll at a trainee rate who is not registered and participating in a training plan approved by the Employment and Training Administration shall be paid not less than the applicable wage rate in the wage determination for the classification of work actually performed. In addition, any trainee performing work on the job site in excess of the ratio permitted under the registered program shall be paid not less than the applicable wage rate in the wage determination for the work actually performed. In the event the Employment and Training Administration withdraws approval of a training program, the Contractor will no longer be permitted to utilize trainees at less than the applicable predetermined rate for the work performed until an acceptable program is approved.

- (3) Equal employment opportunity. The utilization of apprentices, trainees, and journeymen under this clause shall be in conformity with the equal employment opportunity requirements of Executive Order 11246, as amended, and 29 CFR Part 30.
- (e) Compliance with Copeland Act requirements. The Contractor shall comply with the requirements of 29 CFR Part 3, which are hereby incorporated by reference in this contract.
- (f) Contract termination; debarment. A breach of this contract clause may be grounds for termination of the contract and for debarment as a Contractor and a subcontractor as provided in 29 CFR 5.12.
- (g) Compliance with Davis-Bacon and related Act requirements. All rulings and interpretations of the Davis-Bacon and related Acts contained in 29 CFR Parts 1, 3, and 5 are herein incorporated by reference in this contract.
- (h) Disputes concerning labor standards. Disputes arising out of the labor standards provisions of this clause shall not be subject to the general disputes clause of this contract. Such disputes shall be resolved in accordance with the procedures of the Department of Labor set forth in 29 CFR Parts 5, 6, and 7. Disputes within the meaning of this clause include disputes between the Contractor (or any of its subcontractors) and the PHA, HUD, the U.S. Department of Labor, or the employees or their representatives.
- (i) Certification of eligibility.
 - (1) By entering into this contract, the Contractor certifies that neither it (nor he or she) nor any person or firm who has an interest in the Contractor's firm is a person or firm ineligible to be awarded contracts by the United States Government by virtue of section 3(a) of the Davis-Bacon Act or 29 CFR 5.12(a)(1).

- (2) No part of this contract shall be subcontracted to any person or firm ineligible for award of a United States Government contract by virtue of section 3(a) of the Davis-Bacon Act or 29 CFR 5.12(a)(1).
 - (3) The penalty for making false statements is prescribed in the U. S. Criminal Code, 18 U.S.C. 1001.
- (j) Contract Work Hours and Safety Standards Act. As used in this paragraph, the terms "laborers" and "mechanics" include watchmen and guards.
- (1) Overtime requirements. No contractor or subcontractor contracting for any part of the contract work which may require or involve the employment of laborers or mechanics, including watchmen and guards, shall require or permit any such laborer or mechanic in any workweek in which the individual is employed on such work to work in excess of 40 hours in such workweek unless such laborer or mechanic receives compensation at a rate not less than one and one-half times the basic rate of pay for all hours worked in excess of 40 hours in such workweek.
 - (2) Violation; liability for unpaid wages; liquidated damages. In the event of any violation of the provisions set forth in subparagraph (j)(1) of this clause, the Contractor and any subcontractor responsible therefor shall be liable for the unpaid wages. In addition, such Contractor and subcontractor shall be liable to the United States (in the case of work done under contract for the District of Columbia or a territory, to such District or to such territory), for liquidated damages. Such liquidated damages shall be computed with respect to each individual laborer or mechanic (including watchmen and guards) employed in violation of the provisions set forth in subparagraph (j)(1) of this clause, in the sum of \$10 for each calendar day on which such individual was required or permitted to work in excess of the standard workweek of 40 hours without payment of the overtime wages required by provisions set forth in subparagraph (j)(1) of this clause.
 - (3) Withholding for unpaid wages and liquidated damages. HUD or its designee shall upon its own action or upon written request of an authorized representative of the Department of Labor withhold or cause to be withheld, from any moneys payable on account of work performed by the Contractor or subcontractor under any such contract or any Federal contract with the same prime Contractor, or any other Federally-assisted contract subject to the Contract Work Hours and Safety Standards Act, which is held by the same prime Contractor, such sums as may be determined to be necessary to satisfy any liabilities of such Contractor or subcontractor for unpaid wages and liquidated damages as provided in the provisions set forth in subparagraph (j)(2) of this clause.
- (k) Subcontracts. The Contractor or subcontractor shall insert in any subcontracts all the provisions contained in this clause, and such other clauses as HUD or its designee may by appropriate instructions require, and also a clause requiring the subcontractors to include these provisions in any lower tier subcontracts. The prime Contractor shall be responsible for the compliance by any subcontractor or lower tier subcontractor with all these provisions.

47. Non-Federal Prevailing Wage Rates

- (a) Any prevailing wage rate (including basic hourly rate and any fringe benefits), determined under State or tribal law to be prevailing, with respect to any employee in any trade or position employed under the contract, is inapplicable to the contract and shall not be enforced against the Contractor or any subcontractor, with respect to employees engaged under the contract whenever such non-Federal prevailing wage rate exceeds:
 - (1) The applicable wage rate determined by the Secretary of Labor pursuant to the Davis-Bacon Act (40 U.S.C. 3141 et seq.) to be prevailing in the locality with respect to such trade;
- (b) An applicable apprentice wage rate based thereon specified in an apprenticeship program registered with the U.S. Department of Labor (DOL) or a DOL-recognized State Apprenticeship Agency; or
- (c) An applicable trainee wage rate based thereon specified in a DOL-certified trainee program.

48. Procurement of Recovered Materials.

- (a) In accordance with Section 6002 of the Solid Waste Disposal Act, as amended by the Resource Conservation and Recovery Act, the Contractor shall procure items designated in guidelines of the Environmental Protection Agency (EPA) at 40 CFR Part 247 that contain the highest percentage of recovered materials practicable, consistent with maintaining a satisfactory level of competition. The Contractor shall procure items designated in the EPA guidelines that contain the highest percentage of recovered materials practicable unless the Contractor determines that such items: (1) are not reasonably available in a reasonable period of time; (2) fail to meet reasonable performance standards, which shall be determined on the basis of the guidelines of the National Institute of Standards and Technology, if applicable to the item; or (3) are only available at an unreasonable price.
- (b) Paragraph (a) of this clause shall apply to items purchased under this contract where: (1) the Contractor purchases in excess of \$10,000 of the item under this contract; or (2) during the preceding Federal fiscal year, the Contractor: (i) purchased any amount of the items for use under a contract that was funded with Federal appropriations and was with a Federal agency or a State agency or agency of a political subdivision of a State; and (ii) purchased a total of in excess of \$10,000 of the item both under and outside that contract.

OHA Insurance Requirements for Contractors

Oakland Housing Authority

INSURANCE REQUIREMENTS

Consultant/Contractor/Organization shall procure and maintain for the duration of the Contract insurance against claims for injuries to persons or damages to property which may arise from or in connection with the performance of the work hereunder by the Consultant/Contractor/Organizer, its agents, representatives, or employees.

Minimum Scope of Insurance

Coverage shall be as least as board as:

1. Insurance Services Office Commercial General Liability coverage (occurrence Form CG 0001).
2. Insurance Services Office Form Number CA 0001 covering Automobile Liability, Code 1 (any auto).
3. Workers' Compensation insurance as required by the State of California and Employer's Liability Insurance.

Minimum Limits of Insurance

Consultant/Contractor/Organizers shall maintain limits no less than:

1. General Liability: **\$1,000,000** per occurrence for bodily injury, personal injury and property damage. If Commercial General Liability Insurance or other form with a general aggregate limit is used, either the general aggregate limit shall apply separately to this project/location or the general aggregate limit shall be twice the required occurrence limit.
(Including operations, products and completed operations, as applicable.)
2. Automobile Liability: **\$1,000,000** per accident for bodily injury and property damage.
3. Workers' Compensation and **\$1,000,000** per accident for bodily injury and Employer's Liability: property damage.

Deductible and Self-Insured Retentions

Any deductibles or self-insured retentions must be declared to and approved by the Authority. At the option of the Authority; the insurer shall reduce or eliminate such deductibles or self-insured retentions as respects the Authority, its officers, officials, employees and volunteers; or the Consultant/Contractor/Organizers shall provide a financial guarantee satisfactory to the Authority guaranteeing payment of losses and related investigations, claim administration and defense expenses.

Oakland Housing Authority

Other Insurance Provisions

The commercial general liability is to contain, or be endorsed to contain, the following provisions.

1. The Authority, its commissioners, members, officers, agents, employees and volunteers are to be covered as insureds as respects: liability arising out of work or operations performed by or on behalf of the Consultant/Contractor/Organizer; or automobiles owned, leased, hired or borrowed by the Consultant/Contractor/Organizer.
2. For any claims related to this project, the Consultant's/Contractor's/Organizer's insurance coverage shall be primary insurance as respects the Authority, its officers, officials, employees and volunteers. Any insurance or self-insurance maintained by the Authority, its commissioners, members, officers, agents, employees or volunteers shall be excess of the Consultant's/Contractor's/Organizer's insurance and shall not contribute with it.
3. Each insurance policy required by this clause shall be endorsed to state that coverage shall not be canceled by either party, except after (30) days' prior written notice by certified mail, returned receipt requested, has been given to the Authority.
4. Any failure to comply with reporting provisions of the policies shall not affect coverage provided to the Authority, its commissioners, members, officers, agents, employees and volunteers.
5. Coverage shall not extend to any indemnity coverage for the active negligence of the additional insured in any case where an agreement to indemnify the additional insured would be invalid under Subdivision (b) of Section 2782 of the Civil Code.

Acceptability of Insurers

Insurance is to be placed with insurers with a current A.M. Best's rating of no less than A:VI, unless otherwise acceptable to the Authority.

Verification of Coverage

Consultant/Contractor shall furnish the Authority with certificates of insurance and with original endorsements evidencing coverage required by this clause. All certificates and endorsements are to be received and approved by the Authority before work commences. The Authority reserves the right to require complete, certified copies of all required insurance policies, including endorsements affecting the coverage required by these specifications at any time.

Oakland Housing Authority

**Oakland Housing Authority shall be named as an additionally insured on all policies, certificate of insurance and endorsements.*

Vendor Protests and Claims Procedures

VENDOR PROTESTS AND CLAIMS PROCEDURES

VENDOR PROTESTS AND CLAIMS PROCEDURES

The following are the definitions of terms used in this section.

Definitions:

<i>OHA:</i>	The abbreviation for the Housing Authority of the City of Oakland, California, commonly known as the Oakland Housing Authority.
<i>Claim:</i>	The assertion of facts which serves as the basis for a demand of payment, reimbursement, or compensation believed by the vendor to be due the vendor. The claim must be submitted in writing, by the affected vendor, on the "Notice of Protest or Claim" form (Form MMO9501; hereinafter referred to as "Notice" or "the Notice") furnished by OHA (form attached).
<i>Contract Award Date:</i>	Date of Board Approval (if applicable) or Purchase Order Date
<i>Contracting Officer:</i>	The Executive Director of OHA or the person designated by the Executive Director in writing.
<i>Finding of Fact:</i>	Results of investigation of information presented.
<i>Posted Website Date:</i>	Date When Information was Posted on Website
<i>Protest:</i>	A written complaint about, or an objection to, an administrative or procurement action or decision by OHA. The protest must be submitted, including any and all facts on which it is based, by the affected vendor, on the "Notice of Protest or Claim" form (MMO-9501) provided by OHA (form attached).
<i>Response to Solicitation:</i>	The vendor's written bid, quotation or proposal submitted in response to OHA's call for bids, quotations or request for proposals.
<i>Vendor:</i>	The person or firm that is involved in bidding, proposing, or quoting on an OHA material or service requirement, or has contracted with OHA to provide material or perform a service, or a person who has an interest in such matters.

Who May Submit A Protest or Claim:

Any person or entity that meets the definition of vendor as referenced above may submit a protest or claim.

This procedure applies to bidding procedures for amounts above the 'Small Purchase' threshold (> \$100,000). For Small Purchases (\$2,000 - \$100,000), all complaints, protests, or claims will be referred to the Deputy Executive Director for resolution.

Vendor protests, claims, or disputes shall be resolved using the following procedures:

A. Protests After the Bid, Quote, or Proposal Opening, but Prior to Award of Contract:

1. Any protest or claim must be submitted in writing by the vendor on the Notice of Protest or Claim form. The form, along with any supporting documents, must be sent by certified, registered or overnight mail or delivered by a reputable delivery service with a delivery receipt to the following address:

CCGS (Contract Compliance & General Services)
Oakland Housing Authority
1801 Harrison Street
Oakland, CA 94612

2. ***Under the Competitive (Sealed) Bids Process:*** Vendor must submit a written Notice of Protest or Claim to the Authority's Contracting Officer within ***five business days*** of the *bid opening date*.

Under the RFPs (Request for Proposals) Process: For RFPs where there is no bid opening, Vendor must submit a written Notice of Protest or Claim to the Authority's Contracting Officer within ***five business days*** of the date on which the name of the Contractor has been released after the completion of the evaluation process or the "Posted Website Date". The 'Posted Website Date' is the date that CCGS will post the selected Contractor as a result of the evaluation panel member decision. Please note that the **selection of the final Contractor is contingent upon final board approval (if applicable) and/or all required documents have been received.**

3. All protests or claims must contain, at a minimum, the following to be considered valid:

- The Name(s), address(es), telephone and fax number(s), email address(es) and title(s) of the person(s) filing the protest or claims;
- The name of the company and the address, telephone and fax number(s) and email addresses thereof (if different from above);
- The title and number of the solicitation (i.e., bid, proposal and quotation);
- The signature of the vendor or agent representing the vendor;
- A detailed description of the grounds for the protest or claim, and identification of the specific statutory or regulatory provision(s) that the OHA contracting personnel or other relevant employees allegedly have violated;
- A detailed statement of all the relevant fact (including how the vendor was aggrieved or prejudiced against) with any supporting documentation; and,
- The type of relief and redress the vendor is seeking.

4. Immediately upon receipt of the vendor's notice, the Contracting Officer shall send the vendor an acknowledgement for receipt of the Notice. The Oakland Housing Authority acknowledgement shall indicate if the Notice was filed within the required time period. A late notice is not eligible for consideration under this procedure and will be rejected

5. The vendor's protest, along with the tabulation sheet, scope of work of the solicitation, copies of responses received, and any other relevant documents, shall be provided to the Contracting Officer. The Contracting Officer shall review the vendor's protest and the circumstances and prepare a "Finding of Fact."

6. Based upon the "Finding of Fact", the Contracting Officer may take any of the following actions or any other actions deemed to be appropriate and within the scope of statutory and regulatory requirements.

- (a) Determine that the protest is invalid.
- (b) Reject all responses to the solicitation.
- (c) Cancel or revise the solicitation.

The decision of the Contracting Officer shall be final.

B. Special Circumstances:

Board Approval: If the dollar amount of the lowest responsive, responsible bidder is above the amount threshold requiring approval by the Board of Commissioners, the Contracting Officer shall make a recommendation of action to the Board ratifying this finding.

C. OHA Recordkeeping Requirement:

OHA shall maintain a complete and detailed record of all protests and claims. The record shall include all pertinent correspondence, the written or recorded minutes of any meetings with the vendors making the protests or claims, and any information used in determining OHA's actions in the disposition of protests or claims.

NOTICE OF PROTEST OR CLAIM

All protests or claims must contain, at a minimum, the following to be considered valid:

- The Name(s), address(es), telephone and fax number(s), email address(es) and title(s) of the person(s) filing the protest or claims;
- The name of the company and the address, telephone and fax number(s) and email addresses thereof (if different from above);
- The title and number of the solicitation (i.e., bid, proposal and quotation);
- The signature of the vendor or agent representing the vendor;
- A detailed description of the grounds for the protest or claim, and identification of the specific statutory or regulatory provision(s) that the OHA contracting personnel or other relevant employees allegedly have violated;
- A detailed statement of all the relevant fact (including how the vendor was aggrieved or prejudiced against) with any supporting documentation; and,
- The type of relief and redress the vendor is seeking.

This form must be completed with additional applicable documents attached.

CLAIMANT INFORMATION			
Name of Claimant:		Date:	
Address:		Phone:	
Email:		Fax:	
COMPANY INFORMATION (if different from above)			
Name of Company:			
Address:		Phone:	
AGENT INFORMATION (if Agent Filing)			
Name of Agent:	Date:		
Address:		Phone:	
Email:		Fax:	

Referenced (if applicable):

Bid/RFP No.:	
Project Description:	
Purchase Order No.:	
Invoice No.:	

REASON FOR CLAIM OR PROTEST: *(Attach copies of detail documents if any)*

(OHA Use Only)

Date Received:	Contracting Officer:
Notification:	Filing Date:
Comments:	

Wage Determination - Davis-Bacon Wage Decision

"General Decision Number: CA20210018 01/22/2021

Superseded General Decision Number: CA20200018

State: California

Construction Types: Building, Heavy (Heavy and Dredging) and Highway

Counties: Alameda, Calaveras, Contra Costa, Fresno, Kings, Madera, Mariposa, Merced, Monterey, San Benito, San Francisco, San Joaquin, San Mateo, Santa Clara, Santa Cruz, Stanislaus and Tuolumne Counties in California.

BUILDING CONSTRUCTION PROJECTS; DREDGING PROJECTS (does not include hopper dredge work); HEAVY CONSTRUCTION PROJECTS (does not include water well drilling); HIGHWAY CONSTRUCTION PROJECTS

Note: Under Executive Order (EO) 13658, an hourly minimum wage of \$10.95 for calendar year 2021 applies to all contracts subject to the Davis-Bacon Act for which the contract is awarded (and any solicitation was issued) on or after January 1, 2015. If this contract is covered by the EO, the contractor must pay all workers in any classification listed on this wage determination at least \$10.95 per hour (or the applicable wage rate listed on this wage determination, if it is higher) for all hours spent performing on the contract in calendar year 2021. If this contract is covered by the EO and a classification considered necessary for performance of work on the contract does not appear on this wage determination, the contractor must pay workers in that classification at least the wage rate determined through the conformance process set forth in 29 CFR 5.5(a)(1)(ii) (or the EO minimum wage rate, if it is higher than the conformed wage rate). The EO minimum wage rate will be adjusted annually. Please note that this EO applies to the above-mentioned types of contracts entered into by the federal government that are subject to the Davis-Bacon Act itself, but it does not apply to contracts subject only to the Davis-Bacon Related Acts, including those set forth at 29 CFR 5.1(a)(2)-(60). Additional information on contractor requirements and worker protections under the EO is available at www.dol.gov/whd/govcontracts.

Modification Number	Publication Date
0	01/01/2021
1	01/08/2021
2	01/15/2021
3	01/22/2021

ALAMEDA COUNTY

Rates Fringes

Sound & Communications

Installer.....	\$ 45.50	3%+21.15
Technician.....	\$ 52.33	3%+21.15

SCOPE OF WORK: Including any data system whose only function is to transmit or receive information; excluding all other data systems or multiple systems which include control function or power supply; inclusion or exclusion of terminations and testings of conductors determined by their function; excluding fire alarm work when installed in raceways (including wire and cable pulling) and when performed on new or major remodel building projects or jobs for which the conductors for the fire alarm system are installed in conduit; excluding installation of raceway systems, line voltage work, industrial work, life-safety systems (all buildings having floors located more than 75' above the lowest floor level having building access); excluding energy management systems.

FOOTNOTE: Fire alarm work when installed in raceways (including wire and cable pulling), on projects which involve new or major remodel building construction, for which the conductors for the fire alarm system are installed in the conduit, shall be performed by the inside electrician.

ELEC0595-001 06/01/2020

ALAMEDA COUNTY

	Rates	Fringes
CABLE SPLICER.....	\$ 69.00	3%+38.52
ELECTRICIAN.....	\$ 60.00	3%+38.52