



INVITATION FOR BID
COMMERCIAL BOILER PREVENTATIVE
MAINTENANCE AND REPAIR SERVICES
IFB NO. B23005

Housing Authority of the City of Danbury
Danbury, Connecticut 06811

Issue Date: October 17th, 2023

Bid Due/Public Opening Date: November 8th, at 10:30am (EST)

An Affirmative Action/Equal Opportunity Employer
Minority/Women Business Enterprise are encouraged to apply





INVITATION FOR BID
Commercial Boiler Preventative Maintenance and Repair Services
IFB No. B23005

TABLE OF CONTENTS

I. INTRODUCTION.....	1
II. BACKGROUND.....	1
III. THE AUTHORITY’S MISSION	1
IV. GENERAL CONDITIONS	2
V. SCOPE OF WORK.....	2
VI. BID FORMAT	4
VII. BID SUBMISSION.....	5
VIII. BID EVALUATION.....	7
IX. CONTRACT AWARD.....	8



INVITATION FOR BID
Commercial Boiler Preventative Maintenance and Repair Services
IFB No. B23005

TABLE OF CONTENTS (continued)

ATTACHMENTS

ATTACHMENT A:	BID PRICE
ATTACHMENT B:	PROFILE OF FIRM
ATTACHMENT C:	HUD REQUIRED FORMS
ATTACHMENT D:	SECTION 3 COMPLIANCE
ATTACHMENT E:	SAMPLE CONTRACT
ATTACHMENT F:	BOILER MANUALS



INVITATION FOR BID
Commercial Boiler Preventative Maintenance and Repair Services
IFB No. B23005

F. INTRODUCTION

The Housing Authority of The City of Danbury (HACD) hereby issues this Invitation for Bid (IFB) for a qualified licensed firm to provide reliable and economical preventative maintenance and repair services on HACD commercial boilers. As herein described, HACD invites bids to satisfy the requirements set forth in this IFB.

II. BACKGROUND

Housing Authority of the City of Danbury (HACD)

The Housing Authority of The City of Danbury, located at 2 Mill Ridge Road, Danbury CT, 06811 was established in 1948 under the Connecticut General Statutes to provide decent, safe and sanitary housing to low-income and moderate income families.

The Authority is governed by a five (5) member Board of Commissioners appointed by the Mayor of the City of Danbury, Connecticut. The Authority's day-to-day operations are directed by the Authority's Executive Director.

The Authority is primarily funded through the United States Department of Housing and Urban Development. The Authority administers its programs from an operational budget of approximately 2 million per year and a total budget of approximately 12 million per year.

The Authority manages seven communities totaling approximately 900 apartment units. Of the seven communities, four are located in the downtown area, five of the communities are family developments and four are senior/disabled developments. In addition to administering the "Public Housing" program, the Authority administers approximately 1100 Section 8 vouchers under its "Housing Choice Voucher" program.

III. THE AUTHORITY'S MISSION

HACD's mission, in support of the City of Danbury, is to provide safe, affordable, and decent housing within the City of Danbury.



INVITATION FOR BID
Commercial Boiler Preventative Maintenance and Repair Services
IFB No. B23005

IV. GENERAL CONDITIONS

A. HACD'S RESERVATION OF RIGHTS

1. HACD reserves the right to reject any or all Bids, to waive any informality in the IFB process, or to terminate the IFB process at any time, if deemed by the HACD to be in its best interests.
2. HACD reserves the right not to award a contract pursuant to this IFB.
3. HACD reserves the right to terminate a contract awarded pursuant to this IFB, at any time for its convenience upon 10 days written notice to the successful Bidder(s).
4. HACD reserves the right to determine the days, hours and locations that the successful Bidder(s) shall provide the services called for in this IFB.
5. HACD reserves the right to retain all Bids submitted and not permit withdrawal for a period of 60 days subsequent to the deadline for receiving Bids without the written consent of the HACD Contracting Officer.
6. HACD reserves the right to negotiate the fees proposed by the Bidder entity.
7. HACD reserves the right to reject and not consider any Bid that does not meet the requirements of this IFB, including but not necessarily limited to incomplete Bids and/or Bids offering alternate or non-requested services.
8. HACD shall have no obligation to compensate any Bidder for any costs incurred in responding to this IFB.

V. SCOPE OF WORK

A. SCOPE OF SERVICES

Contractor shall provide boiler preventive maintenance and repair services for Camus, Burnham and Lochinvar Commercial Boilers.

1. Annual Preventative Maintenance

A schedule of units to be serviced will be provided by HACD.

After each unit is serviced a report of recommended improvements or necessary repairs to maintain the system in proper operating condition must be provided.

This report must contain an itemized estimate of parts, material, and labor costs. NO repairs or improvements will be undertaken without specific authorization from HACD.



INVITATION FOR BID
Commercial Boiler Preventative Maintenance and Repair Services
IFB No. B23005

Inspection services will include but are not limited to;
(See manuals for the full scope of recommended preventative maintenance attached hereto as **Attachment F**).

- Clean condensate trap
- Check all piping for leaks
- Check air openings
- Flue vent system and air piping
- Check water system • Check expansion tank
- Check boiler relief valve • Inspect ignition electrode
- Check ignition ground wiring
- Check all boiler wiring
- Check control settings
- Perform start-up and checks
- Check burner flame
- Check flame signal
- Check flue gas temperature
- General maintenance
- Cleaning boiler heat exchanger
- Oiled bearing circulators
- Test ignition transformer
- Replace worn ignition leads
- Inspect all parts for wear, corrosion; replace as required.
- Inspect thermostatic control systems for proper operation.
- Perform routine annual service on electric and gas unit heaters, in accordance with the manufacturer's operation and service manuals.
- Replace filters, gaskets, fasteners and gauge glass where required.
- Clean oil pump strainer; test for proper pump pressure and vacuum.
- Lubricate burner motors per manufacturer's recommendation.
- Check for proper gas pressure where applicable.
- Inspect and test all safety devices for proper operation. The boiler exterior and boiler room floors are to be left clean and to the satisfaction of the Facility Manager.



INVITATION FOR BID
Commercial Boiler Preventative Maintenance and Repair Services
IFB No. B23005

2. Regular On-Call Service

1. Emergency Calls made by HACD staff only, must be responded to within **one hour** of initial call.
2. Non-emergency requests should be scheduled within 72 hours of initial call.
3. Maximum allowable mark-up on parts is 12%. HACD reserves the right to request receipts of parts purchased for verification purposes.
4. Call backs within 24 hours of the initial service will not incur any additional labor charges.

VI. BID FORMAT

A written Bid shall be submitted in accordance with the following:

A. BID SUBMITTAL

Tab 1, Bid Price: The form Billing Rates is attached hereto as **Attachment A**, shall be fully completed, executed, and submitted under tab 1 as a part of the Bid submittal.

Tab 2, Profile of Firm Form: The Profile of Firm Form is attached hereto as **Attachment B**, shall be fully completed, executed, and submitted as a part of the Bid submittal.

Tab 3, HUD Required Forms: These forms attached hereto as **Attachment C**, shall be fully read, completed, executed/initialed, and submitted as a part of the Bid submittal.

Form HUD-5369-B, *Instructions to Offerors Non-Construction*
Form HUD-5370-C, *General Conditions for Non-Construction Contracts*

Tab 4, Section 3 Compliance Form: This form is attached hereto as **Attachment D**, shall be fully completed, executed, and submitted as a part of the Bid submittal.



INVITATION FOR BID
Commercial Boiler Preventative Maintenance and Repair Services
IFB No. B23005

Tab 5, Services:

The Bidder shall set forth its services submitted under tab 5 as a part of the Bid submittal which at a minimum shall detail documentation showing:

- Licenses
- Demonstrated Experience
- References (at least 3)
- Insurance Certificate

Tab 6, Equal Employment Opportunity:

The Supplier must submit a copy of its Equal Opportunity Employment Policy.

VII. BID SUBMISSION

All bids must be submitted and time-stamped received in the designated location no later than **November 8th, 2023 at 10:30 am (EST)**. A total of 1 UNBOUND original signature copy (**marked as "ORIGINAL"**) and 1 exact copy of the Bid submittal (**marked as "COPY"**), shall be placed unfolded in a sealed package and addressed to:

Housing Authority of the City of Danbury
Attention: Mrs. Lisa Gilchrist
Purchasing Agent
IFB No. B23005 – Commercial Boiler Services
2 Mill Ridge Road
Danbury, CT 06811

The package exterior must clearly denote the above noted **IFB No. B23005** and must have the Contractor's name and return address. Bids received after the published deadline will not be accepted.



INVITATION FOR BID
Commercial Boiler Preventative Maintenance and Repair Services
IFB No. B23005

A. SUBMISSION CONDITIONS

Do not fold or make any additional marks, notations, or requirements in the documents to be submitted. Bidders are not allowed to change any requirements or forms contained herein, either by making or entering onto these documents or the documents submitted any revisions or additions; and if any such additional marks, notations or requirements are entered on any of the documents that are submitted to HACD by the Supplier, such may invalidate that Bid. If, after accepting such a Bid, HACD decides that any such entry has not changed the intent of the Bid that HACD intended to receive, HACD may accept the Bid and the Bid shall be considered by HACD as if those additional marks, notations, or requirements were not entered on such.

B. SUBMISSION RESPONSIBILITY

It shall be the responsibility of each Supplier to be aware of and to abide by all dates, times, conditions, requirements, and specifications set forth within all applicable documents issued by HACD, including the IFB document and all attachments. By virtue of completing, signing and submitting the completed documents, the Supplier is stating his/her agreement to comply with all conditions and requirements set forth within those documents. Written notice from the Supplier not authorized in writing to exclude any HACD requirements contained within the documents may cause that Supplier to not be considered for award.

C. SUPPLIER RESPONSIBILITY

It is the responsibility of the Supplier to address all communication and correspondence pertaining to this IFB process to the Director of Procurement only. Bidders must not make inquiry or communicate with any other HACD staff member or official (including members of the Board of Commissioners) pertaining to this IFB. Failure to abide by this requirement may be cause for HACD to not consider a submitted Bid.

1. Questions:

DEADLINE FOR WRITTEN QUESTIONS

Bidders may submit questions in writing to the Housing Authority, 2 Mill Ridge Road, Danbury Connecticut 06811, Attn: Mrs. Lisa Gilchrist or e-mail: lgilchrist@hacdct.org. Such written questions must be received by November 1st, 2023 by 2:00pm (EST).



INVITATION FOR BID
Commercial Boiler Preventative Maintenance and Repair Services
IFB No. B23005

In order to maintain a fair and impartial competitive process, HACD can answer questions only in response to written questions received within the specified time frame. HACD must avoid private communication with the prospective Contractors during the solicitation period. Written questions will be the only opportunity for Bidders to ask questions as to form and content.

VIII. BID EVALUATION:

A. PUBLIC OPENING

All bids received by the submission deadline will be opened and publicly read aloud on November 8th, 2023 at 10:30am (EST); location: 2 Mill Ridge Rd, Danbury, CT 06811. At the bid opening HACD will only disclose the following information: (1) The company name of each bidder; (2) the total amount bid; and (3) the identity of the apparent lowest bidder. A copy of the bid tabulation or recap recorded will be made available to each member of the public attending such an opening and to anyone who requests such afterwards. The bids will not be made available for inspection by anyone at this time; HACD will, at a later time, review all bids in detail and will, in a timely manner, notify all bidders of any bidder that may be ruled to be non-responsive or not-responsible. HACD reserves the right to “waive informalities and minor irregularities” in the offers received). Bids will be available for inspection by the public after the award has been completed.

B. TIES

In the case of bids, the award shall be decided as detailed within Section 6.12.C of HUD Procurement Handbook 7460.8 REV 2, by “drawing lots or other random means of selection.”

C. RESPONSIVE EVALUATION

After the public opening the “hard copy” bid submittals received will be evaluated in private for responsiveness (i.e. meets the minimum of the requirements). Firms not meeting the minimum that are deemed to be non-responsive will be notified of such in writing by HACD in a timely manner.

D. RESPONSIBLE EVALUATION

HACD will evaluate the apparent lowest responsive bidder to ensure that he/she is responsible (i.e. a firm that is qualified, responsible and able to provide to HACD the



INVITATION FOR BID
Commercial Boiler Preventative Maintenance and Repair Services
IFB No. B23005

required services). If HACD ascertains that such firm has the required ability, capability, experience, knowledge, licensing, insurance and resources to provide the required services, HACD may proceed with award. If HACD determines that such firm is deemed to be not responsible, such firm will be notified of such in writing by HACD in a timely manner. In such case Evaluations with the next lowest bidder.

E. RESTRICTIONS

Any and all persons having ownership interest in a bidder entity or familial (including in-laws) and/or employment relationships (past or current) with principals and/or employees of a bidder entity will be excluded from participation in the evaluation of the bid.

IX. CONTRACT AWARD

A. LOWEST RESPONSIVE AND RESPONSIBLE BIDDER

Award of an IFB is made to the responsive and responsible bidder that submits the lowest cost.

B. PROCEDURE

By completing, executing, and submitting a bid, the Supplier agrees to abide by all terms and conditions pertaining to this IFB. HACD has no responsibility to conduct any negotiations pertaining to published requirements after the submittal deadline.

C. CONDITIONS

1. Contract Form

A contract will be executed on an HACD form only. A sample contract is Attached hereto as **Attachment E**.

D. CONTRACT TERM

The term of the contract awarded pursuant to the IFB shall be for a term of 1 year with the option to extend for four (4) additional one (1) year terms. Negotiations for a new fixed rate for each contract extension are permissible.

E. CERTIFICATE OF INSURANCE

The successful Supplier shall be required to procure and maintain during the term of the contract, adequate Public Liability and Property Damage Insurance, at limits acceptable



INVITATION FOR BID
Commercial Boiler Preventative Maintenance and Repair Services
IFB No. B23005

to HACD, insuring HACD, and shall agree to indemnify, defend, and hold harmless HACD from all claims and damages for personal injury, including accidental death, as well as from claims for property damages, which may arise from this contract, caused by Supplier, or by anyone directly or indirectly employed by Supplier; and shall provide and furnish HACD with Certificates of Insurance showing such coverage. HACD shall be named as an additional insured on all said insurance policies. Insurance will be in the amount of \$3,000,000 aggregate per occurrence and shall be primary and non-contributory.

F. CONTRACT SERVICE STANDARDS

All work performed pursuant to this IFB must conform and comply with all applicable local, state, and federal codes, statutes, laws, and regulations.

ATTACHMENT A

BID PRICING

ATTACHMENT B

PROFILE OF FIRM

INVITATION FOR BID (IFB) NO. B23005 , Commercial Boiler Services

**PROFILE OF FIRM
(Attachment B)**

This Form must be fully completed

Name of Firm: _____ Telephone: _____ Fax: _____

Street Address, City, State, Zip: _____

Identify Principals/Partners in Firm:

NAME	TITLE	% OF OWNERSHIP

Identify individual(s) that will act as project manager and other supervisory personnel on the project:

NAME	TITLE

Diversity Statement: You must circle all of the following that apply to the ownership of this firm and enter where provided the correct percentage (%) of ownership of each:

- Caucasian American (Male) _____ %
- Public-Held Corporation _____ %
- Government Agency _____ %
- Non-Profit Organization _____ %

Resident- (RBE), Minority- (MBE), or Woman-Owned (WBE) Business Enterprise (Qualifies by virtue of 51% or more ownership and active management by one or more of the following:

- Resident- Owned _____ %
- African American _____ %
- **Native American _____ %
- Hispanic American _____ %
- Asian/Pacific American _____ %
- Hasidic Jew _____ %
- Asian/Indian America _____ %
- Woman-Owned (MBE) _____ %
- Woman-Owned (Caucasian _____ %
- Disabled Veteran _____ %
- Other (Specify): _____

INVITATION FOR BID (IFB) NO. B23005 , Commercial Boiler Services

Profile of Firm
(Attachment B)

WMBE Certification Number: _____

Agency: _____

Federal Tax ID No.: _____

Business License No.: _____

State of _____ License Type and No.: _____

Worker's Compensation Insurance Carrier: _____

Policy No.: _____ Expiration Date: _____

General Liability Insurance Carrier: _____

Policy No. _____ Expiration Date: _____

Professional Liability Insurance Carrier: _____

Policy No. _____ Expiration Date: _____

Debarred Statement: Has this firm, or any principal(s) ever been debarred from providing any services by the Federal Government, any state government, the State of _____, or any local government agency within or without the State of _____? Yes No

If "Yes," please attach a full detailed explanation, including dates, circumstances and current status.

Disclosure Statement: Does this firm or any principals thereof have any current, past personal or professional relationship with any Commissioner or Officer of HACD? Yes No

If "Yes," please attach a full detailed explanation, including dates, circumstances and current status.

Non-Collusive Affidavit: The undersigned party submitting this proposal hereby certifies that such proposal is genuine and not collusive and that said proposer entity has not colluded, conspired, connived or agreed, directly or indirectly, with any proposer or person, to put in a sham proposal or to refrain from proposing, and has not in any manner, directly or indirectly sought by agreement or collusion, or communication or conference, with any person, to fix the proposal price of affiant or of any other proposer, to fix overhead, profit or cost element of said proposal price, or that of any other proposer or to secure any advantage against HACD or any person interested in the proposed contract; and that all statements in said proposal are true.

INVITATION FOR BID (IFB) NO. B23005 , Commercial Boiler Services

**Profile of Firm
(Attachment B)**

Verification Statement: The undersigned proposer hereby states that by completing and submitting this form he/she is verifying that all information provided herein is, to the best of his/her knowledge, true and accurate, and agrees that if HACD discovers that any information entered herein is false, that shall entitle HACD to not consider nor make award or to cancel any award with the undersigned party.

Signature

Print

Title

Company

Date

ATTACHMENT C

HUD REQUIRED FORMS

Instructions to Offerors Non-Construction

U.S. Department of Housing
and Urban Development
Office of Public and Indian Housing



- 03291 -

1. Preparation of Offers

(a) Offerors are expected to examine the statement of work, the proposed contract terms and conditions, and all instructions. Failure to do so will be at the offeror's risk.

(b) Each offeror shall furnish the information required by the solicitation. The offeror shall sign the offer and print or type its name on the cover sheet and each continuation sheet on which it makes an entry. Erasures or other changes must be initialed by the person signing the offer. Offers signed by an agent shall be accompanied by evidence of that agent's authority, unless that evidence has been previously furnished to the HA.

(c) Offers for services other than those specified will not be considered.

2. Submission of Offers

(a) Offers and modifications thereof shall be submitted in sealed envelopes or packages (1) addressed to the office specified in the solicitation, and (2) showing the time specified for receipt, the solicitation number, and the name and address of the offeror.

(b) Telegraphic offers will not be considered unless authorized by the solicitation; however, offers may be modified by written or telegraphic notice.

(c) Facsimile offers, modifications or withdrawals will not be considered unless authorized by the solicitation.

3. Amendments to Solicitations

(a) If this solicitation is amended, then all terms and conditions which are not modified remain unchanged.

(b) Offerors shall acknowledge receipt of any amendments to this solicitation by

- (1) signing and returning the amendment;
- (2) identifying the amendment number and date in the space provided for this purpose on the form for submitting an offer,
- (3) letter or telegram, or
- (4) facsimile, if facsimile offers are authorized in the solicitation. The HA/HUD must receive the acknowledgment by the time specified for receipt of offers.

4. Explanation to Prospective Offerors

Any prospective offeror desiring an explanation or interpretation of the solicitation, statement of work, etc., must request it in writing soon enough to allow a reply to reach all prospective offerors before the submission of their offers. Oral explanations or instructions given before the award of the contract will not be binding. Any information given to a prospective offeror concerning a solicitation will be furnished promptly to all other prospective offerors as an amendment of the solicitation, if that information is necessary in submitting offers or if the lack of it would be prejudicial to any other prospective offerors.

5. Responsibility of Prospective Contractor

(a) The HA shall award a contract only to a responsible prospective contractor who is able to perform successfully under the terms and conditions of the proposed contract. To be determined responsible, a prospective contractor must -

- (1) Have adequate financial resources to perform the contract, or the ability to obtain them;

- (2) Have a satisfactory performance record;
- (3) Have a satisfactory record of integrity and business ethics;
- (4) Have a satisfactory record of compliance with public policy (e.g., Equal Employment Opportunity); and
- (5) Not have been suspended, debarred, or otherwise determined to be ineligible for award of contracts by the Department of Housing and Urban Development or any other agency of the U.S. Government. Current lists of ineligible contractors are available for inspection at the HA/HUD.

(b) Before an offer is considered for award, the offeror may be requested by the HA to submit a statement or other documentation regarding any of the foregoing requirements. Failure by the offeror to provide such additional information may render the offeror ineligible for award.

6. Late Submissions, Modifications, and Withdrawal of Offers

(a) Any offer received at the place designated in the solicitation after the exact time specified for receipt will not be considered unless it is received before award is made and it -

- (1) Was sent by registered or certified mail not later than the fifth calendar day before the date specified for receipt of offers (e.g., an offer submitted in response to a solicitation requiring receipt of offers by the 20th of the month must have been mailed by the 15th);
- (2) Was sent by mail, or if authorized by the solicitation, was sent by telegram or via facsimile, and it is determined by the HA/ HUD that the late receipt was due solely to mishandling by the HA/ HUD after receipt at the HA;
- (3) Was sent by U.S. Postal Service Express Mail Next Day Service - Post Office to Addressee, not later than 5:00 p.m. at the place of mailing two working days prior to the date specified for receipt of proposals. The term "working days" excludes weekends and U.S. Federal holidays; or
- (4) Is the only offer received.

(b) Any modification of an offer, except a modification resulting from the HA's request for "best and final" offer (if this solicitation is a request for proposals), is subject to the same conditions as in subparagraphs (a)(1), (2), and (3) of this provision.

(c) A modification resulting from the HA's request for "best and final" offer received after the time and date specified in the request will not be considered unless received before award and the late receipt is due solely to mishandling by the HA after receipt at the HA.

(d) The only acceptable evidence to establish the date of mailing of a late offer, modification, or withdrawal sent either by registered or certified mail is the U.S. or Canadian Postal Service postmark both on the envelope or wrapper and on the original receipt from the U.S. or Canadian Postal Service. Both postmarks must show a legible date or the offer, modification, or withdrawal shall be processed as if mailed late. "Postmark" means a printed, stamped, or otherwise placed impression (exclusive of a postage meter machine impression) that is readily identifiable without further action as having been supplied and affixed by employees of the U.S. or Canadian Postal Service on the date of mailing. Therefore, offerors should request the postal clerk to place a hand cancellation bull's-eye postmark on both the receipt and the envelope or wrapper.

(e) The only acceptable evidence to establish the time of receipt at the HA is the time/date stamp of HA on the offer wrapper or other documentary evidence of receipt maintained by the HA.

(f) The only acceptable evidence to establish the date of mailing of a late offer, modification, or withdrawal sent by Express Mail Next Day Service-Post Office to Addressee is the date entered by the post office receiving clerk on the "Express Mail Next Day Service-Post Office to Addressee" label and the postmark on both the envelope or wrapper and on the original receipt from the U.S. Postal Service. "Postmark" has the same meaning as defined in paragraph (c) of this provision, excluding postmarks of the Canadian Postal Service. Therefore, offerors should request the postal clerk to place a legible hand cancellation bull's eye postmark on both the receipt and the envelope or wrapper.

(g) Notwithstanding paragraph (a) of this provision, a late modification of an otherwise successful offer that makes its terms more favorable to the HA will be considered at any time it is received and may be accepted.

(h) If this solicitation is a request for proposals, proposals may be withdrawn by written notice, or if authorized by this solicitation, by telegram (including mailgram) or facsimile machine transmission received at any time before award. Proposals may be withdrawn in person by a offeror or its authorized representative if the identity of the person requesting withdrawal is established and the person signs a receipt for the offer before award. If this solicitation is an invitation for bids, bids may be withdrawn at any time prior to bid opening.

7. Contract Award

(a) The HA will award a contract resulting from this solicitation to the responsible offeror whose offer conforming to the solicitation will be most advantageous to the HA, cost or price and other factors, specified elsewhere in this solicitation, considered.

(b) The HA may

- (1) reject any or all offers if such action is in the HA's interest,
- (2) accept other than the lowest offer,
- (3) waive informalities and minor irregularities in offers received, and (4) award more than one contract for all or part of the requirements stated.

(c) If this solicitation is a request for proposals, the HA may award a contract on the basis of initial offers received, without discussions. Therefore, each initial offer should contain the offeror's best terms from a cost or price and technical standpoint.

(d) A written award or acceptance of offer mailed or otherwise furnished to the successful offeror within the time for acceptance specified in the offer shall result in a binding contract without further action by either party. If this solicitation is a request for proposals, before the offer's specified expiration time, the HA may accept an offer, whether or not there are negotiations after its receipt, unless a written notice of withdrawal is received before award. Negotiations conducted after receipt of an offer do not constitute a rejection or counteroffer by the HA.

(e) Neither financial data submitted with an offer, nor representations concerning facilities or financing, will form a part of the resulting contract.

8. Service of Protest

Any protest against the award of a contract pursuant to this solicitation shall be served on the HA by obtaining written and dated acknowledgment of receipt from the HA at the address shown on the cover of this solicitation. The determination of the HA with regard to such protest or to proceed to award notwithstanding such protest shall be final unless appealed by the protestor.

9. Offer Submission

Offers shall be submitted as follows and shall be enclosed in a sealed envelope and addressed to the office specified in the solicitation. The proposal shall show **the hour and date specified in the solicitation for receipt, the solicitation number, and the name and address of the offeror, on the face of the envelope.**

It is very important that the offer be properly identified on the face of the envelope as set forth above in order to insure that the date and time of receipt is stamped on the face of the offer envelope. Receiving procedures are: date and time stamp those envelopes identified as proposals and deliver them immediately to the appropriate contracting official, and only date stamp those envelopes which do not contain identification of the contents and deliver them to the appropriate procuring activity only through the routine mail delivery procedure.

[Describe bid or proposal preparation instructions here:]

General Conditions for Non-Construction Contracts

Section II – (With Maintenance Work)

U.S. Department of Housing and Urban Development

Office of Public and Indian Housing

Office of Labor Relations

OMB Approval No. 2577-0157 (exp. 11/30/2023)

Public Reporting Burden for this collection of information is estimated to average one hour per response, including the time for reviewing instructions, searching existing data sources, gathering and maintaining the data needed, and completing and reviewing the collection of information. HUD may not conduct or sponsor, and an applicant is not required to respond to a collection of information unless it displays a currently valid OMB control number.

Applicability. This form HUD-5370C has 2 Sections. These Sections must be inserted into non-construction contracts as described below:

- 1) Non-construction contracts (*without* maintenance) greater than \$150,000 - use Section I;
- 2) Maintenance contracts (including nonroutine maintenance as defined at 24 CFR 905.200) greater than \$2,000 but not more than \$150,000 - use Section II; and
- 3) Maintenance contracts (including nonroutine maintenance), greater than \$150,000 – use Sections I and II.

Section II – Labor Standard Provisions for all Maintenance Contracts greater than \$2,000

1. Minimum Wages

- (a) All maintenance laborers and mechanics employed under this Contract in the operation of the project(s) shall be paid unconditionally and not less often than semi-monthly, and without subsequent deduction (except as otherwise provided by law or regulations), the full amount of wages due at time of payment computed at rates not less than those contained in the wage determination of the Secretary of Housing and Urban Development which is attached hereto and made a part hereof. Such laborers and mechanics shall be paid the appropriate wage rate on the wage determination for the classification of work actually performed, without regard to skill. Laborers or mechanics performing work in more than one classification may be compensated at the rate specified for each classification for the time actually worked therein; provided, that the employer's payroll records accurately set forth the time spent in each classification in which work is performed. The wage determination, including any additional classifications and wage rates approved by HUD under subparagraph 1(b), shall be posted at all times by the Contractor and its subcontractors at the site of the work in a prominent and accessible place where it can be easily seen by the workers.
- (b) (i) Any class of laborers or mechanics which is not listed in the wage determination and which is to be employed under the Contract shall be classified in conformance with the wage determination. HUD shall approve an additional classification and wage rate only when the following criteria have been met:
 - (1) The work to be performed by the classification required is not performed by a classification in the wage determination;
 - (2) The classification is utilized in the area by the industry; and
 - (3) The proposed wage rate bears a reasonable relationship to the wage rates contained in the wage determination.(ii) The wage rate determined pursuant to this paragraph shall be paid to all workers performing work

in the classification under this Contract from the first day on which work is performed in the classification.

2. Withholding of funds

The Contracting Officer, upon his/her own action or upon request of HUD, shall withhold or cause to be withheld from the Contractor under this Contract or any other contract subject to HUD-determined wage rates, with the same prime Contractor, so much of the accrued payments or advances as may be considered necessary to pay laborers and mechanics employed by the Contractor or any subcontractor the full amount of wages required by this clause. In the event of failure to pay any laborer or mechanic employed under this Contract all or part of the wages required under this Contract, the Contracting Officer or HUD may, after written notice to the Contractor, take such action as may be necessary to cause the suspension of any further payment or advance until such violations have ceased. The Public Housing Agency or HUD may, after written notice to the Contractor, disburse such amounts withheld for and on account of the Contractor or subcontractor to the respective employees to whom they are due.

3. Records

- (a) The Contractor and each subcontractor shall make and maintain for three (3) years from the completion of the work records containing the following for each laborer and mechanic:
 - (i) Name, address and Social Security Number;
 - (ii) Correct work classification or classifications;
 - (iii) Hourly rate or rates of monetary wages paid;
 - (iv) Rate or rates of any fringe benefits provided;
 - (v) Number of daily and weekly hours worked;
 - (vi) Gross wages earned;
 - (vii) Any deductions made; and
 - (viii) Actual wages paid.
- (b) The Contractor and each subcontractor shall make the records required under paragraph 3(a) available for inspection, copying, or transcription by authorized representatives of HUD or the HA and shall permit such representatives to interview employees during working hours on the job. If the Contractor or any subcontractor fails to make the required records available, HUD or its designee may, after written notice to the Contractor, take such action as may be necessary to cause the suspension of any further payment, advance or guarantee of funds.

4. Apprentices and Trainees

- (a) Apprentices and trainees will be permitted to work at less than the predetermined rate for the work they perform when they are employed pursuant to and individually registered in:
 - (i) A bona fide apprenticeship program registered with the U.S. Department of Labor, Employment and Training Administration (ETA), Office of

Apprenticeship Training, Employer and Labor Services (OATELS), or with a state apprenticeship agency recognized by OATELS, or if a person is employed in his/her first 90 days of probationary employment as an apprentice in such an apprenticeship program, who is not individually registered in the program, but who has been certified by OATELS or a state apprenticeship agency (where appropriate) to be eligible for probationary employment as an apprentice; A

- (ii) A trainee program which has received prior approval, evidenced by formal certification by the U.S. Department of Labor, ETA; or
- (iii) A training/trainee program that has received prior approval by HUD.

- (b) Each apprentice or trainee must be paid at not less than the rate specified in the registered or approved program for the apprentice's/trainee's level of progress, expressed as a percentage of the journeyman hourly rate specified in the applicable wage determination. Apprentices and trainees shall be paid fringe benefits in accordance with the provisions of the registered or approved program. If the program does not specify fringe benefits, apprentices/trainees must be paid the full amount of fringe benefits listed on the wage determination for the applicable classification.
- (c) The allowable ratio of apprentices or trainees to journeyman on the job site in any craft classification shall not be greater than the ratio permitted to the employer as to the entire work force under the approved program.
- (d) Any worker employed at an apprentice or trainee wage rate who is not registered in an approved program, and any apprentice or trainee performing work on the job site in excess of the ratio permitted under the approved program, shall be paid not less than the applicable wage rate on the wage determination for the classification of work actually performed.
- (e) In the event OATELS, a state apprenticeship agency recognized by OATELS or ETA, or HUD, withdraws approval of an apprenticeship or trainee program, the employer will no longer be permitted to utilize apprentices/trainees at less than the applicable predetermined rate for the work performed until an acceptable program is approved.

5. Disputes concerning labor standards

- (a) Disputes arising out of the labor standards provisions contained in Section II of this form HUD-5370-C, other than those in Paragraph 6, shall be subject to the following procedures. Disputes within the meaning of this paragraph include disputes between the Contractor (or any of its subcontractors) and the HA, or HUD, or the employees or their representatives, concerning payment of prevailing wage rates or proper classification. The procedures in this section may be initiated upon HUD's own motion, upon referral of the HA, or upon request of the Contractor or subcontractor(s).
 - (i) A Contractor and/or subcontractor or other interested party desiring reconsideration of findings of violation by the HA or HUD relating to the payment of straight-time prevailing wages or classification of work shall request such reconsideration by letter postmarked within 30 calendar days of the date of notice of findings issued by the HA or HUD. The request shall set

forth those findings that are in dispute and the reasons, including any affirmative defenses, with respect to the violations. The request shall be directed to the appropriate HA or HUD official in accordance with instructions contained in the notice of findings or, if the notice does not specify to whom a request should be made, to the Regional Labor Relations Officer (HUD). The HA or HUD official shall, within 60 days (unless otherwise indicated in the notice of findings) after receipt of a timely request for reconsideration, issue a written decision on the findings of violation. The written decision on reconsideration shall contain instructions that any appeal of the decision shall be addressed to the Regional Labor Relations Officer by letter postmarked within 30 calendar days after the date of the decision. In the event that the Regional Labor Relations Officer was the deciding official on reconsideration, the appeal shall be directed to the Director, Office of Labor Relations (HUD). Any appeal must set forth the aspects of the decision that are in dispute and the reasons, including any affirmative defenses, with respect to the violations. The Regional Labor Relations Officer shall, within 60 days (unless otherwise indicated in the decision on reconsideration) after receipt of a timely appeal, issue a written decision on the findings. A decision of the Regional Labor Relations Officer may be appealed to the Director, Office of Labor Relations, by letter postmarked within 30 days of the Regional Labor Relations Officer's decision. Any appeal to the Director must set forth the aspects of the prior decision(s) that are in dispute and the reasons. The decision of the Director, Office of Labor Relations, shall be final.

- (b) Disputes arising out of the labor standards provisions of paragraph 6 shall not be subject to paragraph 5(a) of this form HUD-5370C. Such disputes shall be resolved in accordance with the procedures of the U.S. Department of Labor set forth in 29 CFR Parts 5, 6 and 7. Disputes within the meaning of this paragraph 5(b) include disputes between the Contractor (or any of its subcontractors) and the HA, HUD, the U.S. Department of Labor, or the employees or their representatives.

6. Contract Work Hours and Safety Standards Act

The provisions of this paragraph 6 are applicable only where the amount of the prime contract exceeds \$100,000. As used in this paragraph, the terms "laborers" and "mechanics" includes watchmen and guards.

- (a) **Overtime requirements.** No Contractor or subcontractor contracting for any part of the Contract work which may require or involve the employment of laborers or mechanics shall require or permit any such laborer or mechanic in any workweek in which he or she is employed on such work to work in excess of 40 hours in such workweek unless such laborer or mechanic receives compensation at a rate not less than one and one-half times the basic rate of pay for all hours worked in excess of 40 hours in such workweek.
- (b) **Violation; liability for unpaid wages; liquidated damages.** In the event of any violation of the provisions set forth in paragraph 6(a), the Contractor and any

subcontractor responsible therefor shall be liable for the unpaid wages. In addition, such Contractor and subcontractor shall be liable to the United States (in the case of work done under contract for the District of Columbia or a territory, to the District or to such territory), for liquidated damages. Such liquidated damages shall be computed with respect to each individual laborer or mechanic, including watchmen and guards, employed in violation of the provisions set forth in paragraph (a) of this clause, in the sum of \$10 for each calendar day on which such individual was required or permitted to work in excess of the standard workweek of 40 hours without payment of the overtime wages required by provisions set forth in paragraph (a) of this clause.

- (c) **Withholding for unpaid wages and liquidated damages.** HUD or its designee shall upon its own action or upon written request of an authorized representative of the U.S. Department of Labor withhold or cause to be withheld, from any moneys payable on account of work performed by the Contractor or subcontractor under any such Contract or any federal contract with the same prime Contractor, or any other federally-assisted contract subject to the Contract Work Hours and Safety Standards Act, which is held by the same prime Contractor such sums as may be determined to be necessary to satisfy any liabilities of such Contractor or subcontractor for unpaid wages and liquidated damages as provided in the provisions set forth in paragraph (b) of this clause.

7. Subcontracts

The Contractor or subcontractor shall insert in any subcontracts all the provisions contained in this Section II and also a clause requiring the subcontractors to include these provisions in any lower tier subcontracts. The prime Contractor shall be responsible for the compliance by any subcontractor or lower tier subcontractor with all the provisions contained in these clauses.

8. Non-Federal Prevailing Wage Rates

Any prevailing wage rate (including basic hourly rate and any fringe benefits), determined under state law to be prevailing, with respect to any employee in any trade or position employed under the Contract, is inapplicable to the contract and shall not be enforced against the Contractor or any subcontractor, with respect to employees engaged under the contract whenever such non-Federal prevailing wage rate, exclusive of any fringe benefits, exceeds the applicable wage rate determined by the Secretary of HUD to be prevailing in the locality with respect to such trade or position.

ATTACHMENT D

SECTION 3 COMPLIANCE

Housing Authority of the City of Danbury

SECTION 3 NEW RULE 24 CFR Part 75

On November 30, 2020, HUD put into effect a New and Final Section 3 Rule for all recipients. This rule is drastically different from the old rule and therefore, we want everyone to know these requirements and plan accordingly.

Every contractor must ensure this package is included in their sub-contracts. Every sub-contractor must include this package in their lower-tiered sub-contracts.

This new rule exempts all material and supply only agreements. The rule applies to all service related contracts/agreements despite the dollar amount or project duration, except CPA's, Attorneys, Engineers, and Architects.

Non-Danbury Housing Authority Public Housing or Section 8 residents can NOT certify to their income nor can any current YouthBuild participants under The State of Connecticut's Substitute House Bill No. 5386 Public Act No. 18-8 An Act Concerning Pay Equity. Do Not request or require any applicant on any Danbury Housing Authority contract to provide any of their current or prior salary/income or you will violate the state law.

You should not issue the Individual or Business Self-Certification form(s) until you have secured a qualified contractor or employee respectively. DO NOT hand the individual self-certification form to every employee as it may be a waste of time if they were not hired within the past five years and were low-income, public housing, or Section 8 at the time of hire.

Documents included in this package:

✱ New Requirements Summary	15
✱ Monthly Reporting Instructions	16
✱ Section 3 Business Self-Certification Forms	17
✱ Section 3 Individual Self-Certification Forms	18
✱ Hours Worked Reporting Form	19
✱ Acknowledgment and Affidavit Form	20

The Acknowledgement and Affidavit must be executed and returned by Every Contractor.

Housing Authority of the City of Danbury
Annual "Section 3 Benchmarks" Requirement Summary

- ✳ Twenty (20) percent or more of the total number of labor hours worked by all workers employed with public housing financial assistance in a HA's fiscal year are Section 3 workers; and
- ✳ Five (5) percent or more of the total number of labor hours worked by all workers employed with public housing financial assistance in a HA's fiscal year are Section 3 workers;
- ✳ There are No specific hiring or contracting goals under this new rule.
- ✳ There is No Section 3 Business Preference under the new rule and No points awarded for being a Section 3 Business.
- ✳ The rule does not require the hiring or contracting of any person or business that is not fully qualified to perform the work.

The two new categories of Section 3 are now referred to as:

- ✳ **Section 3 Worker** - Any low or very low-income persons residing in the housing authority MSA
- ✳ **Targeted Section 3 Worker** - Public Housing, Voucher Holder, YouthBuild participant

Contractors will provide these three (3) data sets to the Danbury Housing Authority's Section 3 Consultant within 40 days of the month after the hours have been worked by EVERY person that worked directly on the contract. (**Ex:** April data is required by June 10th) No back-office staff hours are counted:

- ✳ Total Hours Worked by all workers
- ✳ Total Hours Worked by Section 3 Workers (Individual Self-Certification Form Required)
- ✳ Total Hours worked by Targeted Section 3 Workers (Individual Self-Certification Form Required)

There are new definitions of how to be a Section 3 Business Concern:

- ✳ It is at least 51 percent owned by low- or very low-income persons; with businesses at least 6 months old
- ✳ Over 75 percent of the labor hours performed for the business are performed by low- or very low-income persons; or (Based on the prior 90 days of full business payrolls)
- ✳ It is a business at least 51 percent owned by current public housing residents or residents who currently live in Section 8-assisted housing, with businesses at least 6 months old

MONTHLY REPORTING INSTRUCTIONS

STEP ONE

Enter your company name and the name of the contract or task you are performing in the appropriate lines at the top of the form.

STEP TWO

Determine which workers qualify as Section 3 by having each complete a **Section 3 Individual Low-Income Person Self-Certification Form**. This form is submitted once per Section 3 employee or those that believe they meet the definition of a Section 3 employee.

The form is to be completed by the individual and stress to the employee that the form is Voluntary:

1. Complete contact info section
2. Check the box that describes your situation
3. Sign and date the form
4. Complete the employer information
5. Return to your employer

STEP THREE

After determining which workers are Section 3, determine their classification based on what they check in the box on the form as **Non-Targeted** or **Targeted**:

Non-Targeted are those Section 3 income-qualified workers who are low-income and reside in the MSA.

Targeted are those Section 3 income-qualified workers who are low-income and reside in public housing, Section 8 or YouthBuild

STEP FOUR

Enter the monthly dates of reporting on the first line, then proceed as follows:

1. Enter total hours worked by ALL contract or project level staff with exceptions as noted above*
2. Enter total hours worked by all Section 3 staff **Non-Targeted**
3. Enter total hours worked by all Section 3 staff **Targeted**

List **ONLY** the individual names of the workers who have self-certified as Section 3 (**Non-Targeted** and **Targeted**) along with their total hours for this months report only.

STEP FIVE

Submit the Section 3 Hours Worked Reporting Form on a monthly basis to the contact person noted on your reporting form above.

SECTION 3 BUSINESS

Voluntary Self-Certification Form

IN COMPLIANCE WITH SECTION 3 OF THE HUD ACT OF 1968 UPDATED 24 CFR PART 75 11/30/2020

The purpose of this form is to comply with Section 3 of the HUD Act of 1968 Business Certification requirements. To count as a Section 3 Business your company/firm must meet one of the listed categories below. Each category will require additional documentation to support the election. You must provide that supporting documentation with this form properly completed to be confirmed as a Section 3 business. If this form is submitted without the required supplemental data, your certification will not be processed.

CATEGORY	DOCUMENTATION REQUIRED	YOUR ELECTION
a business at least 51 percent owned by low- or very low-income persons;	Proof of ownership showing all owners and their percentages and a completed Section 3 Individual Self-Certification form for all low- and very low-income owners	← I N I T I A L ← H E R E ←
Over 75 percent of the labor hours performed for the business are performed by low- or very low-income persons; or	Provide the last 90 days full payrolls for the entire company, make a list of the names from the payrolls of the Section 3 workers, and provide a completed Section 3 Individual Self- Certification for all low- and very low-income workers you list	
It is a business at least 51 percent owned by current public housing residents or residents who currently live in Section 8-assisted housing.	Proof of ownership showing all owners and their percentages and a Section 3 Individual Self-Certification form for all public housing and/or Section 8 owners	

I hereby certify to the US Department of Housing and Urban Development (HUD) that all of the information on this form is true and correct. I attest under penalty of perjury that my business meets the elected definition and understand proof of this information may be requested. If found to be inaccurate, I understand that I may be disqualified as a certified Section 3 business.

Full Name: _____

Company Name: _____

Street Address: _____

City: _____ State: _____ Zip: _____

Signature: _____ Date: _____

SECTION 3 INDIVIDUAL LOW-INCOME PERSON

Voluntary Self-Certification Form

IN COMPLIANCE WITH SECTION 3 OF THE HUD ACT OF 1968 UPDATED 24 CFR PART 75 11/30/2020

The purpose of this form is to comply with Section 3 of the HUD Act of 1968 self-certification income requirements. To count as a Section 3 individual, any legal resident of the United States annual income must not exceed the HUD income limits for the year before they were hired, or, the individual's current year income annualized for the year they are being confirmed as low-income.

Print Name

Phone	Email
-------	-------

Address

City	State	Zip
------	-------	-----

To qualify as a Section 3 Person, you must meet one of the standards in the brackets below.

Check only one box below that describes your situation:

I am a Public Housing Resident, Section 8 assists me with my rent, or I am a current YouthBuild participant

I receive No HUD support, but I am low-income and live in the Danbury MSA

My employer will certify I work for a Section 3 Business

The Bridgeport, CT HUD Metro FMR Area contains the following areas:

FAIRFIELD COUNTY, CT TOWNS OF Bridgeport town, CT; Easton town, CT; Fairfield town, CT; Monroe town, CT; Shelton town, CT; Stratford town, CT; Trumbull town, CT; and Trumbull town, CT.

I hereby certify to the US Department of Housing and Urban Development (HUD) that all of the information on this form is true and correct. I attest under penalty of perjury that my total income is as shown above, and that proof of this information may be requested. If found to be inaccurate, I understand that I may be disqualified as an applicant and/or a certified Section 3 individual. Finally, I authorize including my name on a list of Section 3 Residents seeking employment and to include my contact information so that contractors may contact me directly for any employment opportunities.

Signature: _____

Date: _____

Hours Worked Reporting Form

IN COMPLIANCE WITH SECTION 3 OF THE HUD ACT OF 1968 UPDATED 24 CFR PART 75 11/30/2020

The purpose of this form is to comply with Section 3 of the HUD Act of 1968 tracking of hours worked by all person's employed on the Danbury Housing Authority contract including those meeting the Section 3 income requirements as low- or very low-income.

Section 3 Employees are now defined to as:

Section 3 Workers - Any low or very low-income persons residing within the Danbury Housing Authority MSA (Metro Area)

Targeted Section 3 Workers - I reside in public housing or Section 8 housing managed by Danbury Housing Authority or a current YouthBuild participants (If a program is active in the area)

If your company employs any person it believe is low income now or was when they were hired within the past five years, please have them complete the SECTION 3 INDIVIDUAL LOW-INCOME PERSON SELF-CERTIFICATION FORM" and return it with their first report of employment in the Hours Worked Reporting System.

All hours worked by everyone on the project must be reported monthly electronically. If you have questions please contact the projects Section 3 Consultant:

Motivation Compliance and Training, Inc.
Katie Swiney, Compliance Manager
admin@m-cat.co

In the software, you will report this information for your team as they apply.

- ✱ Total Hours Worked by non-Section 3 staff
- ✱ Total hours worked by all **Non-targeted** Section 3 employees
- ✱ Total hours worked by all **Targeted** Section 3 employee

The reporting system website is: To Be Provided Separately

Danbury Housing Authority

Section 3 New Rule Contractor Acknowledgement and Affidavit

(Return this form with your Contract)

Company Name: _____

Contract or Project Name: _____

Trade Work/Classification: _____

I hereby certify to the US Department of Housing and Urban Development (HUD) that I have read all of the information in this policy package and agree to follow the requirements for complying with the order of prioritization in 75.9 and 75.19 and reporting of all labor hours associated with my contract as required. I further understand that failure to comply with these requirements will cause my payments to be held and not processed or not released until I come into full compliance with this policy.

Monthly, I will be required to provide these data points for all contract staff working directly on the contract **not including any back-office staff**:

- Total Hours Worked by all employees (Section 3 and regular employees)
- Total Hours Worked by All **Non-Targeted Section 3 employees** (Low-Income persons residing within a one-mile radius of the project location)
- Total Hours Worked by All **Targeted Section 3 employees** (Current YouthBuild participants)

You are required to enter the names and hours worked by each Section 3 employee individually.

Signature: _____ Print: _____ Date: _____

ATTACHMENT E

Sample Contract



**IFB No. B21003, Plumbing Services
CONTRACT NO. C21003**

**CONTRACT BETWEEN
THE HOUSING AUTHORITY OF THE CITY OF DANBURY
AND
XXXXXXXXXX**

INTRODUCTION

This agreement by and between Housing Authority of the City of Danbury (hereinafter “HACD”), 2 Mill Ridge Road, Danbury, CT 06811 acting herein by Jeff M. Rieck its Executive Director and XXXXXX, a XXXX business authorized to do business in the State of Connecticut, with a business mailing address of XXXX (hereinafter “the Contractor”), acting herein by XXXXXX, its XXXXXX is made this XX day of XXX, 2021 (the “Contract”).

WHEREAS, HACD issued an Invitation for Bid for Plumbing Services pursuant to IFB No. B21003 (hereinafter “IFB”); and

WHEREAS, Contractor submitted a bid to provide services in response to the IFB (“Contractor’s Bid”); and

WHEREAS, HACD has determined that Contractor is the lowest responsive and responsible bidder to the IFB; and

WHEREAS, HACD and Contractor desire to set forth the terms and conditions pertaining to the services to be rendered by Contractor.

NOW THEREFORE, in consideration of the mutual promises herein set forth, the parties agree to the following:

1. Term

This Contract is for a term of one (1) year (“Initial Term”). HACD, at its sole discretion, may extend the Contract for four (4) additional one-year terms (“Extended Term”), for a total maximum term of five (5) years. HACD shall exercise its option to extend by notifying Contractor in writing fifteen (15) days prior to the end of the then current term.



**IFB No. B21003, Plumbing Services
CONTRACT NO. C21003**

2. Services

2.1 Scope of Services: Contractor shall perform all services and work described in the Scope of Services in the IFB and as set forth in Contractor's Bid which are incorporated into this Contract and as set forth in Contractor's Bid by reference (hereinafter referred to as the "Services" or "Work").

2.2 Provisions of any and all Work: The Contractor shall not perform any service without prior authorization by HACD.

3. Contract Sum for HACD

During the Initial Term, HACD shall pay Contractor for the Services described herein a total amount not to exceed XXXXXX (\$XXX).

In the event Contractor exceeds any of the not to exceed amounts set forth herein it does so at its own risk.

3.1 Time Performance: The Contractor shall complete the Services in a timely manner and in as mutually agreed to.

4. Method of Payment

Payment for the Services shall only be made pursuant to the following billing procedure:

(i) The Contractor shall submit an invoice for Services not more frequently than on a monthly basis via email to AccountsPayable@hacdct.org or by mail to:

**Housing Authority of the City of Danbury
Attn: Accounts Payable
2 Mill Ridge Road
Danbury, CT 06811**

(ii) The invoice for Services shall include the following information:

- Unique invoice number;
- Contractor's name, address and telephone number;
- Date of invoice;
- Billing Period covered by invoice;



**IFB No. B21003, Plumbing Services
CONTRACT NO. C21003**

- Applicable Contract Number;
- Description of Services rendered, including date of Service, total hours billed for Service, the location or site where Service was performed, the rate charged for the Service;
- Any other supporting documentation for Services reasonably requested by HACD;
- Total dollar amount being invoiced.

(iii) HACD shall pay each properly completed invoice for Services on a Net 30-day basis from date of submission of a properly completed invoice for Services, subject to section 10.0 herein. Incomplete invoices or invoices that do not comply with this section shall not be paid unless or until the Contractor complies with this section.

5.0 Commencement Date

This Contract shall commence on XXXXXX and shall terminate on XXXXXX unless extended by HACD as herein provided.

6.0 Contractor's Obligations

In the performance of the Services, the Contractor agrees as follows:

- 6.1 Performance of Work:** Contractor agrees to fully perform the Services in a good, complete, thorough and workmanlike manner. All work performed and all materials furnished in connection with the Service shall be in accordance with the standard practices of the trade. In the event the Contractor, in the opinion of the Owner, fails to supply or materially delays (a) properly skilled workmen, (b) material of proper quality, (c) the performance and discharge of its work with promptness, diligence or in a workmanlike manner or, (d) fails to abide by appropriate codes, then, in each instance, the Owner shall have the right at Owner's sole discretion, to terminate the Contract.
- 6.2 Supervision and Oversight:** The Contractor shall be solely responsible for providing supervision and oversight to all of the Contractor's personnel that are assigned to HACD properties pursuant to this Contract.
- 6.3 Qualified Personnel:** The Contractor warrants and represents that it shall assign only qualified personnel ("Qualified Personnel") to perform the Services. For the purposes of this Contract, the term "Qualified Personnel" shall mean those personnel that have been investigated, tested and trained to perform the Services in the manner required by this Contract and, as proposed by the Contractor within its response to IFB No. B21003.



**IFB No. B21003, Plumbing Services
CONTRACT NO. C21003**

6.4 Insurance Requirements:

6.4.1 In addition to the indemnity requirements detailed in Section 12.16 herein, the Contractor shall maintain the following insurance coverages during the term(s) of this Contract:

6.4.1.1 Policy of General Liability Insurance, \$1,000,000 per occurrence, \$1,000,000 aggregate together with damage to premises and fire damage of \$50,000 and medical expenses for any one person of \$5,000 with a deductible not greater than \$1,000. HACD shall be named upon the certificate issued as an "additional insured," together with providing a copy of the corresponding endorsement evidencing the same.

6.4.1.2 Policy of Professional Liability Insurance or Errors & Omissions coverage, minimum of \$1,000,000 each occurrence, general aggregate minimum limit of \$1,000,000 with a deductible of not greater than \$10,000;

6.4.1.3 Automobile Liability coverage in a combined single limit of \$1,000,000. For every vehicle utilized during the term of this Contract, when not owned by the entity, each vehicle must have evidence of automobile insurance coverage with limits of no less than \$50,000/\$100,000 and medical pay of \$1,000 with a deductible not greater than \$1,000.

6.4.1.4 Worker's compensation coverage evidencing carrier and coverage amount.

6.4.1.5 The Contractor shall provide HACD with current certificate(s)/endorsement(s) evidencing the insurance coverage referenced above. Failure to maintain the above-reference insurance coverage, including naming HACD as an additional insured (where appropriate) during the term(s) of this Contract shall constitute a material breach thereof.

6.4.1.6 Insurance certificate(s)/endorsement(s) shall be delivered to the following person representing HACD:

**Housing Authority of the City of Danbury
2 Mill Ridge Road**



**IFB No. B21003, Plumbing Services
CONTRACT NO. C21003**

**Danbury, CT 06811
Attn: Procurement Director**

6.5 Licensing: The Contractor shall provide to HACD a copy of any required Jurisdiction Business License. Contractor's failure to maintain this license in a current status during the term(s) of this Contract shall constitute a material breach of this Contract.

6.6 Financial Viability and Regulatory Compliance:

6.6.1 The Contractor warrants and represents that its entity is in good standing with all applicable federal, state and local organizations and licensing authorities and that it possesses all requisite licenses to perform the Services required by this Contract. The Contractor further warrants and represents that it owes no outstanding delinquent federal, state or local taxes or business assessments.

6.6.2 The Contractor agrees to promptly disclose to HACD any IRS liens or insurance or licensure suspensions or revocations that may adversely affect its capacity to perform the Services outlined within this Contract. Failure by the Contractor to disclose such information to HACD shall constitute a material breach of this Contract.

6.6.3 The Contractor further agrees to promptly disclose to HACD any change of more than 50% of its ownership and/or any declaration of bankruptcy that the Contractor may undergo during the term(s) of this Contract. Failure of the Contractor to comply with this section shall constitute a material breach of this Contract.

6.6.4 All disclosures required pursuant to this section of the Contract shall be made in writing and submitted to HACD within five (5) days of Contractor's receiving notice of the event requiring disclosure.

7.0 Modification: This Contract shall not be modified, revised, amended or extended except by written addendum, executed by both parties.

8.0 Severability: The invalidity of any provision of this Contract, as determined by a court of competent jurisdiction and/or HUD, shall in no way affect the validity of any other provision herein.



**IFB No. B21003, Plumbing Services
CONTRACT NO. C21003**

9.0 Applicable Laws:

- 9.1 Compliance with Federal and State Laws:** All Services performed by the Contractor, pursuant to this Contract, shall be done in accordance with all applicable Federal, State and local laws, regulations, codes and ordinances.
- 9.2 Jurisdiction of Law:** The laws of the State of Connecticut shall govern the validity, construction and effect of this Contract, unless said laws are superseded by, or in conflict with applicable federal laws and/or federal regulations. This Contract shall be binding upon the parties, their successors and assigns, heirs and beneficiaries. In any state court action, the parties agree that the Superior Court Judicial District of Danbury shall be the appropriate forum for any action relating to this Contract.

10.0 Disputed Billings (Charges):

- 10.1 Procedures:** In the event that HACD disputes any portion of any invoice for Services submitted by Contractor, HACD shall pay the undisputed portion of said invoice and initiate dispute-resolving procedures, as follows:
- 10.1.1** HACD's representative shall formally notify the Contractor of all particulars pertaining to the dispute, and request the Contractor to investigate and promptly provide a written explanation of the issue in dispute.
- 10.1.2** If the dispute cannot be resolved by the Contractor's written response, within 10 business days after notification by HACD, an authorized HACD representative and the Contractor's representative shall meet at a mutually convenient date and time to discuss the matter and attempt to arrive at a resolution.
- 10.1.3** If the authorized HACD representative and the Contractor's representative are unable to resolve the dispute through such discussion within 10 business days of the meeting, HACD shall, within 10 business days thereafter, proceed pursuant to "Disputes" under Form HUD- 5370-C (10/2006), *General Conditions for Non-Construction Contracts*.

11.0 2 CFR §200.326 (i), Procurement: Pursuant to this Contract, HACD and the Contractor each agree to comply with the following provisions issued by the Office of the Secretary, HUD:

- 11.1 Remedies for Contractor Breach:** Pertaining to Contract-related issues, it is the responsibility of both HACD and the Contractor to communicate with each in as clear and complete a manner as possible. If at any time during the term of this Contract HACD or the Contractor is not



**IFB No. B21003, Plumbing Services
CONTRACT NO. C21003**

satisfied with any issue, it is the responsibility of that party to deliver to the other party communication, in writing, fully detailing the issue and corrective action (please note that HACD has the right to issue unilateral addendums to this Contract, but the Contractor does not have the same right). The other party shall, within 10 business days, respond in writing to the other party (however, HACD shall retain the right to, if conditions warrant, require the Contractor to respond in a shorter period of time). Further, HACD shall, at a minimum, employ the following steps in dealing with the Contractor as to any performance issues:

- 11.1.1** If the Contractor is in material breach of the Contract, HACD may promptly invoke the termination clause detailed within Form HUD-5370-C (10/2006), *General Conditions for Non-Construction Contracts—(With or without Maintenance Work)*, which is attached hereto, made a part hereof and incorporated herein by reference and terminate the Contract for cause. Such termination must be delivered to the Contractor in writing and shall fully detail all pertinent issues pertaining to the cause of and justification for the termination.
 - 11.1.2** Prior to termination, HACD may choose to warn the Contractor, verbally or in writing, of any issue of non-compliance or unsatisfactory performance. Such written warning may include placing the Contractor on probation, thereby giving the Contractor a certain period of time to correct the deficiencies or potentially suffer termination. HACD shall maintain in the Contract file a written record of any such warning detailing all pertinent information. If the Contractor does not agree with such action, the Contractor shall have ten 10 business days to dispute or protest, in writing, such action; if he/she does not do so within the 10-day period, he/she shall have no recourse but to accept and agree with HACD's position on the issue. The written protest must detail all pertinent information pertaining to the dispute, including justification detailing HACD's alleged incorrect action(s).
 - 11.1.3** After termination, if the Contractor does not agree with HACD's termination, the Contractor shall have 10 business days to dispute, in writing, such action; if he/she does not do so within the 10-day period, he/she shall have no recourse but to accept and agree with the HACD's position on the issue. The written protest must detail all pertinent information pertaining to the dispute, including justification detailing the HACD's alleged incorrect action(s).
- 11.2 Termination For Cause and Convenience:** As detailed within Clause No. 3 Form HUD-5370-C (10/2006), *General Conditions for Non-Construction Contracts—(With or without Maintenance Work)*, attached hereto, made a part hereof and incorporated herein by reference, HACD may terminate this Contract with or without cause.



**IFB No. B21003, Plumbing Services
CONTRACT NO. C21003**

- 11.3 Reporting:** Both parties hereby agree to comply with any reporting requirements that may be detailed herein.
- 11.4 Patent Rights:** Both parties hereby agree to comply with HUD Bulletin 90-23, which is the (a) Notice of Assistance Regarding Patent and Copyright Infringement.
- 11.5 Copy Rights/Rights in Data:** In addition to the requirements contained within Form HUD-5370-C, Clause No. 5, *General Conditions for Non-Construction Contracts (With or without Maintenance Work)*, HACD has unlimited rights to any data, including computer software, developed by the Contractor in the performance of the Contract specifically:
- 11.6 Access to Records:** Access is guaranteed by both parties, the Federal grantor agency, the Comptroller General of the United States, or any of their duly authorized representatives to any books, documents, papers, and records of the Contractor which are directly pertinent to this Contract for the purpose of making audit, examination, excerpts, and transcriptions.
- 11.7 Record Retention:** Both parties hereby guarantee retention of all required records for three years from the date of final payment for Services and after any other pending matters are closed.
- 11.8 Clean Air Act:** For all Contracts in excess of \$100,000, both parties hereby agree to comply with all applicable standards, orders or requirements issued under section 306 of the Clean Air Act (42 U.S.C. 1857(h), Section 508 of the Clean Water Act (33 U.S.C. 1368), Executive Order 11738, and Environmental Protection Agency regulations (40 CFR Part 15).
- 11.9 Energy Policy and Conservation Act:** Both parties hereby agree to comply with all mandatory standards and policies relating to energy efficiency, which are contained in the state energy conservation plan issued in compliance with the Energy Policy and Conservation Act (Pub. L.94-163, 89 Stat. 871).
- 12.0 Miscellaneous Provisions:**
- 12.1 Non-Escalation:** Unless otherwise specified within the IFB documents, the prices reflected in the Contract shall not increase during the term of the Contract.
- 12.2 Funding Restrictions and Order Quantities:** HACD reserves the right to reduce payment for Services in amounts necessary, without prejudice or liability to HACD, if:
- 12.2.1** funding for Services is not available;



**IFB No. B21003, Plumbing Services
CONTRACT NO. C21003**

- 12.2.2** legal restrictions are placed upon the expenditure of monies for Services or supplies; or,
- 12.2.3** HACD's requirements change after award of the Contract.
- 12.3** Unless otherwise stated in the IFB documents, any and all local, State or Federal permits which are required by Contractor to provide the Services described herein shall be the sole responsibility of the Contractor.
- 12.4 Taxes:** All persons doing business with HACD are hereby made aware that HACD is exempt from paying Connecticut State Sales and Use Taxes and Federal Excise Taxes. A letter of Tax Exemption will be provided upon written request from Contractor.
- 12.5 Government Standards:** It is the responsibility of the Contractor to ensure that all Services conform to all local, State and Federal law concerning safety (OSHA and NOSHA) and environmental control, and any other enacted ordinance, code, law or regulation. The Contractor shall be responsible for all costs incurred for compliance with any such possible ordinance, code, law or regulation. No time extensions shall be granted or financial consideration given to the Contractor for time or monies lost due to violations of any such ordinance, code, law or regulations that may occur.
- 12.6 Work on HACD Property:** If the Services under this Contract involve work by the Contractor on HACD property, the Contractor shall take all necessary precautions to prevent the occurrence of any injury to persons or property while performing the Services and, except to the extent that any such injury is caused solely and directly by HACD's negligence, Contractor shall indemnify HACD, and their officers, agents, servants and employees against all loss which may result in any way from any act or omission of the Contractor, its agents, employees, or sub-contractors arising from said Services.
- 12.7 Official, Agent and Employees of HACD Not Personally Liable:** It is agreed by and between the parties hereto that in no event shall any official, officer, employee, or agent of HACD in any way be personally liable or responsible for any covenant or agreement herein contained whether expressed or implied, nor for any statement, representation or warranty made herein or in any connection with this agreement.
- 12.8 Sub-contractors:** Unless otherwise stated within the IFB documents, the Contractor may not use sub-contractors to accomplish any portion of the Services described within the IFB documents or the Contract without the prior written consent by HACD.
- 12.9 Salaries and Expenses Relating to the Contractors Employees:** Unless otherwise stated within the IFB documents, the Contractor shall pay all salaries and expenses of, and all Federal, Social Security taxes, Federal and State Unemployment taxes, and any similar taxes relating to



**IFB No. B21003, Plumbing Services
CONTRACT NO. C21003**

its employees used in the performance of this Contract. The Contractor further agrees to comply with all Federal, State and local wage and hour laws and all licensing laws applicable to its employees or other personnel furnished under this agreement.

- 12.10 Attorney's Fees:** In the event that litigation is commenced by either party in connection with the enforcement of any provision, term or condition of this Contract, the prevailing party, as judicially proven, shall pay all court costs and other reasonable expenses of such litigation, including reasonable attorneys' fees.
- 12.11 Independent Contractor:** Unless otherwise stated within the IFB documents or the Contract, the Contractor is an independent Contractor. Nothing herein shall create any association, agency, partnership or joint venture between the parties hereto and neither party shall have any authority to bind the other in any way.
- 12.12 Severability:** If any provision of this Contract or any portion or provision hereof applicable to any particular situation or circumstance is held invalid, the remainder of this agreement or the remainder of such provision (as the case may be), and the application thereof to other situations or circumstances shall not be affected thereby.
- 12.13 Waiver of Breach:** A waiver by either party of any term or condition of this Contract in any instance shall not be deemed or construed as a waiver of such term or condition for the future, or of any subsequent breach thereof. All remedies, rights, undertakings, obligations, and agreements contained in this Contract shall be cumulative and none of them shall be in limitation of any other remedy, right, obligation or agreement of either party.
- 12.14 Time of the Essence:** Time is of the essence under this agreement as to each provision in which a time of performance is provided or specified.
- 12.15 Limitation of Liability:** In no event shall HACD be liable to the Contractor for any claim of direct, indirect, incidental, consequential or exemplary damages.
- 12.16 Indemnification:**
- 12.16.1** The Contractor shall indemnify, defend, and hold HACD, its officers, employees, and agents, harmless from and against any and all claims, damages, losses, suits, actions, decrees, judgments, attorney's fees, court costs and other expenses of any kind or character, which are caused by, arise out of, or occur due to any failure of the Contractor to (1) abide by any of the applicable professional standards within its industry, or (2) comply with the terms, conditions, or covenants that are contained in this Contract, (3) comply with the any law, ordinance, or decree; or (4) ensure that the any authorized subContractors abide by the terms of this provision and this Contract; provided,



**IFB No. B21003, Plumbing Services
CONTRACT NO. C21003**

however, that Contractor will not be required to indemnify HACD against any loss or damage which was specifically caused by HACD providing inaccurate information to the Contractor, failing to provide necessary and requested information to the Contractor, or refusal to abide by any recommendation of the Contractor.

12.16.2 Any money due to the Contractor under and by virtue of this Contract, which HACD believes must be withheld from the Contractor to protect HACD, may be retained by HACD so long as it is reasonably necessary to ensure HACD's protection; or in case no money is due, its surety may be held until all applicable claims have been settled and suitable evidence to that effect furnished to HACD provided, however, the Contractor's payments shall not be withheld, and its surety shall be released, if the Contractor is able to demonstrate that it has adequate liability and property damage insurance to protect HACD from any potential claims.

12.16.3 The Contractor shall ensure that any Contractual arrangement with any authorized sub-contractor performing Services pursuant to this Contract shall be in conformance with and shall incorporate the terms and conditions of this Contract including the terms of this indemnity provision. The Contractor guarantees that it will promptly handle and rectify any and all claims for materials, supplies and labor, or any other claims that may be made against it or any of its sub-contractors in connection with the Contract.

12.16.4 The Contractor shall indemnify, defend, and hold HACD, its officers, employees, and agents, harmless from and against any and all claims, damages, losses, suits, actions, decrees, judgments, attorney's fees, court costs and other expenses of any kind or character, which are caused by, arise out of, or occur due to property and personal injury damages.

12.17 Lobbying Certification: Contractor certifies, to the best of its information, knowledge and belief, that:

12.17.1 No Federal appropriated funds have been paid or will be paid, by or on behalf of the undersigned, to any person for influencing or attempting to influence an officer or employee of an agency, a Member of Congress, an officer or employee of Congress, or an employee of a Member of Congress in connection with the awarding of any Federal Contract, the making of any Federal loan, the entering into of any cooperative agreement, or modification of any Federal Contract, grant, loan, or cooperative agreement.

12.17.2 If any funds other than Federal appropriated funds have been paid or will be paid to any person for influencing or attempting to influence an officer or employee of an agency, a Member of Congress, an officer or employee of Congress, or an employee of a Member of Congress in connection with this Federal Contract, grant, loan, or cooperative agreement,



**IFB No. B21003, Plumbing Services
CONTRACT NO. C21003**

the Contractor shall complete and submit Standard Form- LLL, Disclosure Form to Report Lobbying, in an accordance with its instructions.

12.17.3 The Contractor shall require that the language of this certification be included in the award documents for all subawards at all tiers (including sub Contracts, subgrants, and Contracts under grants, loans, and cooperative agreements) and that all sub-recipients shall certify and disclose accordingly.

12.18 Additional Federally Required Orders/Directives: Both parties agree that they will comply with the following laws and directives, where applicable:

12.18.1 Executive Order 11061, as amended, which directs the Secretary of HUD to take all action which is necessary and appropriate to prevent discrimination by agencies that utilize federal funds.

12.18.2 Public Law 88-352, Title VI of the Civil Rights Act of 1964, which provides that no person in the United States shall, on the basis of race, color, national origin or sex, be excluded from participation in, denied the benefits of, or subjected to discrimination under any program or activity which receives federal financial assistance. The HA hereby extends this requirement to the Contractor and its private Contractors. Specific prohibited discriminatory actions and corrective action are described in Chapter 2, Subtitle C, Title V of the Anti-Drug Abuse Act of 1988 (42 U.S.C. 19901 et. seq.).

12.18.3 Public Law 90-284, Title VIII of the Civil Rights Act of 1968., popularly known as the Fair Housing Act, which provides for fair housing throughout the United States and prohibits any person from discriminating in the sale or rental of housing, the financing of housing or the provision of brokerage Services, including in any way making unavailable or denying a dwelling to any person because of race, color, religion, sex or national origin. Pursuant to this statute, HACD requires that the Contractor administer all programs and activities, which are related to housing and community development in such a manner as affirmatively to further fair housing.

12.18.4 The Age Discrimination Act of 1975, which prohibits discrimination on the basis of age.

12.18.5 Anti-Drug Abuse Act of 1988 (42 U.S.C. 11901 et. seq.).

12.18.6 HUD Information Bulletin 909-23 which is the following:

12.18.6.1 Notice of Assistance Regarding Patent and Copyright Infringement;

12.18.6.2 Clean Air and Water Certification; and,



**IFB No. B21003, Plumbing Services
CONTRACT NO. C21003**

12.18.6.3 Energy Policy and Conversation Act.

12.18.7 That the funds that are provided by HACD and HUD hereunder shall not be used, directly or indirectly, to employ, award a Contract to, or otherwise engage the Services of any debarred, suspended or ineligible Contractor, subcontractor, or individual.

12.18.8 That none of the personnel who are employed in the administration of the Services required by this Contract shall, in any way or to any extent, be engaged in the conduct of political activities in violation of Title V, Chapter 15, of the United States Code.

12.18.9 The mention herein of any statute or Executive Order is not intended as an indication that such statute or Executive Order is necessarily applicable nor is the failure to mention any statute or Executive Order intended as an indication that such statute or Executive Order is not applicable. In this connection, therefore each provision of law and each clause, which is required by law to be inserted in this agreement, shall be deemed to have been inserted herein, and this agreement shall be read and enforced as though such provision or clause had been physically inserted herein. If, through mistake or otherwise, any such provision is not inserted or is inserted incorrectly this agreement shall forthwith be physically amended to make such insertion or correction upon the application of either part.

13.0 Section 3 Clause: Section 3 of the HUD Act of 1968 including all of the recent updates are a part of this contract. The contractor agrees to abide by the new requirements at 24CFR Part 75 to provide all hours worked for all persons on the awarded contract as prescribed by the authority.

14.0 Confidentiality: During the term of this contract, the Contractor may come in contact with confidential information crucial to the operation of agency business. Such confidential information may include, without limitation: personal identifiable information, business and financial information, business methods and practices, technology, and other such information deemed as "Confidential Information". The Contractor is expected to keep in strict confidence all non-public information, except to the extent disclosure is required by law, requested by any governmental or regulatory agency or body. Confidential information disclosed shall not be used for personal benefit, or for the benefit of any party with which the Contractor is affiliated. If this contract is terminated, the Contractor will promptly return all documents, records, equipment or other information that disclose confidential information.



**IFB No. B21003, Plumbing Services
CONTRACT NO. C21003**

15.0 Appendices, Exhibits and Schedules:

15.1 The following noted documents are made a part of this Contract and are hereby incorporated by reference:

15.1.1 **Appendix No. 1:** Form HUD-5369B, HUD-5370-C, *General Conditions for Non-Construction Contracts, Section I & II*

15.1.2 **Appendix No. 2:** Equal Employment Opportunity

15.1.3 **Appendix No. 3:** Scope of Services, as agreed up between HACD and the Contractor; including original IFB No. B21003

15.1.4 **Appendix No. 4:** The proposed fee(s) submitted by this Contractor in response to the IFB, or any negotiated fee(s) that resulted thereto, which fee(s) shall apply to each procurement that ensues from this Contract;

15.2 Please note that, in the case of any discrepancy between this Contract and any of the above noted appendices, the requirement(s) detailed within the body of this Contract shall take first precedence, then the requirement(s) detailed within each appendix shall take precedence in the order that they are listed above (meaning, the requirement(s) detailed within the lower listed item may not overrule any requirement(s) detailed within a higher listed item).

16.0 DEFINITIONS

Unless otherwise detailed herein, all references to “days” shall be calendar days (in the case that the last day referenced falls on a Saturday, Sunday or legal holiday, then the period of time shall be automatically extended to include the next work day). Wherever the term HACD is referred to herein, that term shall mean HACD and/or its Affiliates. Also, whenever the term "herein" is referred to, such reference is to this Contract, the appendices and all attachments.

17.0 CERTIFICATIONS: The undersigned representative of each party hereby acknowledges by signature below that they have reviewed the foregoing and understand and agree to abide by their respective obligations as defined herein:

XXXXXXXXXX:



**IFB No. B21003, Plumbing Services
CONTRACT NO. C21003**

By: _____ **Date:** _____

Print: _____

Title: _____

Housing Authority of the City of Danbury:

By: _____ **Date:** _____

Print: _____

Title: _____

SAMPLE

ATTACHMENT F

Boiler Manuals

Series 8HE

<u>Manual Contents</u>	<u>Page</u>
1. Pre-Installation.....	6
2. Boiler Assembly.....	9
3. Water Trim and Piping.....	17
4. Gas Piping.....	22
5. Venting.....	24
6. Electrical.....	27
7. System Start-up.....	30
8. Service.....	34
9. Service Parts.....	40

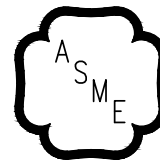

Intertek

H

⚠ WARNING

This manual must only be used by a qualified heating installer/service technician. BEFORE installing, read all instructions in this manual and all other information shipped with the boiler. Post all instructions and manuals near the boiler for reference by service personnel. Perform steps in the order given. Failure to comply could result in severe personal injury, death or substantial property damage.



www.burnhamcommercial.com

IMPORTANT INFORMATION - READ AND SAVE THESE INSTRUCTIONS FOR REFERENCE

All boilers must be installed in accordance with National, State and Local Plumbing, Heating and Electrical Codes and the regulations of the serving utilities. These Codes and Regulations may differ from this instruction manual. Authorities having jurisdiction should be consulted before installations are made. In all cases, reference should be made to the following Standards:

- A. Current Edition of National Fuel Gas Code, NFPA 54/ANSI Z223.1.
- B. Current Edition of American National Standard ANSI/NFPA 211, "Chimneys, Fireplaces, Vents, and Solid Fuel Burning Appliances"; For Venting requirements.
- C. Current Edition of American Society of Mechanical Engineers ASME CSD-1, "Controls and Safety Devices for Automatically Fired Boilers"; for assembly and operations of controls and safety devices.
- D. All wiring on boilers installed in the USA shall be made in accordance with the National Electrical Code, NFPA 70, and/or Local Regulations.

Hazard Definitions

The following defined terms are used throughout this manual to bring attention to the presence of hazards of various risk levels or to important information concerning the life of the product.

DANGER

Indicates a hazardous situation that, if not avoided, will result in death or serious injury.

CAUTION

Indicates a hazardous situation that, if not avoided, could result in minor or moderate injury.

WARNING

Indicates a hazardous situation that, if not avoided, could result in death or serious injury.

NOTICE: Indicates special instructions on installation, operation, or service which are important but not related to personal injury hazards.

 **DANGER****• Explosion Hazard.**

- DO NOT store or use gasoline or other flammable vapors or liquids in the vicinity of this or any other appliance.
- If you smell gas, do not try to operate the burner/boiler system. Do not touch any electrical switch or use any phone in the building. Immediately call the gas supplier from a remotely located phone
- Burner/boiler systems produce steam or hot water in a pressurized vessel by mixing extremely flammable fuels with air to produce combustion and very hot products of combustion. Explosions, fires, severe personal injury, death and/or property damage will result from improper, careless or inadequate installation, operation or maintenance of fuel-burning and boiler equipment.

 **WARNING**

- This boiler requires regular maintenance and service to operate safely. Follow the instructions contained in this manual.
- Improper installation, adjustment, alteration, service or maintenance can cause property damage, personal injury or loss of life. Read and understand the entire manual before attempting installation, start-up operation, or service. Installation and service must be performed only by an knowledgeable, experienced, and skilled installer or service agency.
- This boiler must be properly vented.
- This boiler needs fresh air for safe operation and must be installed so there are provisions for adequate combustion and ventilation air.
- The interior of the venting system must be inspected and cleaned before the start of the heating season and should be inspected periodically throughout the heating season for any obstructions. A clean and unobstructed venting system is necessary to allow noxious fumes that could cause injury or loss of life to vent safely and will contribute toward maintaining the boiler's efficiency.
- Installation is not complete unless a pressure relief valve is installed into the specified tapping on the supply top of appliance - See Section 3, Paragraph C.
- This boiler is supplied with safety devices which may cause the boiler to shut down and not re-start without service. If damage due to frozen pipes is a possibility, the heating system should not be left unattended in cold weather; or appropriate safeguards and alarms should be installed on the heating system to prevent damage if the boiler is inoperative.
- This boiler contains very hot water under high pressure. Do not unscrew any pipe fittings nor attempt to disconnect any components of this boiler without positively assuring the water is cool and has no pressure. Always wear protective clothing and equipment when installing, starting up or servicing this boiler to prevent scald injuries. Do not rely on the pressure and temperature gauges to determine the temperature and pressure of the boiler.
- This boiler contains components which become very hot when the boiler is operating. Do not touch any components unless they are cool.
- Boiler materials of construction, products of combustion and the fuel contain alumina, silica, heavy metals, carbon monoxide, nitrogen oxides, aldehydes and/or other toxic or harmful substances which can cause death or serious injury and which are known to the state of California to cause cancer, birth defects and other reproductive harm. Always use proper safety clothing, respirators and equipment when servicing or working nearby the appliance.
- Failure to follow all instructions in the proper order can cause personal injury or death. Read all instructions, including all those contained in component manufacturers manuals which are provided with the boiler before installing, starting up, operating, maintaining or servicing.
- Keep boiler area clear and free from combustible materials, gasoline and other flammable vapors or liquids.
- Do not operate boiler with control which has been subject to water.
- All cover plates, enclosures and guards must be in place at all times.

⚠ WARNING

- Keep boiler area clear and free from combustible materials, gasoline, and other flammable vapors and liquids.
- This boiler requires regular maintenance and service to operate safely. Follow the instructions contained in this manual.
- Installation, maintenance, and service must be performed only by an experienced, skilled and knowledgeable installer or service agency.
- All heating systems should be designed by competent contractors and only persons knowledgeable in the layout and installation of heating systems should attempt installation of any boiler.
- It is the responsibility of the installing contractor to see that all controls are correctly installed and are operating properly when the installation is completed.
- Installation is not complete unless a pressure relief valve is installed.
- This boiler is NOT suitable for installation on combustible flooring.
- Do not tamper with or alter the boiler or controls. Retain your contractor or a competent serviceman to assure that the unit is properly adjusted and maintained.
- Service boiler at least once a year - preferably at the start of the heating season. The inside of the combustion chamber should also be inspected at the same time. Clean if necessary.
- Have Burner and Controls checked at least once a year or as may be necessitated. Do not operate unit with jumpered or absent controls or safety devices. Do not operate unit if any control, switch, component, or device has been subject to water.
- This boiler is designed to burn natural gas only. Do not use gasoline, crankcase drainings, or any oil containing gasoline. Never burn garbage or paper in this boiler. Do not convert to any solid fuel (i.e. wood, coal). All flammable debris, rags, paper, wood scraps, etc., should be kept clear of the boiler at all times. Keep the boiler area clean and free of fire hazards.

NOTICE:

1. This boiler has a limited warranty, a copy of which is printed on the back of this manual. It is the responsibility of the installing contractor to see that all controls are correctly installed and are operating properly when the installation is complete. The warranty for this boiler is valid only if the boiler has been installed, maintained and operated in accordance with these instructions.
2. Boilers built for installation at altitudes 2,000-5,000 ft. above sea level have been specially orificed to reduce gas input rate 4 percent per 1,000 feet above sea level per the National Fuel Gas Code, NFPA 54/ANSI Z223.1.
3. All Series 8HE cast iron boilers are designed, built, marked and tested in accordance with the ASME Boiler and Pressure Vessel Code, Section IV, Heating Boilers. An ASME Data Label is factory applied to each 8HE jacket, which indicates the boiler Maximum Allowable working Pressure (MAWP). Each cast iron section is permanently marked with the MAWP listed on the boiler's ASME Data Label. The MAWP for all Series 8HE Boiler is 50 psi (Water Only).

It is common and acceptable practice to install these boilers in lower pressure systems, below the boiler MAWP. Therefore, in addition to Safety Relief Valves set for 50 psi, Burnham Commercial also offers Safety Relief Valves set for 30 psi (By Special Order Only).

Important Product Safety Information: Refractory Ceramic Fiber Product

WARNING

Some boiler components use materials that contain refractory ceramic fibers (RCF). RCF has been classified as a possible human carcinogen. When exposed to elevated temperatures, RCF may change into crystalline silica, a known carcinogen. When disturbed as a result of servicing or repair, these substances become airborne and, if inhaled, may be hazardous to your health. Avoid breathing RCF particulates and dust.

Precautionary Measures:

- Do not handle RCF parts or attempt any service or repair work involving RCF without wearing the following protective gear:
 1. A properly fitting National Institute for Occupational Safety and Health (NIOSH)-certified air-purifying respirator with a filter efficiency of at least 95%. Respirator should also include a full facepiece when handling used RCF. Other types of respirators may be required depending on site conditions. Current NIOSH recommendations may be found on the NIOSH website <http://www.cdc.gov/niosh/homepage.html>. NIOSH-approved manufacturers, respirators and associated user instructions are listed on the NIOSH website.
 2. Long sleeved, loose fitting clothing that is sufficiently tight around potential entry points for RCF dust.
 3. Gloves.
 4. Eye protection, such as goggles, safety glasses with side shields, or full facepiece.
- Take steps to assure adequate ventilation.
- Handle RCF carefully to minimize airborne dust. Use hand tools whenever possible.
- Dampen used RCF with light water spray prior to removal to prevent airborne dust.
- Do not use compressed air or dry sweeping for clean-up. Frequently clean work area with a vacuum or by wet sweeping to minimize debris accumulation.
- Vacuum work clothes before leaving work area. Wash work clothes separately from other laundry and rinse washing machine after use to avoid contaminating other clothes.
- Wash all exposed body areas gently with soap and water after contact.
- Discard used RCF components by sealing in an airtight plastic bag or container. Refer to local, regional, state or provincial regulations to identify applicable disposal requirements.

First Aid Procedures:

- Eye contact: Flush with water for at least 15 minutes. **Do not rub eyes.** Seek immediate medical attention if irritation persists.
- Skin contact: Wash affected area gently with soap and water. Do not rub or scratch affected skin. Seek immediate medical attention if irritation persists.
- Nose and throat contact: If these become irritated, leave the area and move to a location with clean fresh air. Drink water and blow nose. Seek immediate medical attention if symptoms persist.

1 Pre-Installation

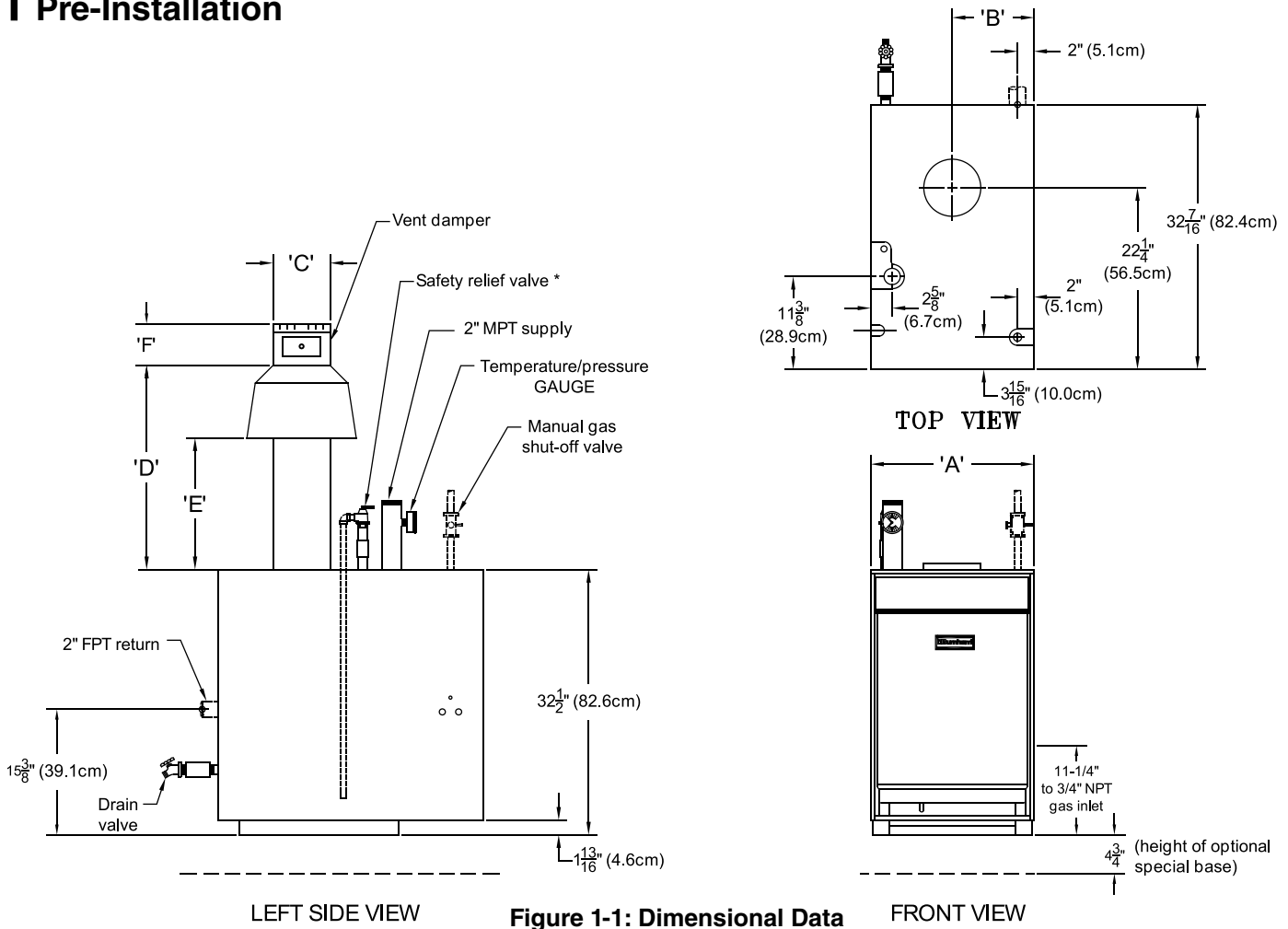

Figure 1-1: Dimensional Data

Table 1-2: Dimensional Data

BOILER MODEL	INPUT (MBH)	DIMENSIONS (INCHES)						WATER CONTENT (GALLONS)	APPROX. SHIPPING WEIGHT (LB)	
		'A'	'B'	'C'	'D'	'E'	'F'		PACKAGED	KNOCKDOWN
805HE	239	20	10	7	21-1/2	11-5/8	6	11.9	600	610
806HE	299	23-3/4	11-7/8	8	27-13/16	18	7-1/8	13.9	690	700

* Maximum allowable working pressure: 50 psi (water only)

1 Pre-Installation *(continued)*

WARNING

Carefully read all instructions before installing boiler. Failure to follow all instructions in proper order can cause personal injury or death.

- A. Inspect shipment carefully for any signs of damage. All equipment is carefully manufactured, inspected and packed. Our responsibility ceases upon delivery of boiler to carrier in good condition. Any claim for damage or shortage in shipment must be filed immediately against carrier by consignee. No claims for variances or shortages will be allowed by Boiler Manufacturer, unless presented within sixty (60) days after receipt of equipment.
- B. Installation must conform to the requirements of the authority having jurisdiction. In the absence of such requirements, installation must conform to the *National Fuel Gas Code*, NFPA 54/ANSI Z223.1. Where required by the authority having jurisdiction, the installation must conform to the *Standard for Controls and Safety Devices for Automatically Fired Boilers*, ANSI/ASME No CSD-1.
- C. Boiler is certified for alcove installation with the following clearances from combustible construction:
 1. Front: 18 in.
 2. Top: 36 in.
 3. Draft hood, rear, sides and flue connector: 6 in.
- D. Provide clearance for servicing and proper operation (following clearances are recommended and may be reduced to minimum clearances shown above):
 1. Single boiler, Front/Top: 24 in. (61.0 cm)
 2. Multiple boiler, Sides: 1 in. (2.5 cm)

WARNING

Appliance is design certified for installation on noncombustible flooring only. For installation on combustible flooring only when installed on special base listed in Table 1-3. Boiler must not be installed on carpeting. When boiler is installed on concrete which is over a material that is subject to melting (PVC, PEX radiant tubing, etc.), the special base must be used. A concrete pad is not sufficient to protect combustible flooring.

Table 1-3: Special Base Required for Installation on Combustible Flooring

Boiler Model	Special Base Part Number
805HE	61816055
806HE	61816065

- E. Install boiler on level floor as close to chimney as possible. For basement installation provide a solid base such as concrete or masonry construction if floor is not level or if water may be encountered on floor around boiler.
- F. Protect gas ignition system components from water (dripping, spraying, rain, etc.) during boiler operation and service (circulator replacement, control replacement, etc.).
- G. Locate boiler to avoid water damage in case there is a leak. If boiler must be located in an area sensitive to water damage, install drain pan underneath boiler and pipe to a suitable drain location. Manufacturer will not be held responsible for water damage resulting from this appliance or any of its components.
- H. Provide combustion and ventilation air in accordance with applicable provisions of local building codes, or the *National Fuel Gas Code*, NFPA 54/ANSI Z223.1, Air for Combustion and Ventilation.
- I. If replacing an existing boiler, check for and correct common system problems including:
 1. System leaks resulting in premature heat exchanger failure from oxygen corrosion or hardness deposits
 2. Inadequate freeze protection resulting in system freezing and leaking
 3. Dirt or debris left in existing piping if it has not been properly flushed or cleaned

WARNING

- Adequate combustion and ventilation air must be provided to assure proper combustion.
- Do not install boiler where gasoline or other flammable vapors or liquids, or sources of hydrocarbons (i.e. bleaches, cleaners, chemicals, sprays, paint removers, fabric softeners, etc.) are used or stored.

NOTICE: Mis-sizing of the boiler with regard to the heating system load will result in excessive boiler cycling and accelerated component failure. Burnham Commercial DOES NOT warrant failures caused by mis-sized boiler applications. DO NOT oversize the boiler to the system.

1 Pre-Installation *(continued)*

- J. For Multiple boiler installations see also Series 8HE Multiple Boiler Application Instructions, 111924-01, available on Burnham Commercial website.
- K. Check for and remove any potential combustion air contaminants from area around boiler. See Table 1-4.

NOTICE: Flue side corrosion caused by contaminants is not covered by warranty.

Table 1-4: Corrosive Combustion Contaminants and Sources

Contaminants to avoid:
Spray cans containing chloro/fluorocarbons (CFC's)
Permanent wave solutions
Chlorinated waxes/cleaners
Chlorine-based swimming pool chemicals
Calcium chloride used for thawing
Sodium chloride used for water softening
Refrigerant leaks
Paint or varnish removers
Hydrochloric acid/muriatic acid
Cements and glues
Antistatic fabric softeners used in clothes dryers
Chlorine-type bleaches, detergents, and cleaning solvents found in household laundry rooms.
Adhesives used to fasten building products and other similar products
Excessive dust and dirt
Areas likely to have contaminants:
Dry cleaning/laundry areas and establishments
Swimming pools
Metal fabrication plants
Beauty shops
Refrigeration repair shops
Photo processing plants
Auto body shops
Plastic manufacturing plants
Furniture refinishing areas and establishments
New building construction
Remodeling areas
Garages with workshops

2 Boiler Assembly

⚠ WARNING

Use precautions and appropriate rigging apparatus when moving heavy objects.

- A. Remove Crate
1. Remove all fasteners at crate skid.
 2. Lift outside container and remove with all other inside protective spacers and bracing.
- B. Remove boiler from skid. See Figure 2-1. Exercise care to avoid dropping boiler.
1. Place boiler in approximate location. Refer to Section 1: Pre-Installation. Remove base hold down bolts.
 2. Using pry bar under rear corner of Base End Panel, raise boiler and install 1½ in. wood blocks under rear corners. Install ¾ in. pipe roller between Base and skid.
 3. Remove 1½ in. wood blocks. Place 3 in. pipe roller on floor behind skid.
 4. Roll boiler off skid. Move skid out of way.
 5. Roll boiler until 3 in. roller is located as shown. Use pry bar to install wood blocks under front corners of base. Remove 3 in. roller.
 6. Lift boiler with pry bar. Remove wood blocks. Lower boiler.
- C. For Packaged Boiler only, proceed to Paragraph E.
- D. Test Section Assembly for leaks before connecting to system and installing controls, trim and jacket. See Figure 2-3 and Table 2-2.
1. Attach pressure gauge capable of indicating 50 psi. Boiler Temperature-Pressure gauge may be used and is located in Water Trim Carton.
For testing gauge may be connected to permanent location in 2 in. NPT supply pipe as shown in Figures 3-4 and 3-5 or may be connected to a tapping that is unused for pressure testing, such as in Tapping C shown in Figure 2-3.
 2. Install purge valve with a hose that runs to a drain in supply tapping or supply pipe.
 3. Install fill valve and piping to Drain Tapping G.
 4. Plug remaining open tappings.
 5. Fill boiler completely with water by venting air through purge valve. Close purge valve and apply water pressure of at least 10 psi but less than 50 psi gauge pressure.

6. Examine boiler for leaks or damage due to shipment or handling.
7. Remove fill valve, purge valve and piping.

⚠ WARNING

Do not use air to leak test boiler.

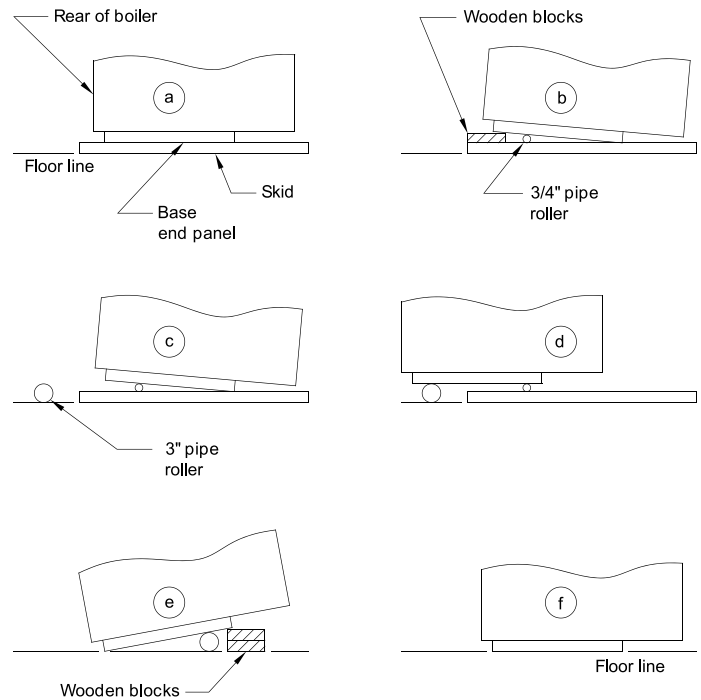

Figure 2-1: Skid Removal

- E. Install special base if installation is on combustible flooring. See Figure 2-4. Floor shield adds 4¾ in. to boiler height.
1. Place special base on combustible floor with surface marked "FRONT" in upward position.
 2. Locate special base with spacing to combustible materials as shown in Figure 2-4.
 3. Place boiler on special base. Boiler must rest inside locating brackets. Boiler jacket panels will overhang special base.
 4. Do not enclose boiler (including special base) on all four sides.
- F. Move boiler to permanent location by sliding or walking. Do not drop.

For Packaged Boiler, proceed to Paragraph L.

⚠ CAUTION

Sheet metal parts may have sharp edges or burrs, use proper Personal Protective Equipment (PPE) during assembly.

2 Boiler Assembly *(continued)*

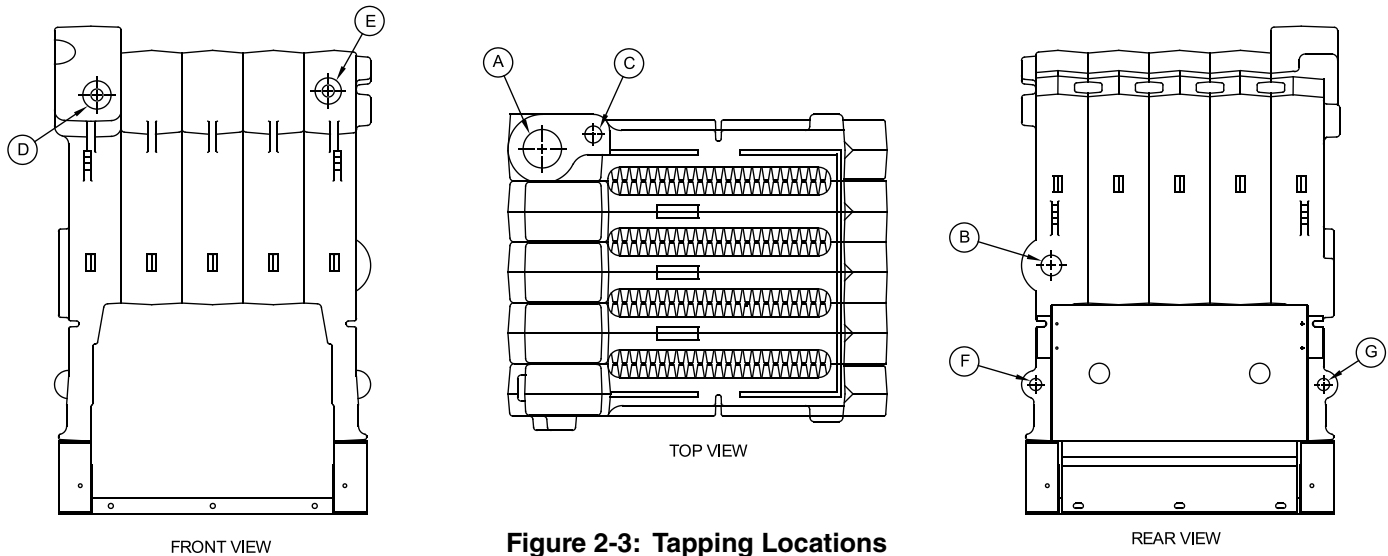

Figure 2-3: Tapping Locations

Table 2-2: Purpose of Tappings

Tapping	Size	Purpose
A	2 in.	Supply
B	2 in.	Return
C	3/4 in.	Relief Valve
D	3/4 in.	HydroStat ® Limit
E	3/4 in.	Opt. Auxiliary L4006E Limit
F	3/4 in.	Washout
G	3/4 in.	Drain

- G. Confirm that one (1) Flue Baffle is properly positioned in each Boiler Flueway. Tabs at the top of each Flue Baffle should be resting on top row of Flue Pins on each adjoining section.
- H. Install Canopy on section assembly. See Figure 2-5. Canopy and hardware are located in Combination Boiler Parts and Control Carton.
1. Place ceramic fiber blanket on top of block assembly perimeter.
 2. Position Canopy on top of Section Assembly. Locate between end sections and sealing ledge on front and back of each section.
 3. Fasten each end with 1/4 in. - 20 x 1 in. carriage bolts, washers and nuts.
- I. Inspect joints between sections. They were factory sealed. If any openings resulted during shipment or handling, reseal with furnace cement. Confirm tie rods are only hand tight to allow for thermal expansion.

- J. Install Base Front Panel. See Figure 2-5. Panel and hardware located in Combination Boiler Parts and Control Carton.
1. Attach Base Front Panel to Section Assembly using 1/4 in. - 20 x 1 1/4 in. carriage bolts, washers and nuts.
 2. Seal between top of Base Front Panel and Section Assembly with furnace cement (shipped in Combination Boiler Parts and Control Carton).
 3. Seal between top of Base Rear Panel and Section Assembly with furnace cement.

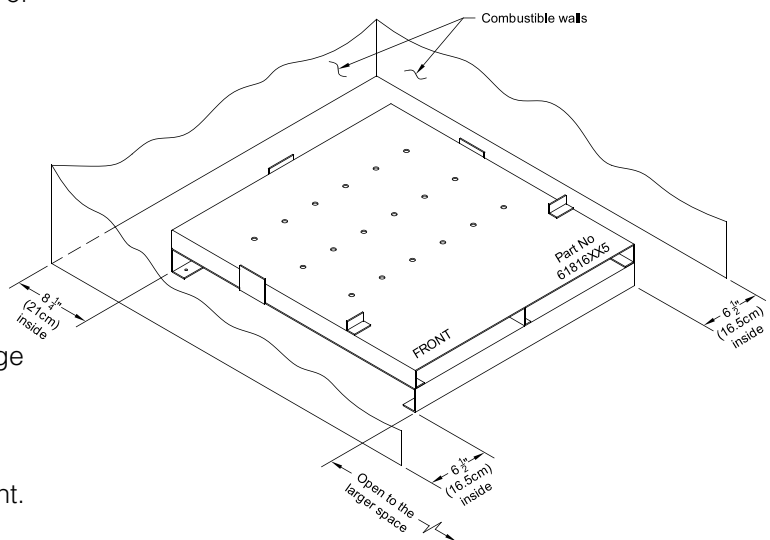

Figure 2-4: Installation of Special Base for Combustible Flooring

2 Boiler Assembly *(continued)*

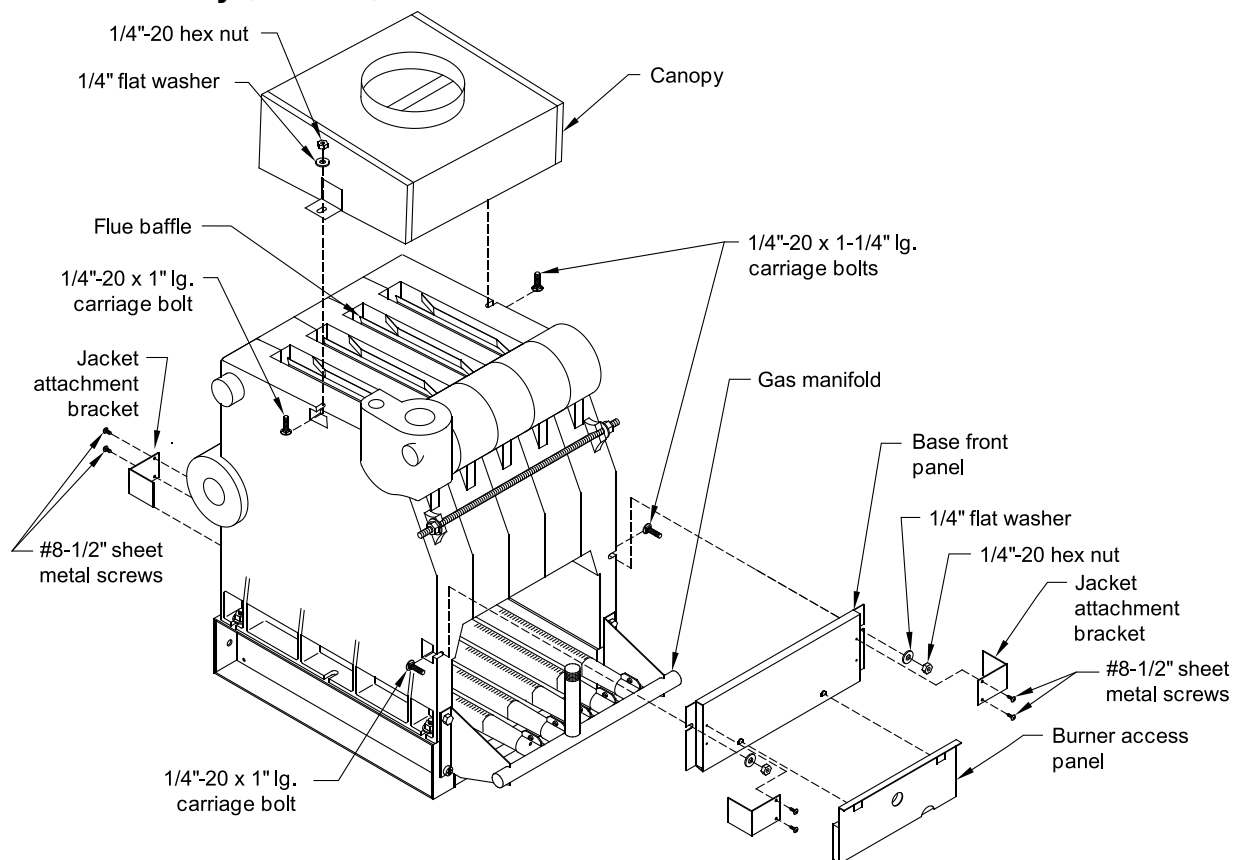

Figure 2-5: General Assembly (Knockdown Boilers)

- K. Install Pilot/Main Burner Assembly. See Figure 2-7. Assembly is located in Combination Boiler Parts and Control Carton. Verify assembly is properly located on support bracket in Base Rear Panel, seated on Main Burner Orifice, and secured with hitch pin clip.
- L. Burner Air Shutters. See Figure 2-7. (On Packaged Boilers, Front Door and Burner Access Panel(s) must be removed to make adjustments.) Initial setting of burner air shutters should be between fully open and approximately 11/16 in. between front edge of Burner Air Shutter and burner mounting ring should be approximately 11/16 in. To adjust this distance, loosen screw at top of air shutter and slide into correct position. Then tighten screw. (Replace Burner Access Panel(s) and Front Door on Packaged Boilers.)
For Packaged Boiler, proceed to Section 3: Water Trim and Piping.
- M. Attach Flame Roll-out Switch to Burner Access Panel. See Figure 2-6. Flame Roll-out Switch and hardware are located in Combination Boiler Parts and Control Carton. Flame Roll-out Switch is a single use device - do not test with heat - switch cannot be reset.
1. Cut insulation from semicircular notch at right end of the burner access panel.
 2. Attach Flame Roll-out Switch Mounting Bracket to burner access panel with (1) #8 x 1/2 in. lg. sheet metal screw.
 3. Attach Flame Roll-out Switch to mounting bracket with (1) #8 x 3/4 in. lg. sheet metal screw.
- N. Install Burner Access Panel(s). Locate Burner Access Panel(s) in Combination Boiler Parts and Control Carton. Engage Burner Access Panel holes with projections on Base Front Panel. See Figure 5.
- O. Install Electro-Well and Immersion Well.
1. Remove 3/4 NPT x 1 in. Electro-Well (black plastic) from Combination Boiler Parts and Control Carton.
 2. Insert Electro-Well in Tapping D. See Figure 2-3.
 3. Insert 3/4 NPT x 3 in. Immersion-Well (brass) in Tapping E. If vertical gas piping is to be installed inside of boiler jacket, it is recommended that second limit be installed in system piping.

2 Boiler Assembly *(continued)*

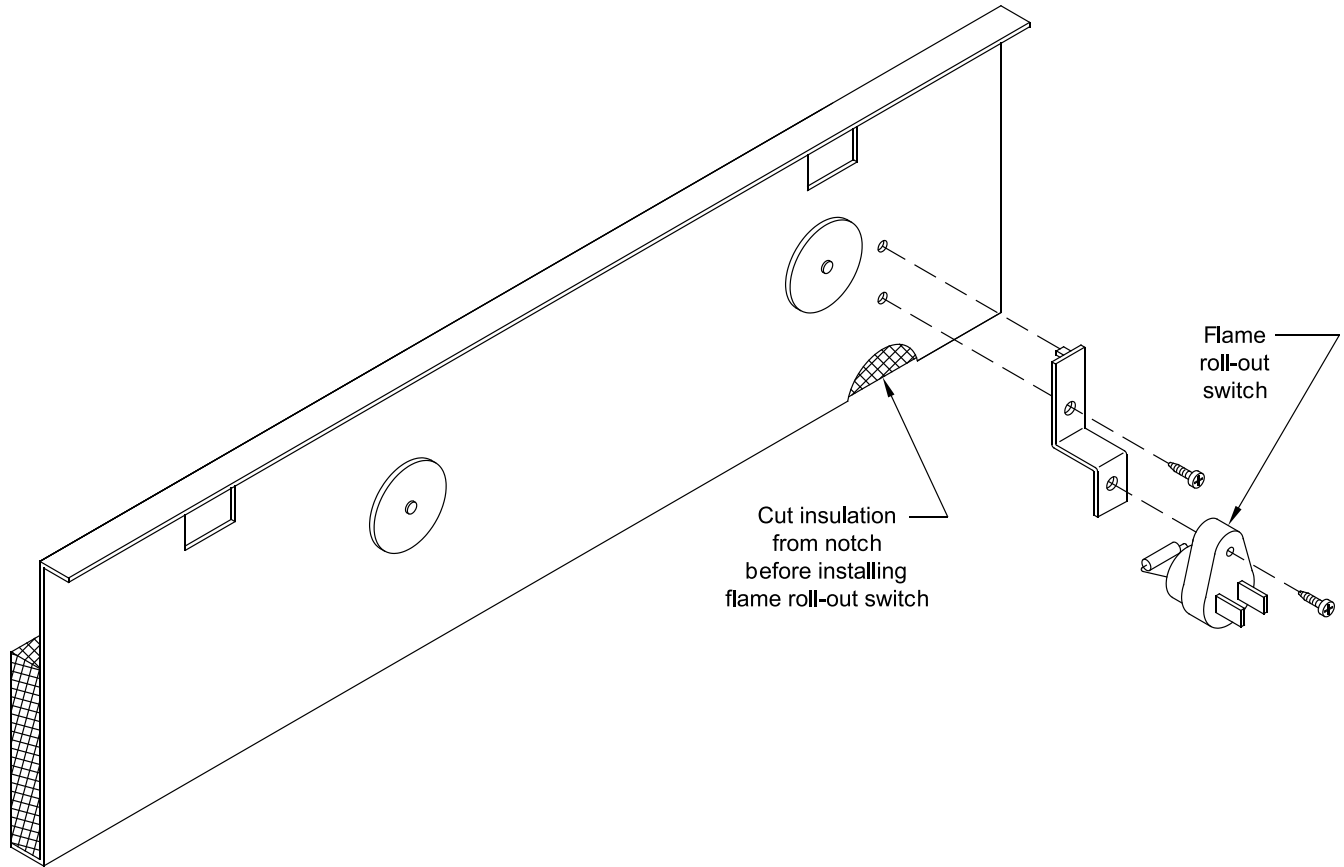

Figure 2-6: Flame Roll-out Switch Installation

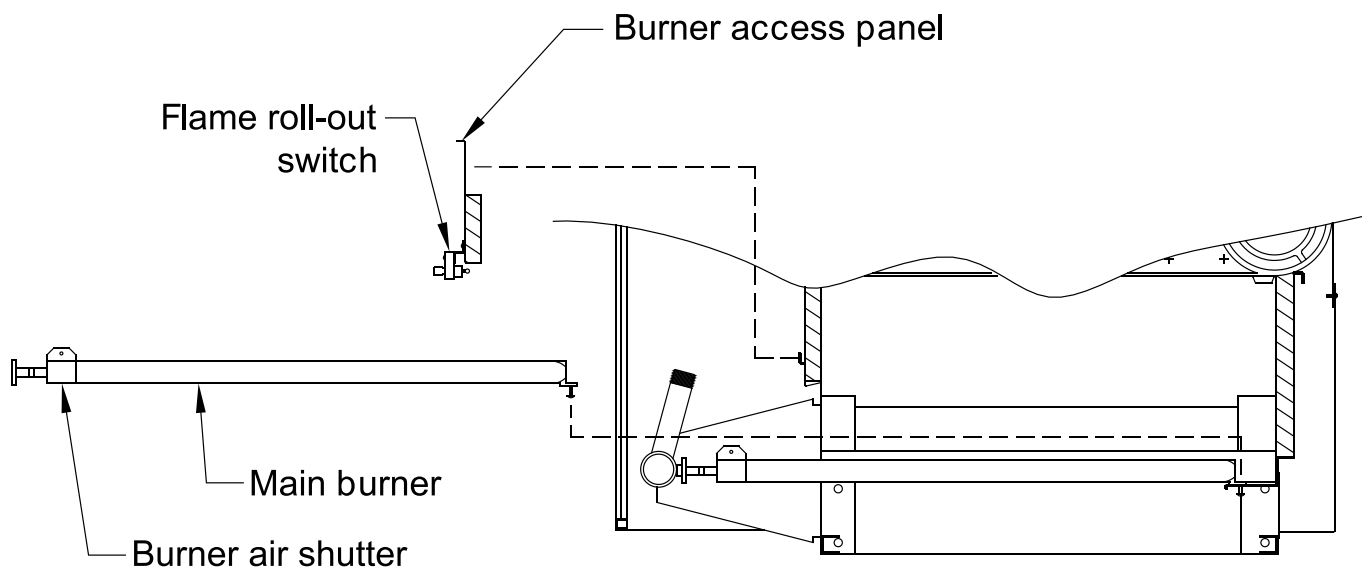

Figure 2-7: Burner/Burner Access Panel Installation

2 Boiler Assembly *(continued)*

P. Install Jacket. See Figure 2-9.

1. Locate four (4) Jacket Attachment Brackets in Combination Boiler Parts and Control Carton. Attach to Front Base Panel and Rear Base Panels with #8 sheet metal screws. See Figure 2-5.
2. Hang Left Side Panel and Right Side Panel onto Jacket Attachment Brackets.
3. Attach Lower Rear Panel to Left and Right Side Panels. Do not tighten sheet metal screws.
4. Attach Upper Rear Panel to Lower Rear Panel. Do not install three (3) upper screws.
5. Remove Rating Label from envelope marked "RATING LABEL ENCLOSED". Remove Combustible Clearance Label from Combination Boiler Parts and Controls Carton. Attach to Vestibule Panel in locations shown.
6. Attach Vestibule Panel to Left Side and Right Side Panels.
7. Attach Lower Front Tie Bar to Left Side and Right Side Panels.
8. Engage Upper Front Panel in slots on Left Side and Right Side Panels. Place Top Panel in position. Attach Top Panel to Left Side, Right Side and Upper Rear Panels.
9. Tighten all jacket screws.
10. Affix Lighting/Operating Instructions Label and Wiring Diagram Label to inside of Front Removable Door. Labels are located in Combination Boiler Parts and Control Carton.

Q. Install Hydrostat 3200 Limit Control.

Locate limit in Combination Boiler Parts and Control Carton, as well as the Hydrostat Remote Mounting Brackets. See Figure 2-8 for location of screw holes on Jacket Vestibule Panel for remote mounting brackets.

1. Attach bottom mounting bracket to Vestibule Panel with two (2) standard truss head jacket screws.
2. Insert the top mounting bracket into the slots on the back of the limit control and rotate the bracket upward.
3. Place the limit control box on to the bottom mounting bracket and attach the top bracket with two (2) more standard truss head jacket screws.
4. Insert limit probe into left immersion well as far as possible and secure with spring clip. (See also HydroStat 3200 manual provided with boiler).

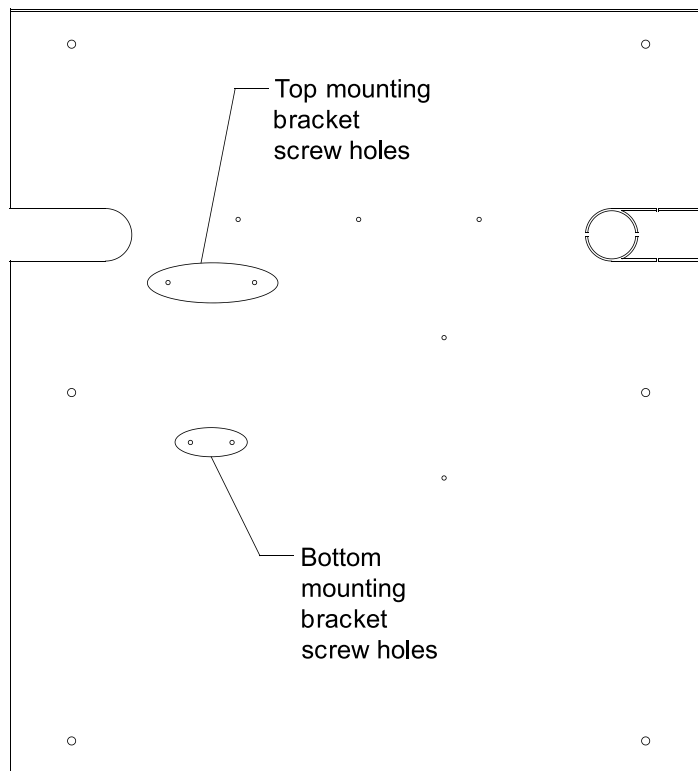

Figure 2-8: Hydrostat 3200 Remote Mounting Screw Holes on Jacket Vestibule Panel

- R. Install Auxiliary Limit or operating control (if used). Insert control probe into right immersion well as far as possible. Tighten screws.
- S. Install Gas Control System. All components are located in Combination Boiler Parts and Control Carton.
 1. Install Gas Control Assembly on Manifold. See Figure 2-10. Use thread (joint) compound (pipe dope) resistant to action of liquefied petroleum gas.
 2. Install pilot burner piping and controls. See Figure 2-11.
- T. Install Ignition Module.
 1. Attach Ignition Control Mounting Bracket to Jacket Vestibule Panel using two (2) #8 x 1/2 in. sheet metal screws.
 2. Attach Honeywell Ignition Module to Mounting Bracket using two (2) #8 x 1/2 in. sheet metal screws.
 3. Connect pilot ground wire and ignitor/sensor lead(s) to ignition module. Refer to "Section 6: Electrical" for connection details.

2 Boiler Assembly *(continued)*

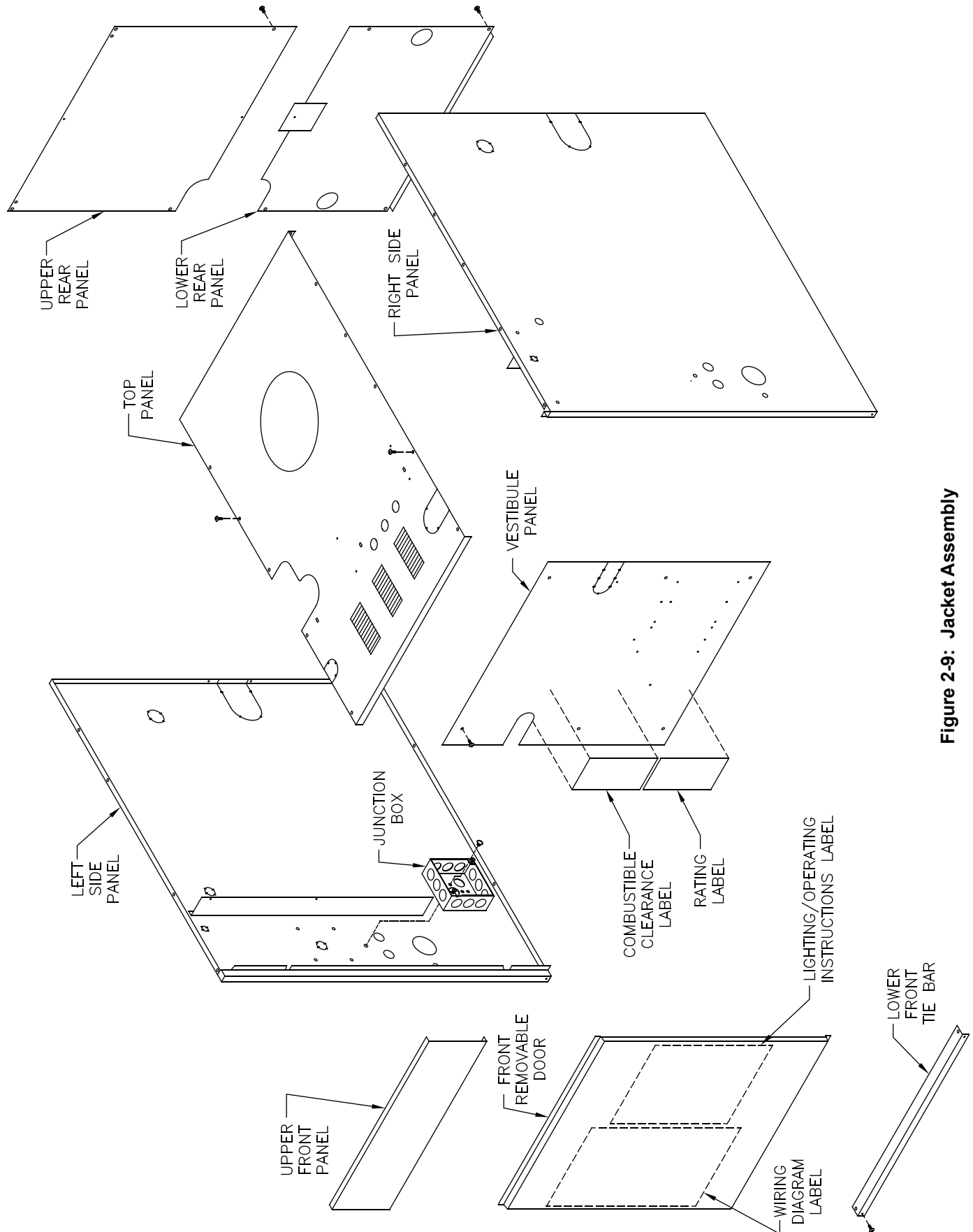

Figure 2-9: Jacket Assembly

2 Boiler Assembly *(continued)*

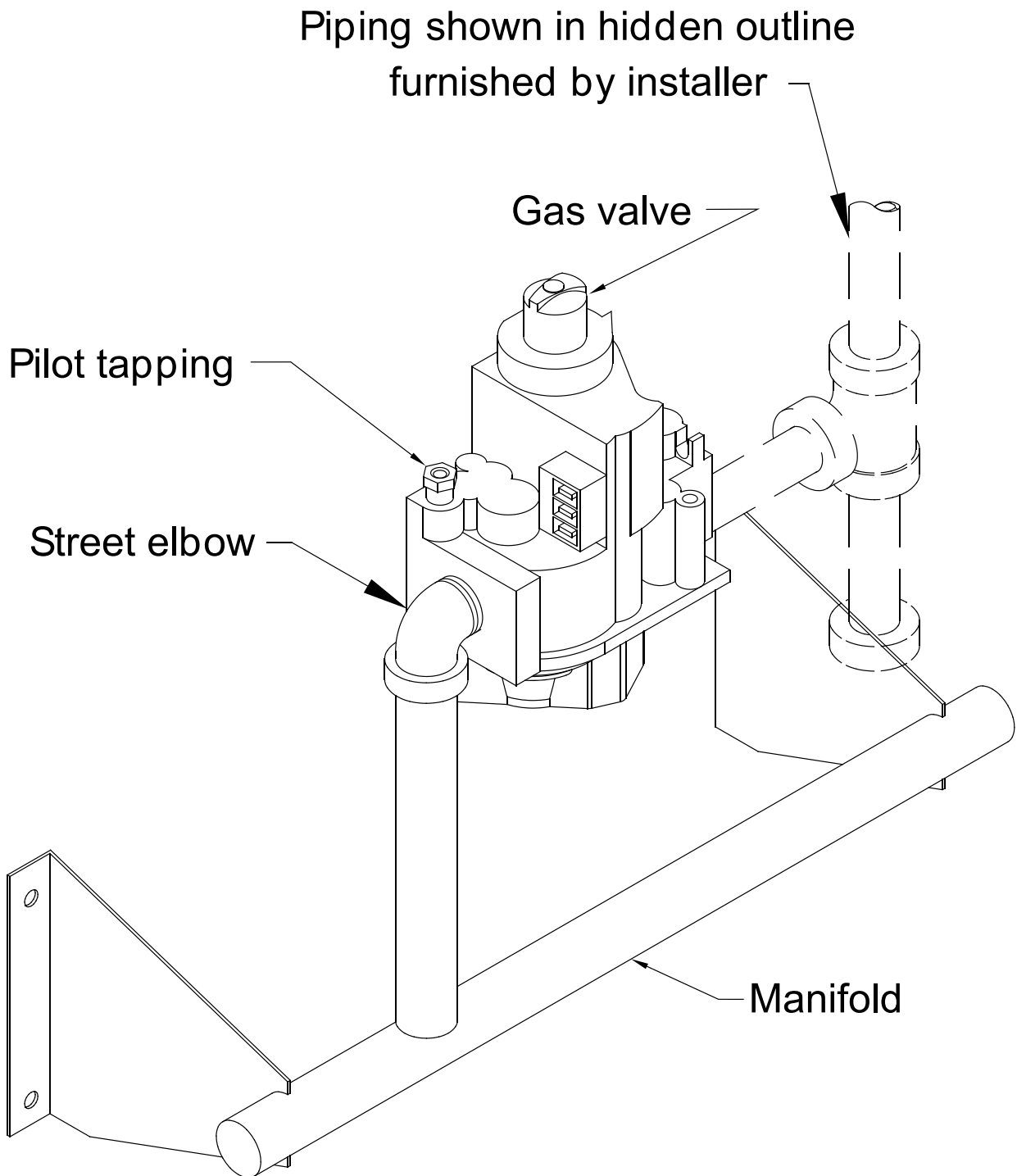

Figure 2-10: Main Gas Piping, Intermittent Ignition

2 Boiler Assembly *(continued)*

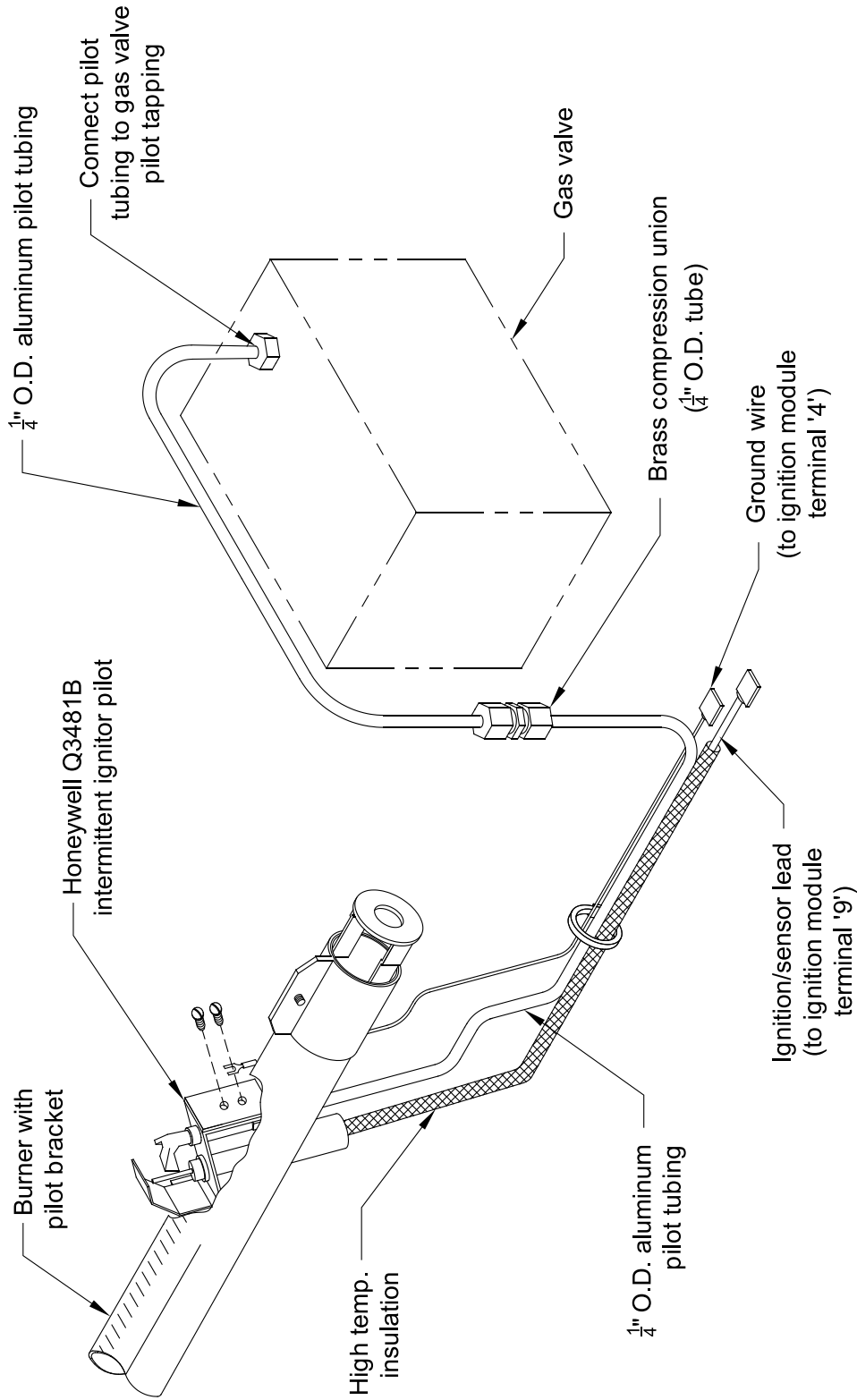

Figure 2-11: Schematic Pilot Piping

3 Water Trim and Piping

WARNING

- Failure to properly pipe boiler may result in improper operation and damage to boiler or structure.
 - Oxygen contamination of boiler water will cause corrosion of iron and steel boiler components, and can lead to boiler failure. Burnham Commercial's Warranty does not cover problems caused by oxygen contamination of boiler water or scale (lime) build-up caused by frequent addition of water.
- A. Design and install boiler and system piping to prevent oxygen contamination of boiler water and frequent water additions.
1. There are many possible causes of oxygen contamination such as:
 - a. Addition of excessive make-up water as a result of system leaks.
 - b. Absorption through open tanks and fittings.
 - c. Oxygen permeable materials in the distribution system.
 2. In order to insure long product life, oxygen sources must be eliminated. This can be accomplished by taking the following measures:
 - a. Repairing system leaks to eliminate the need for addition of make-up water.
 - b. Eliminating open tanks from the system.
 - c. Eliminating and/or repairing fittings which allow oxygen absorption.
 - d. Use of non-permeable materials in the distribution system.
 - e. Isolating the boiler from the system water by installing a heat exchanger.
 - f. Use properly designed and operating air elimination devices in water piping.
- B. Design boiler piping and flow rate to obtain proper temperature rise through the boiler. (See Table 3-1)
- C. Install Safety Relief Valve. See Figure 3-2. Components are located in Water Trim Carton. Safety Relief Valve must be installed with spindle in vertical position.
1. Install $\frac{3}{4}$ in. NPT x $3\frac{1}{2}$ in. lg. nipple in tapping "C". See Figure 2-3.
 2. Install safety relief valve on $\frac{3}{4}$ in. NPT nipple.

WARNING

- Pipe discharge of relief valve to a location where water or steam will not create a hazard or cause property damage if the relief valve opens.
- End of discharge pipe must terminate in an unthreaded pipe.
- If relief valve discharge is not piped to a drain, it must terminate at least 6 inches above floor.
- Termination of the relief valve discharge piping must be in an area where it is not likely to become plugged by debris or subjected to freezing.

DANGER

- Do not install any valves between boiler and relief valve.
- Do not install any valves between relief valve and discharge.
- Do not move relief valve from factory location.
- Do not plug relief valve discharge.
- Do not install a relief valve with a setting greater than 15 psi.

Table 3-1: Flow Rate, Temperature Rise, and Pressure Drop

Boiler Model	Flow Rate (GPM)	Temp. Rise Thru Boiler	Min. Boiler Piping NPT	Boiler Pressure Drop
805HE	20	20° F	1½ in.	3 ft.
	13	30° F	1¼ in.	2 ft.
	10	40° F	1¼ in.	1 ft.
806HE	25	20° F	1½ in.	3 ft.
	17	30° F	1½ in.	2 ft.
	13	40° F	1¼ in.	1 ft.

3 Water Trim and Piping *(continued)*

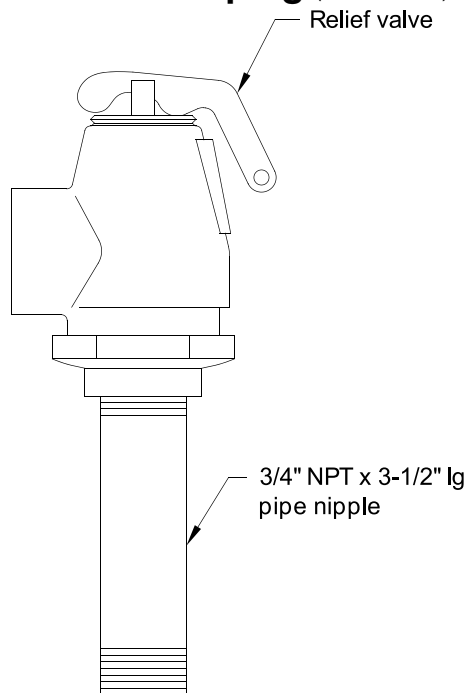

Figure 3-2: Safety Relief Valve Installation

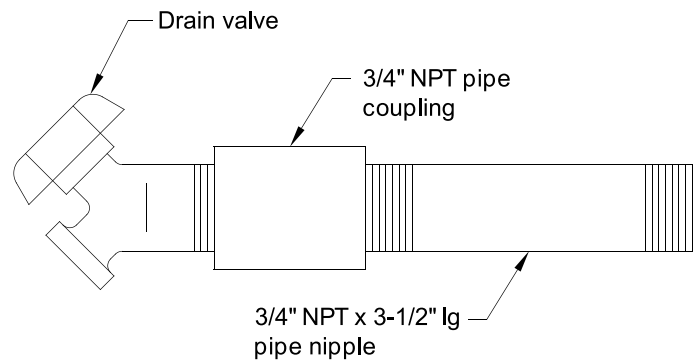

Figure 3-3: Drain Piping Installation

⚠ WARNING

- Burnham Commercial recommends maintaining temperature differential (drop) across the system at 40°F or less and return water temperature at minimum of 135°F.
- Continued boiler operation for prolonged periods of time under conditions when temperature differential across the system exceeds 40°F and/or return water temperature stays below 135°F, may result in premature boiler failure due to flue gas condensation and/or thermal shock.

- D. Install Drain Valve in rear of Left End Section, Tapping "G". See Figure 3-3. Components are located in Water Trim Carton.
- E. Install Temperature-Pressure Gauge. Components are located in Water Trim Carton.
- Standard Temperature - Pressure Gauge Piping. See Figure 3-4.
 - Install 2 in. NPT x 10 in. lg. nipple with gauge tapping into Supply Tapping "A". See Figure 2-3. Gauge tapping should face forward.
 - Insert Temperature-Pressure Gauge. Tighten by applying pressure to square shank on back of gauge. **DO NOT APPLY PRESSURE ON GAUGE CASE** since this may ruin gauge calibration.
 - Alternate Temperature-Pressure Gauge Piping. See Figure 3-5.
 - Install 2 NPT x 10 in. Nipple into Supply Tapping "A". See Figure 2-3.
 - Install 2 NPT x 3/4 NPT x 2 NPT Tee (provided) or 2 NPT x 2 NPT x 3/4 NPT Tee (installer furnished). 3/4 NPT leg should face forward.
 - Install 3/4 NPT x 1/4 NPT Bushing.
 - Insert Temperature-Pressure Gauge. Tighten by applying pressure to square shank on back of gauge. **DO NOT APPLY PRESSURE ON GAUGE CASE** since this may ruin gauge calibration.
- F. Connect system supply and return piping to boiler.
- Maintain minimum 1/2 in. clearance from hot water piping to combustible materials.
 - Pump flow rates and minimum boiler supply and return pipe sizes are shown in Table 3-1.
 - If boiler is used in connection with refrigeration systems, boiler must be installed with chilled medium piped in parallel with heating boiler using appropriate valves to prevent chilled medium from entering boiler. See Figure 3-6.
 - If boiler is connected to heating coils located in air handling units where they may be exposed to refrigerated air, boiler piping must be equipped with flow control valves to prevent gravity circulation of boiler water during cooling system operation. A hot water boiler installed above radiation level must be provided with a low water cutoff device as part of installation. The HydroStat control provided with the boiler includes a low water cut-off function.
 - Continued boiler operation for prolonged periods of time under conditions when temperature differential across the system exceeds 40°F and/or return water temperature stays below 135°F, may result in premature boiler failure due to flue gas condensation and/or thermal shock.

3 Water Trim and Piping *(continued)*

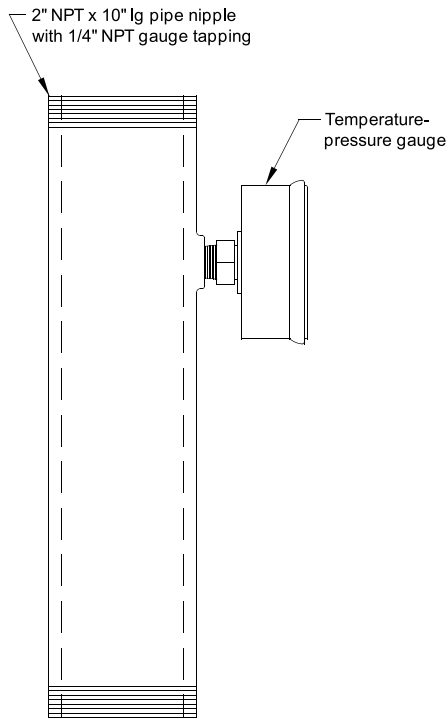

Figure 3-4: Temperature-Pressure Gauge Installation

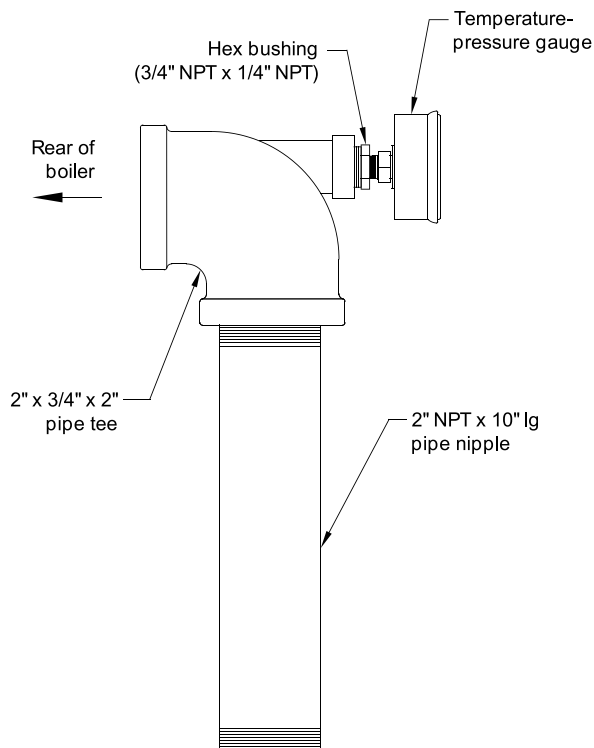

Figure 3-5: Alternate Temperature-Pressure Gauge Installation

Methods to provide boiler water protection are listed below. See also Tekmar Essay #021 "Mixing Methods and Sizing of Variable Speed Injection Pumps", Taco #102-143 Variable Speed Circulator Instruction Sheet, and information from mixing valve manufacturer.

- a. Bypass Piping – Bypass piping is recommended for any installation for improved system temperature balance, while serving to protect the boiler from sustained condensing operation. The bypass also provides some measure of low return water temperature protection by reducing flow through the boiler. See upper part of Figure 3-7.
- b. Bypass Circulator - A bypass circulator is recommended to divert hot supply water into the return when system return temperatures can periodically dip below 135°F. A variable speed circulator is recommended for increased protection. See Figure 3-7 Detail A.
- c. Primary/secondary Piping with Bypass – Primary/Secondary piping is recommended to provide two points of mixing when dual temperature systems are used (i.e. baseboard and radiant heat, outdoor reset and domestic hot water production, systems incorporating night setback or multiple zone pumps on clock schedules). See Figure 3-7, Detail B.
- d. Primary/secondary Piping with 3-way Valve – A 3-way valve with return temperature sensor is recommended to protect the boiler or sensing element from sustained condensing operation, particularly if the system will continuously run below 135°F for extended periods (due to low temperature applications like snow melt, heat pump systems or others). See Figure 3-7, Detail C, and information from mixing valve vendor.

3 Water Trim and Piping *(continued)*

6. A hot water boiler installed above radiation level must be provided with a low water cutoff device as part of installation. The HydroStat control provided with the boiler includes a low water cutoff function.
 7. A start-up strainer is recommended for all installations (new and replacement alike) to prevent system debris and sediment from ending up in the boilers where it will inhibit heat transfer and may eventually cause a cast iron section to crack from overheating.
- G. Indirect Water Heater (if used). Refer to Indirect Installation, Operating and Service Instructions for additional information. Install in same manner as space heating zone.

Water Quality Requirements

pH: 6.0 - 9.5

Total hardness grains / gal: < 7

Chlorides: < 50 ppm

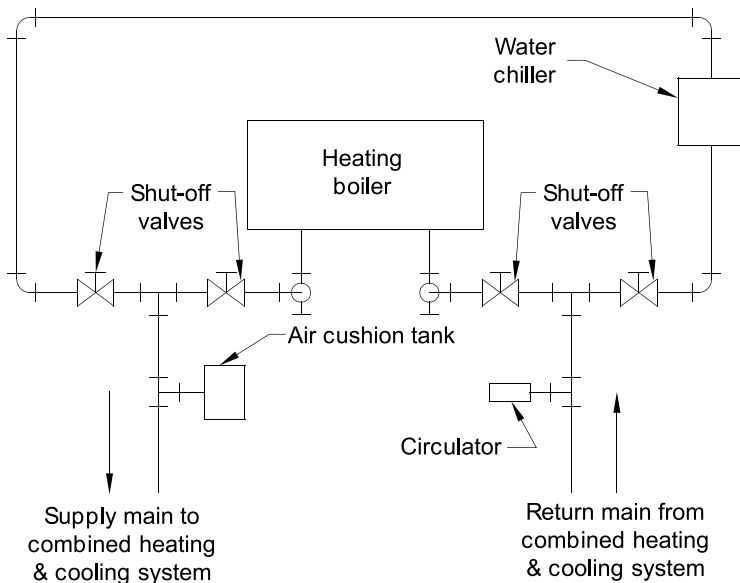
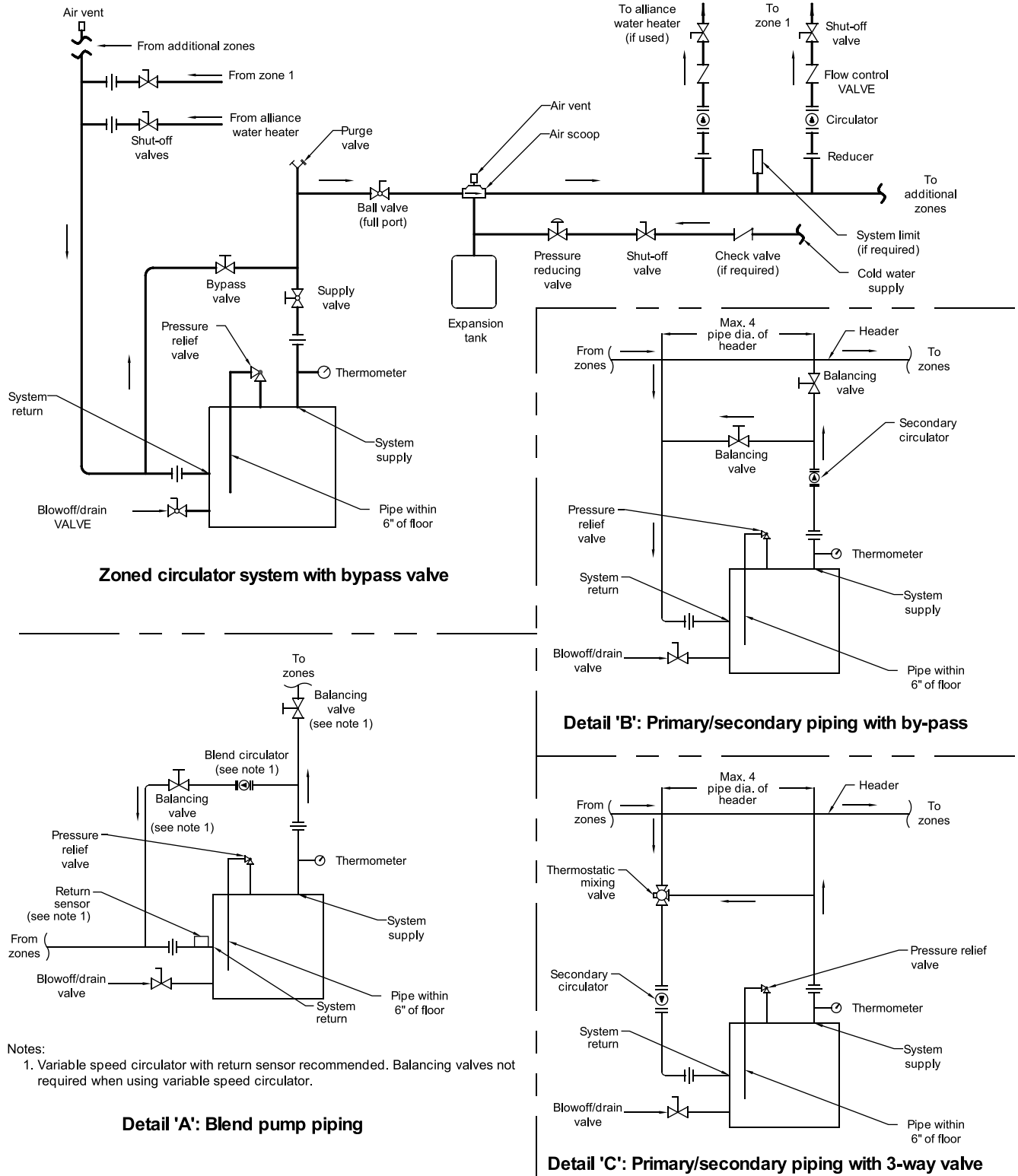

Figure 3-6: Recommended Piping for Combination Heating & Cooling (Refrigeration) System

3 Water Trim and Piping (continued)



Notes:
 1. Variable speed circulator with return sensor recommended. Balancing valves not required when using variable speed circulator.

Figure 3-7: Boiler Piping

4 Gas Piping

WARNING

Failure to properly pipe gas supply to boiler may result in improper operation and damage to the boiler or structure. Always assure gas piping is absolutely leak free and of the proper size and type for the connected load.

An additional gas pressure regulator may be needed. Consult gas supplier.

- A. Size gas Piping. Design system to provide adequate gas supply to boiler. Consider these factors:
1. Allowable pressure drop from point of delivery to boiler. Maximum allowable system pressure is ½ psig. Actual point of delivery pressure may be less; contact gas supplier for additional information. Minimum allowable gas valve inlet pressure is indicated on rating label.
 2. Maximum gas demand. Table 4-1 lists boiler input rate. Also consider existing and expected future gas utilization equipment (i.e. water heater, cooking equipment).
 3. Length of piping and number of fittings. Refer to Table 4-2 for maximum capacity of Schedule 40 pipe. Table 4-3 lists equivalent length for standard fittings.

Table 4-1: Rated Input

Boiler Model	Rated Capacity (cubic feet per hour, Natural Gas)	Gas Connection Size
805HE	239	3/4 in.
806HE	299	3/4 in.

WARNING

- Failure to use proper thread compounds on all gas connectors may result in leaks of flammable gas.
- Gas supply to boiler and system must be shut off prior to installing or servicing boiler gas piping

NOTICE: Boilers built for installation at altitudes from 2,001 feet - 5,000 feet above sea level have been specially orificed to reduce gas input rate 4 percent per 1,000 feet above sea level per the National Fuel Gas Code, NFPA 54/ANSI Z223.1.

- B. Connect boiler gas valve to gas supply system.
1. Use methods and materials in accordance with local plumbing codes and requirements of gas supplier. In absence of such requirements, follow the *National Fuel Gas Code*, NFPA 54/ANSI Z223.1.
 2. Use thread (joint) compound (pipe dope) resistant to action of liquefied petroleum gas.
 3. Install sediment trap, ground-joint union and manual shut-off valve upstream of boiler gas valve and outside jacket. See Figure 4-5.
 4. All above ground gas piping upstream from manual gas valve must be electrically continuous and bonded to a grounding electrode. Do not use gas piping as a grounding electrode. Refer to the *National Electrical Code*, NFPA 70.

DANGER

Explosion Hazard.

Do not use matches, candles, open flames, or other ignition sources to check for leaks. Failure to comply could result in severe personal injury, death or substantial property damage.

- C. Pressure Test. The boiler and its gas connection must be leak tested before placing boiler in operation. Follow National Fuel Gas Code, ANSI Z22.3.1/NFPA 54.

4 Gas Piping *(continued)*

Table 4-2: Maximum Capacity of Schedule 40 Pipe in CFH for Gas Pressures of 0.5 psig or Less

Length (Feet)	0.3 Inch w.c. Pressure Drop				0.5 Inch w.c. Pressure Drop			
	½	¾	1	1¼	½	¾	1	1¼
10	132	278	520	1,050	175	360	680	1,400
20	92	190	350	730	120	250	465	950
30	73	152	285	590	97	200	375	770
40	63	130	245	500	82	170	320	660
50	56	115	215	440	73	151	285	580
60	50	105	195	400	66	138	260	530
70	46	96	180	370	61	125	240	490
80	43	90	170	350	57	118	220	460
90	40	84	160	320	53	110	205	430
100	38	79	150	305	50	103	195	400

Table 4-3: Equivalent Lengths of Standard Pipe Fittings & Valves

Pipe Size	I.D. (Inches)	Valves (Fully Open)				Threaded Fittings			
		Gate	Globe	Angle	Swing Check	90° Elbow	45° Elbow	90° Tee, Flow Through Run	90° Tee, Flow Through Branch
½ in.	0.622	0.35	18.6	9.3	4.3	1.6	0.78	1.0	3.1
¾ in.	0.824	0.44	23.1	11.5	5.3	2.1	0.97	1.4	4.1
1 in.	1.049	0.56	29.4	14.7	6.8	2.6	1.23	1.8	5.3
1¼ in.	1.380	0.74	38.6	19.3	8.9	3.5	1.6	2.3	6.9

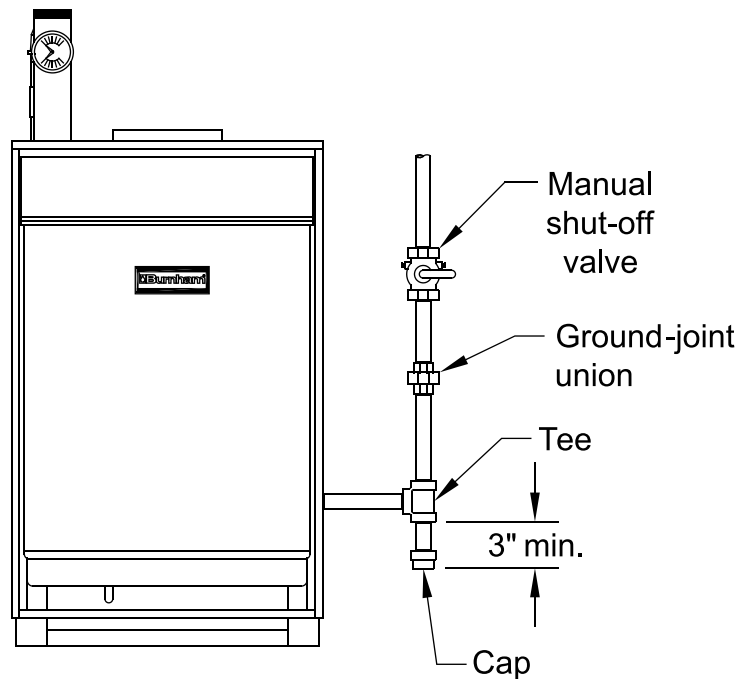

FRONT VIEW

Figure 4-4: Recommended Gas Piping

5 Venting

A. Install vent system in accordance with local building codes; or local authority having jurisdiction; or *National Fuel Gas Code*, ANSI Z223.1/NFPA 54. Install any of the following for this Category I, draft hood equipped appliance:

1. Type B or Type L gas vent. Install in accordance with listing and manufacturer's instructions.
2. Masonry or metal chimney. Build and install in accordance with local building codes; or local authority having jurisdiction; or *Standard for Chimneys, Fireplaces, Vents, and Solid Fuel Burning Appliances*, ANSI/NFPA 211.
Masonry chimney must be lined with approved clay flue lining or listed chimney lining system.
3. Single wall metal vent. Allowed by ANSI Z223.1/NFPA 54 under very restrictive conditions.

B. Avoiding Flue Gas Condensation

⚠ WARNING

- Vent systems must not experience signs of continuous wetness.
- Masonry chimneys, and in particular external masonry chimneys, are more susceptible to the formulation of condensate. If a masonry chimney experiences signs of continuous wetness, a listed metal liner must be installed or an alternate vent system must be used.
- All masonry chimneys must use either a clay tile liner or listed metal liner.
- Recommend use of listed metal chimney liner with external masonry chimneys.
- For external masonry chimneys that do not include a listed metal chimney liner, recommend double wall vent connectors. Use only double wall material on long runs.
- See also Section 3, Water Trim and Piping, for methods to avoid flue gas condensation from low return water temperatures.

C. Inspect chimney and remove any obstructions or restrictions. Clean chimney if previously used for solid or liquid fuel-burning appliances or fireplaces.

⚠ DANGER

Inspect existing chimney before installing boiler. Failure to clean or replace perforated pipe or tile lining will cause severe injury or death.

D. Install Draft Hood on canopy outlet. Maintain height from Jacket Top Panel to Draft Hood skirt as shown in Figure 1-1. DO NOT ALTER, CUT, OR MODIFY DRAFT HOOD.

⚠ WARNING

Do not alter boiler draft hood or place any obstruction or non-approved damper in the breeching or vent system. Flue gas spillage can occur. Unsafe boiler operation will occur.

E. Install Blocked Vent Switch. The Blocked Vent Switch Assembly consists of a strain relief bushing, power cord, and switch attached to mounting bracket. On Packaged boilers, the assembly is shipped attached to top of boiler. On Knocked Down boilers, the assembly is located in Combination Boiler Parts and Control Carton.

1. Uncoil power cord.
2. Position mounting bracket onto lower edge of Draft Hood skirt. Locate center tooth (with #10 sheet metal screw) on outside and other two teeth inside Draft Hood skirt. See Figure 5-1.
3. Slide mounting bracket tight against lower edge of Draft Hood skirt. Position #10 sheet metal screw above skirt's stiffening rib.

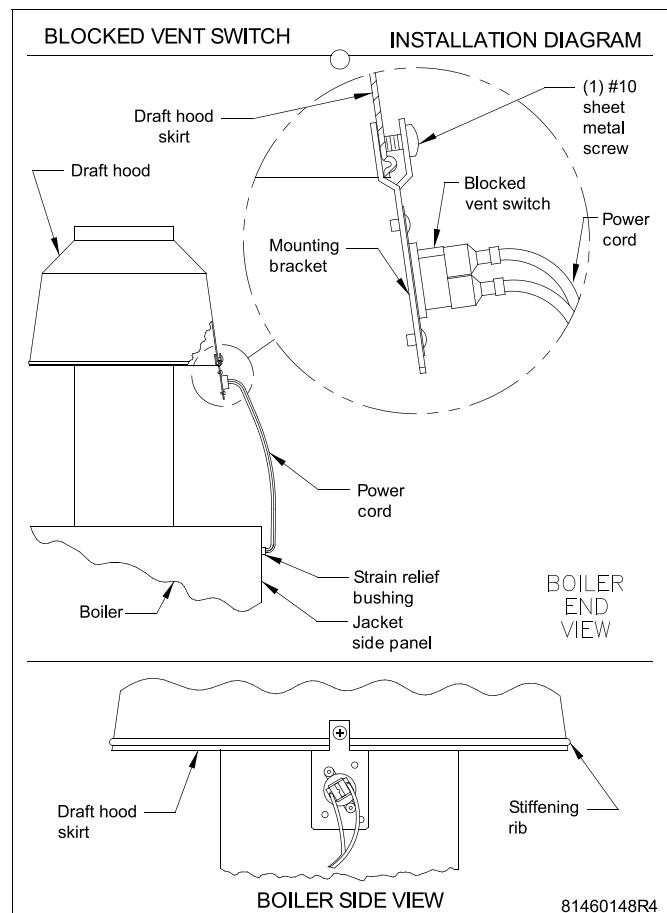

Figure 5-1: Blocked Vent Switch Installation

5 Venting *(continued)*

4. Secure bracket in position by tightening #10 sheet metal screw against outer surface of Draft Hood skirt.
5. Insert excess power cord through Jacket Right Side Panel hole. Remove slack.
6. Position strain relief bushing around power cord. Pinch bushing's two halves together and snap back into hole in Jacket Right Side Panel.
7. Verify power cord, mounting bracket, and Blocked Vent Switch are secure and located as shown in Figure 5-1.

WARNING

- Do not operate boiler without Blocked Vent Switch Properly installed.
- Do not use one vent damper to control two or more heating appliances.

F. Install Vent Damper. See Figure 5-2.

1. Open Vent Damper Carton and remove Installation Instructions. Read Installation Instructions thoroughly before proceeding.
2. Vent damper must be same size as draft hood outlet. See Figure 1-1. Unpack vent damper carefully. Forcing vent damper open or closed may damage gear train and void warranty. Vent damper assembly includes pre-wired connection harness with polarized plug.
3. Mount vent damper assembly on draft hood without modification to either (Refer to instructions packed with vent damper for specific instructions). Vent damper position indicator to be visible to users.

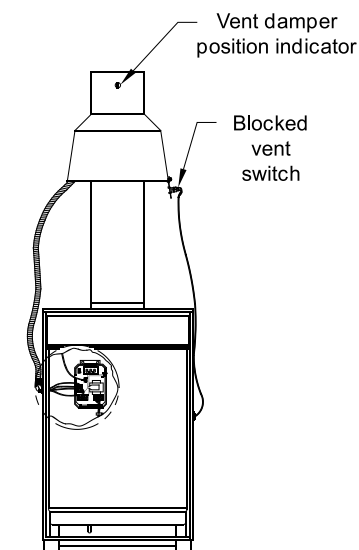
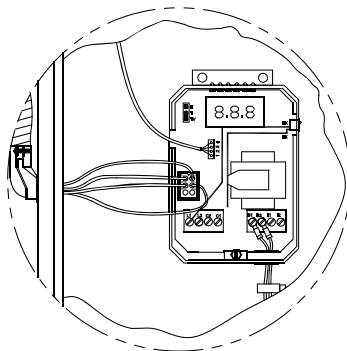
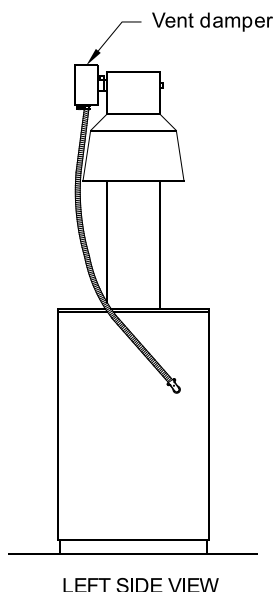

WARNING

Provide adequate clearance for servicing - provide 6 in. minimum clearance between damper and combustible construction.

G. Install Vent Connector from draft hood or vent damper to chimney. See Figure 5-3.

1. Do not connect into same leg of chimney serving an open fireplace.
2. Where two or more appliances vent into a common vent, the area of the common vent should at least equal the area of the largest vent plus 50 % of the area of the additional vents. Do not connect the vent of this appliance into any portion of mechanical draft system operating under positive pressure.
3. Vent connector should have the greatest possible initial rise above the draft hood consistent with the head room available and the required clearance from adjacent combustible building structure.
4. Install vent connector above bottom of chimney to prevent blockage - inspect chimney for obstructions or restrictions and remove - clean chimney if necessary.
5. Vent connector should slope upward from draft hood to chimney not less than one inch in four feet. No portion of vent connector should run downward or have dips or sags. Vent connector must be securely supported.
6. Use thimble where vent connector enters masonry chimney - keep vent connector flush with inside of flue liner.

Figure 5-2: Vent Damper Installation

5 Venting *(continued)*

7. Do not install Non-listed (AGA, CGA, CSA, ETL, or UL) vent damper or other obstruction in vent pipe.
8. Locate Boiler as close to Chimney as possible consistent with necessary clearances. See Section 1: Pre-Installation.
9. Design vent system for sea level input.
10. Provide adequate ventilation of Boiler Room. See Section 1: Pre-Installation.
11. Never pass any portion of vent system through a circulating air duct or plenum.

⚠ WARNING

When an existing boiler is removed from a common venting system, the common venting system is likely to be too large for proper venting of the appliances remaining connected to it.

H. If an Existing Boiler is Removed:

At the time of removal of an existing boiler, the following steps shall be followed with each appliance remaining connected to the common venting system placed in operation, while the other appliances remaining connected to the common venting system are not in operation:

1. Seal any unused openings in the common venting system.
2. Visually inspect the venting system for proper size and horizontal pitch and determine there is no blockage or restriction, leakage, corrosion, or other deficiencies which could cause an unsafe condition.
3. Insofar as is practical, close all building doors and windows and all doors between the space in which the appliances remaining connected to the common venting system are located and other spaces of the building. Turn on clothes dryers and any appliance not connected to the common venting system. Turn on any exhaust fans, such as range-hoods and bathroom exhausts, so they will operate at maximum speed. Do not operate a summer exhaust fan. Close fireplace dampers.
4. Place in operation the appliance being inspected. Follow the Lighting (or Operating) Instructions. Adjust thermostat so appliance will operate continuously.

5. Test for spillage at the draft hood relief opening after 5 minutes of main burner operation. Use the flame of a match or candle, or smoke from a cigarette, cigar or pipe.
6. After it has been determined that each appliance remaining connected to the common venting system properly vents when tested as outlined above, return doors, windows, exhaust fans, fireplace dampers and any other gas-burning appliance to their previous condition of use.
7. Any improper operation of the common venting system should be corrected so the installation conforms with the *National Fuel Gas Code*, NFPA 54/ANSI Z223.1. When resizing any portion of the common venting system, the common venting system should be resized to approach the minimum size as determined using the appropriate tables in the *National Fuel Gas Code*, NFPA 54/ANSI Z223.1.

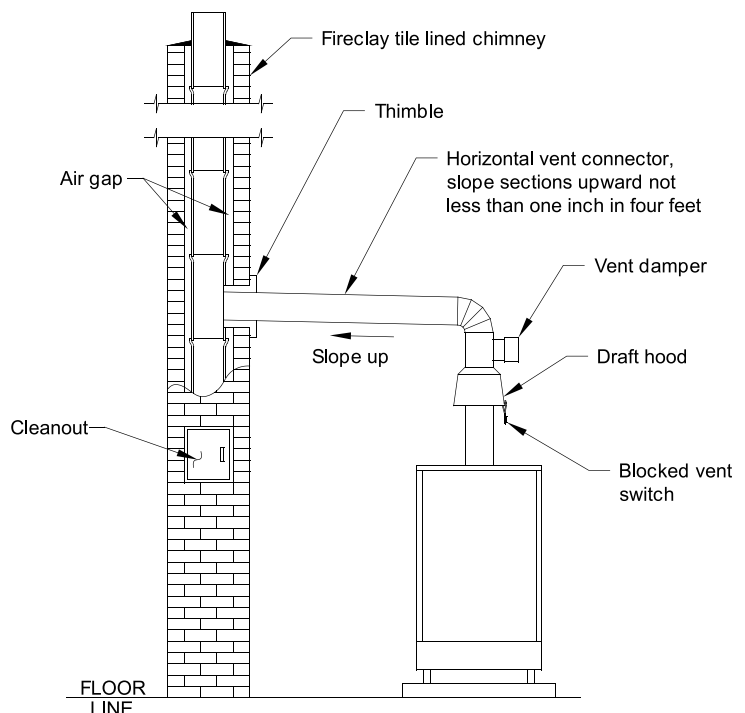

Figure 5-3: Typical Vent System

6 Electrical

DANGER

- Positively assure all electrical connections are unpowered before attempting installation or service of electrical components or connections of the boiler or building
- Lock out all electrical boxes with padlock once power is turned off.
- Electrical power may be from more than one source. Make sure all power is off before attempting any electrical work

WARNING

- Failure to properly wire electrical connections to the boiler may result in serious physical harm.
- Each boiler must be protected with a properly sized fused disconnect.
- Never jump out or make inoperative any safety or operating controls.
- The wiring diagrams contained in this manual are for reference purposes only. Each boiler is shipped with a wiring diagram attached to the front door. Refer to this diagram and the wiring diagram of any controls used with the boiler. Read, understand and follow all wiring instructions supplied with the controls.

A. Install Boiler Wiring

1. Knockdown boilers only. Locate wiring harnesses in Combination Boiler Parts and Control Carton. Refer to Figure 6-1 and connect wiring as shown.
2. Connect supply wiring and electrically ground boiler in accordance with requirements of authority having jurisdiction, or in absence of such requirements the *National Electrical Code*, NFPA 70.

B. Wire Vent Damper.

1. Attach Vent Damper Harness to mounting hole in Jacket Left Side Panel. Install Cable Clamp around flexible conduit and attach to Jacket Top Panel.
2. Plug Vent Damper Harness Plug into Vent Damper Receptacle in Hydrostat 3200 limit control. See Figure 5-2.

C. Install thermostat. Locate on inside wall approximately 4 feet above floor. Do not install on outside wall, near fireplace, or where influenced by drafts or restricted air flow, hot or cold pipes, lighting fixtures, television, or sunlight. Allow free air movement by avoiding placement of furniture near thermostat.

Heat anticipator setting for non-digital thermostats is 0.2 Amp. For digital thermostats that include an adjustable heat anticipator, set anticipator per thermostat manufacturer recommendations. If room heats above thermostat temperature setting, reduce heat anticipator setting. If boiler short cycles without room reaching desired temperature, increase anticipator setting.

D. Wire thermostat. Provide Class II circuit between thermostat and boiler.

E. Alliance Indirect Water Heater (if used).

Refer to *Alliance Indirect Installation, Operating and Service Instructions* for wiring, piping and additional information.

F. Vent Damper Sequence of Operation. See Figure 6-1 for schematic wiring diagram.

1. The Vent Damper is continuously powered at Terminal 1.
2. When there is a call for heat, the damper relay coil is energized through Terminal 5 if all limits ahead of the damper are satisfied.
3. The relay coil closes contacts which energize the damper motor, causing the damper to open.
4. When the damper blade reaches the fully open position, power is sent back to the ignition circuit through Terminal 2 and the damper motor is de-energized.
5. When the call for heat is satisfied, the damper relay coil is de-energized - closing contacts which energize the damper motor. This causes the damper to close. When the damper blade reaches the fully closed position, the damper motor is de-energized.

POWER FAILURE - The damper blade will stop in the position it was in when power failed. (Combustion can never take place unless the damper blade is in the fully open position).

G. Sequence of Operation and Wiring. Refer to next page for Sequence of Operation and Figure 6-1 for wiring.

6 Electrical *(continued)*

Honeywell EI Sequence of Operation

a. Normal Operation

- i.* Thermostat or operating control calls for heat. Vent Damper opens.
- ii.* Ignition Module Terminals PV, MV/PV and the Ignition Terminal are energized. Terminals PV and MV/PV power the Pilot Valve in the Gas Valve supplying gas to the Pilot. The Ignition Terminal supplies voltage to the Ignition Electrode creating an electric spark to ignite the Pilot.
- iii.* The sensing Circuit between the Q3481B Pilot Burner and the IGNITION MODULE proves the presence of the Pilot Flame Electronically and the Ignition Terminal is de-energized.
- iv.* Terminals MV and MV/PV of the IGNITION MODULE are energized and supply power to the Main Gas Valve. The Gas Valve is energized allowing main gas flow, and ignition of Main Burners.
- v.* Call for heat ends. Ignition module is de-energized, de-energizing gas valve, and extinguishing pilot and main flame. Vent Damper closes.

b. Safety Shutdown

- i.* Limit: Automatically interrupts power to the Ignition Module and Gas Valve(s), extinguishing pilot and main flame, when water temperature exceeds set point. Maximum allowable temperature is 250°F. Circulator continues to operate with call for heat, Vent Damper closes. Normal operation resumes when water temperature falls below set point.
- ii.* Blocked Vent Switch: Automatically interrupts main burner operation when excessive flue gas spillage occurs. Circulator continues to operate and Vent Damper remains open with call for heat. If blocked vent switch is activated do not attempt to place boiler in operation. Correct cause of spillage and reset blocked vent switch.

- iii.* Flame Roll-out switch: Automatically interrupts main burner operation when flames or excessive heat are present in vestibule. Circulator continues to operate, Vent Damper remains open with call for heat. Control is single use device. If flame roll-out switch is activated, do not attempt to place boiler in operation. Correct cause of spillage and replace flame roll-out switch.

iv. Pilot

- Pilot failure can occur during the start-up or the operating cycle of the boiler. Any pilot failure of the Q3481B Electronic Pilot, after ignition of pilot flame will close the main gas valve in 0.8 seconds.
- For approximately 90 seconds after failure of the Q3481B pilot, the module through the ignition terminal will try to reestablish pilot flame. If no pilot flame can be sensed by the flame rod circuit, terminals PV and MV/PV are de-energized and the module will lock out on safety. Five to six minutes after shutdown, the IGNITION MODULE restarts the ignition sequence. The ignition trial, shutdown, and wait sequence continues until either the pilot lights or the Thermostat is set below room temperature (to end the call for heat). The ignition sequence can be reset by setting down the Thermostat for one minute.

- c.* Trouble Shooting Guide. See Page 39.

NOTE: See Hydrolevel 3200 instruction manual packed with control for further details on control operation.

6 Electrical (continued)

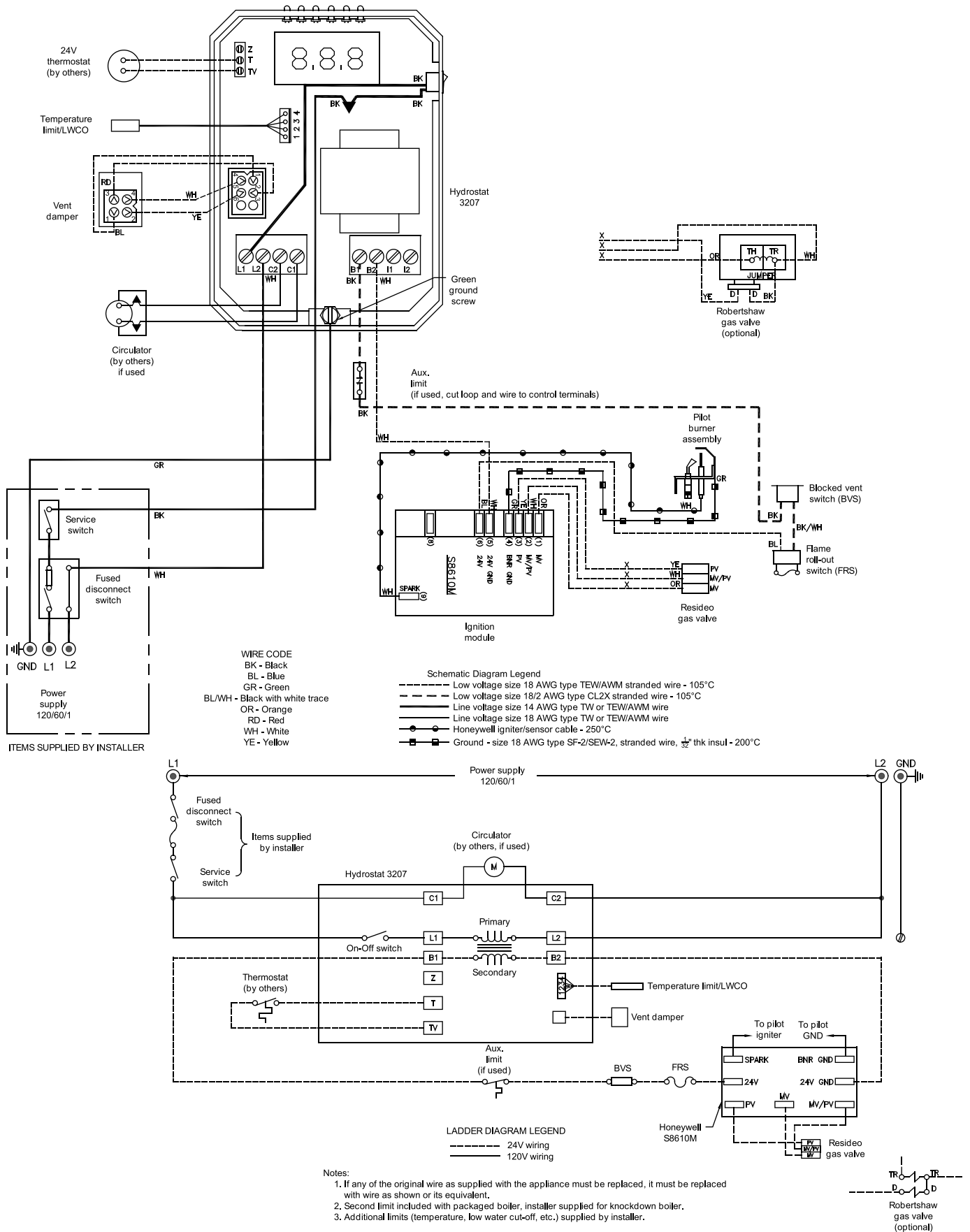

Figure 6-1: Wiring Diagram, Honeywell EI

7 System Start-up

WARNING

- Completely read, understand and follow all instructions in this manual before attempting start-up.
 - Make sure that the area around the boiler is clear and free from combustible materials, gasoline, and other flammable vapors and liquids.
 - Damper must be in open position when appliance main burner is operating.
- A. Safe operation and other performance criteria were met with the gas manifold and control assembly provided on boiler when boiler underwent tests specified in *American National Standard for Gas-Fired Low-Pressure Steam and Hot Water Boilers*, ANSI Z21.13.
- B. Check Main Burners. Main burners must be properly located on support bracket in Base Rear Panel, seated on Main Burner Orifices, and secured with hitch pin clips.
- C. Verify that the venting, water piping, gas piping and electrical system are installed properly. Refer to installation instructions contained in this manual.
- D. Confirm all electrical, water and gas supplies are turned off at the source and that vent is clear of obstructions.
- E. FILL ENTIRE HEATING SYSTEM WITH WATER and vent air from system. Use following procedure on a Series Loop or multi-zoned system installed as per Figure 3-7 to remove air from system when filling.

WARNING

The maximum operating pressure of this boiler is 50 psig. Never exceed this pressure. Do not plug or modify pressure relief valve.

1. Close full port ball valve in boiler supply piping.
2. Isolate all zones by closing zone valves or shut-off valves in supply and return of each zone(s).
3. Attach a hose to the vertical purge valve located prior to the full port ball valve in the system supply piping. (Note - Terminate hose in five gallon bucket at a suitable floor drain or outdoor area).
4. Starting with one circuit at a time, open zone valve or shut-off valve in system supply and return piping.

5. Open purge valve.
 6. Open fill valve (Make-up water line should be located directly after full port ball valve in system supply piping between air scoop and expansion tank).
 7. Allow water to overflow from bucket until discharge from hose is bubble free for 30 seconds.
 8. Close the open zone valve or shut-off valve for the zone being purged of air, then open the zone valve or shut-off valve for the next zone to be purged. Repeat this step until all zones have been purged. At completion, open all zone valves or shut-off valves.
 9. Close purge valve, continue filling the system until the pressure gauge reads the desired cold fill pressure. Close fill valve.
(Note - If make-up water line is equipped with pressure reducing valve, adjust pressure reducing valve to desired cold fill pressure. Follow fill valve manufacturer's instructions).
 10. Open isolation valve in boiler supply piping.
 11. Remove hose from purge valve.
- F. Confirm that the boiler and system have no water leaks.
- G. Prepare to check operation.
1. Obtain gas heating value (in Btu per cubic foot) from gas supplier.
 2. Connect manometer to pressure tap on gas valve. Use 1/8 NPT tapping provided.
 3. Temporarily turn off all other gas-fired appliances.
 4. Turn on gas supply to the boiler gas piping.
 5. Confirm that the supply pressure to the gas valve is 14 in. w.c. or less.
 6. Open the field installed manual gas shut-off valve located upstream of the gas valve on the boiler.
 7. Using soap solution, or similar non-combustible solution, electronic leak detector or other approved method. Check that boiler gas piping, valves, and all other components are leak free. Eliminate any leaks.
 8. Purge gas line of air.
- H. Follow Operating Instructions to place boiler in operation. Refer to label on inside of Front Removable Panel or Figure 7-1.

DANGER

Do not use matches, candles, open flames or other ignition source to check for leaks.



7 System Start-up *(continued)*

FOR YOUR SAFETY READ BEFORE OPERATING

WARNING: If you do not follow these instructions exactly, a fire or explosion may result causing property damage, personal injury, or loss of life.

- A. This appliance is equipped with an ignition device which automatically lights the pilot. Do not try to light the pilot by hand.
- B. BEFORE OPERATING smell all around the appliance area for gas. Be sure to smell next to the floor because some gas is heavier than air and will settle on the floor.
- WHAT TO DO IF YOU SMELL GAS:**
- Do not try to light any appliance.
 - Do not touch any electric switch; do not use any phone in your building.
 - Immediately call your gas supplier from a neighbor's phone. Follow the gas supplier's instructions.
- If you cannot reach your gas supplier, call the fire department.
- C. Use only your hand to turn the gas control knob. Never use tools. If the knob will not turn by hand, don't try to repair it, call a qualified service technician. Force or attempted repair may result in a fire or explosion.
- D. Do not use this appliance if any part has been under water. Immediately call a qualified service technician to inspect the appliance and to replace any part of the control system and any gas control which has been under water.

OPERATING INSTRUCTIONS

1. STOP! Read the safety information above on this label.
2. Set the thermostat to lowest setting.
3. Turn off all electric power to the appliance.
4. This appliance is equipped with an ignition device which automatically lights the pilot. Do not try to light the pilot by hand.
5. Remove front door, if applicable.
6. Locate the gas control valve at the end of the gas supply pipe going into the boiler. The gas control knob is the gray or brown plastic knob located on top of the gas control valve.
7. Rotate gas control knob clockwise  from "ON" position to "OFF". Make sure knob rests against stop.
8. Wait five (5) minutes to clear out any gas. Then smell for gas, including near the floor. If you smell gas, STOP! Follow "B" in the safety information above on this label. If you do not smell gas, go to the next step.
9. Rotate gas control knob counterclockwise  from "OFF" to "ON". Make sure knob rests against stop. Do not force.
10. Replace front door, if applicable.
11. Turn on all electric power to the appliance.
12. Set thermostat to desired setting.
13. If the appliance will not operate, follow the instructions "TO TURN OFF GAS TO APPLIANCE" and call your service technician or gas supplier.

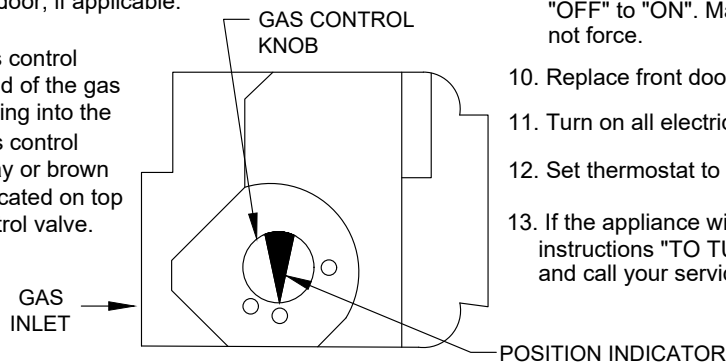

TO TURN OFF GAS TO APPLIANCE

1. Set the thermostat to the lowest setting.
2. Turn off all electric power to the appliance if service is to be performed.
3. Remove front door, if applicable.
4. Rotate gas control knob clockwise  from "ON" position to "OFF". Make sure knob rests against stop.
5. Replace front door, if applicable.

111468-01

Figure 7-1: Operating Instructions

7 System Start-up *(continued)*

CAUTION

- Avoid operating this boiler in an environment where saw dust, loose insulation fibers, dry wall dust, etc. are present. If boiler is operated under these conditions, the burner interior and ports must be cleaned and inspected daily to insure proper operation.
 - Keep hands and feet away from combustion chamber when placing boiler in operation.
- I. Check pilot burner flame and main burner flames through observation port.
1. Check pilot flame. Refer to Figure 7-2 for pilot detail.
 2. Adjust thermostat to highest setting.
 3. Check main burner flames. See Figure 7-3. Flame should have clearly defined inner cones with no yellow tipping. Orange-yellow streaks caused by dust should not be confused with true yellow tipping.
- Yellow-tipping indicates lack of primary air. Improper burner alignment on Main Burner Orifice will also affect primary air injection. Adjust primary air shutter as follows:

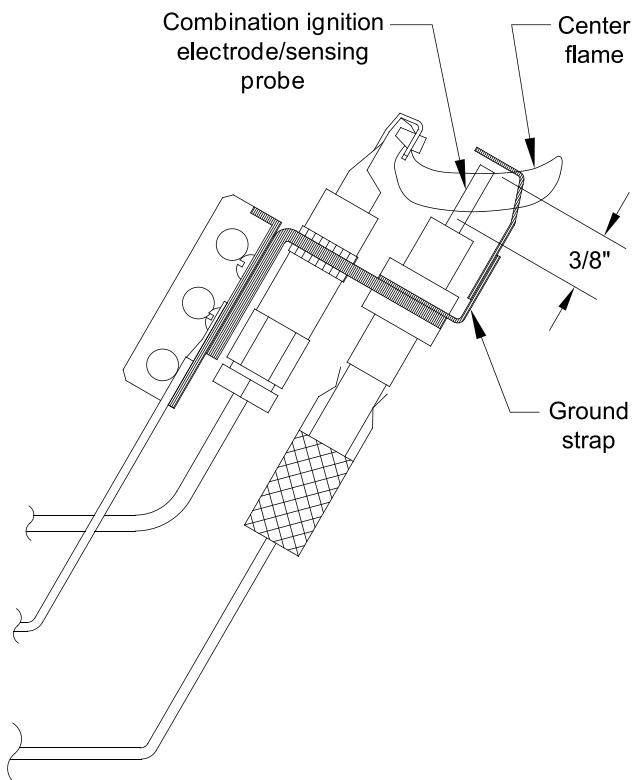

Figure 7-2: Honeywell Q3481B Pilot Flame

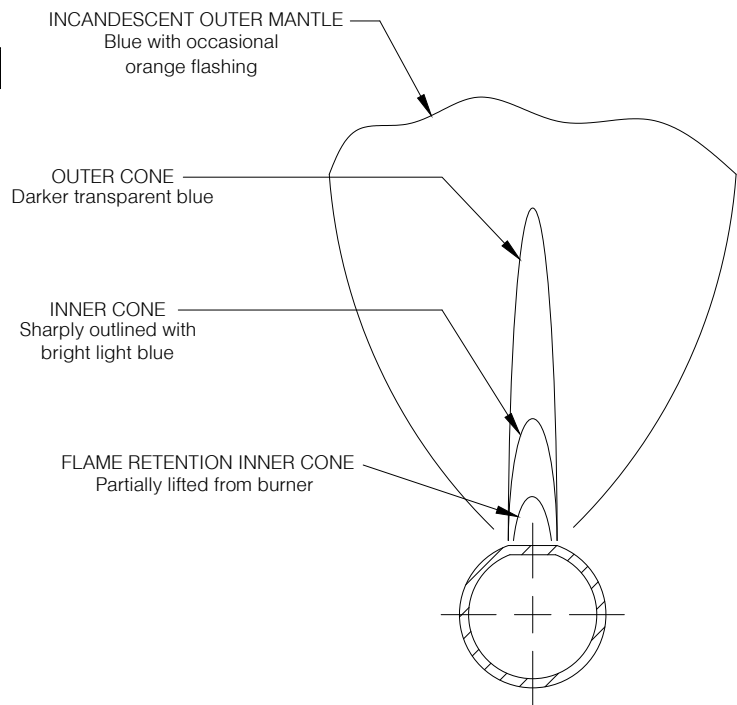

Figure 7-3: Main Burner Flame

- a. Loosen lock screw.
 - b. Close air adjustment until yellow tips appear on flames.
 - c. Slowly open air adjustment until clearly defined inner cones are visible.
 - d. Tighten lock screw.
 - e. Use combustion equipment if adjusting air shutters to less than 11/16 in. opening between front edge of burner air shutter and burner mounting ring.
4. Adjust thermostat to normal setting.
- J. Check thermostat or operating control operation. Raise and lower temperature setting to start and stop boiler operation.
- K. Check ignition system shut-off.
Disconnect ignitor/sensor cable from ignition module. Gas valve must close and pilot and main burners extinguish.
- L. Test LWCO functionality.
1. Press "TEST"/SETTINGS button on Hydrostat 3200. Boiler should shut down.
 2. Set thermostat to call for heat and push "TEST"/SETTINGS button on Htdrostat 3200 to simulate low water condition.
 3. Red "LOW WATER" LED will illuminate and burner will shut down.
 4. Release "TEST"/SETTINGS button and burner will light off.

7 System Start-up *(continued)*

- M. Check high limit function. Set thermostat to higher than normal setpoint. Allow boiler to run until high limit is achieved (180° F default). Burners will shut down. Note - Hydrostat Economy feature may cause boiler to cycle before reaching high limit.
- N. Adjust gas input rate to boiler.
1. Adjust thermostat to highest setting.

Table 7-4: Input Rate

Seconds for One Revolution	Size of Gas Meter Dial			
	One-Half Cu. Ft.	One Cu. Ft.	Two Cu. Ft.	Five Cu. Ft.
30	60	120	240	600
32	56	113	225	563
34	53	106	212	529
36	50	100	200	500
40	45	90	180	450
38	47	95	189	474
40	45	90	180	450
42	43	86	172	430
44	41	82	164	410
46	39	78	157	391
48	37	75	150	375
50	36	72	144	360
52	35	69	138	346
54	33	67	133	333
56	32	64	129	321
58	31	62	124	310
60	30	60	120	300
62	29	58	116	290
64	29	56	112	281
66	29	54	109	273
68	28	53	106	265
70	26	51	103	257
72	25	50	100	250
74	24	48	97	243
76	24	47	95	237
78	23	46	92	231
80	22	45	90	225

2. Check manifold gas pressure. Manifold pressure is listed on rating label. Adjust gas valve pressure regulator as necessary (turn adjustment screw counterclockwise to decrease manifold pressure, or clockwise to increase manifold pressure). If pressure can not be attained, check gas valve inlet pressure. If less than minimum gas supply pressure listed on rating label, contact gas supplier for assistance.
3. Clock gas meter for at least 30 seconds. Use Table 7-4 to determine gas flow rate in Cubic Feet per Hour.
4. Determine Input Rate. Multiply gas flow rate by gas heating value.

WARNING

Failure to properly adjust gas input rate will result in over firing or under firing of the appliance. Improper and unsafe boiler operation may result.

5. Compare measured input rate to input rate stated on rating label.
 - a. Boiler must not be overfired. Reduce input rate by decreasing manifold pressure. Do not reduce more than 0.3 inch w.c. If boiler is still overfired, contact your Burnham Commercial distributor or Regional Office for replacement Gas Orifices.
 - b. Increase input rate if less than 98% of rating plate input. Increase manifold gas pressure no more than 0.3 inch w.c. If measured input rate is still less than 98% of rated input, contact your Burnham Commercial or regional office for larger orifices.
 6. Recheck Main Burner Flame. See Section I
 7. Return other gas-fired appliances to previous conditions of use.
- O. Clean Heating System
- Oil, grease, and other foreign materials which accumulate in new hot water boilers and a new or reworked system should be boiled out, and then thoroughly flushed. A qualified water treatment chemical specialist should be consulted for recommendations regarding appropriate chemical compounds and concentrations which are compatible with local environmental regulations.

7 System Start-up *(continued)*

- P. Check Damper Operation - Vent damper must be in open position when boiler main burners are operating. Start boiler, refer to instructions on damper to determine if damper is in full open position.
- Q. Install Front Removable Panel.
1. Engage top flange (longer of 2 flanges) behind Upper Front Panel.
 2. Swing lower portion of door toward boiler.
 3. Lower door to engage bottom flange behind Lower Front Tie Bar.
- R. Review User's Information Manual and system operation with owner or operator.

IMPORTANT

This boiler is equipped with a feature that saves energy by reducing the boiler water temperature as the heating load decreases. This feature is equipped with an override which is provided primarily to permit the use of an external energy management system that serves the same function. **THIS OVERRIDE MUST NOT BE USED UNLESS AT LEAST ONE OF THE FOLLOWING CONDITIONS IS TRUE:**

- An external energy management system is installed that reduces the boiler water temperature as the heating load decreases.
- This boiler is not used for any space heating.
- This boiler is part of a modular or multiple boiler system having a total input of 300,000 BTU/hr or greater.
- This boiler is equipped with a tankless coil.

8 Service

WARNING

- Service on this boiler should be undertaken only by trained and skilled personnel from a qualified service agency. Inspections should be performed at intervals specified in this manual. Maintain manual in a legible condition.
- Keep boiler area clear and free of combustible materials, gasoline and other flammable vapors and liquids.
- Do not place any obstructions in boiler room that will hinder flow of combustion and ventilation air.
- The service instructions contained in this manual are in addition to the instructions provided by the manufacturer of the boiler components. Follow component manufacturer's instructions. Component manufacturer's instructions were provided with the boiler. Contact component manufacturer for replacement if instructions are missing. Do not install, start up, operate, maintain or service this boiler without reading and understanding all of the component instructions. Do not allow the boiler to operate with altered, disconnected or jumpered components. Only use replacement components identical to those originally supplied by Burnham Commercial.

- A. General. Inspection and service must be conducted annually. Turn off electrical power and gas supply while conducting service or maintenance. Follow instructions TO TURN OFF GAS TO APPLIANCE. See Operating Instructions on inside of Front Removable Door.

DANGER

Explosion Hazard. Electrical Hazard. Shock Hazard. Burn Hazard.

This boiler uses flammable gas, high voltage electricity moving parts, and very hot water under high pressure. Assure that all gas and electric power supplies are turned off and that water temperature is cool before attempting any disassembly for service.

8 Service *(continued)*

CAUTION

- Label all wires prior to disconnection when servicing controls. Wiring errors can cause improper and dangerous operation. Verify proper operation after servicing.
 - Keep hands and feet away from combustion chamber when placing boiler in operation.
- B. Maintenance of Low Water Cut-off. Follow low water cut-off maintenance instructions in HydroStat® manual. If a separate low water cut-off is installed in the piping, follow control manufacturer's instructions.
- C. Vent System. Check for:
1. obstructions
 2. accumulations of soot
 3. deterioration of vent connector, vent accessories, or chimney due to condensation or other reasons
 4. proper support—no sags, particularly in horizontal runs
 5. tightness of joints. Remove all accumulations of soot with wire brush and vacuum
- Remove all obstructions. Replace all deteriorated parts and support properly. Seal all joints.
- D. Remove Main Burners for cleaning, changing orifice plugs, or repairs.
1. Shut down gas boiler in accordance with Operating Instructions on inside of Front Removable Door. Close Manual Shut-off Valve.
 2. Remove Front Removable Door. Raise Lower Front Tie Bar.
 3. Disconnect ignition system.
 7. Hold Main Burner on throat. Lift slightly to raise rear of burner. Push to rear of boiler until burner clears Main Burner Orifice. Lift burners out.
 8. Check burners to be sure they do not contain foreign matter or restrictions. Clean burners with a soft bristle brush, blow any dirt out with compressed air or use a vacuum cleaner. See Figure 8-2.
- E. Inspect Boiler Flueways. Clean if necessary. See Figure 8-2.
1. Shut down gas boiler in accordance with Lighting/Operating Instructions on inside of Front Removable Door. Close Manual Shut-off Valve.
 2. Disconnect vent system. Remove Draft Hood.
 3. Remove Jacket Top Panel.
 4. Remove Canopy from top of boiler.
 5. Remove flue baffles. Refer to Figure 8-2 for instructions on how to remove baffles from flueways. Remove any accumulated scale or soot.
 6. Thoroughly clean flueways with flue brush, removing all scale and soot. See Figure 8-2.
 7. Clean boiler heating surface accessible from combustion chamber with straight handle wire brush.
 8. Reinsert baffles into flueways by reversing steps given in Figure 8-2. Tabs at top of each baffle should rest on top of flue pins.
 9. Install Canopy. See Section 2: Boiler Assembly, Paragraph H.
 10. Install Jacket Top Panel, Draft Hood, Vent Damper and Vent System.
- F. Clean Combustion Chamber by vacuuming. Exercise care to avoid damaging Base Insulation.
- G. Install Burners by reversing procedures used to remove burners. Verify Main Burners are properly located on support bracket in Base Rear Panel, seated on Main Burner Orifices, and secured with hitch pin clips. Verify Main Burner with Pilot Bracket is in proper location. See Table 8-1.
- H. Lubrication. There are no parts requiring lubrication by technician or owner. Circulator bearings are water lubricated.
4. Remove burner access panel(s).
 5. Mark location of Main Burner with Pilot Bracket on manifold.
 6. Remove hitch pin clips from Main Burner Orifices.

CAUTION

Sheet metal parts may have sharp edges or burrs. Use proper Personal Protective Equipment (PPE).

8 Service *(continued)*

Table 8-1: Pilot Burner Location

Boiler Model	Pilot Located Between Burners*
805HE	4 & 5
806HE	5 & 6

* Burners numbered left to right as viewed from front of boiler.

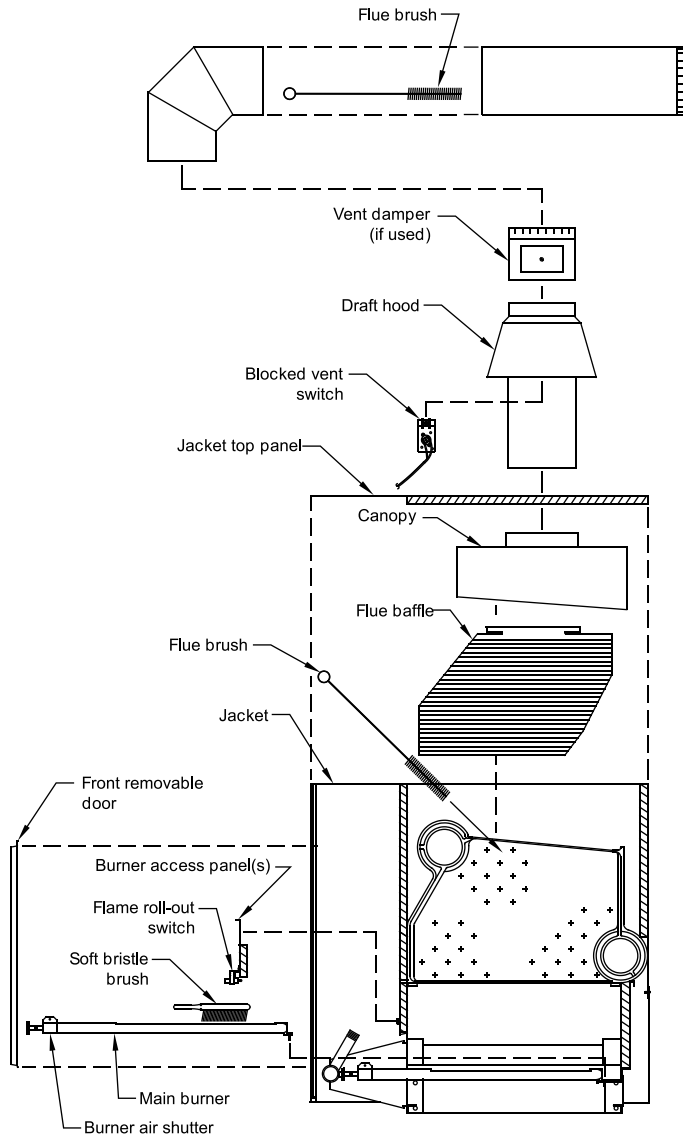

FLUE BAFFLE REMOVAL

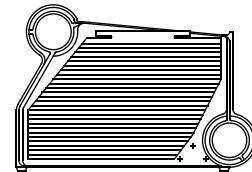

1. Pull up from rear corner of baffle.

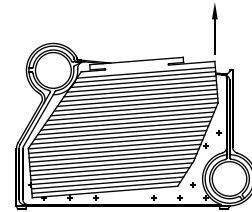

2. Rotate baffle inside flueway while continuing to raise rear corner. It may be necessary to push front of baffle deeper into the flueway to complete the rotation.

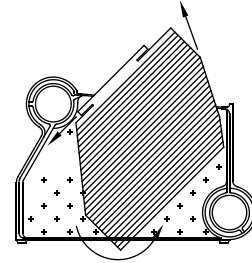

3. Lift baffle out of flueway once edges of the baffle clear the edges of the flueway.

Figure 8-2: Boiler Flueway Cleaning

8 Service (continued)

I. Check Electronic Ignition Module Status

See Figure 8-3 for the location of the status LED on the electronic ignition (EI) module. Table 8-5 provides green LED status codes and recommended service action where applicable. See Figure 8-6 for Troubleshooting Guide.

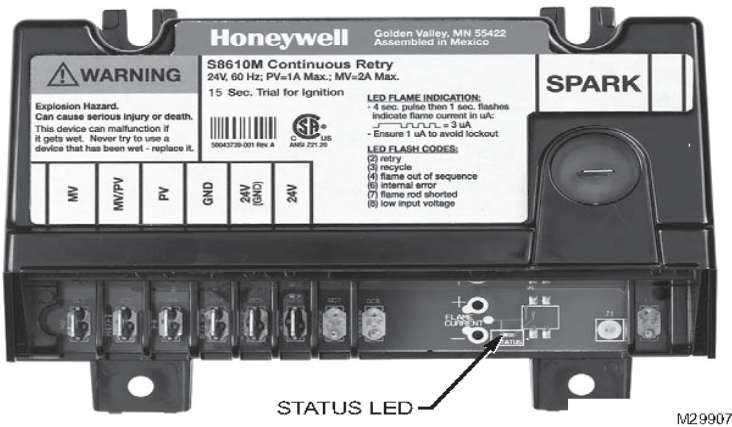

Figure 8-3: Location of LED

J. Flame Current Measurement Procedure

- Pilot flame current in micro amps can be measured using any standard micro-ammeter by inserting meter probes into module hole labeled FLAME CURRENT as shown in Figure 8-4.
- Flame current must be measured with pilot valve open/pilot lit but main valve closed.
- Disconnect MV lead wire from module before measuring flame current. Trying to measure pilot flame current in series with the wiring will not yield accurate reading.
- Minimum steady pilot flame signal must be 1 μ Amp (microampere) DC (direct current).
- For reliable operation flame current should be 2 μ Amp or greater.
- To ensure adequate flame current:
 - Turn off boiler power at circuit breaker or fuse box.
 - Clean the flame rod with emery cloth if required.
 - Make sure electrical connections are clean and tight, and wiring not damaged, repair/replace as needed.
 - Check for igniter/sensor cracked ceramic insulator, replace if needed.
 - Check pilot flame. It must be blue, steady and envelop flame sensing rod 3/8 in. to 1/2 in.

- If needed, adjust pilot flame by turning the gas valve pilot adjustment screw clockwise to decrease or counterclockwise to increase pilot flame. Always reinstall pilot adjustment screw cover and tighten securely upon completion to assure proper gas valve operation.
- Reconnect MV lead wire to module upon satisfactory completion of pilot flame current measurement.
 - Check pilot burner operation/ignition sequence during ignition cycle:
 - Restore boiler power at circuit breaker or fuse box.
 - Set thermostat to call for heat.
 - Watch ignition sequence at burner.
 - If spark does not stop after pilot lights, replace ignition module.
 - If main burners do not light or if main burners light but system locks out, check the module ground wire and gas control as described in the Honeywell Electronic Ignition Troubleshooting Guide, Figure 8-6.

K. Check operation. Refer to Section 7: System Start-up.

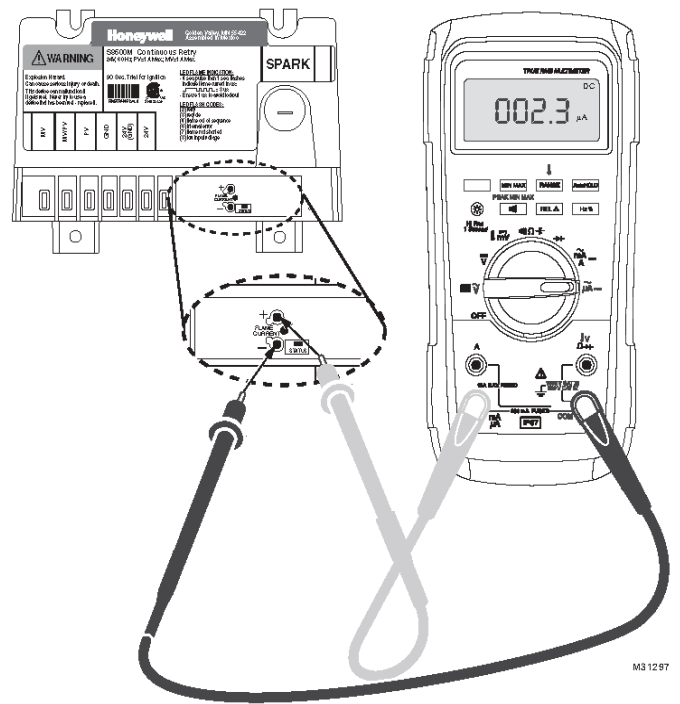

Figure 8-4: Measuring Pilot Flame Current with Micro-ammeter

8 Service *(continued)*

Table 8-5: Green LED Flame Codes

Green LED Flash Code*	Indicates	Next System Action	Recommended Service Action
OFF	No "Call for Heat"	N/A	None
Flash Fast	Power up - internal check	N/A	None
Heartbeat	Normal startup - ignition sequence started (including prepurge)	N/A	None
4 Seconds ON then "x" flashes	Device in run mode. "x" = flame current to the nearest μA	N/A	None
2	5 minute Retry Delay - Pilot flame not detected during trial for ignition	Initiate new trial for ignition after retry delay completed.	If system fails to light on next trial for ignition check gas supply, pilot burner, spark and flame sense wiring, flame rod contamination or out of position, burner ground connection.
3	Recycle - Flame failed during run	Initiate new trial for ignition. Flash code will remain through ignition trial until flame is proved.	If system fails to light on next trial for ignition, check gas supply, pilot burner, flame sense wiring, contamination of flame rod, burner ground connection.
4	Flame sensed out of sequence	If situation self corrects within 10 seconds, control returns to normal sequence. If flame out of sequence remains longer than 10 seconds, control will resume normal operation 1 hour after error is corrected.	Check for pilot flame. Replace gas valve if pilot flame present. If no pilot flame, cycle "Call for Heat." If error repeats, replace control.
6	Control Internal Error	Control remains in wait mode. When fault corrects, control resumes normal operation.	Cycle "Call for Heat". If error repeats, replace control.
7	Flame rod shorted to ground	Control remains in wait mode. When fault corrects, control resumes normal operation.	Check flame sense lead wire for damage or shorting. Check that flame rod is in proper position. Check flame rod ceramic for cracks, damage or tracking.
8	Low secondary voltage supply- (below 15.5 VAC)	Control remains in wait mode. When fault corrects, control resumes normal operation.	Check transformer and AC line for proper input voltage to control. Check with full system load on the transformer.

*Flash Code Descriptions:

- Flash Fast: rapid blinking
- Heartbeat: Constant ½ second bright, ½ second dim cycles.
- 4 second solid on pulse followed by "x" 1 second flashes indicates flame current to the nearest μA . This is only available in run mode.
- A single flash code number signifies that the LED flashes X times at 2Hz, remains off for two seconds, and then repeats the sequence.

8 Service (continued)

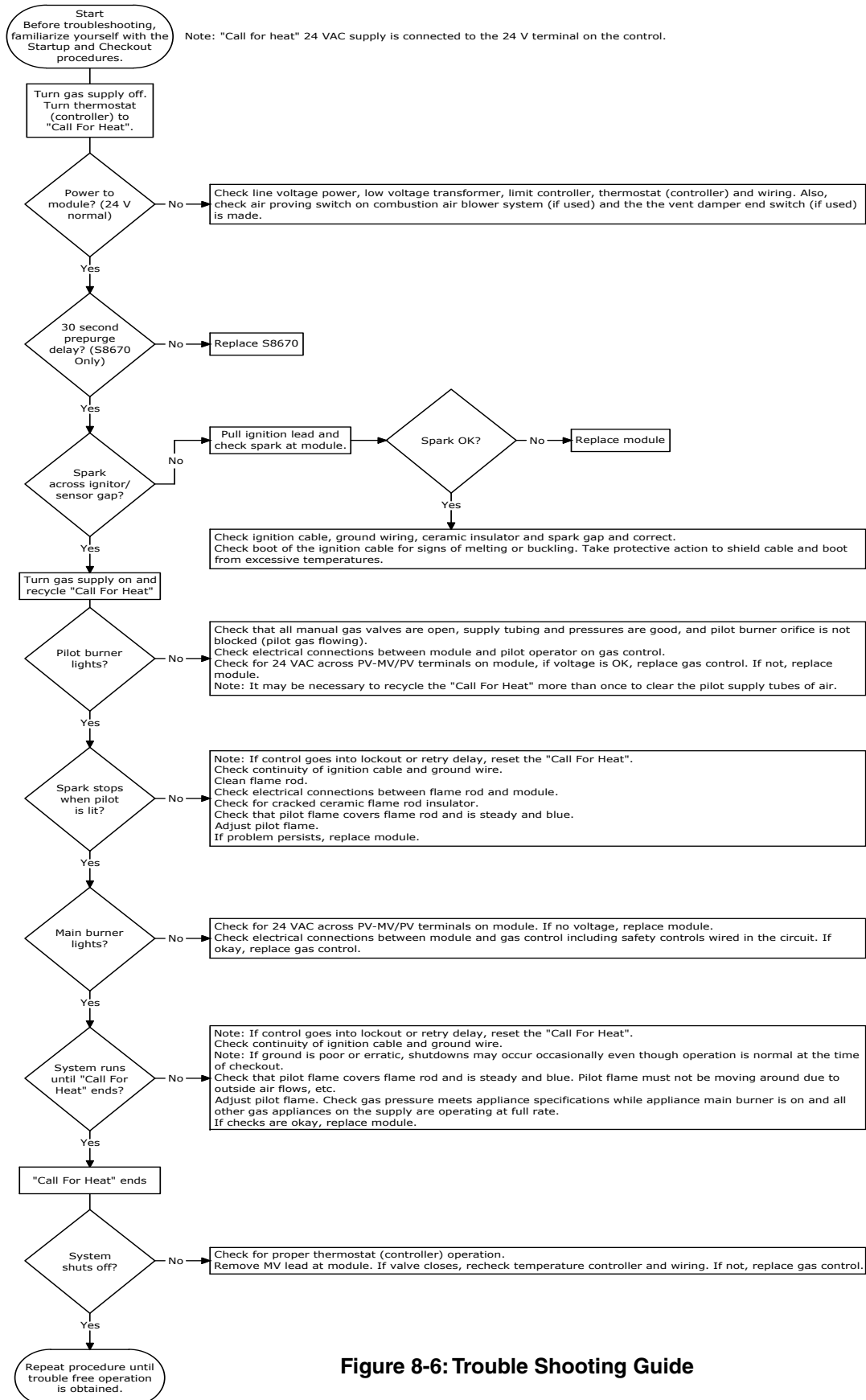

Figure 8-6: Trouble Shooting Guide

9 Service Parts

For service or repairs to boiler, call your heating contractor. When seeking information on boiler, provide Boiler Model Number and Serial Number as shown on Rating Label.

Boiler Model Number	Boiler Serial Number	Installation Date
Heating Contractor		Phone Number
Address		

All Series 8HE Service Parts may be obtained through your local Burnham Commercial Wholesale distributor. Should you require assistance in locating a Burnham Commercial Distributor in your area, or have questions regarding the availability of Burnham Commercial products or repair parts, please contact Burnham Commercial Customer Service at: 888-791-3790 or Fax (717) 293-5803.

9 Service Parts *(continued)*

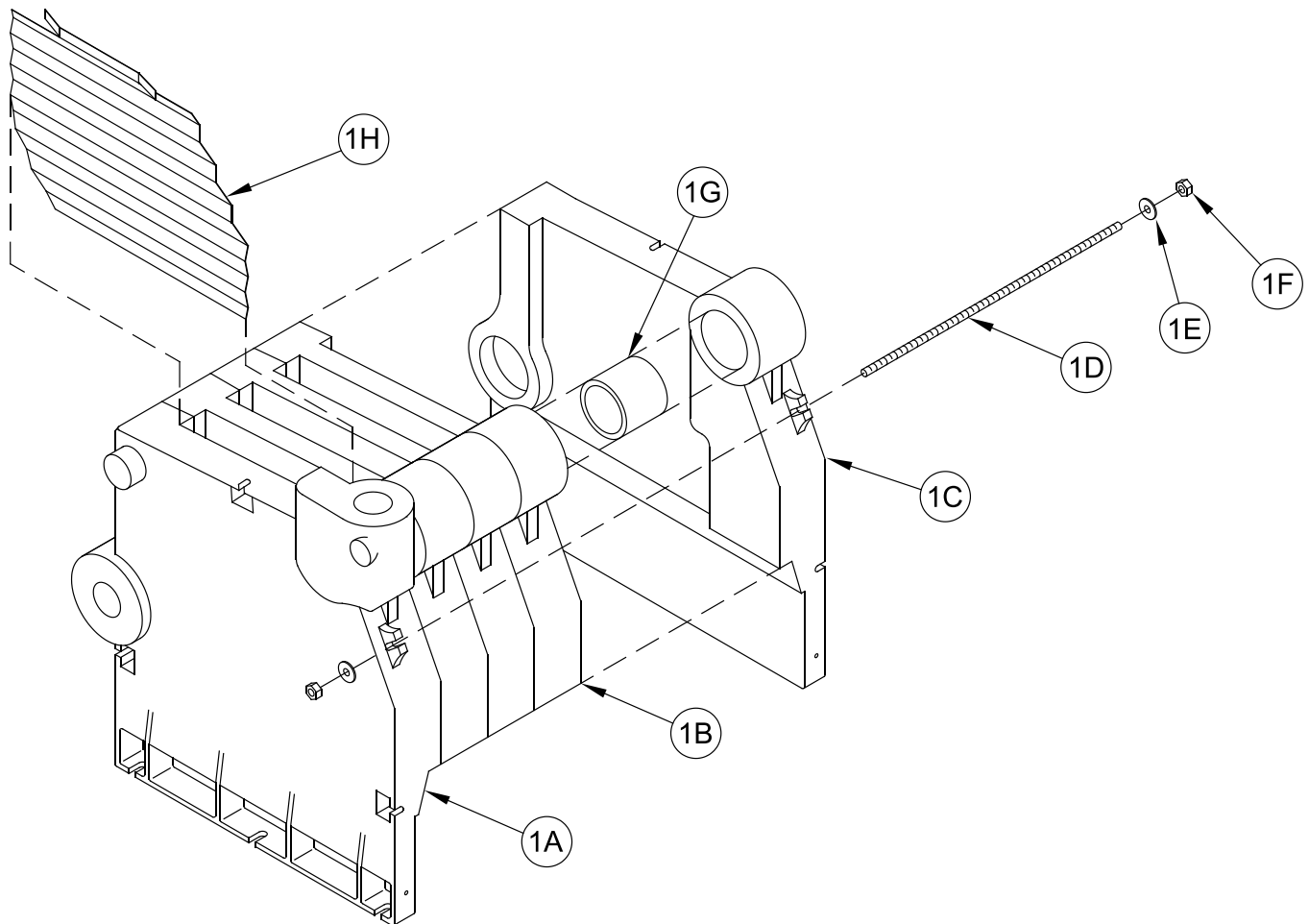

Item No.	Description	Part No.	Quantity	
			805HE	806HE
1. Heat Exchanger Assembly				
1	Complete (Less Flue Baffles)	6171605	1	---
		6171606	---	1
1A	Left End Section	N/A*	1	1
1B	Intermediate Section	N/A*	3	4
1C	Right End Section	N/A*	1	1
1D	Tie Rod	80861032	1	---
		80861033	---	1
1E	Washer, Flat, USS, 3/8 in.	**	4	4
1F	Hex Nut, 3/8 in. -16 Heavy	**	4	4
1G	Push Nipple, 3 in.	N/A*	8	10
1H	Flue Baffle	7111623	4	5

*N/A - Not available as individual item.

** Item to be sourced locally.

9 Service Parts *(continued)*

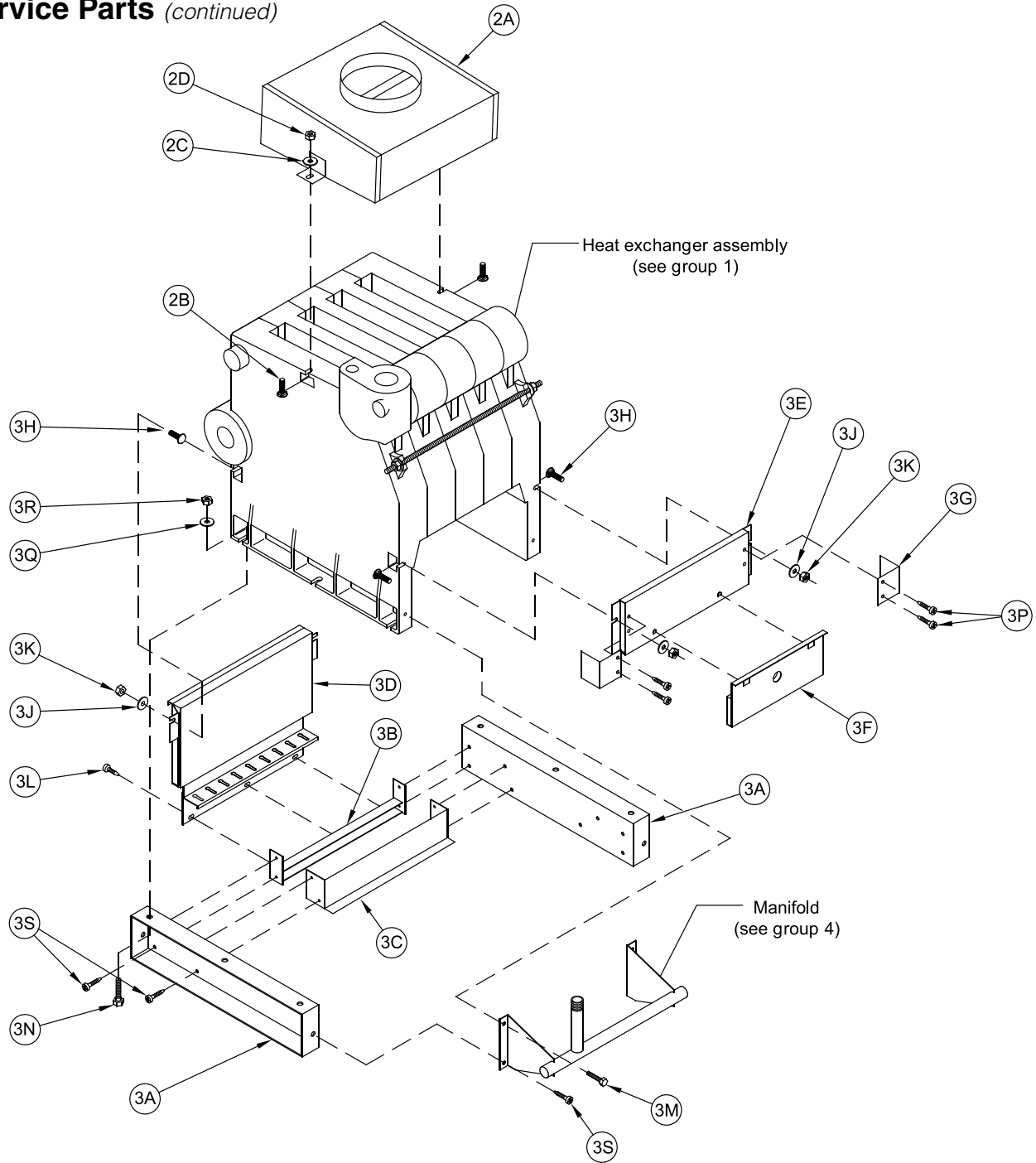

Item No.	Description	Part No.	Quantity	
			805HE	806HE
2. Canopy				
2A	Canopy	111770-01	1	---
		111770-02	---	1
--	Canpoy Seal, Ceramic Fiber Blanket	102741-01	6 ft.	6 ft.
2B	Bolt, Carriage, ¼ - 20 x 1 in.	**	2	2
2C	Washer, ¼ in. Flat	**	2	2
2D	Nut, ¼ in. - 20	**	2	2

** Item to be sourced locally.

9 Service Parts *(continued)*

Item No.	Description	Part No.	Quantity	
			805HE	806HE
3. Base Assembly				
3A	Base End Panel	7181601	2	2
3B	Base Channel Assembly	61816052	1	---
		61816062	---	1
3C	Burner Air Baffle/Diverter	111756-01	1	---
		111756-02	---	1
3D	Base Rear Panel Assembly	111909-05	1	---
		111909-06	---	1
3E	Base Front Panel Assembly	111912-05	1	---
		111912-06	---	1
3F	Burner Access Panel Assembly	111914-05	1	---
		111914-06	---	1
3G	Jacket Attachment Bracket	7041601	4	4
3H	Bolt, Carriage, ¼ - 20 x 1¼ in.	**	4	4
3J	Washer, ¼ in. Flat	**	4	4
3K	Nut, ¼ - 20	**	4	4
3L	Screw, Self Tapping, ¼ - 20 x ½ in.	**	3	4
3M	Screw, Cap, Hex Head, 5/16 in. - 18 x ¾ in.	**	2	2
3N	Screw, Cap, Hex Head, 5/16 - 18 x 1¼ in.	**	6	6
3P	Screw, Sheet Metal, #8 x ½ in.	**	8	8
3Q	Washer, 3/8 in. Flat	**	6	6
3R	Nut, 5/16 in.	**	6	6
3S	Screw, Self Tapping, ¼ - 20 x ¾ in.	**	10	10

** Item to be sourced locally.

9 Service Parts *(continued)*

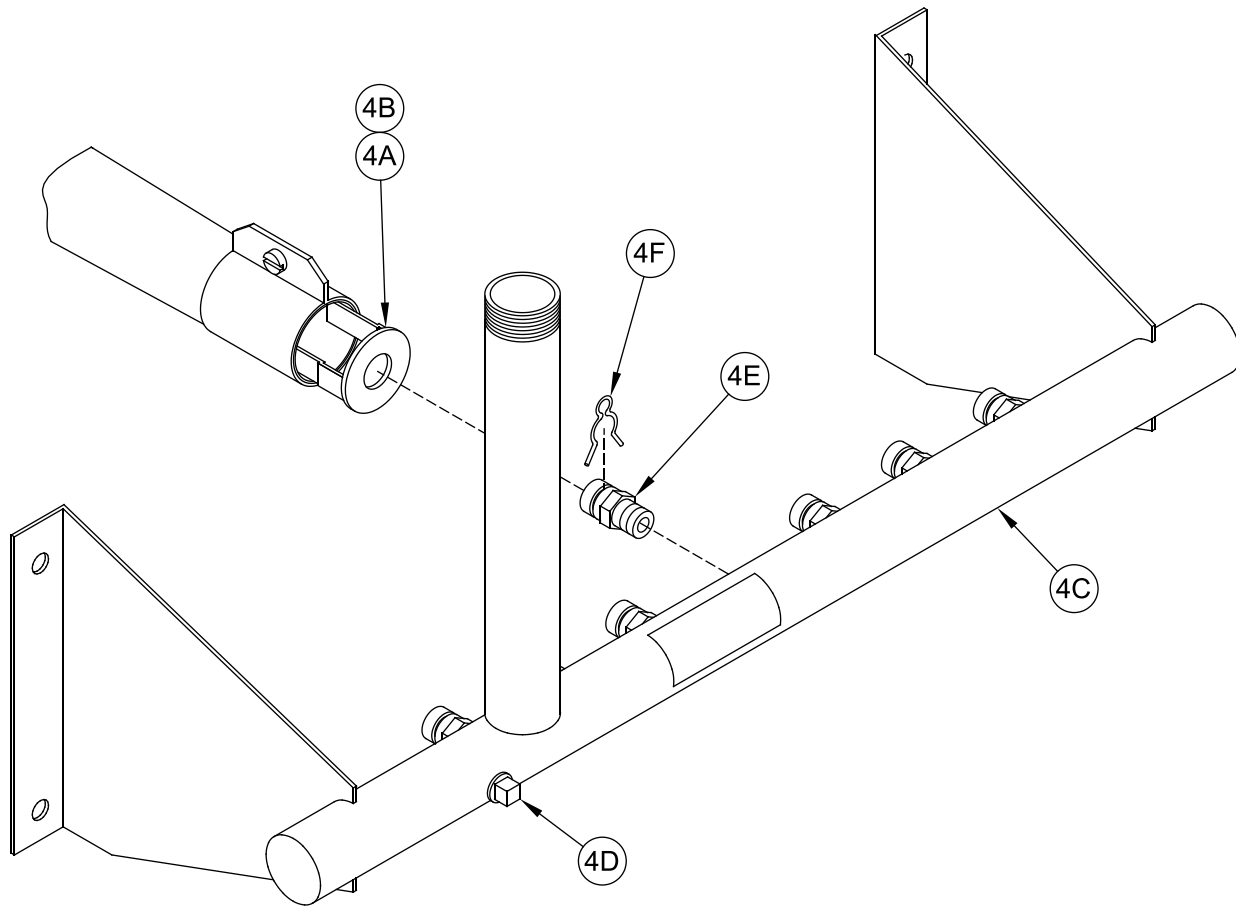

Item No.	Description	Part No.	Quantity	
			805HE	806HE
4. Manifold and Main Burners				
4A	Main Burner	8231602	8	10
4B	Main burner with Pilot Bracket	8231604	1	1
4C	Manifold	82216051	1	---
		82216061	---	1
4D	Pipe Plug, 1/8 NPT (Included with 4C)	---	1	1
4E	Main Burner Orifice, #41 (Natural Gas Only) *	822627	9	11
4F	Hitch Pin Clip	822604	9	11

* Main burner orifice sizes shown for normal altitude (0-2,000 feet). For High Altitude consult factory.

9 Service Parts *(continued)*

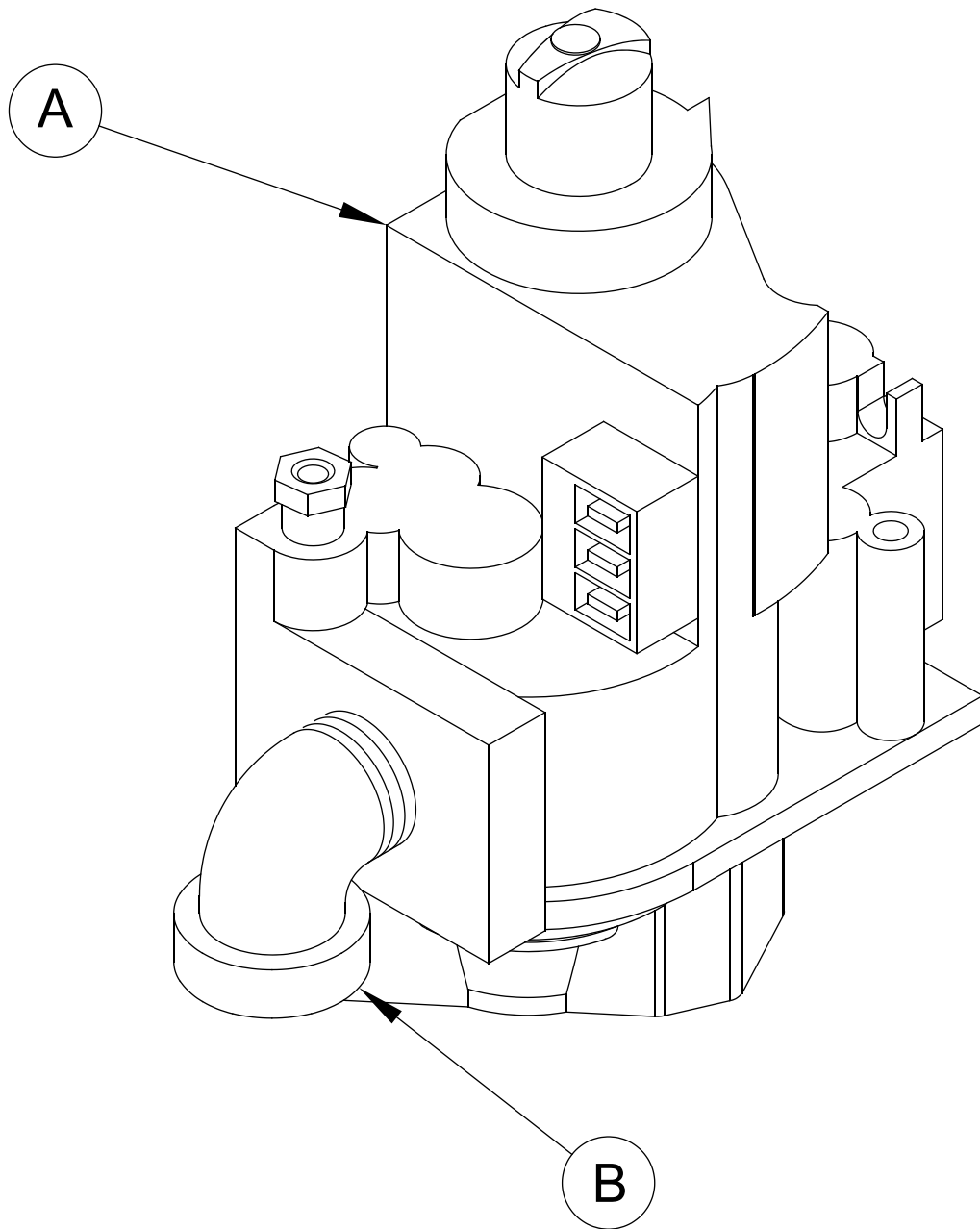

Item No.	Description	Part No.	Size	Quantity
5-1 Gas Train				
A	Gas Valve, Resideo VR8304P4496, Natural Gas, 3/4 in. NPT	81660283	805HE + 806HE	1
B	Reducing Street Elbow, 1 in. x 3/4 in. x 90°	**	805HE + 806HE	1

** Item to be sourced locally.

9 Service Parts *(continued)*

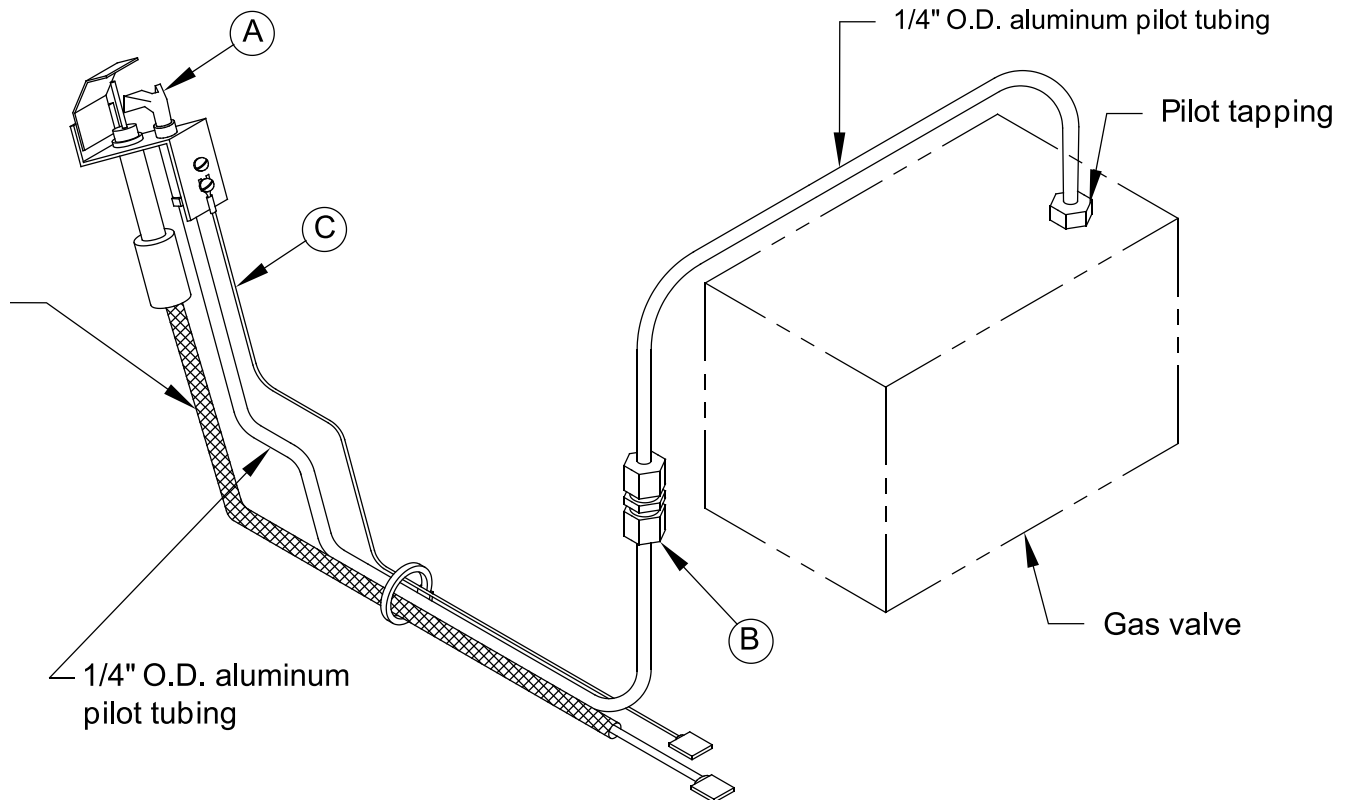

Item No.	Description	Part No.	Size	Quantity
5-2 Pilot Assembly and Piping				
A	Pilot Burner, Honeywell Q3481B1206, Natural Gas	103704-01	805HE + 806HE	1
B	Brass Compression Union, 1/4 in. OD Tube	8236008		1
C	Ground Wire	6136054		1

9 Service Parts *(continued)*

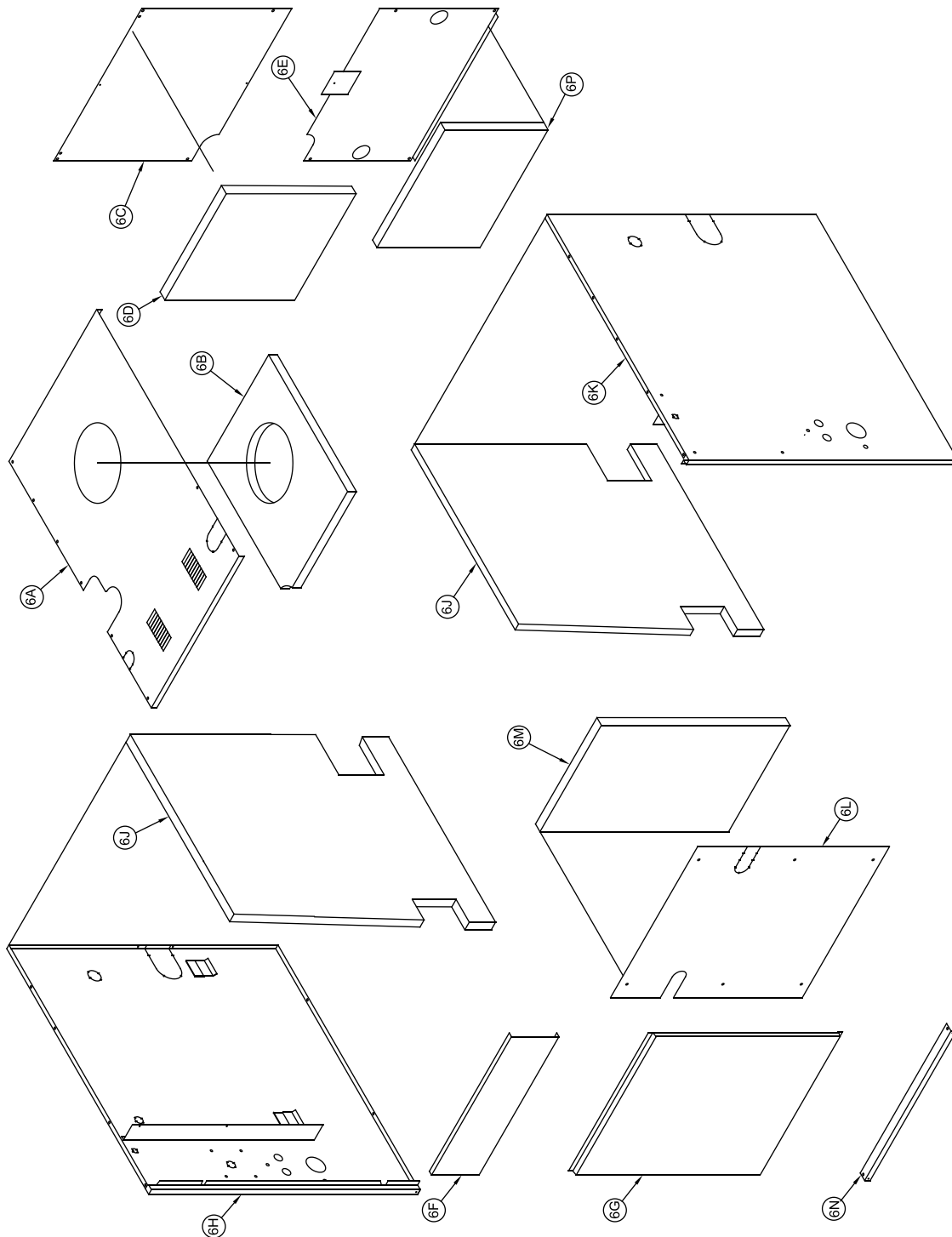

9 Service Parts *(continued)*

Item No.	Description	Part No.	Quantity	
			805HE	806HE
6. Jacket				
6	Complete	111907-05	1	---
		111907-06	---	1
6A	Jacket Top Panel	704160531	1	---
		70416063	---	1
6B	Jacket Top Panel Insulation	111812-01	1	---
		111812-02	---	1
6C	Jacket Upper Rear Panel	70416056	1	---
		70416066	---	1
6D	Jacket Upper Rear Panel Insulation	111816-01	1	---
		111816-02	---	1
6E	Jacket Lower Rear Panel	60416056	1	---
		60416066	---	1
6F	Jacket Upper Front Panel	70416051	1	---
		70416061	---	1
6G	Jacket Front Removable Panel	7041605	1	---
		7041606	---	1
6H	Jacket Left Side Panel	6041601	1	1
6J	Jacket Left and Right Side Panel Insulation Pieces	111814-01	2	2
6K	Jacket Right Side Panel	6041602	1	1
6L	Jacket Vestibule Panel	111784-01	1	---
		111784-02	---	1
6M	Jacket Vestibule Panel Insulation Piece	111811-01	1	---
		111811-02	---	1
6N	Jacket Lower Front Tie Bar	70416052	1	---
		70416062	---	1
6P	Jacket Lower Rear Panel Insulation	111817-01	1	---
		111817-02	---	1

9 Service Parts *(continued)*

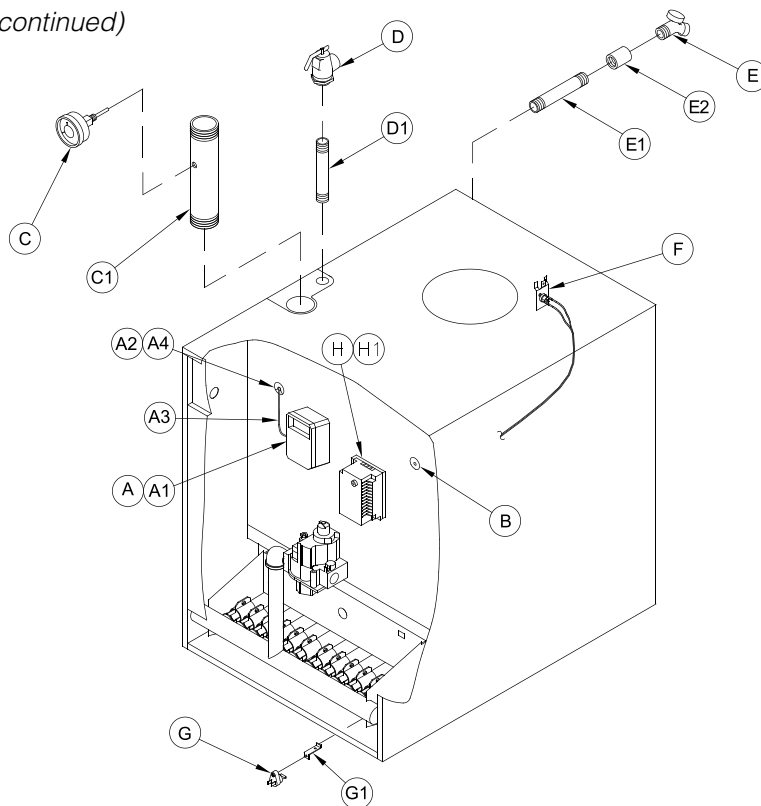

Item No.	Description	Part No.	Quantity	
			805HE	806HE
7. Trim and Miscellaneous Controls				
A	Hydrostat 3200 with Sensor	104873-01	1	1
A1	Remote Mount Bracket Assembly	104877-01	1	1
A2	Electrowell, Hydrostat 3200	105203-01	1	1
A3	Replacement 12 in. Sensor	105944-01	1	1
A4	Spring Clip	102422-01	1	1
B	Immersion Well, 3/4 in. NPT x 3 in. Insul. Depth	80160452	1	1
C	Temperature - Pressure Gauge	100282-01	1	1
C1	Nipple, 2 NPT x 10 in. w/Gauge Tapping	8061601	1	1
D	Pressure Relief Valve, 3/4 NPT, 50 psi	103837-01	1	1
D1	Nipple, 3/4 NPT x 3 1/2 in.	**	1	1
E	Drain Valve, 3/4 NPT, Conbraco 35-302-03	806603061	1	1
E1	Nipple, 3/4 NPT x 3 1/2 in.	**	1	1
E2	Coupling, 3/4 NPT	**	1	1
F	Blocked Vent Switch Replacement Assembly	6016058	1	1
G	Flame Roll-out Switch	80160044	1	1
G1	Flame Roll-out Switch Mounting Bracket	7181612	1	1
H	Ignition Module, Honeywell S8610M3009	100958-01	1	1
H1	Module Support Bracket	7016001	1	1
J	Hydrostat 3200, Resideo S8610M, FRS, and BVS Wiring Harness (not depicted)	111746-01	1	1
K	Gas Valve to ignition Module Wiring Harness (not depicted)	104871-01	1	1
L	Green Ground Wire (not depicted)	6136054	1	1

** Item to be sourced locally.

9 Service Parts *(continued)*

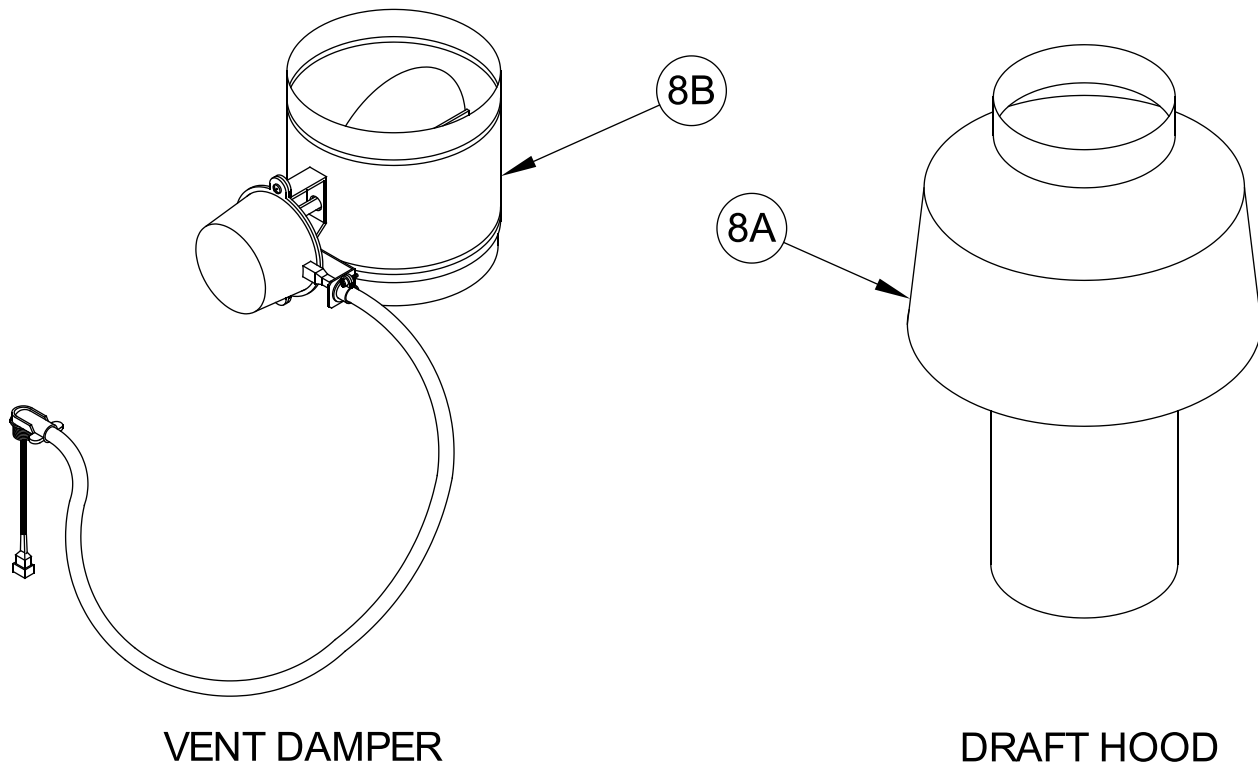

Item No.	Description	Part No.	Quantity	
			805HE	806HE
8. Draft Hood and Automatic Vent Damper				
8A	Draft Hood	109434-01	1	
8A	Drafthood	8111604		1
8B	Automatic Vent Damper, 7 in.			
	Field Controls GVD-7PL	8116324	1	1

Limited Warranty

For Commercial Grade Boilers

Using Cast Iron, Carbon Steel,
or Stainless Steel Heat Exchangers
and Parts/Accessories

Subject to the terms and conditions set forth below, Burnham Commercial, Lancaster, Pennsylvania hereby extends the following limited warranties to the original owner of a commercial grade water or steam boiler or Burnham Commercial supplied parts and/or accessories manufactured and shipped on or after October 1, 2009:

ONE YEAR LIMITED WARRANTY ON COMMERCIAL GRADE BOILERS AND PARTS / ACCESSORIES SUPPLIED BY BURNHAM COMMERCIAL.

Burnham Commercial warrants to the original owner that its commercial grade water and steam boilers and parts/accessories comply at the time of manufacture with recognized hydronic industry standards and requirements then in effect and will be free of defects in material and workmanship under normal usage for a period of one year from the date of original installation. If any part of a commercial grade boiler or any part or accessory provided by Burnham Commercial is found to be defective in material or workmanship during this one year period, Burnham Commercial will, at its option, repair or replace the defective part (not including labor).

HEAT EXCHANGER WARRANTIES

Burnham Commercial warrants to the original owner that the heat exchanger of its commercial grade boilers will remain free from defects in material and workmanship under normal usage for the time period specified in the chart below to the original owner at the original place of installation. If a claim is made under this warranty during the "No Charge" period from the date of original installation, Burnham Commercial will, at its option, repair or replace the heat exchanger (not including labor). If a claim is made under this warranty after the expiration of the "No Charge" period from the date of original installation, Burnham Commercial will, at its option and upon payment of the pro-rated service charge set forth below, repair or replace the heat exchanger. The service charge applicable to a heat exchanger warranty claim is based upon the number of years the heat exchanger has been in service and will be determined as a percentage of the retail price of the heat exchanger model involved at the time the warranty claim is made as follows:

Years in Service	Service Charge as a % of Retail Price									
	1	2	3	4	5	6	7	8	9	10+
Cast Iron	No Charge									100
Carbon Steel	No Charge	100								
Stainless Steel	No Charge				20	40	60	80	100	

NOTE: If the heat exchanger involved is no longer available due to product obsolescence or redesign, the value used to establish the retail price will be the published price as set forth in Burnham Commercial Repair Parts Pricing where the heat exchanger last appeared or the current retail price of the then nearest equivalent heat exchanger, whichever is greater.

ADDITIONAL TERMS AND CONDITIONS

- Applicability: The limited warranties set forth above are extended only to the original owner at the original place of installation within the United States and Canada. These warranties are applicable only to boilers, parts, or accessories designated as commercial grade by Burnham Commercial and installed and used exclusively for purposes of commercial space heating or domestic hot water generation through a heat exchanger (or a combination for such purposes) and do not apply to residential grade products or industrial uses.
- Components Manufactured by Others: Upon expiration of the one year limited warranty on commercial grade boilers, all boiler components other than heat exchangers manufactured by others but furnished by Burnham Commercial (such as oil burner, circulator and controls) will be subject only to the manufacturer's warranty, if any.
- Proper Installation: The warranties extended by Burnham Commercial are conditioned upon the installation of the commercial grade boiler, parts, and accessories in strict compliance with Burnham Commercial installation instructions. Burnham Commercial specifically disclaims liability of any kind caused by or relating to improper installation.
- Proper Use and Maintenance: The warranties extended by Burnham Commercial are conditioned upon the use of the commercial grade boiler, parts, and accessories for its intended purposes and its maintenance accordance with Burnham Commercial recommendations and hydronics industry standards. For proper installation, use, and maintenance, see all applicable sections of the Installation and Operating, and Service Instructions Manual furnished with the unit.
- This warranty does not cover the following:
 - Expenses for removal or reinstallation. The owner will be responsible for the cost of removing and reinstalling the alleged defective part or its replacement and all labor and material connected therewith, and transportation to and from Burnham Commercial.
 - Components that are part of the heating system but were not furnished by Burnham Commercial as part of the commercial boiler.
 - Improper burner adjustment, control settings, care or maintenance.
 - This warranty cannot be considered as a guarantee of workmanship of an installer connected with the installation of the Burnham Commercial boiler, or as imposing on Burnham Commercial liability of any nature for unsatisfactory performance as a result of faulty workmanship in the installation, which liability is expressly disclaimed.

- Boilers, parts, or accessories installed outside the 48 contiguous United States, the State of Alaska and Canada.
 - Damage to the boiler and/or property due to installation or operation of the boiler that is not in accordance with the boiler installation and operating instruction manual.
 - Any damage or failure of the boiler resulting from hard water, scale buildup or corrosion the heat exchanger.
 - Any damage caused by improper fuels, fuel additives or contaminated combustion air that may cause fireside corrosion and/or clogging of the burner or heat exchanger.
 - Any damage resulting from combustion air contaminated with particulate which cause clogging of the burner or combustion chamber including but not limited to sheetrock or plasterboard particles, dirt, and dust particulate.
 - Any damage, defects or malfunctions resulting from improper operation, maintenance, misuse, abuse, accident, negligence including but not limited to operation with insufficient water flow, improper water level, improper water chemistry, or damage from freezing.
 - Any damage caused by water side clogging due to dirty systems or corrosion products from the system.
 - Any damage resulting from natural disaster.
 - Damage or malfunction due to the lack of required maintenance outlined in the Installation and Operating Manuals furnished with the unit.
6. Exclusive Remedy: Burnham Commercial obligation for any breach of these warranties is limited to the repair or replacement of its parts (not including labor) in accordance with the terms and conditions of these warranties.
7. Limitation of Damages: Under no circumstances shall Burnham Commercial be liable for incidental, indirect, special or consequential damages of any kind whatsoever under these warranties, including, but not limited to, injury or damage to persons or property and damages for loss of use, inconvenience or loss of time. Burnham Commercial liability under these warranties shall under no circumstances exceed the purchase price paid by the owner for the commercial grade boiler involved. Some states do not allow the exclusion or limitation of incidental or consequential damages, so the above limitation or exclusion may not apply to you.
8. Limitation of Warranties: These warranties set forth the entire obligation of Burnham Commercial with respect to any defect in a commercial grade boiler, parts, or accessories and Burnham Commercial shall have no express obligations, responsibilities or liabilities of any kind whatsoever other than those set forth herein. These warranties are given in lieu of all other express warranties.

ALL APPLICABLE IMPLIED WARRANTIES, IF ANY, INCLUDING ANY WARRANTY OF MERCHANTABILITY OR FITNESS FOR A PARTICULAR PURPOSE ARE EXPRESSLY LIMITED IN DURATION TO A PERIOD OF ONE YEAR EXCEPT THAT IMPLIED WARRANTIES, IF ANY, APPLICABLE TO THE HEAT EXCHANGER IN A COMMERCIAL GRADE BOILER SHALL EXTEND TO THE ORIGINAL OWNER FOR THE TIME SPECIFIED IN THE HEAT EXCHANGER SECTION SHOWN ABOVE AT THE ORIGINAL PLACE OF INSTALLATION. SOME STATES DO NOT ALLOW LIMITATION ON HOW LONG AN IMPLIED WARRANTY LASTS, SO THE ABOVE LIMITATION MAY NOT APPLY TO YOU.

PROCEDURE FOR OBTAINING WARRANTY SERVICE

In order to assure prompt warranty service, the owner is requested to complete and mail the Warranty Card provided with the product or register product online at www.burnhamcommercialcastiron.com within ten days after the installation of the boiler, although failure to comply with this request will not void the owner's rights under these warranties. Upon discovery of a condition believed to be related to a defect in material or workmanship covered by these warranties, the owner should notify the installer, who will in turn notify the distributor. If this action is not possible or does not produce a prompt response, the owner should write to Burnham Commercial, P.O. Box 3939, Lancaster, PA 17604, giving full particulars in support of the claim. The owner is required to make available for inspection by Burnham Commercial or its representative the parts claimed to be defective and, if requested by Burnham Commercial to ship these parts prepaid to Burnham Commercial at the above address for inspection or repair. In addition, the owner agrees to make all reasonable efforts to settle any disagreement arising in connection with a claim before resorting to legal remedies in the courts.

THIS WARRANTY GIVES YOU SPECIFIC LEGAL RIGHTS AND YOU MAY ALSO HAVE OTHER RIGHTS WHICH VARY FROM STATE TO STATE.



Burnham Commercial Boilers
P.O. Box 3939
Lancaster, PA 17604
1-888-791-3790
www.burnhamcommercial.com

From: [Justin Genga](#)
To: [Devin Marra](#)
Subject: Camus DMNH Boilers - Annual Maintenance
Date: Tuesday, June 6, 2023 4:53:01 PM
Attachments: [Thermal_b98ccbb-a1c5-4374-aeda-25a032ecd06b.png](#)
[DynaMaxHS IOM UL.pdf](#)

Good Afternoon Devin,

As discussed last week, we are the only manufacturers rep in Connecticut for Camus Boilers. Please see the attached service and operation manual. On top of this please see the below for recommended parts to be changed yearly. Please let me know when the bid comes out so that we can submit pricing for the service. We get these parts at cost from the manufacturer and also stock them in our warehouse in CT.

Parts to be replaced yearly:

- Igniter
- Flame Sensor
- Sensor Gasket
- Igniter Gasket
- Blocked Flue Switch
- Air Proving Switch w/ Hoses
- Stack/Flue Sensor
- Inlet & Outlet Temperature Sensor/Lead Lag Sensor

Please let me know if you have any questions.

Thanks,
Justin

Justin Genga | Aftermarket Sales
Justin.Genga@blakethermal.com
P: 800-353-1100 x2018 | M: 860-978-4701
www.blakethermal.com



4 New Park Road | East Windsor, CT 06088
Customer Focused | Opportunity is Earned | Solutions Provider
Can-Do Attitude | Driven to Win | Confident but Humble

CREST[®]

CONDENSING BOILER

Service Manual w/CON•X•US Interface

Models: 751 - 6001
Series: 100 - 101 & 110 - 111



⚠ WARNING

This manual must only be used by a qualified heating installer / service technician. Read all instructions, including this manual and the Crest Installation and Operation Manual, before installing. Perform steps in the order given. Failure to comply could result in severe personal injury, death, or substantial property damage.

Save this manual for future reference.

Contents

CONTENTS	2	Night Setback Screen	25
Hazard Definitions.....	2	Pump Screen	26-28
PLEASE READ BEFORE PROCEEDING	3	Cascade Screens	29-31
Handling Ceramic Fiber Materials.....	3	Service Screen.....	32-33
When servicing boiler	4	Graph Screens.....	34
Boiler operation.....	4	History Screens.....	35
Boiler water.....	4	2. MAINTENANCE	
Freeze protection fluids	4	Maintenance and Annual Startup.....	36-41
WHAT IS IN THIS MANUAL	5	3. TROUBLESHOOTING	
1. SERVICE		Before Troubleshooting.....	42
Boiler Piping.....	6	Check Control Module Fuses	42
SMART TOUCH w/CON•X•US Interface	7	Table 3A - Troubleshooting Chart - No Display.....	43
General Operation	8	Checking Temperature Sensors	44
Control Inputs	9	Table 3F - Troubleshooting Chart - Noisy System	45
Control Outputs.....	10	Table 3G - Troubleshooting Chart - Fault Messages .	46-56
Table 1A - Sequence of Operation	11	Combustion Analysis Procedure	57
Initial Setup Screen.....	12	Table 3H - Flue Products.....	57
Viewable and Changeable Control Parameters.....	13	Table 3I - Troubleshooting Chart - Combustion Levels .	58
Set Point Screen.....	13-15	Gas Valve Adjustment Procedure.....	59
Outdoor Reset Screen.....	16-17	Revision Notes	Back Cover
Ramp Delay Screen	18-19		
BMS Screen.....	20-22		
Advanced Setup Screen.....	23-24		

Hazard definitions

The following defined terms are used throughout this manual to bring attention to the presence of hazards of various risk levels or to important information concerning the life of the product.

 **DANGER** DANGER indicates an imminently hazardous situation which, if not avoided, will result in death or serious injury.

 **WARNING** WARNING indicates a potentially hazardous situation which, if not avoided, could result in death or serious injury.

 **CAUTION** CAUTION indicates a potentially hazardous situation which, if not avoided, may result in minor or moderate injury.

CAUTION CAUTION used without the safety alert symbol indicates a potentially hazardous situation which, if not avoided, may result in property damage.

 **NOTICE** NOTICE indicates special instructions on installation, operation, or maintenance that are important but not related to personal injury or property damage.

Please read before proceeding

WARNING

Installer – Read all instructions, including this manual and the Crest Installation and Operation Manual, before installing. Perform steps in the order given.

User – This manual is for use only by a qualified heating installer/service technician. Refer to the Crest User's Information Manual for your reference.

Have this boiler serviced/inspected by a qualified service technician at least annually.

Failure to comply with the above could result in severe personal injury, death or substantial property damage.

NOTICE

When calling or writing about the boiler – Please have the boiler model and serial number from the boiler rating plate.

Consider piping and installation when determining boiler location (see the Crest Installation and Operation Manual).

Any claims for damage or shortage in shipment must be filed immediately against the transportation company by the consignee.

Handling ceramic fiber materials

REMOVAL OF COMBUSTION CHAMBER LINING

WARNING

The combustion chamber insulation in this appliance contains ceramic fiber material. Ceramic fibers can be converted to cristobalite in very high temperature applications. The International Agency for Research on Cancer (IARC) has concluded, "Crystalline silica in the form of quartz or cristobalite from occupational sources is carcinogenic to humans (Group 1)." Normal operating temperatures in this appliance are below the level to convert ceramic fibers to cristobalite. Abnormal operating conditions would have to be created to convert the ceramic fibers in this appliance to cristobalite.

The ceramic fiber material used in this appliance is an irritant; when handling or replacing the ceramic materials it is advisable that the installer follow these safety guidelines.

- Avoid breathing dust and contact with skin and eyes.
 - Use NIOSH certified dust respirator (N95). This type of respirator is based on the OSHA requirements for cristobalite at the time this document was written. Other types of respirators may be needed depending on the job site conditions. Current NIOSH recommendations can be found on the NIOSH website at <http://www.cdc.gov/niosh/homepage.html>. NIOSH approved respirators, manufacturers, and phone numbers are also listed on this website.
 - Wear long-sleeved, loose fitting clothing, gloves, and eye protection.
- Apply enough water to the combustion chamber lining to prevent airborne dust.
- Remove the combustion chamber lining from the appliance and place it in a plastic bag for disposal.
- Wash potentially contaminated clothes separately from other clothing. Rinse clothes washer thoroughly.

NIOSH stated First Aid.

- Eye: Irrigate immediately.
- Breathing: Fresh air.

Please read before proceeding

When servicing boiler –

- To avoid electric shock, disconnect electrical supply before performing maintenance.
- To avoid severe burns, allow boiler to cool before performing maintenance.

Boiler operation –

- Do not block flow of combustion or ventilation air to the boiler.
- Should overheating occur or gas supply fail to shut off, do not turn off or disconnect electrical supply to circulator. Instead, shut off the gas supply at a location external to the appliance.
- Do not use this boiler if any part has been under water. The possible damage to a flooded appliance can be extensive and present numerous safety hazards. Any appliance that has been under water must be replaced.

Boiler water –

- Thoroughly flush the system (without boiler connected) to remove sediment. The high-efficiency heat exchanger can be damaged by build-up or corrosion due to sediment.
- Do not use petroleum-based cleaning or sealing compounds in the boiler system. Gaskets and seals in the system may be damaged. This can result in substantial property damage.
- Do not use “homemade cures” or “boiler patent medicines”. Serious damage to the boiler, personnel, and/or property may result.
- Continual fresh make-up water will reduce boiler life. Mineral buildup in the heat exchanger reduces heat transfer, overheats the stainless steel heat exchanger, and causes failure. Addition of oxygen carried in by makeup water can cause internal corrosion. Leaks in boiler piping must be repaired at once to prevent the introduction of makeup water.

Freeze protection fluids –

- NEVER use automotive antifreeze. Use only inhibited propylene glycol solutions which are specifically formulated for hydronic systems. Ethylene glycol is toxic and can attack gaskets and seals used in hydronic systems.

What is in this manual?

Service

Near boiler piping

- Typical system components

The Crest boiler display

- Display panel readout, buttons and their functions

Control module inputs

- Control module inputs and options

Control module outputs

- Control module outputs and options

General

- How the boiler operates
- How the control module operates
- Access modes -- user and installer
- Sequence of operation -- HW/space heating

Control panel menu access

- Accessing programming mode and locating menus
(See separate guide covering the PC interface.)

Control panel parameter access

- Accessing and changing parameters from the display panel

Quick start information -- parameter table

- An index of available adjustments and readouts, where to access them and where to find detailed information.

Crest boiler operation

- Initial Setup
- Set Points
- Outdoor Reset
- Ramp Delay
- BMS
- Advanced Setup
- SH Night Setback
- HW Night Setback
- Cascade
- Pumps
- Service Notification

Maintenance

- Service and maintenance schedules
- Address reported problems
- Inspect boiler area and boiler interior
- Clean condensate trap
- Check all piping for leaks
- Check air openings
- Flue vent system and air piping
- Check water system
- Check expansion tank
- Check boiler relief valve
- Inspect ignition electrode
- Check ignition ground wiring
- Check all boiler wiring
- Check control settings
- Perform start-up and checks
- Check burner flame
- Check flame signal
- Check flue gas temperature
- General maintenance
- Review with owner
- Cleaning boiler heat exchanger
- Oiled bearing circulators

Troubleshooting

- Troubleshooting table - No display
- Checking temperature sensors
- Sensor tables
- Troubleshooting table - Fault messages displayed on boiler interface
- Combustion analysis procedure
- Gas valve adjustment procedure

1 Service

Boiler piping

This piping reference is included to specify the *Boiler Piping* specific to the Crest boiler. This piping scheme is important for proper operation of the SMART TOUCH control. See the Crest Installation and Operation Manual for more detailed piping diagrams.

Single Boiler - Recommended - Primary / Secondary Piping with a Hot Water Generator

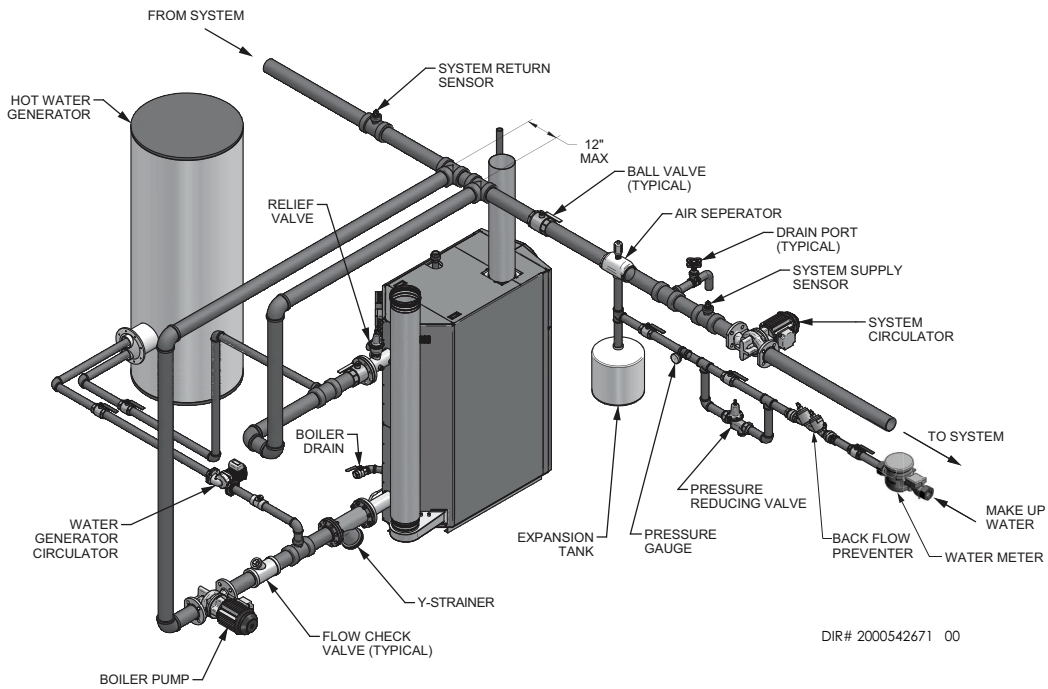

Single Boiler - Alternate - Full Flow System Piping

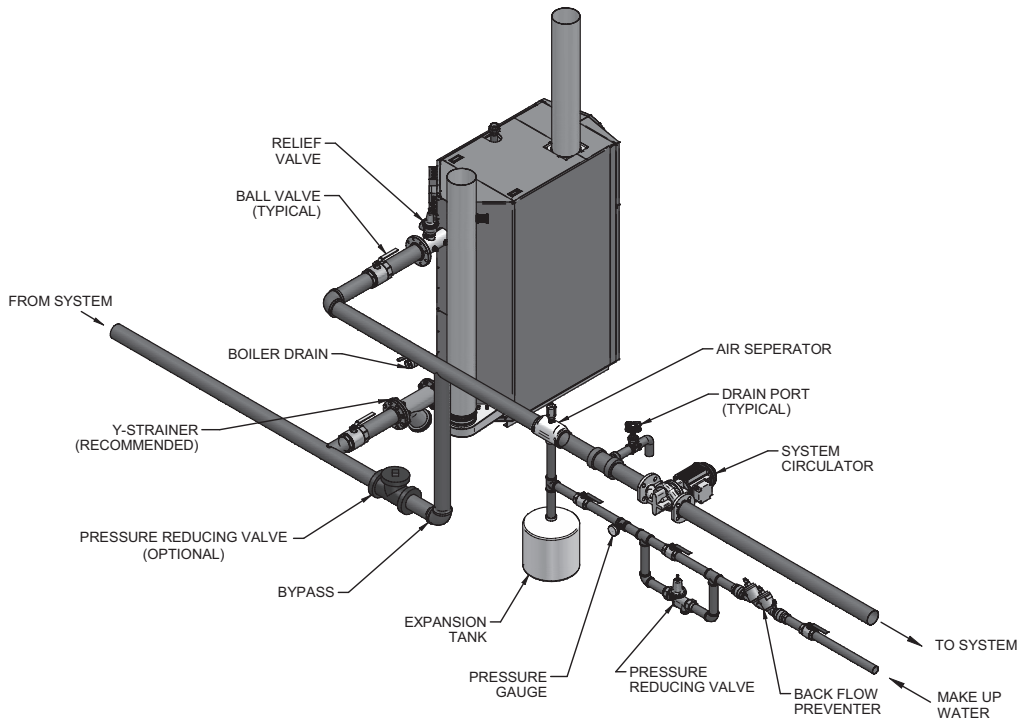

1 Service *(continued)*



w/Crest CON•X•US Interface (CCI)

The Home Screen displays the available basic system information divided into the following sections: Status, Demand, Modulation, Sensors, and Navigation.

Figure 1-1 Home Screen

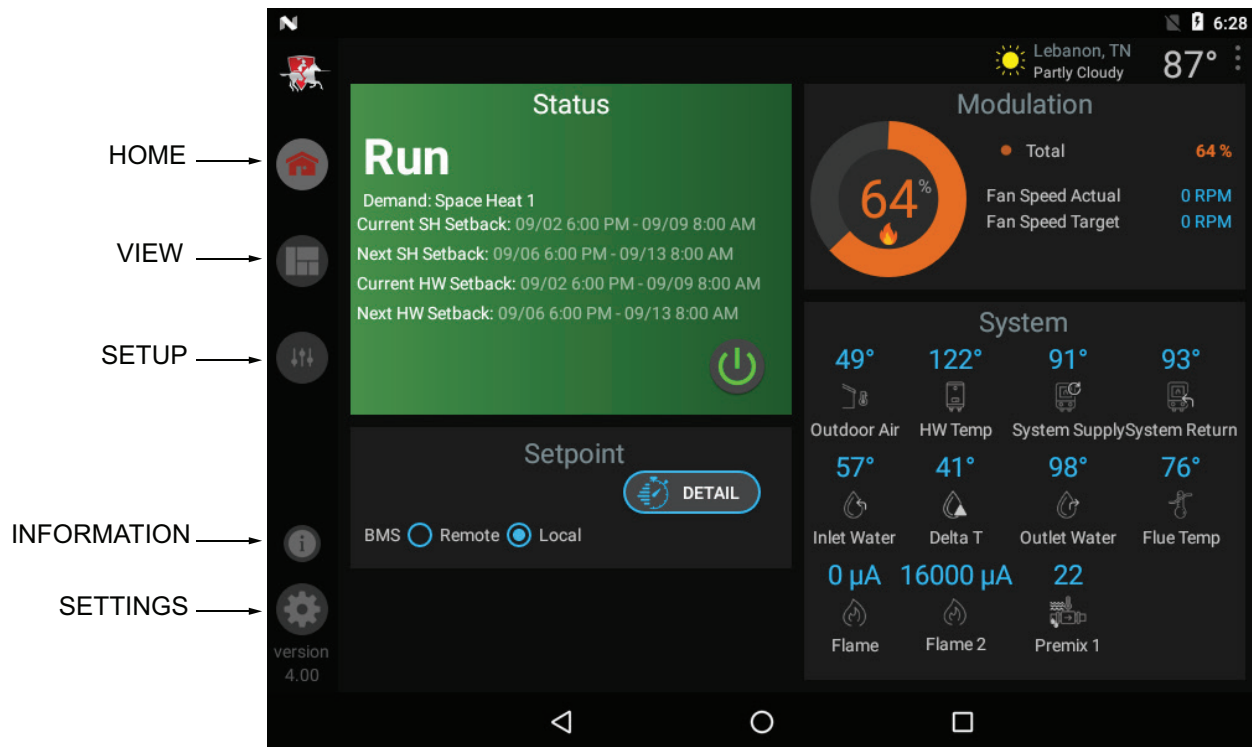

- The **Status** Section is located on the top left of the screen and displays how the unit is currently running (i.e. Off, Stand-by, Blocking, and Lockout) including: current driving demand, the next Hot Water Setback scheduled, the reason for any blocking or lockout, and a power button.
- The **Demand** Section is located on the bottom left of the screen and displays information about the targets and limits of the current demand being serviced.
- The **Modulation** Section is located on the top right of the screen and displays the target modulation of the unit. This section also includes target and actual fan speeds.
- The **Sensor** Section is located on the bottom right of the screen and displays both factory installed and field installed sensor including: Outdoor Air, Hot Water Temperature, System Supply, System Return, Inlet Water, Delta T, Outlet Water, Flue Temperature, and Flame Current.
- The **Navigation** Section is located down the left side of the screen. There are five (5) sections located below the Lochinvar icon: Home, View, Setup, Information (About), and Settings. The Home Section is the screen shown above. The View Section provides more detailed information including subsections for: History, Cascade, Graphing, and a complete list of current Sensor Values. The Setup Section has several screens to aid in setting up the appliance. The Setup Section includes screens for adjusting: Set Points, Pump Settings, Cascade, BMS, Ramp Delay, and Night Setback. The Information Section provides information about the hardware and software including the current software version of the interface, the version of the boiler control, and the CON-X-US device serial number. The Setting Section enables several interface setup features including: Time Setup, Temperature Unit Select, Loch'n Link, System Update, and WiFi Setup.

1 Service

General Operation

How the boiler operates

The Crest uses an advanced stainless steel heat exchanger and electronic control module that allows fully condensing operation. The blowers pull in air and push flue products out of the boiler through the heat exchanger and flue piping. The control module regulates blower speeds to control the boiler firing rate. The gas valves sense the amount of air flowing into the boiler and allow only the right amount of gas to flow.

How the control modules operate

The Crest boiler is equipped with a SMART TOUCH CON•X•US Interface. The control module receives inputs from boiler sensors and external devices. The control module activates and controls the blowers and gas valves to regulate heat input and switches the boiler, Hot Water Generator (HW), and system pumps on and off as needed. The user programs the control module to meet system needs by adjusting control parameters through the SMART TOUCH CON•X•US Interface. These parameters set operating temperatures and boiler operating modes.

Sequence of operation

Table 1A (page 11) shows control module normal sequences of operation for space heating and HW operation. The combined operation sequence is for a typical application, programmed to provide HW priority.

Access modes

User

The USER can set the SH set point, HW set point, turn the unit OFF and ON and set up WiFi.

Installer

Most parameters are available only to the INSTALLER, accessible only by entering the installer password (5309) when selecting the Setup Section.

Note: The password will timeout after an hour from entry.

1 Service *(continued)*

Control inputs

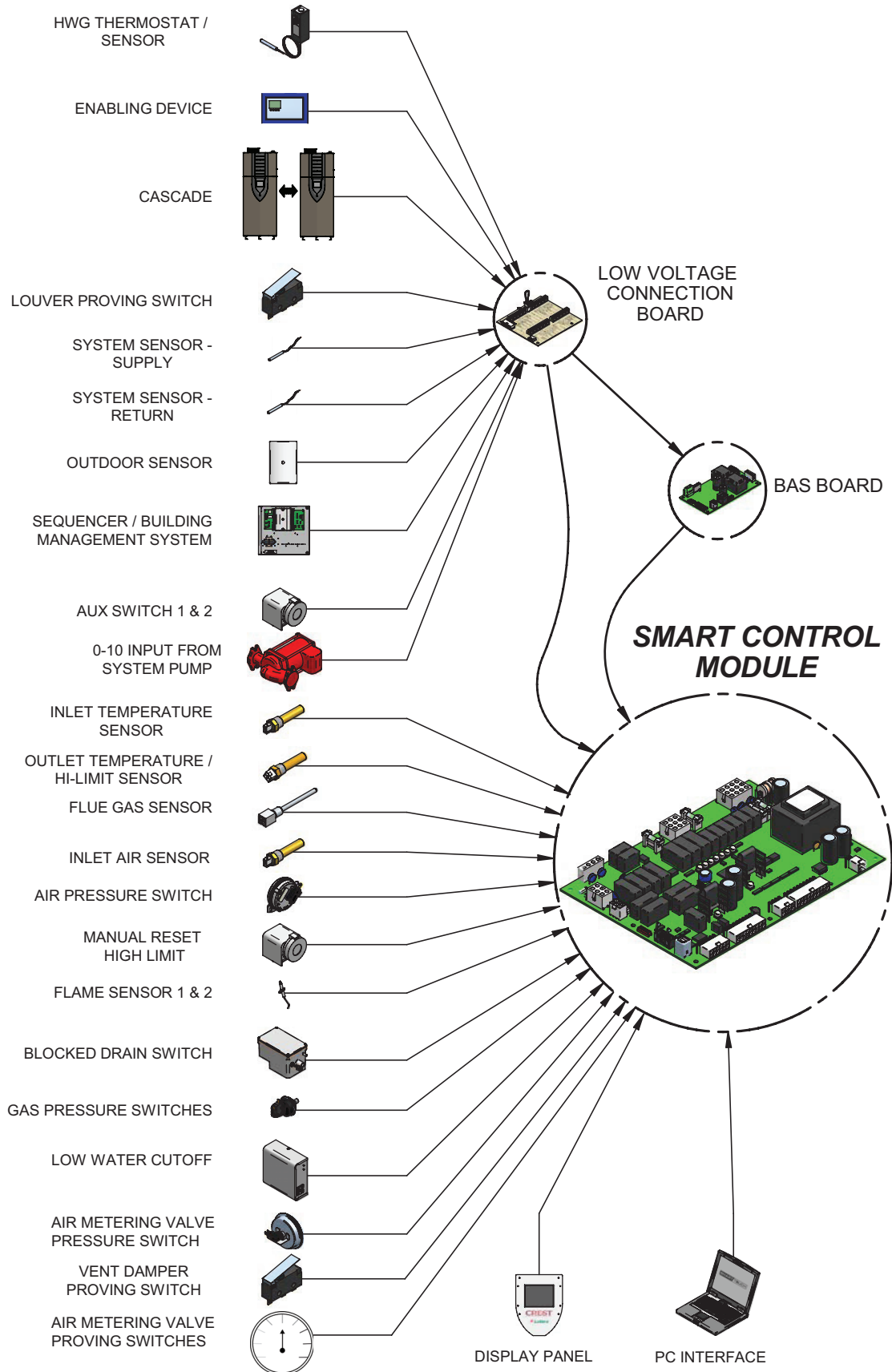

1 Service

Control outputs

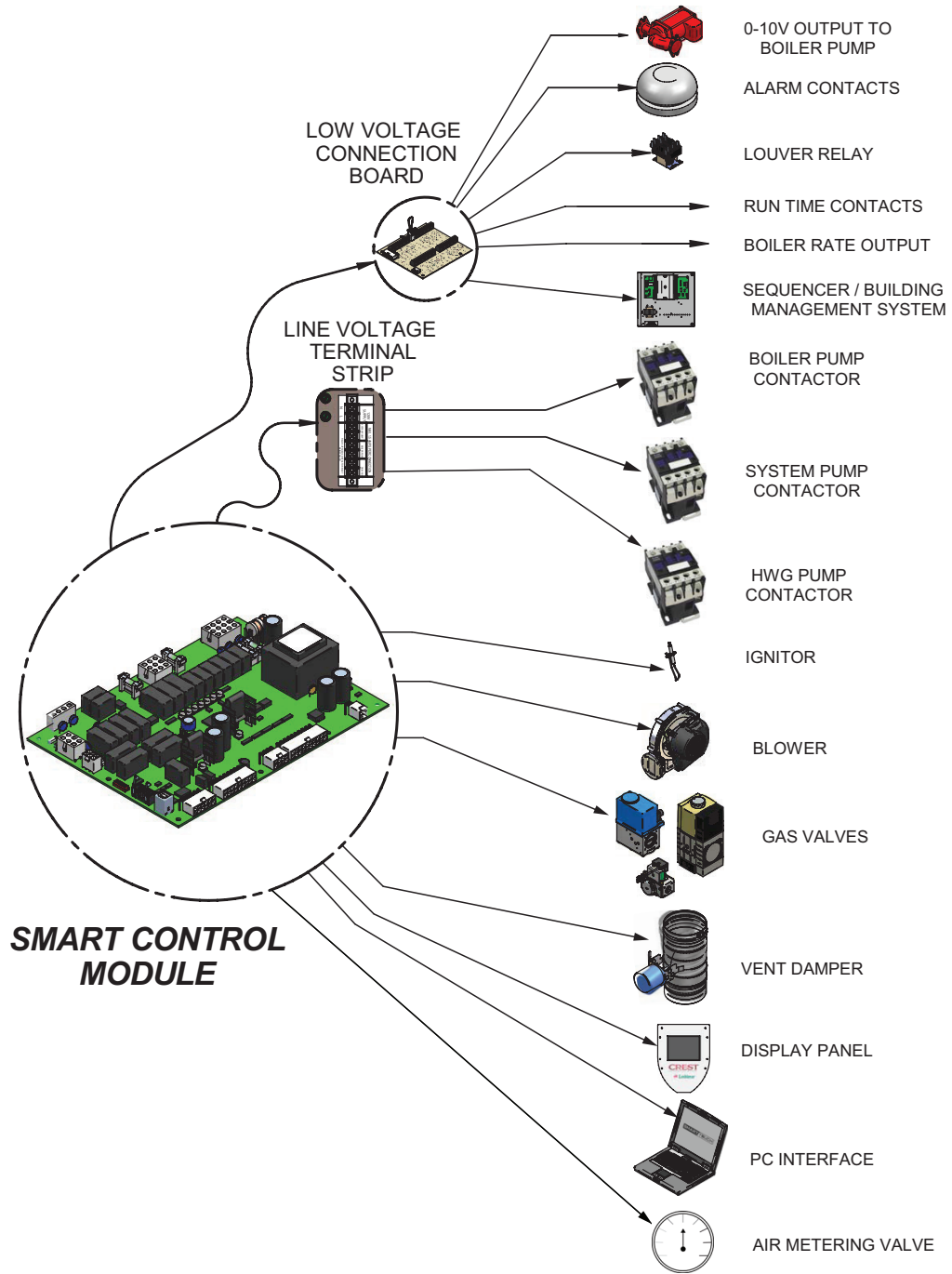

1 Service *(continued)*

Table 1A Sequence of Operation

Sequence of operation

Note: This unit is equipped with two (2) gas train systems. Gas Train 1 will fire first. If the demand cannot be met by the first gas train, the second gas train (Gas Train 2) will fire.

1.	Upon a call for heat, the control turns on the appropriate pumps (system and boiler pumps for a space heating call, HW pump for a hot water generator call).
2.	The control confirms that the low water cutoff contacts are closed and energizes the louvers (optional) and damper (optional) relays.
3.	The control confirms that the proof of closure switch (Model FB 6001 only), gas pressure switch, blocked drain switch, limits, louver proving switch (optional) and damper proving switch (optional) contacts close. The proof of closure valve (FB 6001 only) opens and the Pre-Purge cycle begins.
4.	The control confirms the blower is up to the desired speed, and the air pressure switch is closed.
5.	Once the Pre-Purge cycle is complete, the control lowers the blower speed, initiates sparking of the ignition electrode, and opens gas valve 1.
6.	After a short wait, the control stops sparking and checks for the presence of flame current through the flame sense electrode.
7.	If the control does not detect flame current: Models FB0751-2001 - The control will repeat the ignition cycle after the required post purge and pre-purge cycles. Models FB2501-6001 - Loss of flame will result in safety shutdown and lockout, requiring manual reset.
8.	If the control detects flame current, the control will hold the blower speed constant for a few seconds to allow the flame to stabilize, then begin modulating the firing rate in order to maintain the controlling sensor to the desired set point temperature.
9.	If the current call for heat is for space heating and a HW call for heat becomes active, the control will turn on the HW pump relay output, then turn off the boiler pump. It will then modulate the blower speed in order to maintain the outlet temperature to the desired HW outlet set point temperature.
10.	If the boiler is unable to maintain the desired set point using gas valve 1, control will transition to the larger gas valve 2. The blower will modulate to a fixed speed and the air metering valve will start to open. As it opens, gas valve 2 will be turned on and gas valve 1 will be turned off. If the flame should be lost at any time during this process, the control will immediately try to reignite the burner. Once the air metering valve is fully open and the flame is confirmed to be present, the control will hold the fan speed constant for a few seconds in order to allow the flame to stabilize. The fan speed will then modulate as needed to maintain the set point. If the flame is not present when the air metering valve is fully open, the boiler will go through a complete shutdown and restart of the burner. If the heat load should decrease sufficiently, a similar process is used to transition from gas valve 2 to gas valve 1.
11.	Once both the space heating and HW calls for heat are satisfied, the control will turn off the gas valve and begin the Post-Purge cycle. Any pumps that are running will begin their respective Pump Delay cycles.
12.	At the end of the Post-Purge cycle, the louver relay contacts will de-energize.
13.	The control verifies that the blowers stop running and the blower proving switches open.
14.	At the end of the Pump Delay cycle(s), the pump(s) will be turned off.

1 Service

Initial Setup Screen

Figure 1-2 Settings Screen

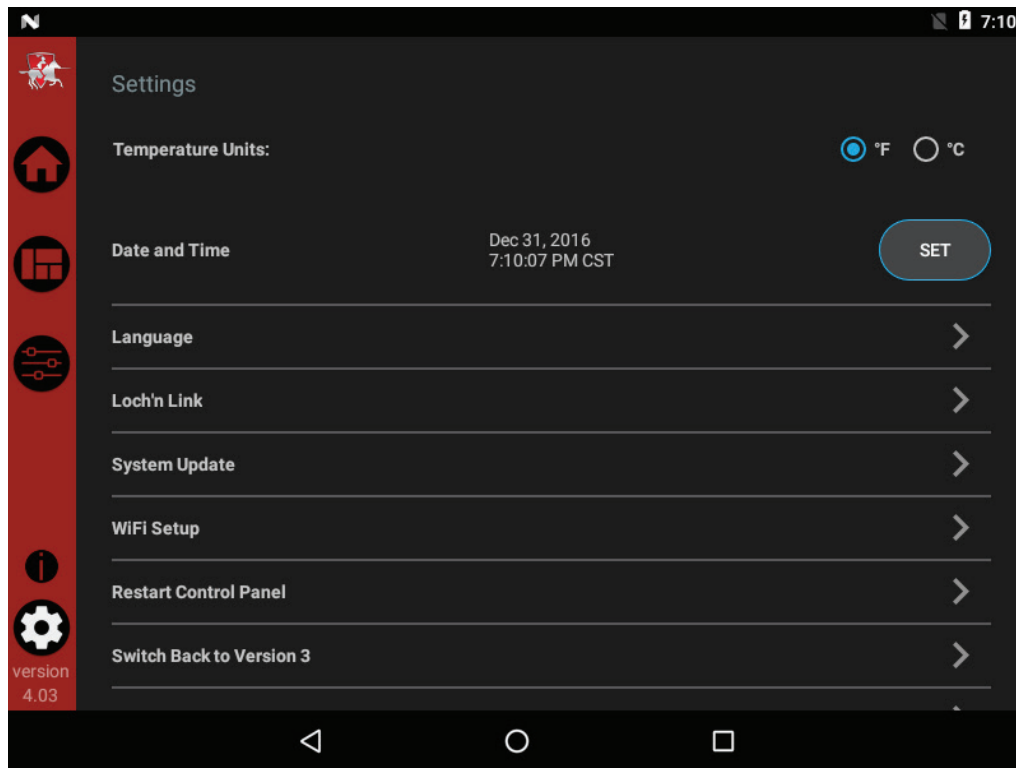

Initial Setup

Clock and Date

The control uses an internal clock for the night setback feature and for logging of events. For these features to work correctly, the clock must be set when the boiler is first installed or anytime the boiler has been powered off for more than four (4) hours. This parameter must be accessed to set the clock. If the unit is connected to the internet, the time will adjust based on the time zone selected.

Temperature units (°C / °F)

The control can be configured to display temperature in either °C or °F.

1 Service *(continued)*

Viewable and changeable control parameters

CAUTION Before changing parameters, note the settings so that the unit can be returned to its original operating parameters.

Set Point Screens

Figure 1-3 Set points HW_Screen A

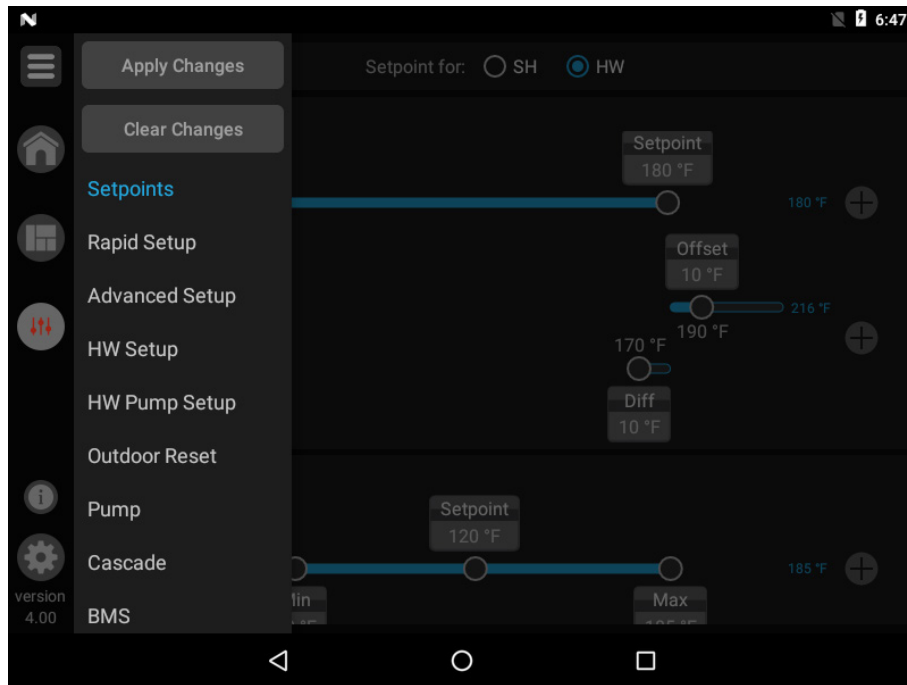
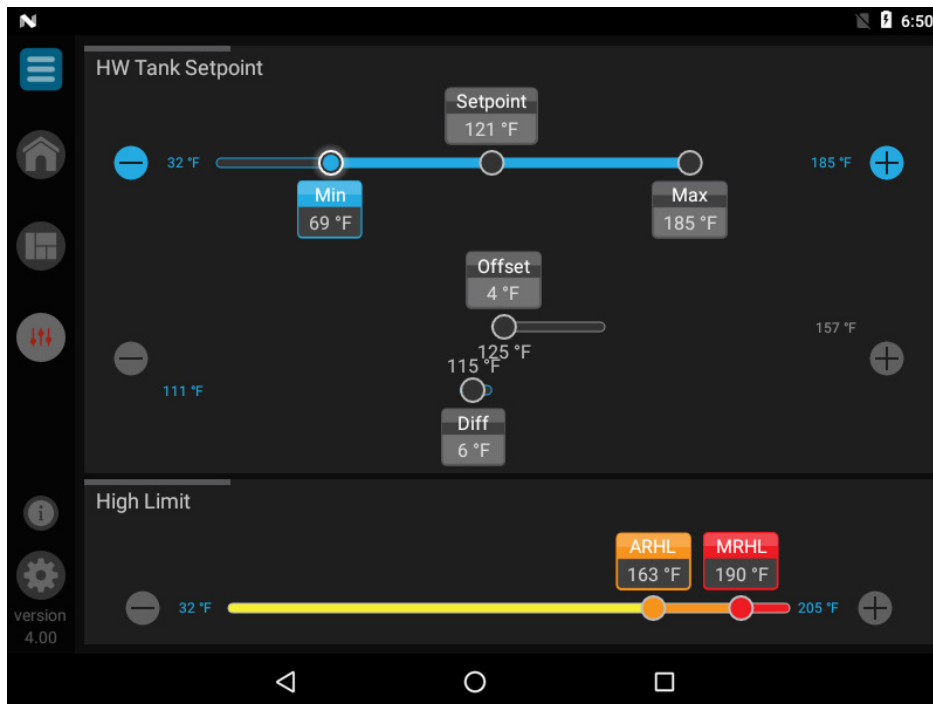

Figure 1-4 Set points HW_Screen B



1 Service

Figure 1-5 Set points SH_Screen A

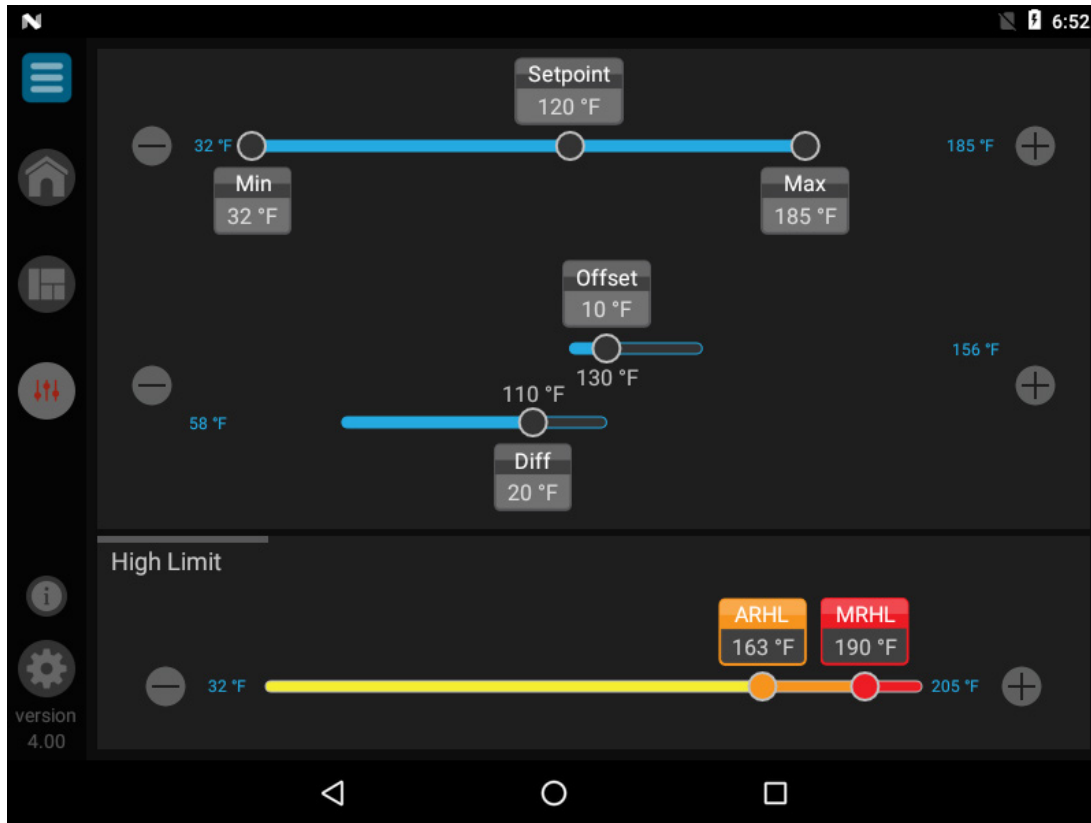

Table 1B Set Points (This table lists control module parameters; use the sub-tab under the Setup tab to access them.)

Menu	Parameter Name (as shown on the LCD screen)	Min	Max	Default
		Value	Value	Value
SET POINTS	Space Heat 1 Set point: Set point	32	185	120
	Space Heat 1 Set point: Min	32	185	32
	Space Heat 1 Set point: Max	32	185	185
	Space Heat 1 Set point: Offset	0	36	9.9
	Space Heat 1 Set point: Diff	0	72	19.8
	System Pump Anti-Seize Time	0	40	0.33
	High Limit: ARHL	32	200	199.4
	High Limit: MRHL	0	90	0
	HW Boiler Set point: Set point	N/A	N/A	N/A
	HW Boiler Set point: Offset	N/A	N/A	N/A
	HW Boiler Set point: Differential	N/A	N/A	N/A
	HW Tank Set point: Set point	N/A	N/A	N/A
	HW Tank Set point: Min	N/A	N/A	N/A
	HW Tank Set point: Max	N/A	N/A	N/A
HW Tank Set point: Diff	N/A	N/A	N/A	

1 Service *(continued)*

Set Points

Space Heat 1 Set Point: Set point

The SH set point sets the water temperature set point used during space heating calls.

Space Heat 1 Set Point: Min

The SH minimum set point sets the minimum water temperature set point that can be used for space heating operation. The user or installer will not be able to program the control with a lower SH set point.

Space Heat 1 Set Point: Max

The SH maximum set point sets the maximum water temperature set point that can be used for space heating. The user or installer will not be able to program the control with a higher SH set point.

Space Heat 1 Set Point: Offset

The SH offset sets how many degrees above set point the temperature can go before the boiler will shut off.

Space Heat 1 Set Point: Differential

The SH differential sets how many degrees below the offset the temperature has to drop before the boiler turns back on.

High Limit: ARHL

The SMART TOUCH control contains an integral Auto Reset High Limit (ARHL) on the outlet of the heat exchanger. Once the outlet temperature exceeds the ARHL set point, the boiler will shut down and lock out. Once the outlet temperature has dropped below this set point, the RESET button on the LCD display can be pressed to reset this lockout. If RESET is not pressed, the control will automatically reset the lockout after five (5) minutes.

High Limit: MRHL

The SMART TOUCH control contains an integral Manual Reset High Limit (MRHL) on the outlet of the heat exchanger. Once the outlet temperature exceeds the MRHL set point, the boiler will shut down and lock out. Once the outlet temperature has dropped below this set point, the RESET button on the LCD display must be pressed to clear this lockout.

HW Boiler Set Point: Set point

When a HW call for heat becomes active, the control will use the HW boiler set point to determine the firing rate of the boiler based on the boiler outlet water temperature.

HW Boiler Set Point: Offset

This parameter reflects the degrees above HW boiler set point the outlet temperature can go before the boiler will shut off.

HW Boiler Set Point: Differential

This parameter reflects the degrees below HW boiler offset the outlet temperature has to go before the boiler turns on.

HW Tank Set Point: Set Point

By installing a tank sensor, the SMART TOUCH control can perform the tank thermostat function. The SMART TOUCH control automatically detects the presence of this sensor, and generates a call for heat when the tank temperature drops below the tank set point minus the differential, and finishes the call for heat when the tank temperature reaches tank set point.

HW Tank Set Point: Min

This setting controls the minimum user set point for the tank temperature.

HW Tank Set Point: Max

This setting controls the maximum user set point for the tank temperature.

HW Tank Set Point: Differential

When a tank sensor is installed, the tank temperature must drop this amount below the tank set point before the boiler will turn on.

1 Service

Outdoor Reset Screen

Figure 1-6 Outdoor Reset A

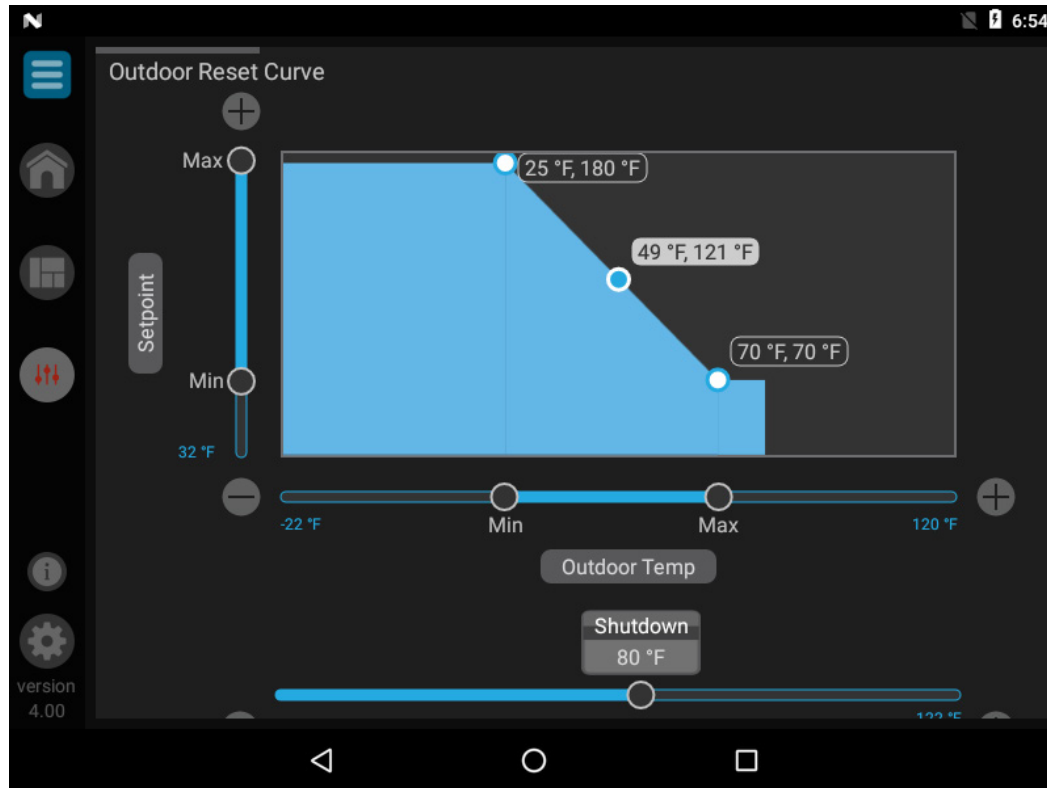

Table 1C Outdoor Reset (This table lists control module parameters; use the sub-tab under the Setup tab to access them.)

Menu	Parameter Name (as shown on the LCD screen)	Min	Max	Default
		Value	Value	Value
OUTDOOR RESET	Set point Max	32	185	180
	Set point Min	32	185	68
	Outdoor Temperature: Min	-22	86	23
	Outdoor Temperature: Max	-22	86	86
	Outdoor Temp: Shutdown	32	122	79.7
	Outdoor Temp: Diff	32	122	79.7
	Shift OA Reset Curve	-27	27	0
	Boost Time	0	250	20
	Boost Temperature	0	25	0

1 Service *(continued)*

Outdoor Reset

Outdoor Reset Curve

The Outdoor Temp Min and Set Point Max define the upper point of the Outdoor Reset Curve. The lower point is defined by the Outdoor Temp Max and Set Point Min. The curve will level out at Set Point Min for temperature warmer than Outdoor Temp Max. The curve will continue on if the set point (set on Set Points Screen) is above the Set Point Max. The curve will be shortened if the set point is below Set Point Max.

Outdoor Temperature: Shutdown

When the outdoor temperature rises above this point, the control will block all SH demands (HW demands will still be active).

Outdoor Temperature: Differential

The outdoor air shutdown differential parameter is the number of degrees below parameter the outdoor air temperature must go before the boiler will respond to a SH demand.

Shift OA Reset Curve

The shift reset curve parameter shifts the actual set point above or below the calculated set point by the number of degrees in this parameter.

Boost Time

The boost time parameter sets the amount of time that must elapse with a SH demand before the water temperature calculated set point will be increased.

Boost Temperature

If a SH demand lasts longer than the programmed boost time delay setting and there have been no HW demands, the control will increase the water temperature set point by the amount in this parameter. If the SH demand continues through another time period, the set point will be increased again. This will continue until either the SH demand ends, a maximum of 20 increases has occurred, or the maximum set point has been reached. Once the SH demand has been satisfied the set point will revert back to its calculated setting.

1 Service

Ramp Delay Screen

Figure 1-7 Ramp Delay

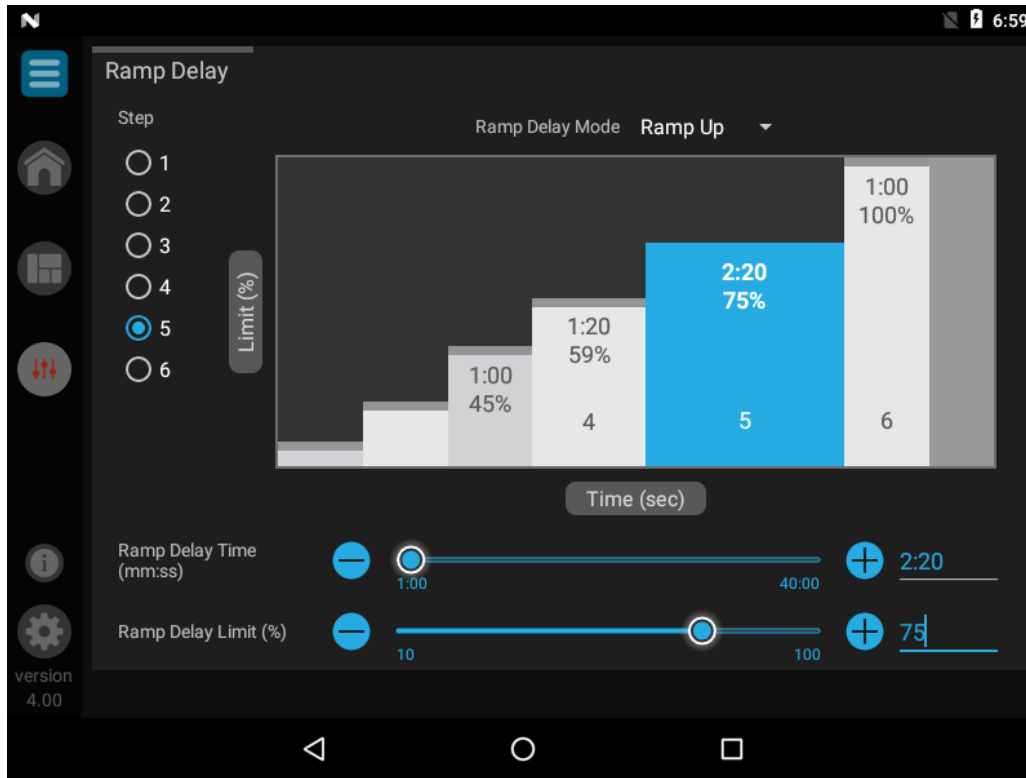

Table 1D Ramp Delay (This table lists control module parameters; use the sub-tab under the Setup tab to access them.)

Menu	Parameter Name (as shown on the LCD screen)	Min	Max	Default
		Value	Value	Value
RAMP DELAY	Ramp Delay Mode	N/A	N/A	N/A
	Step 1: Ramp Delay Time	1	40	2
	Step 1: Ramp Delay Limit (%)	10	100	20
	Step 2: Ramp Delay Time	1	40	2
	Step 2: Ramp Delay Limit (%)	10	100	30
	Step 3: Ramp Delay Time	1	40	2
	Step 3: Ramp Delay Limit (%)	10	100	40
	Step 4: Ramp Delay Time	1	40	1
	Step 4: Ramp Delay Limit (%)	10	100	55
	Step 5: Ramp Delay Time	1	40	1
	Step 5: Ramp Delay Limit (%)	10	100	75
	Step 6: Ramp Delay Time	1	40	1
	Step 6: Ramp Delay Limit (%)	10	100	100

1 Service *(continued)*

Ramp Delay

Ramp Delay (Enable / Disable)

This parameter allows the installer to enable or disable the SH ramp delay.

SH Ramp Delay

The SMART TOUCH CON•X•US Interface can be programmed to limit the firing rate for a fixed period of time at the start of a space heating demand. There are six (6) possible limits, each with their own time delay. The first limit applies as soon as the burner starts. Once its time delay expires, the second limit is applied and its timer begins. The control steps through these limits until the 6th (sixth) limit expires. Note, however, that the 6th limit will also limit the rate for the rest of that heat demand.

1 Service

BMS Screens

Figure 1-8 BMS_Screen A

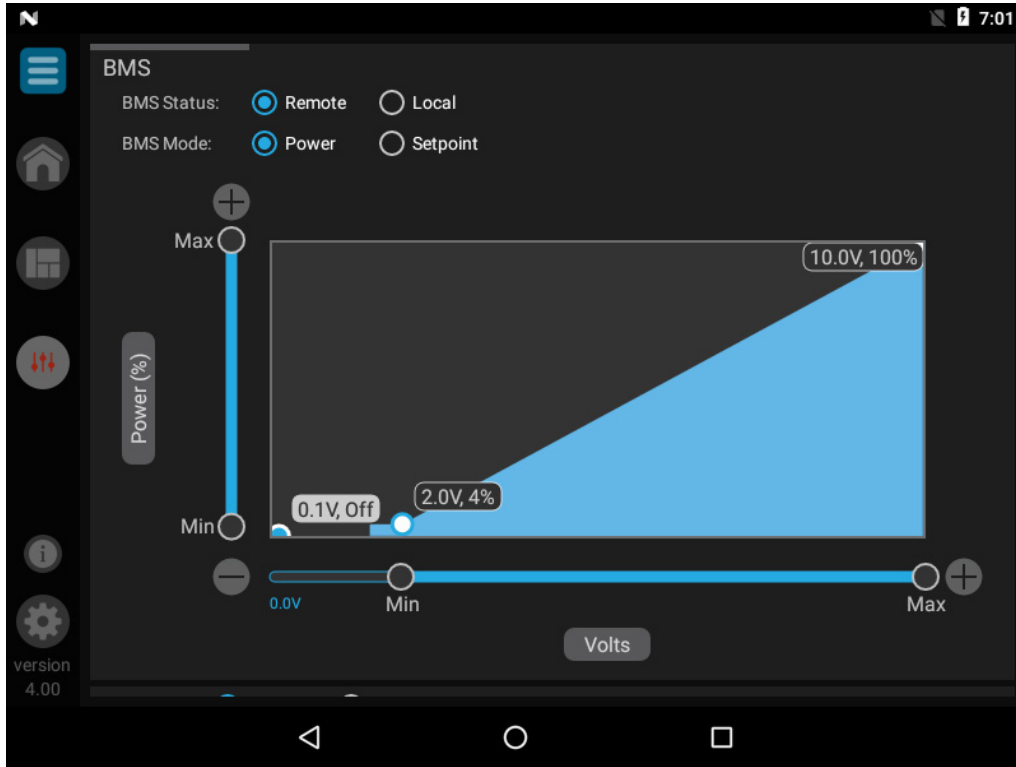
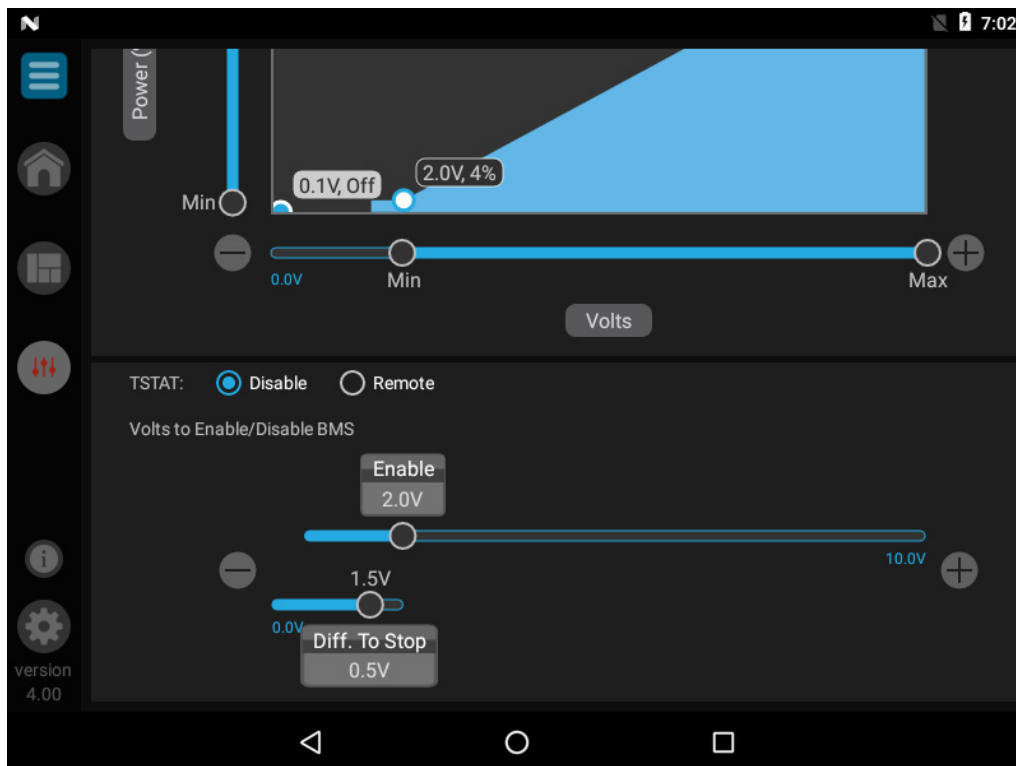

Figure 1-9 BMS_Screen B



1 Service *(continued)*

Table 1E BMS / BAS (This table lists control module parameters; use the sub-tab under the Setup tab to access them.)

Menu	Parameter Name (as shown on the LCD screen)	Min	Max	Default
		Value	Value	Value
BMS	BMS Status	ACTIVE	INACTIVE	INACTIVE
	BMS Mode	POWER	SETPOINT	POWER
	Power (%): Min	4	POWER MAX	4 or 5
	Power (%): Max	POWER MIN	100	100
	Volts: Min	0	VOLTS MAX	2
	Volts: Max	VOLTS MIN	10	10
	Set point (F): Min	32	SET POINT MAX	69.8
	Set point (F): Max	SET POINT MIN	185	179.6
	Volts: Min	0	VOLTS MAX	2
	Volts: Max	VOLTS MIN	10	10
	Volts to Enable / Disable BMS: Enable	0	10	2
	Volts to Enable / Disable BMS: Diff. to Stop	0	10	0.5
	BMS TSAT	ENABLE	DISABLE	DISABLE
	BAS	BAS Active / Inactive	ENABLE	DISABLE
BAS Out of Order Timer		5	120	30

BMS

BMS (Active / Inactive)

The set point or modulation of the boiler may be controlled through the 0 - 10V Building Management System (BMS) input. When the parameter is set to INACTIVE, the 0 - 10V input will be ignored. When set to ACTIVE, the set point or modulation will be controlled by the voltage on the 0 - 10V input, as described below.

BMS Mode (Power / Set Point)

When BMS is set to ACTIVE, this parameter will determine if the voltage on the 0 - 10V BMS input is converted to modulation or a set point. When set to POWER, the voltage determines the modulation of the boiler. When set to SETPOINT, voltage determines the set point used by the boiler.

BMS Volts at Minimum (Power or Set Point)

When BMS is set to ACTIVE, this parameter will determine the voltage on the 0 - 10V BMS input that represents the minimum modulation or set point. Any voltage less than this value will not change the modulation or set point used by the boiler.

BMS Volts at Maximum (Power or Set Point)

When BMS is set to ACTIVE, this parameter will determine the voltage on the 0 - 10V BMS input that represents the maximum modulation or set point. Any voltage above this value will not change the modulation or set point used by the boiler.

BMS Rate at Minimum Volts

This parameter is visible only when BMS Mode is set to POWER. The value of this parameter determines the modulation rate when the voltage on the 0 - 10V BMS input is equal to or less than the BMS Volts at Minimum parameter value.

BMS Rate at Maximum Volts

This parameter is visible only when BMS Mode is set to POWER. The value of this parameter determines the modulation rate when the voltage on the 0 - 10V BMS input is equal to or more than the BMS Volts at Maximum parameter value.

1 Service

BMS Set Point at Minimum Volts

This parameter is visible only when the BMS Mode is set to SETPOINT. The value of this parameter determines the set point when the voltage on the 0 - 10V BMS input is equal to or less than the BMS Volts at Minimum parameter value.

BMS Set Point at Maximum Volts

This parameter is visible only when BMS Mode is set to SETPOINT. The value of this parameter determines the set point when the voltage on the 0 - 10V BMS input is equal to or more than the BMS Volts at Maximum parameter value.

BMS Volts to Enable

When BMS is set to ACTIVE, the boiler may be enabled either through the ENABLE input, or by the voltage on the 0 - 10V BMS input (see BMS Tstat Enable Mode below). If enabled through the voltage on the 0 - 10V BMS input, the value of this parameter determines the voltage at which the boiler becomes enabled.

Differential to Stop BMS Demand

When BMS is set to ACTIVE, and the boiler is enabled through the voltage on the 0 - 10V BMS input, the voltage must go below the BMS Volts to Enable value by this amount in order to end the demand.

BMS Tstat Enable Mode

In order to use the ENABLE input to enable the boiler, this parameter must be set to ACTIVE. To use the voltage on the 0 - 10V BMS input to enable the boiler, this parameter must be set to INACTIVE.

BAS

BAS Active / Inactive

The boiler is capable of being monitored and/or controlled by a Building Automation System (BAS) through either a ModBus RTU or BACnet MS/TP communication system. In addition, it can communicate through a BACnet TCP/IP system with the use of an optional gateway. See the Crest ModBus Manual (100161012) for details on the points that are available. If the boiler is to be monitored by the BAS system, the BAS Active / Inactive parameter should be set to INACTIVE. If the boiler is to be controlled through a BAS system, the BAS Active / Inactive parameter must be set to ACTIVE.

BAS Out of Order Timer

When the boiler is being controlled by the BAS system, the commands it sends to the boiler must be refreshed periodically. If the boiler does not receive a command for too long, the boiler will revert to its local readings (e.g., enable input, temperatures, etc.) until a new command is received from the BAS system. For most commands, this timeout is fixed at 10 minutes. Certain commands (0 - 10V BMS voltage, system supply temperature, system return temperature, and tank temperature) can change quickly, so they need to be refreshed more often. The timeout for these commands is controlled by the BAS Out of Order Timer.

1 Service *(continued)*

Advanced Setup Screen

Figure 1-10 Advanced Setup Screen A

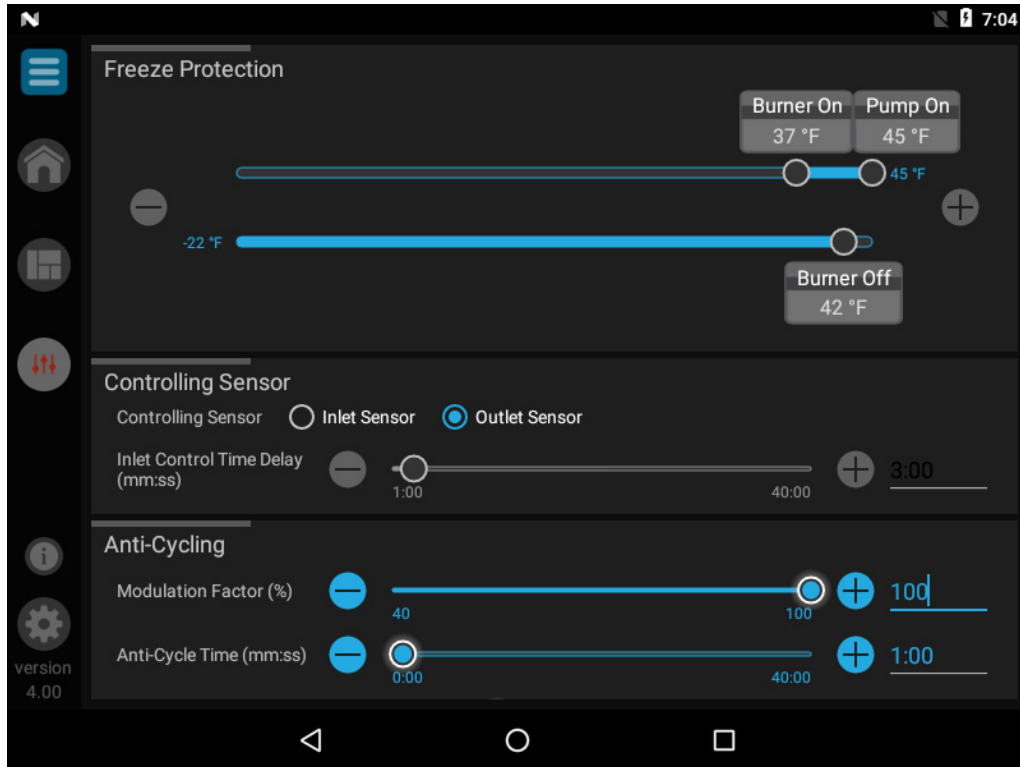
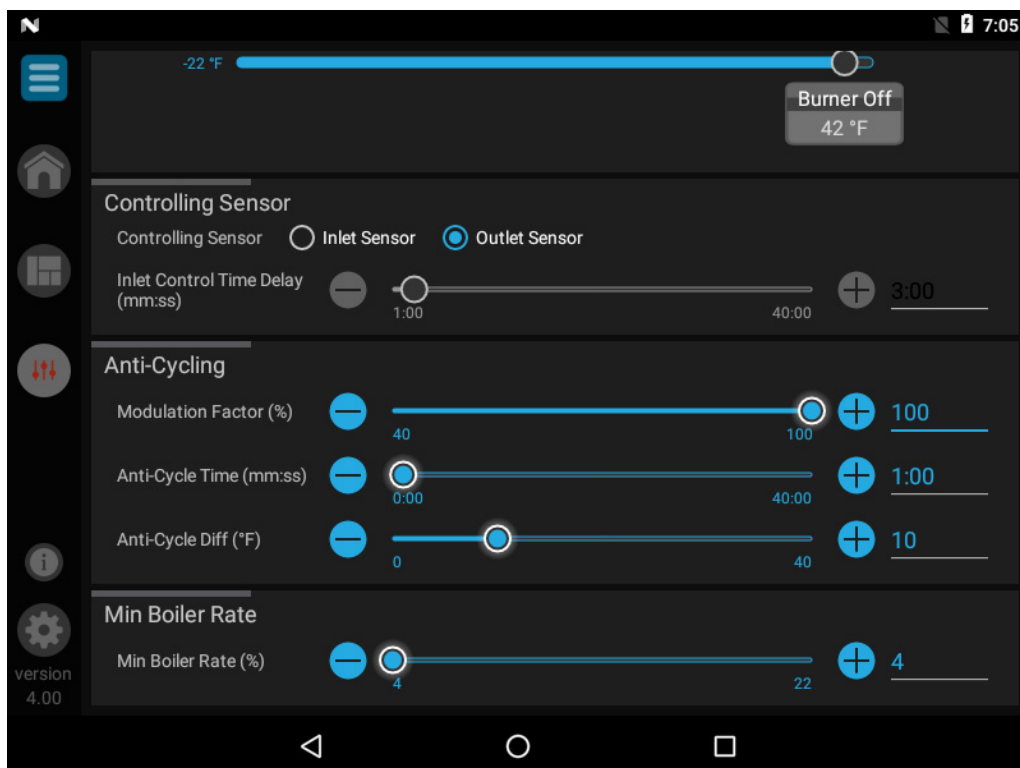

Figure 1-11 Advanced Setup Screen B



1 Service

Table 1F Advanced Setup (This table lists control module parameters; use the sub-tab under the Setup tab to access them.)

Menu	Parameter Name (as shown on the LCD screen)	Min	Max	Default
		Value	Value	Value
ADVANCED SETUP	Freeze Protection; Pump On	-22	45	44.6
	Freeze Protection; Burner On	-22	45	37.4
	Freeze Protection; Burner Off	-22	45	5
	Anti-Cycling Time	0	40	10
	Anti-Cycling Diff	0	54	1
	Controlling Sensor	0	4	2

Advanced Setup

Freeze Protection Pump On

The SMART TOUCH control will turn on the boiler and system pump outputs whenever the inlet temperature drops below this setting. This is done to prevent the water in the heat exchanger from freezing. Certain low-temperature applications (such as snow melt) can operate at temperatures around freezing, so this setting needs to be lowered in these cases. The temperature at which the pump outputs are turned on, can be accessed through the Freeze Protection Pump On parameter.

Freeze Protection Burner Off

Once the burner has started firing due to a low inlet temperature, the inlet temperature must increase by this amount before the burner turns back off. The installer can adjust this differential by accessing the Freeze Protection Burner Off parameter.

Anti-Cycling Time

Once a SH demand has been satisfied, a set amount of time must elapse before the control will respond to a new SH demand. The control will block the new heat demand and anti-cycling will be shown in the display until the time has elapsed or the water temperature drops below the anti-cycling differential. This parameter can be changed by the installer by accessing the Anti-Cycling Time parameter.

Freeze Protection Burner On

If running the pumps does not prevent the inlet temperature from falling closer to freezing, the SMART TOUCH control will fire the burner at low fire if in the ON state. The installer can adjust the temperature at which the burner fires by adjusting the Freeze Protection Burner On parameter.

Anti-Cycling Differential

The control will bypass the anti-cycling time if the inlet water temperature drops too much. The control will use the inlet water temperature at the time the boiler shuts off as the starting point. If the inlet temperature drops below this temperature parameter the control will abort anti-cycling and allow the boiler to fire. This parameter can be changed by the installer by the Anti-Cycling Differential parameter.

Controlling Sensor

The SH controlling sensor parameter selects the sensor the control will use to regulate the boiler firing rate. This parameter is adjustable by accessing the Controlling Sensor parameter. The sensor selections are as follows: The outlet sensor regulates the firing rate based on the outlet water temperature of the boiler and the inlet sensor regulates the firing rate based on the inlet water temperature of the boiler. If the outlet sensor is selected, and the optional system supply sensor is connected, the control will regulate the firing rate based on the system supply sensor temperature.

1 Service *(continued)*

Night Setback Screen

Figure 1-12 SH Night Setback

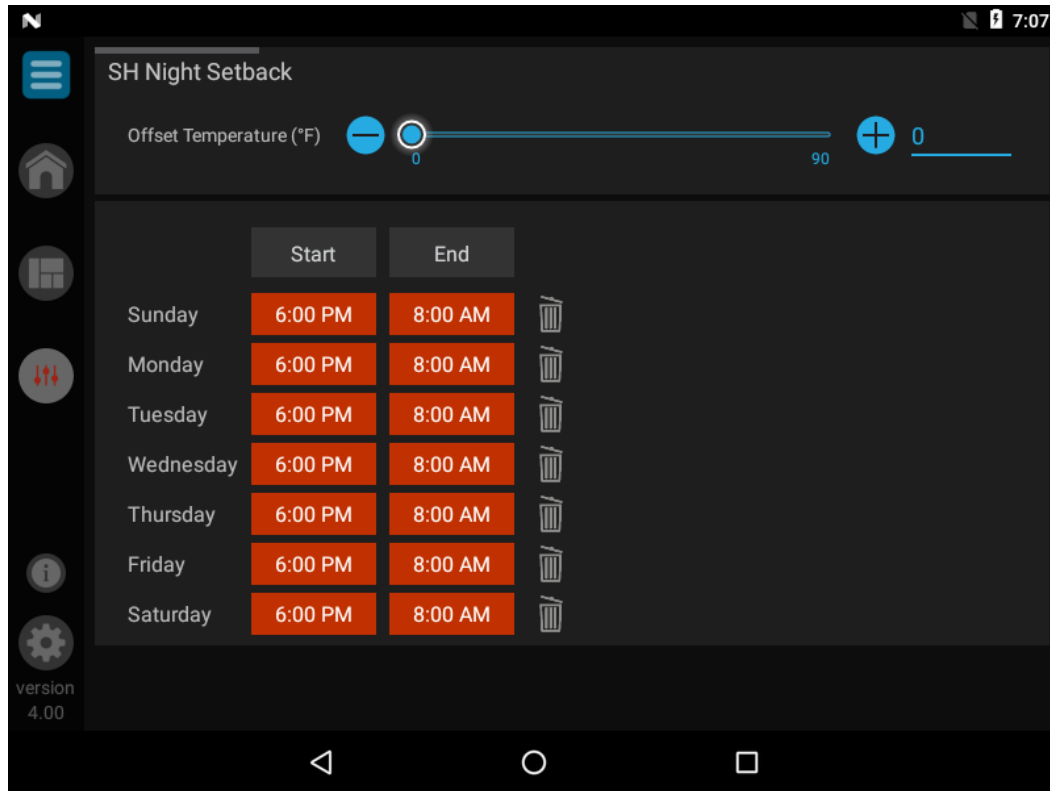

Table 1G SH/HW Night Setback (This table lists control module parameters; use the sub-tab under the Setup tab to access them.)

Menu	Parameter Name (as shown on the LCD screen)	Min	Max	Default
		Value	Value	Value
SH/HW NIGHT SETBACK	Offset Temperature (F)	0	90	0

SH/HW Night Setback

Offset Temperature

Once the internal clock has been set correctly, the SH night setback feature can be used to program a lower set point. The value of this parameter will be subtracted from the normal set point to determine the set point used during night setback. The temperature range for this parameter is 0°F to 90°F (50°C). The feature is turned off with a setting of 0°F.

Pump Screen

Figure 1-13 Pump Screen A

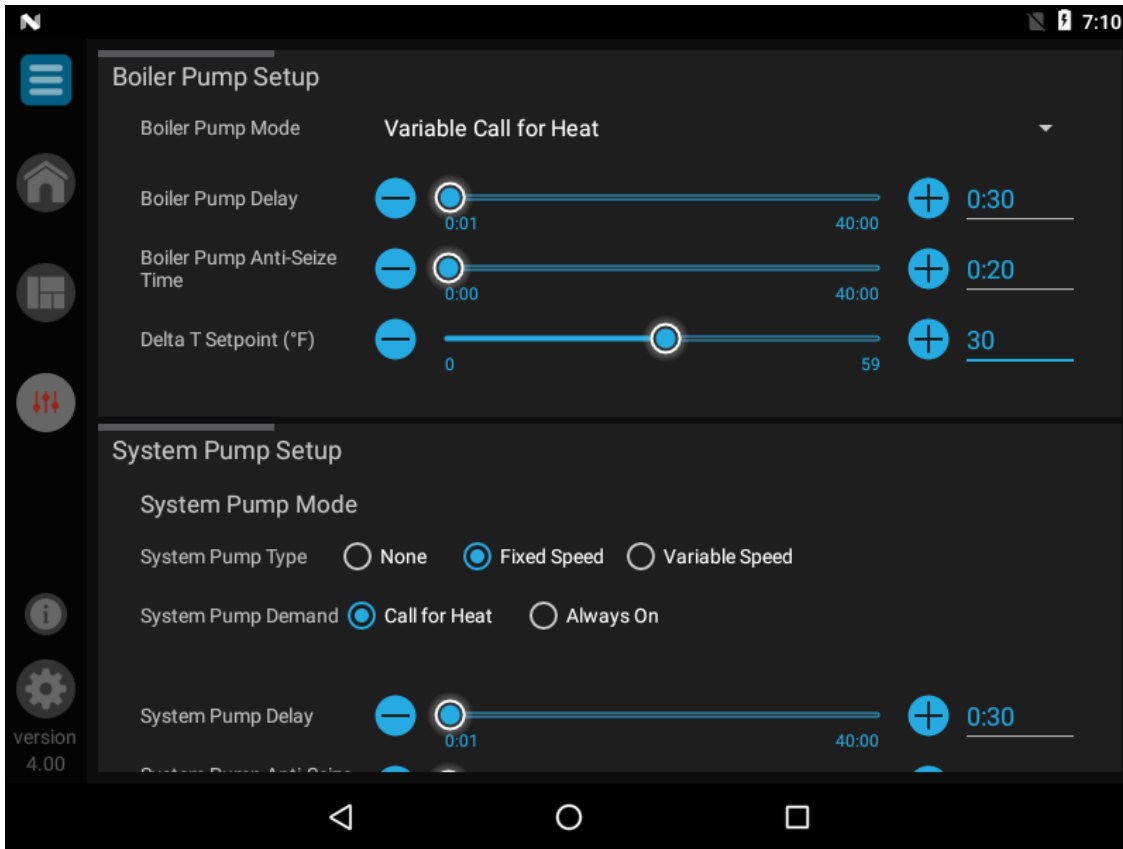
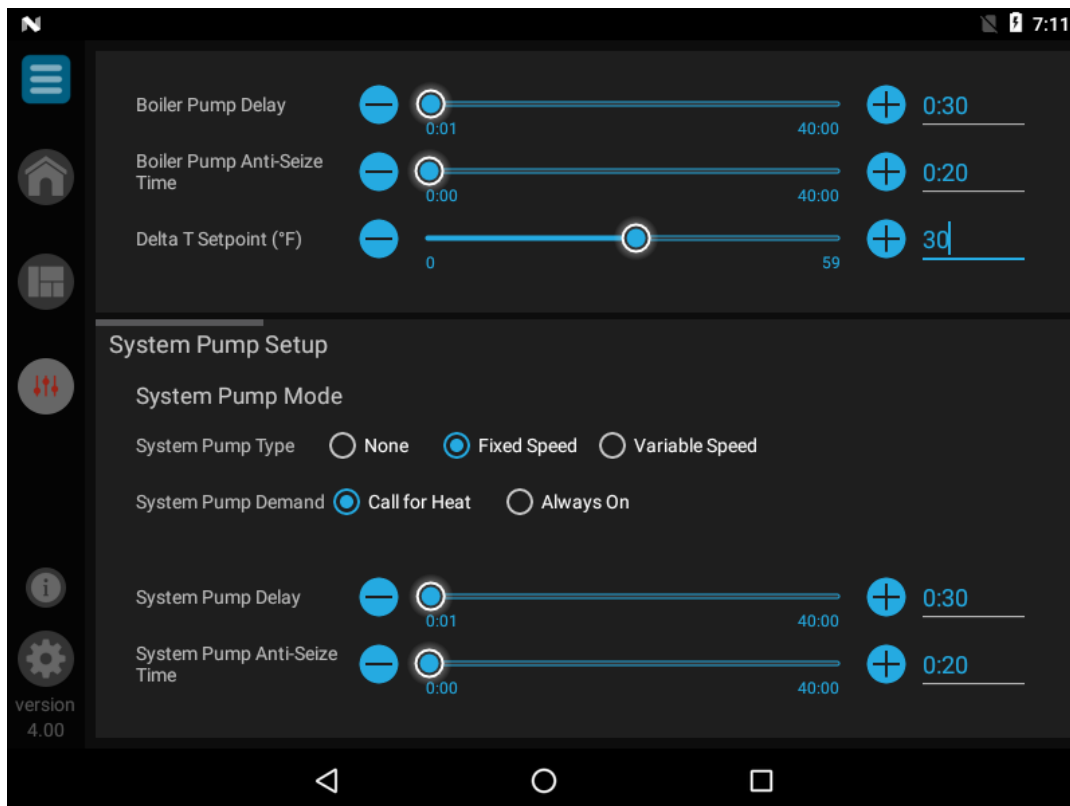

Figure 1-14 Pump Screen B



1 Service *(continued)*

Table 1H Pumps (This table lists control module parameters; use the sub-tab under the Setup tab to access them.)

Menu	Parameter Name (as shown on the LCD screen)	Min	Max	Default
		Value	Value	Value
PUMPS	System Pump Mode	N/A	N/A	N/A
	Boiler Pump Delay	0:00	40:00	0:30
	Boiler Pump Anti-Seize Time	0:00	40:00	0:33
	System Pump Mode	N/A	N/A	N/A
	System Pump Delay	0:00	40:00	0:30
	System Pump Anti-Seize Time	0	40:00	0:33
	Delta T Set point	0	60	0
HW PUMP SETUP	HW System Pump Mode	N/A	N/A	N/A
	HW Pump Delay	0.5	2400	30
	HW Pump Anti-Seize Time	0	40	0.33
HW SETUP	HW Type	NORMAL	ZONE	NORMAL
	HW/SH Switching Time	0	240	30
	SH/HW Switching Time	0	240	30
	HW Max Fan Speed	10	100	100

1 Service

Pumps

System Pump Mode

The SMART TOUCH control is able to control the system pump in 5 different ways. The options are as follows:

1. ON with a call for heat, with a constant speed.
2. ON with a call for heat, with a variable speed input.
3. Always ON, with a constant speed, except during outdoor shutdown.
4. Always ON, with a variable speed input, except during outdoor shutdown.
5. Always OFF (not connected).

For options 2 and 4, the speed of the system pump is controlled by a separate control system. The pump speed is sent to the 0-10V pump speed input on the boiler.

Boiler Pump Delay

The SH pump delay parameter sets the length of time the boiler pump will run after a SH demand has been satisfied.

Boiler Pump Anti-Seize Time

If the boiler pump does not run for 24 hours, it will be turned on briefly to prevent it from seizing. The length of time it runs is determined by the Boiler Pump Anti-Seize Time parameter.

Boiler Pump Mode

The SMART TOUCH control is able to control the boiler pump in 3 different ways. The options are as follows:

1. ON with a call for heat, with a constant speed.
2. ON with a call for heat, with a variable speed output.
3. Always OFF (not connected).

System Pump Delay

The system pump delay parameter sets the length of time the system pump (if connected) will run after a SH demand has been satisfied.

System Pump Anti-Seize Time

If the boiler pump does not run for 24 hours, it will be turned on briefly to prevent it from seizing.

ΔT Set Point

The SMART TOUCH control includes a 0 - 10Vdc output for controlling the speed of a variable speed boiler pump. This feature can be used with primary - secondary piping systems only. The speed is regulated in order to, among other things, maintain a minimum delta T across the heat exchanger. This helps reduce the electrical consumption of the boiler pump when the boiler is firing at less than its maximum rate. (This feature is active only when a system supply sensor is installed).

HW System Pump Mode

This parameter allows the installer to determine how the system pump responds to a HW call for heat. The parameter can be adjusted through the HW System Pump Mode parameter. Select **Always Off** if you want the system pump to always turn off during a HW call for heat. Select **Always On** if you want the system pump to always turn on during a HW call for heat. Select **Normal** if you want the system pump to ignore the HW call for heat and operate based on the System Pump Mode setting only.

HW Pump Delay

The HW pump delay parameter sets the length of time the HW pump (if connected) will run after a HW demand has been satisfied. This parameter is adjustable by the installer by accessing the HW Pump Delay parameter.

HW Pump Anti-Seize Time

If the boiler pump does not run for 24 hours, it will be turned on briefly to prevent it from seizing. The length of time it runs is determined by the HW Pump Anti-Seize Time.

HW Type

This parameter gives the installer a choice of piping the Hot Water Generator (HW) directly to the boiler, or as a zone in the heating system. This parameter can be adjusted through the HW Type parameter. For direct HW select **Normal**, for treating the HW as a zone, select **Zone**.

HW/SH Switching Time

When a boiler has a HW demand and it receives a space heating demand, the SMART TOUCH control will start a timer. Once the timer expires, it will stop the HW demand and service the space heating demand. This feature does not apply when the HW is programmed as a zone, or in Cascade. The installer can adjust the length of time the boiler will service the HW demand by accessing the HW/SH Switching Time parameter.

SH/HW Switching Time

When a boiler has a space heating demand and it receives a HW demand, it will immediately switch to the HW demand and start a timer. Once the timer has expired, the boiler will switch back to the space heating demand and start another timer. Once this timer expires, it will switch back to the HW demand. This feature does not apply when the HW is programmed as a zone, or in Cascade. The installer can adjust the length of time the boiler will service the space heating demand by accessing the SH/HW Switching Time parameter.

HW Rate Limiting

This parameter determines the maximum rate to be used when heating a HW tank. This setting may be used when the tank is unable to accept all of the BTU's available from the boiler. This parameter may be adjusted by the installer by accessing the HW Rate Limiting parameter.

1 Service *(continued)*

Cascade Screens

Figure 1-15 Cascade Setup

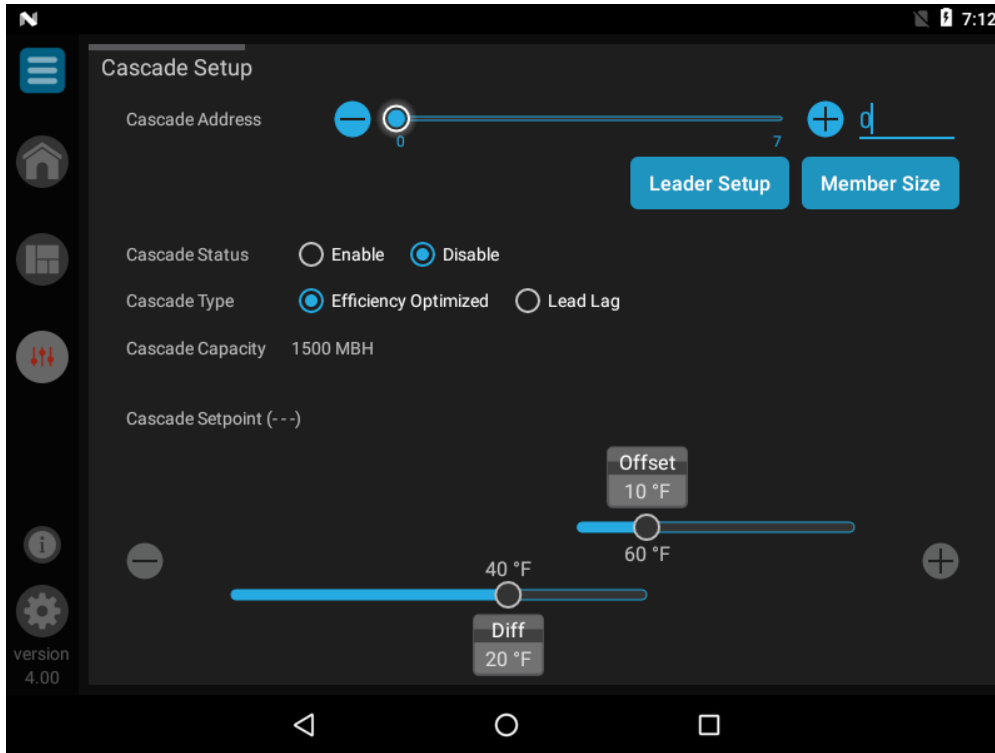
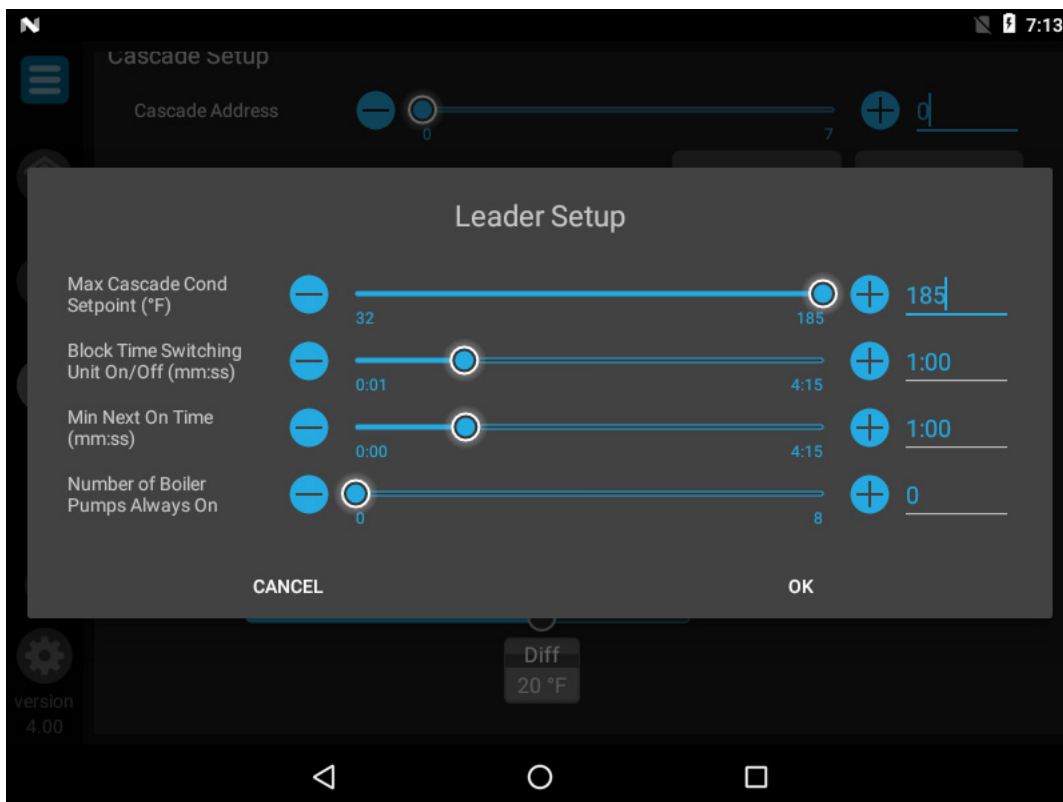

Figure 1-16 Cascade Leader Setup



1 Service

Table 11 Cascade (This table lists control module parameters; use the sub-tab under the Setup tab to access them.)

Menu	Parameter Name (as shown on the LCD screen)	Min	Max	Default
		Value	Value	Value
CASCADE	Cascade Address	0	7	1
	Cascade Status	ENABLE	DISABLE	DISABLE
	Cascade Type	N/A	N/A	N/A
	Cascade Set point: Offset	0	40	10
	Cascade Set point: Differential	0	72	20
	Max Cascade Cond. Set point (F)	32	185	185
	Max Cascade Non-Cond Set point (F)	68	260	185
	Block Time Switching Boiler On / Off	0	4:15	60
	Minimum Next On Time	0	4:15	60
	Rate % to Switch On Next Boiler	1	100	80
	Rate % to Switch Off Last Boiler	1	100	10
	Member Size Code*	0	255	0
	Redundant Leader	Disable	Enable	Disable

Cascade

Cascade Address

The boiler designated as the Leader needs to be programmed with address 0. All the Member boilers require addresses from 1 to 7, and the addresses must be different for each Member. The addresses can be in any order, regardless of the order in which the units are wired together. The outdoor air (if used) and system supply sensor must be connected to the Leader boiler. When the Member 1 boiler is programmed as a Redundant Leader (FIG. 1-17), it allows the Member 1 boiler to automatically assume control of the Cascade should it lose communication with the Leader boiler. When this option is selected, it is **required** that the Member 1 boiler have duplicate connections to the installed external sensors (such as the system supply sensor), control voltages, and heat demand settings of the Leader boiler.

Cascade Status

The boiler is part of a group of units sequenced together. The designated Leader unit determines the total output needed from the group based on the set point and controlling sensor reading. It assigns portions of the output to itself (Leader) and the Member units. When Cascade is active, each boiler in the group requires a unique address.

Cascade Type

The two (2) types of Cascade control are listed below:

Efficiency Optimization

This method is used when it is desired to have the most efficient system. When the first boiler reaches a certain rate (default = 80%), it lowers its rate to 40% and turns on the next boiler at 40%. The two (2) boilers then modulate at the

same rate. As the calculated load increases further and both boilers ramp up to 80%, it lowers the rate of the first two (2) boilers to 53% and brings the next boiler on at 53%. The three (3) boilers then modulate together. As the calculated load decreases, the boilers will reach a lower threshold (default = 10%), at which time the last boiler (the third one in this example) will turn off and the Cascade will increase the rates of the remaining boilers to provide the equivalent total output as before ($(3 \times 10\%) / 2 = 15\%$ in this example).

L/L: Lead/Lag

This method is used when it is desired to run the least number of boilers as possible. When the first boiler reaches 100% and calculated demand is still greater, the Cascade will bring on boiler number two. At the same time the first boiler will reduce its firing rate by an amount equal to the initial firing rate of the second boiler. As the calculated demand continues to increase, the first boiler will go to high fire, followed by ramping up the second boiler. If the calculated demand is still increasing once the second boiler reaches 100%, the Cascade will bring on boiler number three and reduce the firing rate of boiler number two by an amount equal to the initial firing rate of the third boiler.

This sequence will continue until the load is matched or all boilers are firing at 100%. When the load begins to decrease, the last boiler to fire will modulate down to low fire and hold there. As the calculated demand continues to decrease, the second to the last boiler will modulate down to low fire. If calculated demand is still decreasing, the last boiler will shut down and the next to the last boiler will increase its firing rate to make up the lost BTU's of the last boiler. If the calculated demand continues to decrease, it will modulate down to low fire and hold there while the next previous boiler starts to modulate down, as before. This will continue until either demand is matched or all boilers have shut down.

1 Service *(continued)*

Cascade Set point Offset

This parameter determines how much the temperature can go above set point before the lead boiler will turn off.

Cascade Set point Differential

This parameter determines how much the temperature must go below the turn off temperature (Set point + Offset) before the lead boiler turns on.

Maximum Cascade Cond and Non-Cond Set point (F)

These types of parameters determine the set point used by the individual boilers in a Cascade. When a boiler is commanded to fire by the Leader boiler, it will attempt to achieve this temperature at its outlet. If any of the boiler outlet temperatures reach the maximum cascade set point, the boiler will then modulate down on its own in order to keep its outlet temperature within the maximum cascade set point. Therefore, these parameters can be used to limit the outlet temperatures of all the boilers in a Cascade. Note that these parameters do not apply when the boiler is heating an indirect HW tank.

Blocking Time Switching Boiler On / Off

In order to prevent units in a Cascade from short cycling, this parameter defines the minimum ON and OFF time for each unit. The installer can adjust this time by accessing the Blocking Time Switching Boiler On / Off parameter.

Minimum Next On Time

In order to reduce the risk of temperature overshoot with a Cascade, this parameter defines the minimum time delay from starting one unit until the next unit may be started.

Number of Boiler Pumps Always On

When multiple Crest boilers are connected in a Cascade, the SMART TOUCH control can keep a minimum number of the boiler pumps running, regardless of how many of the boilers are firing. This is useful in full flow systems where the system flow is provided by the individual boiler pumps.

Rate % to Switch on Next Boiler

When the Cascade is programmed in the Efficiency Optimization Mode, the currently running boilers must ramp up to a certain firing rate before the next boiler in the Cascade will start.

Rate % to Switch off Last Boiler

When the Cascade is programmed in the Efficiency Optimization Mode, the currently running boiler will stop at this rate.

Member Size Code

The member size code parameter is used to determine the maximum power and priority of legacy boilers (i.e., Power-fin) in cascade with the Crest Boiler. The default value for this parameter is 0. When this value is left unchanged, the SMART TOUCH control will automatically assume that any member(s) of the Cascade not communicating their size will be 1,500,000 Btu. The lowest priority will always be given to these units because the SMART TOUCH control will assume they are non-condensing boilers. Changing this parameter is not necessary for Cascade operation. However, the installer can adjust this code by using the PC program. The PC program will calculate the proper code based on the information provided.

Figure 1-17 Cascade Redundant Leader Selected

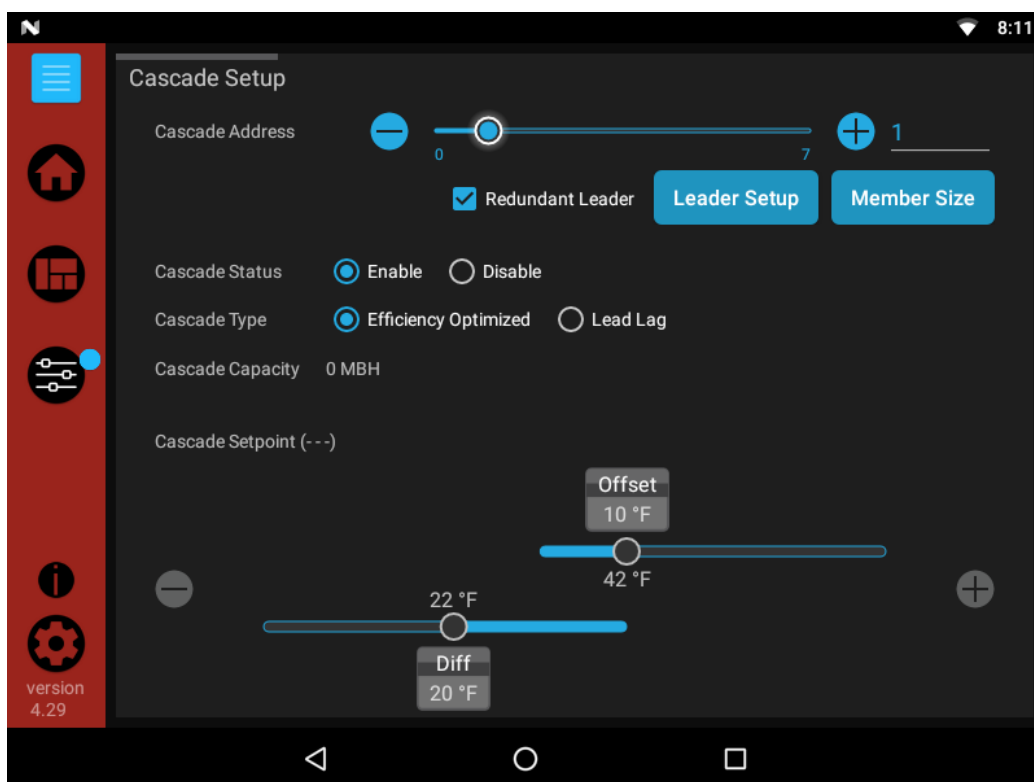

1 Service

Service Screens

The Service Screen allows the integrated control to override all other heat demands and operate Valve 1 and Valve 2 at high fire and low fire conditions. To place the boiler into Service Mode, press the START button. As specified above the integrated control will override all other heat demands, however, all safeties will be active. If no buttons are pressed, the integrated control will automatically revert back to its original status after the “Remaining time in Service” counter expires.

Once the boiler has been placed into Service Mode it will light and modulate to low fire. At any time after that point there are two (2) ways to adjust the firing rate. The first way is by pressing one of the six (6) preset buttons. The second way is by manually adjusting the firing percentage using the “+” and “-” buttons. When Service Mode is no longer needed press the STOP button to return to normal operation.

Figure 1-18 Service Maintenance



1 Service *(continued)*

Figure 1-19 Service Notification

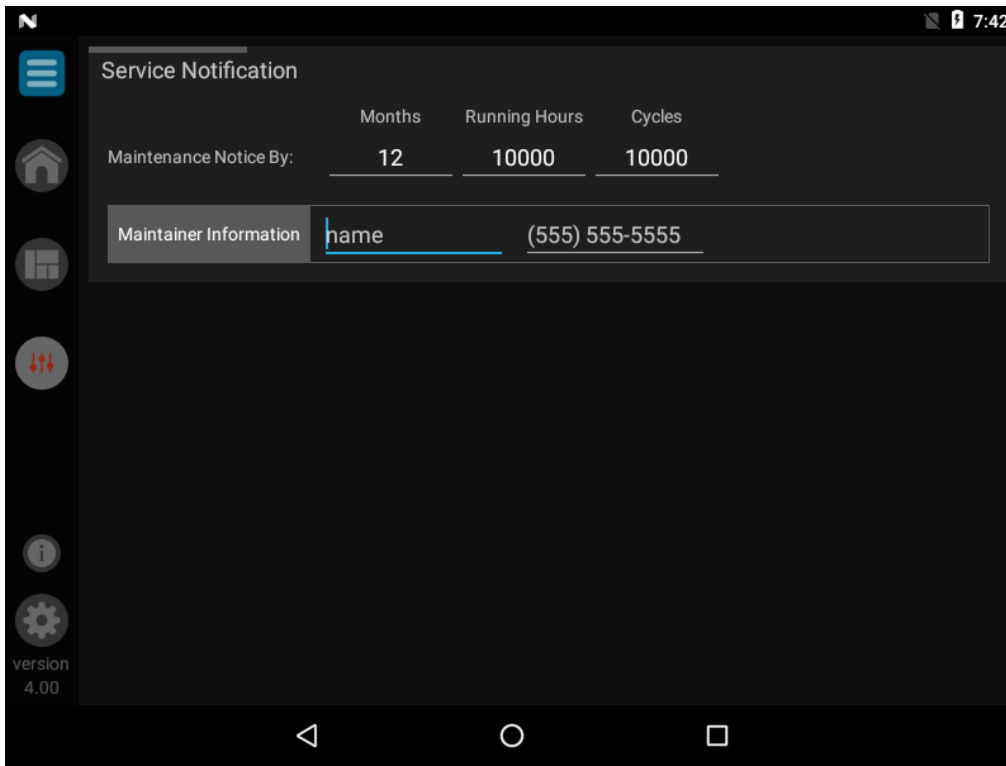

Table 1J Service Notification (This table lists control module parameters; use the sub-tab under the Setup tab to access them.)

Menu	Parameter Name (as shown on the LCD screen)	Min	Max	Default
		Value	Value	Value
SERVICE NOTIFICATION	Maintenance Notice By: Months	0	36	12
	Maintenance Notice By: Running Hours	0	100,000	10,000
	Maintenance Notice By: Cycles	0	100,000	10,000
	Maintainer Information: Name	N/A	N/A	N/A
	Maintainer Information: Phone	N/A	N/A	N/A

Service

Maintenance Notice By: Months

When the boiler control determines that a scheduled service is due based on the months of installation, the boiler display will turn yellow and a new status screen will appear informing the installer that maintenance is required.

Maintenance Notice By: Running Hours

When the boiler control determines that a scheduled service is due based on the hours of actual operation, the boiler display will turn yellow and a new status screen will appear informing the installer that maintenance is required.

Maintenance Notice By: Cycles

When the boiler control determines that a scheduled service is due based on the number of boiler cycles, the boiler display will turn yellow and a new status screen will appear informing the installer that maintenance is required.

Maintainer Information: Name and Phone Number

When a Maintenance Reminder timer or counter has expired, a Maintenance Reminder screen will appear on the display. By programming the installer's name and phone number, this information will appear on the Maintenance Reminder Screen at that time. This can be programmed by accessing parameters L4 and L5. When selected, another menu will appear with PHONE and NAME. Note that the phone number is limited to 10 characters, and the name is limited to 26 characters. Only 0 - 9, A - Z (CAPS only), &, (,), +, and - are permitted.

1 Service

Graph Screens

The Graph Screen consists of two (2) different types of screens. The first screen Short Term Data Screen (three minutes in one second intervals) and the Long Term Data Screen (32 days, 233 average minutes). If a parameter is selected by mistake, it can be de-selected by re-selecting the parameter. A maximum of eight (8) items can be graphed at one time.

Figure 1-20 Graph Select

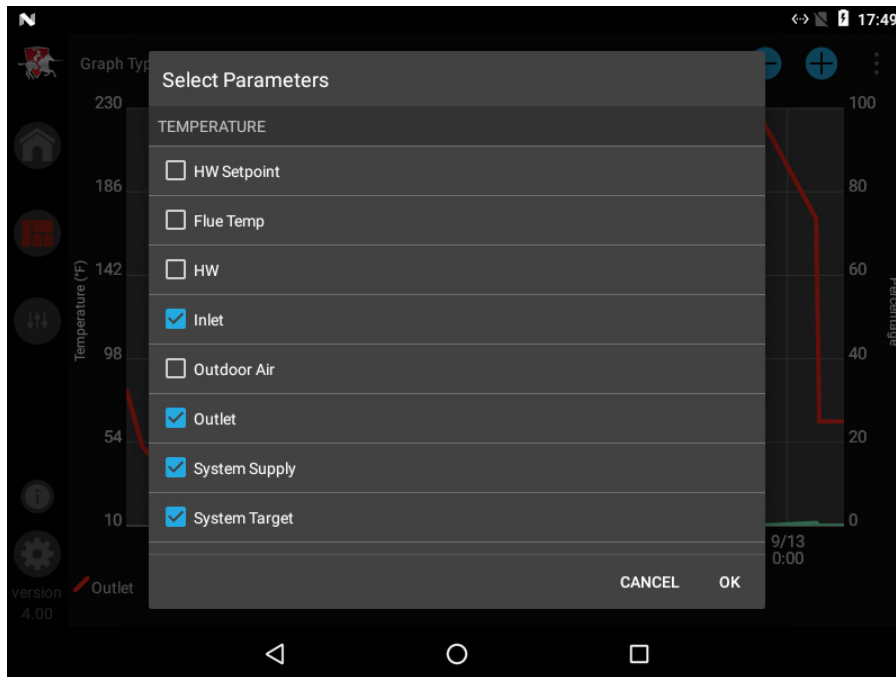

Once the items to be graphed are selected, press the OK button to view the graph. Each item graphed will have a different color line to represent it. The items selected will be shown below the graph along with their corresponding color.

Figure 1-21 Graph Screen

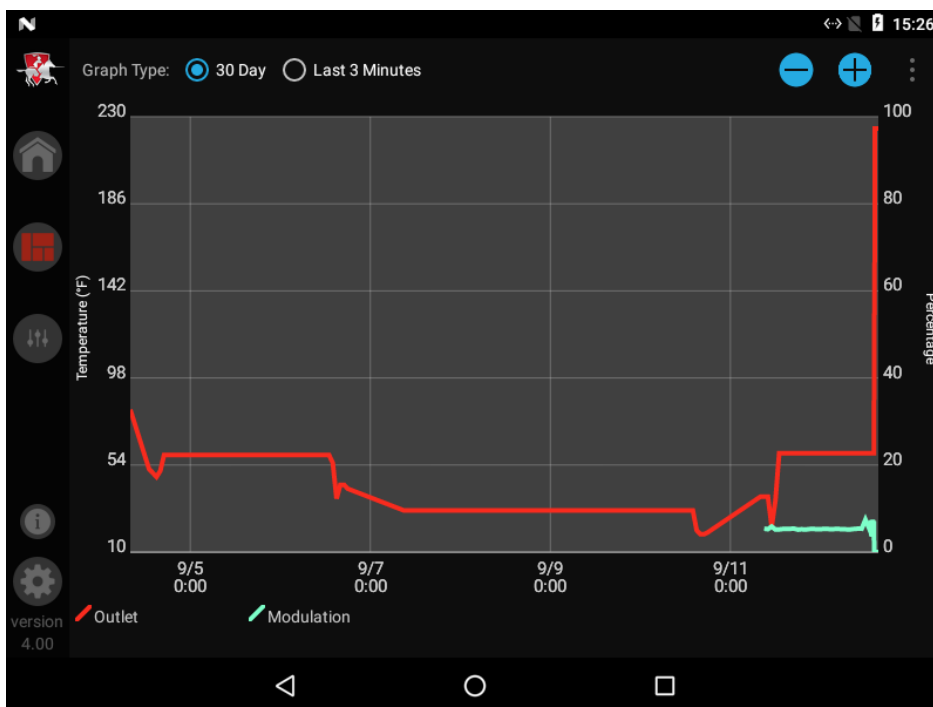

1 Service *(continued)*

History Screen

The History Screen shows the status of various counters and faults. Within the History Screen there are two separate sections, the “Lockout Blocking Fault” and “Runtime History”.

The left side of the screen reflects the “Lockout Blocking Fault” section which allows you to view the last 20 lockout/blocking faults. Succeeded by each fault is the date and time of when the fault occurred. A three (3) minute graph of sensor data before the fault can be viewed by selecting the VIEW button.

The “Runtime History” section includes the following information:

- Power hours – Shows the number of hours the control has been powered on since the last reset.
- Running hours – Shows the number of hours that the boiler has been firing since the last reset.
- Ignition attempts – Shows the number of times the control has attempted to ignite since the last reset.
- Successful Ignition attempts - Shows the number of times the control has successfully ignited since the last reset.
- Total Power hours – Show the total number of hours the control has been powered.
- Total Running hours – Show the total number of hours that the boiler has been firing.
- Total ignition attempts – Show the total number of times the control has attempted to ignite.
- Total Successful ignition attempts – Show the total number of times the control has successfully ignited.

The top right of this screen details the running hours based on 4 different running positions.

Figure 1-22 History Screen / Runtime History

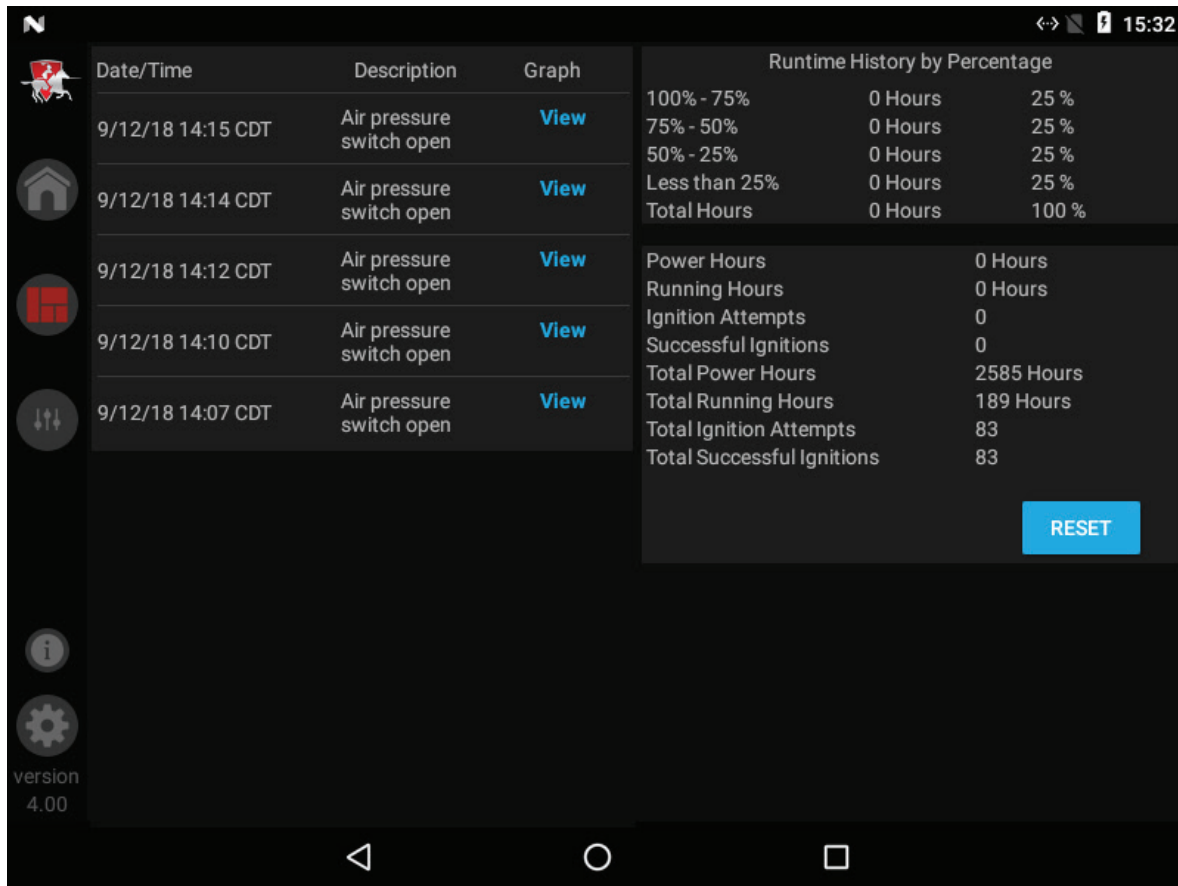

2 Maintenance

Maintenance and annual startup

Table 2A Service and Maintenance Schedules

Service technician (see the following pages for instructions)		Owner maintenance (see the Crest User's Information Manual for instructions)	
ANNUAL START-UP	General:	Daily	<ul style="list-style-type: none"> • Check boiler area • Check pressure/temperature gauge
	<ul style="list-style-type: none"> • Address reported problems, if any • Inspect interior; clean and vacuum if necessary; • Clean condensate trap and fill with fresh water • Check for leaks (water, gas, flue, condensate) • Verify flue and air lines in good condition and sealed tight • Check system water pressure/system piping/expansion tank • Check fill water meter • Test boiler water. When test indicates, clean system water with approved system restorer following manufacturer's information. • Check control settings • Check the ignition and both flame sense electrodes (sand off any deposits; clean and reposition) • Check wiring and connections • Perform start-up checkout and performance verification per Section 9 of the Crest Installation and Operation Manual. • Flame inspection (stable, uniform) • Check both flame signals (at least 10 microamps at high fire) • Test low water cutoff. 	Monthly	<ul style="list-style-type: none"> • Check vent piping • Check air piping • Check air and vent termination screens • Check relief valve • Check condensate drain system
	<p>If combustion or performance indicate need:</p> <ul style="list-style-type: none"> • Clean heat exchanger • Remove and clean burner using compressed air only • Clean the blower wheels 	Every 6 months	<ul style="list-style-type: none"> • Test low water cutoff • Reset button (low water cutoff) • Check boiler piping (gas and water) for leaks • Operate relief valve
		End of season months	<ul style="list-style-type: none"> • Shut boiler down (unless boiler used for domestic hot water)

2 Maintenance *(continued)*

⚠ WARNING Follow the service and maintenance procedures given throughout this manual and in component literature shipped with the boiler. Failure to perform the service and maintenance could result in damage to the boiler or system. Failure to follow the directions in this manual and component literature could result in severe personal injury, death, or substantial property damage.

⚠ WARNING The boiler should be inspected annually only by a qualified service technician. In addition, the maintenance and care of the boiler designated in Table 2A and explained on the following pages must be performed to assure maximum boiler efficiency and reliability. Failure to service and maintain the boiler and system could result in equipment failure.

⚠ WARNING Electrical shock hazard – Turn off power to the boiler before any service operation on the boiler except as noted otherwise in this instruction manual. Failure to turn off electrical power could result in electrical shock, causing severe personal injury or death.

Address reported problems

1. Inspect any problems reported by the owner and correct before proceeding.

Inspect boiler area

1. Verify that boiler area is free of any combustible materials, gasoline and other flammable vapors and liquids.
2. Verify that air intake area is free of any of the contaminants listed in Section 1 of this manual. If any of these are present in the boiler intake air vicinity, they must be removed. If they cannot be removed, reinstall the air and vent lines per this manual.

Inspect boiler interior

1. Remove the front access covers and inspect the interior of the boiler.
2. Vacuum any sediment from inside the boiler and components. Remove any obstructions.

Clean condensate trap

1. Inspect the condensate drain line, vent line, condensate PVC fittings, and condensate trap.

Flush condensate trap with water

1. Remove the four (4) screws securing the top cover to the condensate trap and remove the cover (FIG. 2-1).
2. Locate the plastic ball inside the float tube. Verify there is nothing under the ball causing it to not seat properly.
3. Fill with fresh water until the water begins to pour out of the drain.
4. Replace the top cover and the screws removed in Step 1.

Figure 2-1 Condensate Trap

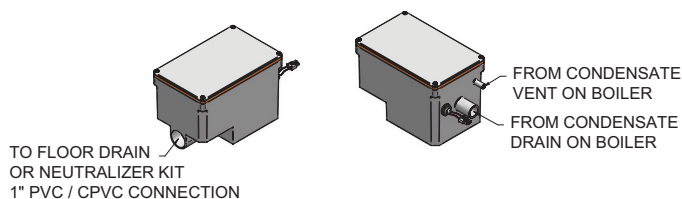

Check all piping for leaks

⚠ WARNING Eliminate all system or boiler leaks. Continual fresh makeup water will reduce boiler life. Minerals can build up, reducing heat transfer, overheating heat exchanger, and causing heat exchanger failure. Leaking water may also cause severe property damage.

1. Inspect all water and gas piping and verify to be leak free.
2. Look for signs of leaking lines and correct any problems found.
3. Check gas line using the procedure found in Section 6 - *Gas Connections of the Crest Installation and Operation Manual*.

Flue vent system and air piping

1. Visually inspect the entire flue gas venting system and air piping for blockage, deterioration or leakage. Repair any joints that show signs of leakage. Verify that air inlet pipe is connected and properly sealed.
2. Verify that boiler vent discharge and air intake are clean and free of obstructions.

⚠ WARNING Failure to inspect for the above conditions and have them repaired can result in severe personal injury or death.

Check water system

1. Verify all system components are correctly installed and operational.
2. Check the cold fill pressure for the system. Verify it is correct (must be a minimum of 12 psi (82.7 kPa)).
3. Watch the system pressure as the boiler heats up (during testing) to ensure pressure does not rise too high. Excessive pressure rise indicates expansion tank sizing or performance problem.
4. Inspect automatic air vents and air separators. Remove air vent caps and briefly press push valve to flush vent. Replace caps. Make sure vents do not leak. Replace any leaking vents.

2 Maintenance

Check expansion tank

1. Expansion tanks provide space for water to move in and out as the heating system water expands due to temperature increase or contracts as the water cools. Tanks may be open, closed or diaphragm or bladder type. See Section 5 - *Hydronic Piping* of the Crest Installation and Operation Manual for suggested best location of expansion tanks and air eliminators.

Check fill water meter

1. Check fill water meter for water usage. If the amount exceeds 5% of your system volume, you could have a leak. Have the system checked for leaks and fixed by a qualified service technician.

Test boiler water

1. Test boiler water. Reference the Crest Installation and Operation Manual for guidelines. When test indicates, clean system water with approved system restorer following the manufacturer's information.

Check boiler relief valve

1. Inspect the relief valve and lift the lever to verify flow. Before operating any relief valve, ensure that it is piped with its discharge in a safe area to avoid severe scald potential. Read Section 5 - *Hydronic Piping* of the Crest Installation and Operation Manual before proceeding further.

⚠ WARNING Safety relief valves should be re-inspected AT LEAST ONCE EVERY THREE YEARS, by a licensed plumbing contractor or authorized inspection agency, to ensure that the product has not been affected by corrosive water conditions and to ensure that the valve and discharge line have not been altered or tampered with illegally. Certain naturally occurring conditions may corrode the valve or its components over time, rendering the valve inoperative. Such conditions are not detectable unless the valve and its components are physically removed and inspected. This inspection must only be conducted by a plumbing contractor or authorized inspection agency – not by the owner. Failure to re-inspect the boiler relief valve as directed could result in unsafe pressure buildup, which can result in severe personal injury, death, or substantial property damage.

⚠ WARNING Following installation, the valve lever must be operated AT LEAST ONCE A YEAR to ensure that waterways are clear. Certain naturally occurring mineral deposits may adhere to the valve, rendering it inoperative. When manually operating the lever, water will discharge and precautions must be taken to avoid contact with hot water and to avoid water damage. Before operating lever, check to see that a discharge line is connected to this valve directing the flow of hot water from the valve to a proper place of disposal. Otherwise severe personal injury may result. If no water flows, valve is inoperative. Shut down the boiler until a new relief valve has been installed.

2. After following the above warning directions, if the relief valve weeps or will not seat properly, replace the relief valve. Ensure that the reason for relief valve weeping is the valve and not over-pressurization of the system due to expansion tank waterlogging or undersizing.

Inspect ignition and flame sense electrodes

1. Remove the ignition and both flame sense electrodes from the burner plate.
2. Remove any deposits accumulated on the ignition/flame sense electrodes using sandpaper. If the electrodes cannot be cleaned satisfactorily, replace with new ones.
3. Replace ignition/flame sense electrodes, making sure the gaskets are in good condition and correctly positioned.

Check ignition ground wiring

1. Inspect boiler ground wire from the heat exchanger access cover to ground terminal strip.
2. Verify all wiring is in good condition and securely attached.
3. Check ground continuity of wiring using continuity meter.
4. Replace ground wires if ground continuity is not satisfactory.

Check all boiler wiring

1. Inspect all boiler wiring, making sure wires are in good condition and securely attached.

Check control settings

1. Navigate to the Setup Screen and check all settings. See Section 1 of this manual. Adjust settings if necessary. See Section 1 of this manual for adjustment procedures.
2. Check settings of external limit controls (if any) and adjust if necessary.

Perform start-up and checks

1. Start boiler and perform checks and tests specified in Section 9 - *Start-up of the Crest Installation and Operation Manual*.
2. Verify cold fill pressure is correct and that operating pressure does not go too high.

Check burner flame

1. Inspect flame through observation windows.
2. If the flame is unsatisfactory at either high fire or low fire, remove and clean the burner. Clean the burner thoroughly using a vacuum cleaner or compressed air. Do not use compressed air to clean the burner if cleaning is performed inside a building.
 - Shut down the boiler:
 - Follow the “To Turn Off Gas to Appliance” instructions for the boiler in Section 9 - Startup of the Crest Installation and Operation Manual.
 - Do not drain the boiler unless it will be exposed to freezing temperatures. If using freeze prevention fluid in system, do not drain.
3. Allow time for the boiler to cool to room temperature if it has been firing.

2 Maintenance *(continued)*

4. Remove the top access panel(s) to gain access to the gas/air manifold assembly.
5. Remove the gas/air manifold burner access cover (FIG. 2-2).
6. Using care, remove the transition gas line from the gas/air manifold and orifice assembly.
7. Remove the orifice assembly from inside the burner.
8. Remove the nuts/washers holding the burner to the gas/air manifold assembly.
9. Remove the burner baffle and the burner from the gas/air manifold assembly.

NOTICE

The burner gasket, burner, burner baffle, and gas/air manifold access cover can only be installed in one orientation. All of these parts will have to be re-installed correctly. To ensure all of these parts are re-installed correctly, align the logo on top of the gas/air manifold cover with the logo on the gas/air manifold as shown in FIG. 2-2. Be certain to pay close attention to the bolt pattern when re-installing the above parts.

10. When replacing the burner, ensure gaskets are in good condition and positioned correctly (FIG. 2-2).
11. When securing the burner and manifold, be sure to tighten the nuts as follows:
 - a. Tighten the nuts in a star pattern sequence.
 - b. **0751-2001 Models:** Tighten the 1/4" nuts securing the burner to the cast manifold to 8 ft.-lbs.
2501-6001 Models: Tighten the 5/16" nuts securing the burner to the cast manifold to 15 ft.-lbs.
 - c. All models, check nuts securing the cast manifold and torque to 25 ft.-lbs, if necessary.
12. Re-install the orifice assembly and the transition gas line removed in Steps 6 and 7.
13. Re-install the gas/air manifold burner access cover. Tighten nuts to 8 ft.-lbs. using the star pattern sequence.
14. After firing the unit, re-tighten the nuts to the above torque specifications.

WARNING

Failure to follow the torquing specifications listed above could result in severe personal injury or death.

Figure 2-2 Burner Assembly

NOTE: Be sure to pay close attention to the Lochinvar logo. Align the logo with the Lochinvar logo on the gas/air manifold to ensure proper assembly. Pay close attention to the bolt pattern, as the gas/air manifold assembly can only be installed one way.

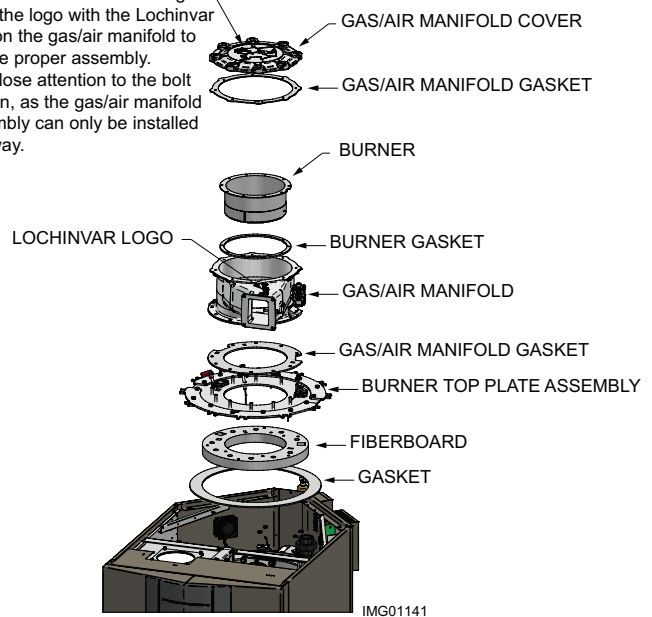

Check flame signal

1. At high fire of each combustion system, the flame signal shown on the display should be at least 10 microamps.
2. A lower flame signal may indicate a fouled or damaged flame sense electrode. If cleaning the flame sense electrodes does not improve, ground wiring is in good condition, and ground continuity is satisfactory, replace the flame sense electrode.
3. See Section 3 - *Troubleshooting* in this manual for other procedures to deal with low flame signal.

Review with owner

1. Review the Crest User's Information Manual with the owner.
2. Emphasize the need to perform the maintenance schedule specified in the Crest User's Information Manual (and in this manual as well).
3. Remind the owner of the need to call a licensed contractor should the boiler or system exhibit any unusual behavior.
4. Remind the owner to follow the proper shutdown procedure and to schedule an annual start-up at the beginning of the next heating season.

2 Maintenance

Cleaning boiler heat exchanger

1. Shut down boiler:
 - Follow the “To Turn Off Gas to Appliance” instructions for the boiler in Section 9 - Startup.
 - Do not drain the boiler unless it will be exposed to freezing temperatures. If using freeze prevention fluid in system, do not drain.
2. Allow time for the boiler to cool to room temperature if it has been firing.
3. Remove the top access panel to remove the gas/air manifold assembly.
4. Remove the nuts securing the burner to the burner mounting plate. Remove the burner (reference FIG. 2-2 and follow the steps in *Check Burner Flame* on pages 38-39).
5. Remove the nuts securing the burner mounting plate from the heat exchanger and set aside. Remove the entire burner mounting plate assembly.

⚠ WARNING The boiler contains ceramic fiber materials. Use care when handling these materials per instructions on this page. Failure to comply could result in severe personal injury.

6. Use a vacuum cleaner to remove any accumulation on the tube sheet surfaces. Do not use any solvent.
7. Brush the heat exchanger (tube sheet, combustion chamber walls, and tube entry) while dry using a nylon bristle brush. **Caution:** DO NOT use a metal brush. Re-vacuum the heat exchanger.
8. Finish cleaning using a clean cloth dampened with warm water.
9. Temporarily remove the condensate drain line from the condensate trap and route directly to a drain.
10. Rinse out debris with a low pressure water supply. The water will drain through the condensate connection.
11. Allow the heat exchanger to thoroughly dry.
12. Reconnect the condensate drain line to the condensate trap.
13. Close isolation valves on piping to isolate boiler from system. Attach a hose to the boiler drain and flush boiler thoroughly with clean water by using purging valves to allow water to flow through the water make-up line to the boiler.
14. When securing the burner, be sure to tighten the nuts as instructed in the “Check Burner Flame” section on pages 38 and 39 of this manual.
15. Replace the burner mounting plate assembly and gas/air manifold assembly. Ensure gaskets are in good condition and positioned properly. Restore boiler to operation.
16. Perform start-up and check-out procedures in the Check Flame and Combustion - Section 9 - Startup of the Crest Installation and Operation Manual.

Handling ceramic fiber materials REMOVAL OF COMBUSTION CHAMBER LINING



The combustion chamber insulation in this appliance contains ceramic fiber material. Ceramic fibers can be converted to cristobalite in very high temperature applications. The International Agency for Research on Cancer (IARC) has concluded, “Crystalline silica in the form of quartz or cristobalite from occupational sources is carcinogenic to humans (Group 1).” Normal operating temperatures in this appliance are below the level to convert ceramic fibers to cristobalite. Abnormal operating conditions would have to be created to convert the ceramic fibers in this appliance to cristobalite.

The ceramic fiber material used in this appliance is an irritant; when handling or replacing the ceramic materials it is advisable that the installer follow these safety guidelines.

- Avoid breathing dust and contact with skin and eyes.
 - Use NIOSH certified dust respirator (N95). This type of respirator is based on the OSHA requirements for cristobalite at the time this document was written. Other types of respirators may be needed depending on the job site conditions. Current NIOSH recommendations can be found on the NIOSH website at <http://www.cdc.gov/niosh/homepage.html>. NIOSH approved respirators, manufacturers, and phone numbers are also listed on this website.
 - Wear long-sleeved, loose fitting clothing, gloves, and eye protection.
- Apply enough water to the combustion chamber lining to prevent airborne dust.
- Remove the combustion chamber lining from the boiler and place it in a plastic bag for disposal.
- Wash potentially contaminated clothes separately from other clothing. Rinse clothes washer thoroughly.

NIOSH stated First Aid.

- Eye: Irrigate immediately.
- Breathing: Fresh air.

2 Maintenance *(continued)*

Test low water flow conditions

NOTICE

This test is to be carried out once the Crest boiler is completely piped in with adequate gas and water flow. Once the test is completed, ensure that the isolation valve is opened up to allow full water flow.

Test procedure

1. Place the unit into Service Mode. Navigate to the Setup Screen from the Home Screen by pressing the SETUP button along the left side of the screen. Enter the installer password.
2. Select the Service Maintenance Screen. The tabs will scroll (up and down) to reveal more options.
On the Service Maintenance Screen place heater into Service Mode by selecting the START button. In Service Mode the boiler will fire at ignition speed and will then modulate up to full fire.
3. Allow the unit to progress through its normal diagnostics and pre-purge programming.
4. Allow the unit to fire and operate until the temperatures stabilize. This occurs when the inlet and outlet temperatures are rising together and the Delta T (ΔT) is maintained.
5. When the unit stabilizes, begin to slowly shut off the isolation valve on the outlet piping of the boiler (see FIG. 2-3). This will begin to restrict the flow and simulate a low flow condition.
6. While slowly shutting off the isolation valve, refer to the Status Screen to watch the behavior of the boiler. This screen allows you to monitor the inlet temperature, outlet temperature, and ΔT .
7. When the ΔT reaches 70°F, the control will attempt to modulate the firing rate down to protect it from low flow conditions.
8. When the ΔT reaches 80°F, the control module will turn off the burner. If the control module shuts down, the test was successful.
9. Completely open the isolation valve on the outlet piping of the boiler.
10. Resume operation.

Figure 2-3 Adjust outlet isolation valve

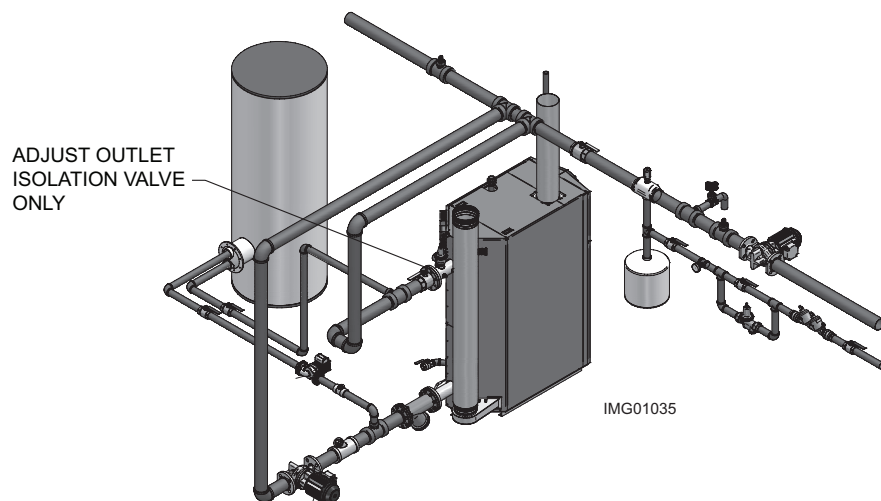

3 Troubleshooting

WARNING

Label all wires prior to disconnection when servicing controls. Wiring errors can cause improper and dangerous operation. Always disconnect power to the boiler before servicing. Failure to comply could result in severe personal injury, death, or substantial property damage.

WARNING

Never jumper (bypass) any device except for momentary testing as outlined in the Troubleshooting chart. Severe personal injury, death, or substantial property damage can result.

Before troubleshooting:

1. Have the following items:
 - a. Voltmeter that can check 120 vac, 24 vac, and 12 vdc.
 - b. Continuity checker.
 - c. Contact thermometer.
2. Check for 120 vac (minimum 102 vac to maximum 132 vac) to boiler.
3. Make sure thermostat is calling for heat and contacts are closed. Check for 24 vac between enable input and ground.
4. Make sure all external limit controls are installed and operating.

Check the following:

1. Wire connectors to control module are securely plugged in at the module and originating control.
2. Gas pressures:
 - Maximum: 14 inches w.c. (3.5 kPa) (natural and LP) with no flow (lockup) or with boiler on
 - Minimum: 4 inches w.c. (0.99 kPa) (NATURAL) or 8 inches w.c. (1.99 kPa) (PROPANE) with gas flowing (verify during boiler startup)

Check control module fuses

NOTICE

ALWAYS check control module fuses before replacing control module or any major components (blower, etc.). If one of these fuses is blown, it can prevent the control module or other components from operating.

1. Turn OFF the power to the boiler at the external line switch.
2. Remove the upper and lower doors.
3. Remove the four (4) screws securing the control panel cover to the unit to gain access to the control module.
4. Inspect fuses F2, F4, and F5, see FIG 3-1 below.

Figure 3-1 Control Module Fuses

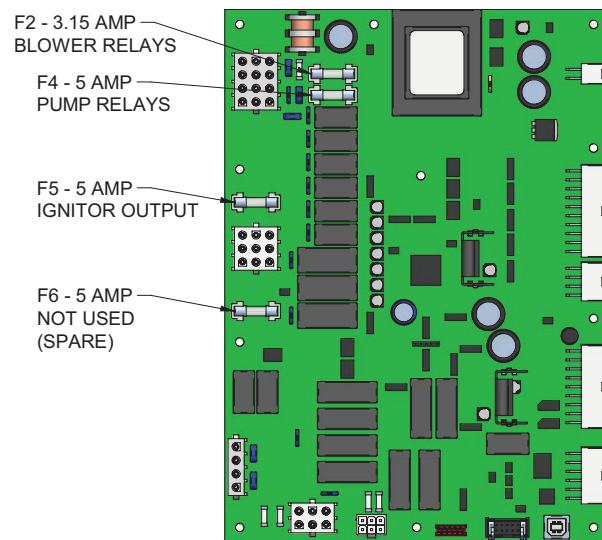

5. The boiler is shipped with four (4) spare fuses in a plastic bag located inside the control panel.
6. If necessary, replace open fuse (F2 is 3.15 amps, F4 and F5 are 5 amps each).

Note: Fuses F2, F4, and F5 are all slow blow fuses.

WARNING

Do not jumper fuse or replace with any fuse except as specified. Failure to comply could result in severe personal injury, death, or substantial property damage.

7. Re-install the control panel cover using the four (4) screws removed in Step 3. Re-install the upper and lower doors after fuse inspection.
8. Restore power to the boiler at the external line switch and verify boiler operation (Section 9 - Start-up in the Crest Installation and Operation Manual) after completing boiler service.

3 Troubleshooting *(continued)*

Table 3A Troubleshooting Chart - No Display

FAULT	CAUSE	CORRECTIVE ACTION
<p>No Display</p>	<ul style="list-style-type: none"> - No power supplied to the unit. - No LED's illuminated on the CON•X•US Interface control board. 	<ul style="list-style-type: none"> • Check external line switch, fuse, or breaker. • Check position of ON/OFF switch. Turn switch to the ON position. • Check 120 vac through the ON/OFF switch. • Check wiring harness connection between display board and main control board. Connect harness at both points.
	<ul style="list-style-type: none"> - Bad display, no LED's illuminated. 	<ul style="list-style-type: none"> • Check connection.
	<ul style="list-style-type: none"> - Bad display. 	<ul style="list-style-type: none"> • Replace the display.
<p>No Burner Operation</p>	<ul style="list-style-type: none"> - Main control board temperature set point satisfied. 	<ul style="list-style-type: none"> • Review temperature setting.
	<ul style="list-style-type: none"> - Remote thermostat satisfied. 	<ul style="list-style-type: none"> • Review remote thermostat setting.
	<ul style="list-style-type: none"> - Outside air temperature above Warm Weather Shutdown (WWSD) set point for main control board. 	<ul style="list-style-type: none"> • Check location of outside air sensor. Check resistance of outdoor air sensor and compare to Table 3C of this manual.
	<ul style="list-style-type: none"> - Unit locked out on fault. 	<ul style="list-style-type: none"> • Consult display for specific fault. Refer to fault descriptions in this manual for corrective actions.
<p>Unit Does Not Modulate Up to 100%</p>	<ul style="list-style-type: none"> - Ramp delay active. 	<ul style="list-style-type: none"> • Check ramp delay parameter settings. Optional PC software required.
		<ul style="list-style-type: none"> • Turn ramp delay feature off. See this manual for instructions on how to turn this feature off.
	<ul style="list-style-type: none"> - Boiler controlled by BMS. 	<ul style="list-style-type: none"> • Check BMS parameter settings.

3 Troubleshooting

Checking temperature sensors

The boiler temperature sensors (inlet water, outlet water, system water, flue, and outdoor air) are all resistance type devices. The following tables show the correct values for the sensors at various temperatures. Use an ohmmeter to read the resistance of the sensor at a known temperature. If the resistance of the sensor does not closely match its corresponding table, replace the sensor.

It is important to note that the flue and outlet water sensors each have two temperature sensing devices in one housing. These devices are designated as S1/S9 - outlet sensor and S3/S10 - flue sensor. Please reference the wiring diagram in the Crest Installation and Operation Manual for correct terminal location.

Table 3B - Inlet Water/System Sensor Resistance vs. Temperature

Temperature	Resistance	Temperature	Resistance
50	18,780	158	1,990
68	12,263	176	1,458
86	8,194	194	1,084
104	5,592	212	817
122	3,893		
140	2,760		

Table 3C - Outdoor Air Sensor Resistance vs. Temperature

Temperature	Resistance	Temperature	Resistance
-50	490,813	20	46,218
-40	336,606	30	34,558
-30	234,196	40	26,099
-20	165,180	50	19,900
10	118,018	60	15,311
0	85,362	70	11,883
10	62,465	80	9,299

Table 3D - Outlet Water Sensor Resistance vs. Temperature

Outlet	S1	R/Y		Outlet	S9	RW/Y	
Pre-Mix Air	S11	GY/Y					
Temperature	Resistance	Temperature	Resistance	Temperature	Resistance	Temperature	Resistance
50	19,553	158	2,004	50	40,030	158	3,478
68	12,690	176	1,464	68	25,030	176	2,492
86	8,406	194	1,084	86	16,090	194	1,816
104	5,715	212	816	104	10,610	212	1,344
122	3,958			122	7,166		
140	2,786			140	4,943		

Table 3E - Flue Sensor Resistance vs. Temperature

Flue	S3	GY/Y		Flue	S10	W/Y	
Temperature	Resistance	Temperature	Resistance	Temperature	Resistance	Temperature	Resistance
50	40,030	158	3,478	50	258,500	158	16,870
68	25,030	176	2,492	68	125,500	176	12,000
86	16,090	194	1,816	86	80,220	194	8,674
104	10,610	212	1,344	104	52,590	212	6,369
122	7,166			122	35,270		
140	4,943			140	24,160		

3 Troubleshooting *(continued)*

Table 3F Troubleshooting Chart - Noisy System

FAULT	CAUSE	CORRECTIVE ACTION
<p>Noisy Operation</p>	<ul style="list-style-type: none"> - Supply gas problem. Natural and LP gas pressures should be between 4 inches w.c. (1.0 kPa) and 14 inches w.c. (3.5 kPa). 	<ul style="list-style-type: none"> • Refer to Section 6 - Gas Connections of the Crest Installation and Operation Manual for detailed information concerning the gas supply.
	<ul style="list-style-type: none"> - Gas/air mixture problem. 	<ul style="list-style-type: none"> • Refer to the Gas Valve Adjustment Procedure in this manual for the proper gas valve setting. Verify that the vent/air intake lengths do not exceed the maximum listed in the General Venting section of the Crest Installation and Operation Manual.
	<ul style="list-style-type: none"> - Dirty/damaged burner. 	<ul style="list-style-type: none"> • Refer to this manual for the burner removal and inspection procedure. Clean or replace the burner as necessary.
	<ul style="list-style-type: none"> - Air in the piping system. 	<ul style="list-style-type: none"> • Properly purge all air from the piping system.
<p>No Pump Operation - Boiler Pump System Pump or HW Pump</p>	<ul style="list-style-type: none"> - Blown fuse. 	<ul style="list-style-type: none"> • Replace fuse F4 on the control board.
	<ul style="list-style-type: none"> - Faulty pump. 	<ul style="list-style-type: none"> • Replace pump.
	<ul style="list-style-type: none"> - Internal fault on control board. 	<ul style="list-style-type: none"> • Replace main control board.
	<ul style="list-style-type: none"> - Faulty pump relay. - Incorrect parameter setting. 	<ul style="list-style-type: none"> • Replace relay. • Reference the Boiler Pump Mode and System Pump Mode parameters in the Service section of this manual.
<p>No Blower Operation</p>	<ul style="list-style-type: none"> - Internal fault on control board. 	<ul style="list-style-type: none"> • Replace control board.
	<ul style="list-style-type: none"> - Faulty blower. 	<ul style="list-style-type: none"> • Replace blower.
	<ul style="list-style-type: none"> - Faulty blower relay. 	<ul style="list-style-type: none"> • Replace relay.
<p>Relief Valve Opening</p>	<ul style="list-style-type: none"> - System pressure exceeds relief valve setting. 	<ul style="list-style-type: none"> • Lower the system pressure below the rating of the supplied relief valve or replace the standard relief valve with a higher rated valve up to the maximum pressure of the heat exchanger 160 psi (40 kPa). • Improperly sized expansion tank.

3 Troubleshooting

Table 3G Troubleshooting Chart - Fault Messages Displayed on Boiler Interface

FAULT	DESCRIPTION	CORRECTIVE ACTION
<p>Gas Pressure SW Open (will require a manual reset once the condition has been corrected. Press the RESET button on the SMART TOUCH display to reset.)</p>	<p>Either the low gas pressure switch or the high gas pressure switches tripped.</p>	<ul style="list-style-type: none"> • Measure the supply gas pressure to determine cause of failure. Natural and LP gas pressures should be between 4 - 14 inches w.c. (1.0 - 3.5 kPa). • Refer to Section 6 - Gas Connections of the Crest Installation and Operation Manual for detailed information concerning the gas supply. • Correct the supply gas pressure if necessary.
<p>Low Water Cutoff Open (will require a manual reset once condition has been corrected. Press the RESET button on the SMART TOUCH display to reset.)</p>	<p>The low water cutoff is not making.</p>	<ul style="list-style-type: none"> • Reset the LWCO from the RESET button on the front control panel. • Verify system is full of water and all air has been purged from the system. • Check for loose or misplaced jumpers if flow switch or LWCO is not installed.
	<p>Blown fuse.</p>	<ul style="list-style-type: none"> • Replace fuse F2 on the control board.
<p>Blocked Drain SW Open (will require a manual reset once condition has been corrected. Press the RESET button on the SMART TOUCH display to reset.)</p>	<p>The blocked drain switch has detected excessive condensate build up inside the unit.</p>	<ul style="list-style-type: none"> • Check condensate tube from unit to floor drain for proper installation and obstructions. • Inspect condensate trap for blockage. Clean if necessary. • Check for loose wiring connection at wire harness plug. • Bad blocked drain switch. Replace switch.
<p>APS Open (will require a manual reset once the condition has been corrected. Press the RESET button on the SMART TOUCH display to reset.)</p>	<p>Blocked flue/inlet pressure switch contacts are open.</p>	<ul style="list-style-type: none"> • Check the wiring connections to switch. Wires should be connected to the common and normally closed terminals. • Vent/air intake lengths exceed the maximum allowed lengths. Refer to Section 2 - General Venting of the Crest Installation and Operation Manual for proper lengths. • Check for obstruction or blockage in the vent/air intake pipes or at terminations. • Check reference hose and tubing connected to the pressure switch for blockage or obstruction. • Inspect the burner. Reference this manual for removal and cleaning procedures. Replace if necessary. • Inspect the heat exchanger. Reference this manual for removal and cleaning procedures. Replace if necessary. • Faulty air pressure switch. Replace switch. • Verify combustion air blower is operating. Replace if necessary.

3 Troubleshooting *(continued)*

Table 3G (continued from previous page) *Troubleshooting Chart - Fault Messages Displayed on Boiler Interface*

FAULT	DESCRIPTION	CORRECTIVE ACTION
<p>Anti-cycling</p>	<p>The main control board has received a call for heat too quickly after the previous call for heat has ended.</p>	<ul style="list-style-type: none"> • The control board will release the call for heat after a set time period. • The control board will release the call for heat if the outlet temperature drops too quickly.
<p>Flame Failure 1 Ignition/ Flame Failure 2 Ignition <i>(will require a manual reset once the condition has been corrected. Press the RESET button on the SMART TOUCH display to reset.)</i></p>	<p>The unit has failed to prove main burner ignition. It will require a manual reset before attempting to fire again.</p>	<ul style="list-style-type: none"> • Inspect spark electrode and associated wiring for damage and connection. Reference this manual for removal and cleaning procedures. Replace if necessary. • Visually check for presence of a spark from the view port. • Check for proper electrical grounding of the unit. • Check incoming supply gas pressure. Natural and LP gas pressures should be between 4 - 14 inches w.c. (1.0 - 3.5 kPa). Refer to Section 6 - Gas Connections of the Crest Installation and Operation Manual for detailed information concerning the gas supply. • Verify that the plastic hose from gas valve 1 to the air inlet is connected and is not damaged. • Verify that the vent/air intake pipes are correctly installed and that there are no obstructions. • If 120 vac is present at the main control board, check the wiring between the main control board and the gas valve. Replace the wiring if necessary. Do not disconnect the wiring from the gas valve and attempt to measure voltage at that point. The main control board can detect if the gas valve is not connected and will display the Gas Valve / Connection fault. • If 120 vac is present, check the outlet of the valve to ensure the valve is flowing gas. With a manometer connected to the outlet tap of the gas valve, when the unit is in the prepurge period, there should be a negative pressure present. When the valve is energized a change in pressure should occur. If the pressure change does not occur, the gas valve is not opening. Replace the gas valve. • Inspect flame sensors and associated wiring. Reference this manual for removal and cleaning procedures. Replace if necessary. • Inspect the burner. Reference this manual for removal and cleaning procedures. Replace if necessary.

3 Troubleshooting

Table 3G (continued from previous page) *Troubleshooting Chart - Fault Messages Displayed on Boiler Interface*

FAULT	DESCRIPTION	CORRECTIVE ACTION
<p>Flame Failure 1 Running (will require a manual reset once the condition has been corrected. Press the RESET button on the SMART TOUCH display to reset.)</p>	<p>The unit was running and lost the flame signal.</p>	<ul style="list-style-type: none"> • Inspect flame rod 1 and associated wiring for damage and connection. Reference this manual for removal and cleaning procedures. Replace if necessary. • Check for proper electrical grounding of unit. • Check incoming supply gas pressure. Natural and L.P. gas pressures should be between 4 - 14 inches w.c. (1.0 - 3.5 kPa). Refer to Section 6 - Gas Connections of the Crest Installation and Operation Manual for detailed information concerning the gas supply. • Verify that the plastic hose from the gas valve to the air inlet is connected and is not damaged. • Verify that the vent/air intake pipes are installed correctly and there are no obstructions. • Inspect flame sensor and associated wiring. Reference this manual for removal and cleaning procedures. Replace if necessary. • Check combustion. • Inspect the burner. Reference this manual for removal and cleaning procedures. Replace if necessary.
<p>Flame Failure 2 Running (will require a manual reset once the condition has been corrected. Press the RESET button on the SMART TOUCH display to reset.)</p>	<p>The unit was running and lost the flame signal.</p>	<ul style="list-style-type: none"> • Inspect flame rod 2 and associated wiring for damage and connection. Reference this manual for removal and cleaning procedures. Replace if necessary. • Check for proper electrical grounding of unit. • Check incoming supply gas pressure. Natural and L.P. gas pressures should be between 4 - 14 inches w.c. (1.0 - 3.5 kPa). Refer to Section 6 - Gas Connections of the Crest Installation and Operation Manual for detailed information concerning the gas supply. • Verify that the plastic hose from the gas valve to the air inlet is connected and is not damaged. • Verify that the vent/air intake pipes are installed correctly and there are no obstructions. • Inspect flame sensor and associated wiring. Reference this manual for removal and cleaning procedures. Replace if necessary. • Check combustion. • Inspect the burner. Reference this manual for removal and cleaning procedures. Replace if necessary.
<p>Flame Failure 2 Transition (will require a manual reset once the condition has been corrected. Press the RESET button on the display to reset.)</p>	<p>The unit was running and lost the flame during a transition from one gas valve to the other.</p>	<ul style="list-style-type: none"> • Check the transition gas valve.

3 Troubleshooting *(continued)*

Table 3G (continued from previous page) *Troubleshooting Chart - Fault Messages Displayed on Boiler Interface*

FAULT	DESCRIPTION	CORRECTIVE ACTION
<p>Gas Valve / Relay Failure 1 (will require a manual reset once the condition has been corrected. Press the RESET button on the SMART TOUCH display to reset.)</p>	<p>The main control board did not detect gas valve 1.</p>	<ul style="list-style-type: none"> • Check wiring harness connection at the gas valve and at the main control board. • Replace the wire harness. • Replace the gas valve. • Replace the control board.
<p>Gas Valve / Relay Failure 2 (will require a manual reset once the condition has been corrected. Press the RESET button on the SMART TOUCH display to reset.)</p>	<p>The main control board did not detect gas valve 2.</p>	<ul style="list-style-type: none"> • Check wiring harness connection at the gas valve and at the main control board. • Replace the wire harness. • Replace the gas valve. • Replace the control board.
<p>Auto Reset High Limit</p>	<p>The outlet water temperature has exceeded the setting of the automatic reset high limit.</p>	<ul style="list-style-type: none"> • Verify that the system is full of water and that all air has been properly purged from the system. • Verify that the boiler is piped properly into the heating system. Refer to Section 5 - Hydronic Piping of the Crest Installation and Operation Manual for the proper piping methods for the Crest boiler. • Check 120 vac to boiler pump motor on a call for heat. If voltage is not present, check wiring back to the main control board. • Check the ARHL set point. • If 120 vac is present on a call for heat and the boiler pump is not operating, replace the pump. • If the system pump is a variable speed pump, ensure that the system flow is not less than the boiler flow. • If operating on something other than an outlet sensor, check temperature setting of the main control board. • If the optional manual reset high limit has tripped, check setting of the device. • Check resistance of water sensors and compare to Table 3B of this manual. Replace sensor if necessary. • Replace the main control board.

3 Troubleshooting

Table 3G (continued from previous page) Troubleshooting Chart - Fault Messages Displayed on Boiler Interface

FAULT	DESCRIPTION	CORRECTIVE ACTION
<p>Manual Reset High Limit Open (will require a manual reset once the condition has been corrected. Press the RESET button on the SMART TOUCH display to reset.)</p>	<p>The outlet water temperature has exceeded the setting of the high limit.</p>	<ul style="list-style-type: none"> • Verify that the system is full of water and that all air has been properly purged from the system. • Verify that the boiler is piped properly into the heating system. Refer to Section 5 - Hydronic Piping of the Crest Installation and Operation Manual for the proper piping methods for the Crest boiler. • Check voltage to boiler pump motor on a call for heat. If voltage is not present, check wiring back to the main control board. • Replace the pump relay if necessary. • If 120 vac is present on a call for heat and the boiler pump is not operating, replace the pump. • If the system pump is a variable speed pump, ensure that the system flow is not less than the boiler flow. • If operating on either an inlet or system supply sensor, check temperature setting of the main control board. • If the high limit has tripped, check setting of the device and the MRHL set point. • Check resistance of water sensors and compare to Table 3B of this manual. Replace sensor if necessary. • Replace high limit (if equipped). • Replace main control board.
<p>Fan Speed Low (will require a manual reset once the condition has been corrected. Press the RESET button on the SMART TOUCH display to reset.)</p>	<p>The actual fan RPM is 30% lower than what is being called for.</p>	<ul style="list-style-type: none"> • Vent/air intake lengths exceed the maximum allowed lengths. Refer to Section 2 - General Venting of the Crest Installation and Operation Manual for proper lengths. • Check for obstruction or blockage in the vent/air intake pipes or at terminations. • Check the wiring connections at the fan and at the main control board. • Replace the fan.
	<p>Blown fuse.</p>	<ul style="list-style-type: none"> • Replace fuse F2 on the control board.

3 Troubleshooting *(continued)*

Table 3G (continued from previous page) *Troubleshooting Chart - Fault Messages Displayed on Boiler Interface*

FAULT	DESCRIPTION	CORRECTIVE ACTION
<p>Fan Speed High (will require a manual reset once the condition has been corrected. Press the RESET button on the SMART TOUCH display to reset.)</p>	<p>The actual fan RPM is 30% higher than what is being called for.</p>	<ul style="list-style-type: none"> • Vent/air intake lengths exceed the maximum allowed lengths. Refer to Section 2 - General Venting of the Crest Installation and Operation Manual for proper lengths. • Check for obstruction or blockage in the vent/air intake pipes or at terminations. • Check the wiring connections at the fan and at the main control board. • Replace the fan.
<p>Louver Proving Sw Open</p>	<p>An optional remote proving switch is not making.</p>	<ul style="list-style-type: none"> • Check function of remote devices. • Check for loose or misplaced jumper if proving switch is not installed.
<p>Flue Temp High</p>	<p>The stack temperature has exceeded the set parameters for the boiler.</p>	<ul style="list-style-type: none"> • Inspect the heat exchanger. Reference this manual for the procedure on how to clean the flue side of the heat exchanger. • Inspect the flue sensor and associated wiring. Measure the resistance of the flue sensor and compare to Table 3E of this manual. Replace the sensor if necessary. • Verify that the vent/air intake pipes are properly installed and that there are no obstructions.
<p>Delta T High</p>	<p>The temperature rise across the heat exchanger has exceeded the set parameters for the boiler.</p>	<ul style="list-style-type: none"> • Verify that the system is full of water and that all air has been properly purged from the system. • Verify that the boiler is piped properly into the heating system. Refer to Section 5 - Hydronic Piping of the Crest Installation and Operation Manual for the proper piping methods for the Crest boiler. • Check for 120 vac to the boiler pump motor on a call for heat. If voltage is not present, check the wiring back to the main control board. Replace the main control board if necessary. • If 120 vac is present on a call for heat and the boiler pump is not operating, replace the pump. • Verify that the boiler pump is set to the proper speed or that the pump is the proper size. Reference Section 5 - Hydronic Piping of the Crest Installation and Operation Manual for boiler pump specifications. • Inspect the inlet and outlet sensors and associated wiring. Measure the resistance of the sensors and compare to the tables in this manual.

3 Troubleshooting

Table 3G (continued from previous page) *Troubleshooting Chart - Fault Messages Displayed on Boiler Interface*

FAULT	DESCRIPTION	CORRECTIVE ACTION
<p>Outlet Temp High</p>	<p>Outlet water temperature has exceeded the maximum outlet water temperature.</p>	<ul style="list-style-type: none"> • Verify that the system is full of water and that all air has been properly purged from the system. • Verify that the boiler is piped properly into the heating system. Refer to Section 5 - Hydronic Piping of the Crest Installation and Operation Manual for the proper piping methods for the Crest boiler. • Check for 120 vac to the boiler pump motor on a call for heat. If voltage is not present, check wiring back to the main control board. Replace the main control board if necessary. • If 120 vac is present on a call for heat and the boiler pump is not operating, replace the pump. • Verify that the boiler pump is set to the proper speed or that the boiler pump is the proper size. Reference Section 5 - Hydronic Piping of the Crest Boiler Installation and Operation Manual for boiler pump specifications. • Inspect the outlet sensors and associated wiring. Measure the resistance of the sensors and compare to the tables in of this manual.
<p>Parameter Programming Complete (will require a manual reset once the condition has been corrected. Press the RESET button on the SMART TOUCH display to reset.)</p>	<p>After downloading parameters from a laptop, the main control board must be reset.</p>	<ul style="list-style-type: none"> • Press the RESET button on the SMART TOUCH display panel.
<p>Sensor Open (will require a manual reset once the condition has been corrected. Press the RESET button on the display to reset.)</p>	<p>Either the inlet water or outlet water temperature sensor has been disconnected.</p>	<ul style="list-style-type: none"> • Check the sensors and their associated wiring. Repair or replace the sensor or wiring if damaged. • Measure the resistance of the sensors and compare the resistance to the tables in this manual. • Replace the sensor if necessary.
<p>Sensor Shorted (will require a manual reset once the condition has been corrected. Press the RESET button on the display to reset.)</p>	<p>Either the inlet water or outlet water temperature sensor has been shorted.</p>	<ul style="list-style-type: none"> • Check the sensors and their associated wiring. Repair or replace the sensor or wiring if damaged. • Measure the resistance of the sensors and compare the resistance to the tables in this manual. • Replace the sensor if necessary.
<p>Flue Sensor Open (will require a manual reset once the condition has been corrected. Press the RESET button on the display to reset.)</p>	<p>The flue sensor has been disconnected or removed from the flue.</p>	<ul style="list-style-type: none"> • Check the sensor and its associated wiring. Repair or replace the sensor or wiring if damaged. • Measure the resistance of the sensors and compare the resistance to the tables in this manual. • Replace the sensor in flue. • Replace the sensor if necessary.

3 Troubleshooting *(continued)*

Table 3G (continued from previous page) *Troubleshooting Chart - Fault Messages Displayed on Boiler Interface*

FAULT	DESCRIPTION	CORRECTIVE ACTION
<p>Flue Sensor Shorted (will require a manual reset once the condition has been corrected. Press the RESET button on the display to reset.)</p>	<p>The flue sensor has been shorted.</p>	<ul style="list-style-type: none"> • Check the sensor and its associated wiring. Repair or replace the sensor or wiring if damaged. • Measure the resistance of the sensors and compare the resistance to the tables in this manual. • Replace the sensor if necessary.
<p>Too Many Resets - Try Later</p>	<p>Too many manual resets have occurred during a 15 minute period.</p>	<ul style="list-style-type: none"> • Wait 15 minutes and try again. • Turn power off to unit, wait 30 seconds and then turn power back on.
<p>Internal Fault</p>	<p>The main control board has detected an internal fault.</p>	<ul style="list-style-type: none"> • Replace the main control board.
<p>Flue Temp Shutdown</p>	<p>The stack temperature has exceeded the set parameters for the boiler.</p>	<ul style="list-style-type: none"> • Inspect the heat exchanger. Reference this manual for the procedure on how to clean the flue side of the heat exchanger. • Inspect the flue sensor and associated wiring. Measure the resistance of the flue sensor and compare to Table 3E of this manual. Replace the sensor if necessary. • Verify that the vent/air intake pipes are properly installed and that there are no obstructions. • Replace the main control board.
<p>Delta T Shutdown</p>	<p>The temperature rise across the heat exchanger has exceeded the set parameters for the boiler.</p>	<ul style="list-style-type: none"> • Verify that the system is full of water and that all air has been properly purged from the system. • Verify that the boiler is piped properly into the heating system. Refer to Section 5 - Hydronic Piping of the Crest Installation and Operation Manual for the proper piping methods for the Crest boiler. • Check for voltage to the boiler pump motor on a call for heat. If voltage is not present, check the wiring back to the pump relay. Replace the pump relay if necessary. • If 120 VAC is present on a call for heat and the boiler pump is not operating, replace the pump. • Verify that the boiler pump is set to the proper speed or that the pump is the proper size. Reference Section 5 - Hydronic Piping of the Crest Installation and Operation Manual for boiler pump specifications.

3 Troubleshooting

Table 3G (continued from previous page) *Troubleshooting Chart - Fault Messages Displayed on Boiler Interface*

FAULT	DESCRIPTION	CORRECTIVE ACTION
Outlet Temp Shutdown	Outlet water temperature has exceeded the maximum outlet water temperature.	<ul style="list-style-type: none"> • Verify that the system is full of water and that all air has been properly purged from the system. • Verify that the boiler is piped properly into the heating system. Refer to Section 5 - Hydronic Piping of the Crest Installation and Operation Manual for the proper piping methods for the Crest boiler. • Check for voltage to the boiler pump motor on a call for heat. If voltage is not present, check wiring back to the pump relay. Replace the pump relay if necessary. • If 120 VAC is present on a call for heat and the boiler pump is not operating, replace the pump.
Writing/ Programming EEPROM Error	The main control board has detected an internal fault.	<ul style="list-style-type: none"> • Turn power OFF and back ON. • Replace the main control board.
CRC Parameter Error	The main control board has detected an internal fault.	<ul style="list-style-type: none"> • Turn power OFF and back ON. • Replace the main control board.
Wrong Error Code	The main control board has detected an internal fault.	<ul style="list-style-type: none"> • Press the RESET button on the SMART TOUCH display panel.
Flame Sense Out of Sequence 1 (will require a manual reset once the condition has been corrected. Press the RESET button on the display to reset.)	Flame Sensor 1 senses a flame while gas valve 1 and gas valve 2 are turned off.	<ul style="list-style-type: none"> • Clean Flame Sensor 1. • Replace control board.
Flame Sense Out of Sequence 2 (will require a manual reset once the condition has been corrected. Press the RESET button on the display to reset.)	Flame Sensor 2 senses a flame while all gas valves are turned off.	<ul style="list-style-type: none"> • Clean Flame Sensor 2. • Replace control board.
Flue Damper Switch Open	The flue damper proving switch is not closed when the flue damper is energized.	<ul style="list-style-type: none"> • Check that the flue damper is connected to the 3-pin connector on the rear of the boiler. • Check the wiring between the flue damper connector and the control board. • Check for 24VAC from the output of the flue damper transformer when the fan is running. • Check for 120VAC from the output of the flue damper transformer when the fan is running. • Check the wiring between the flue damper transformer and the control board. • Check fuse F4 on the control board. • Replace the flue damper. • Replace the control board.

3 Troubleshooting *(continued)*

Table 3G (continued from previous page) *Troubleshooting Chart - Fault Messages Displayed on Boiler Interface*

FAULT	DESCRIPTION	CORRECTIVE ACTION
<p>IO Expander Out Error</p>	<p>The control board detected an internal fault.</p>	<ul style="list-style-type: none"> • Turn the power OFF. Wait 15 seconds, then turn the power back ON. • Replace the control board.
<p>Wrong Personality Plug</p>	<p>The personality plug does not match the personality plug value stored in memory.</p>	<ul style="list-style-type: none"> • Remove the lower front jacket and compare the personality plug value shown on the display with the value on the personality plug label. If the two values match, accept the new personality plug value. • Check the connections at the personality plug connector.
<p>Air Metering Valve Stuck Closed (will require a manual reset once the condition has been corrected. Press the RESET button on the display to reset.)</p>	<p>The air metering valve did not open when needed.</p>	<ul style="list-style-type: none"> • Check the voltage at connector X6, pin 13 at the start of PrePurge. If not 24VAC, replace the control board. • Check the wiring between the control board and the air metering valve. • Replace the air metering valve. • Replace the control board. • Check the slide switch on the inside of the air metering valve actuator.
<p>Air Metering Valve Stuck Open (will require a manual reset once the condition has been corrected. Press the RESET button on the display to reset.)</p>	<p>The air metering valve did not close when needed.</p>	<ul style="list-style-type: none"> • Check the voltage at connector X6 pin 13 during the last part of PrePurge. If 24VAC, replace the control board. • Check the wiring between the control board and the air metering valve. • Replace the control board.
<p>Failure ADC Controller (will require a manual reset once the condition has been corrected. Press the RESET button on the display to reset.)</p>	<p>A problem was detected with measuring one or more temperature sensors.</p>	<ul style="list-style-type: none"> • Check all connections between the temperature sensors and the control board. Make sure all connections are dry and secure. • Connect a PC to the control board and open the Status window. Look for temperature readings that are jumping by more than 1°F. • Check the resistance of all sensors (see this manual). • Replace the control board.
	<p>The control board has detected an internal fault.</p>	<ul style="list-style-type: none"> • Turn the power OFF. Wait 15 seconds, then turn the power back ON. • Replace the control board.

3 Troubleshooting

Table 3G (continued from previous page) *Troubleshooting Chart - Fault Messages Displayed on Boiler Interface*

FAULT	DESCRIPTION	CORRECTIVE ACTION
<p>Outlet Sensor Differential (will require a manual reset once the condition has been corrected. Press the RESET button on the display to reset.)</p>	<p>The readings from the two outlet temperature sensors are too far apart.</p>	<ul style="list-style-type: none"> • Check all connections between the outlet temperature sensors and the control board. Make sure all connections are dry and secure. • Check the resistance of the two outlet sensors (see this manual). • Replace the control board.
<p>Flue Sensor Differential (will require a manual reset once the condition has been corrected. Press the RESET button on the display to reset.)</p>	<p>The readings from the two flue temperature sensors are too far apart.</p>	<ul style="list-style-type: none"> • Check all connections between the flue temperature sensors and the control board. Make sure all connections are dry and secure. • Check the resistance of the two flue sensors (see this manual). • Replace the control board.

3 Troubleshooting *(continued)*

Combustion Analysis

NOTICE

For dual fuel models, reference the Crest Dual Fuel Supplemental Manual.

1. Turn the main power off to the boiler by placing the "On/Off" switch in the OFF position.
2. Remove the fitting from the flue collector. **Note:** Combustion measurements will be made at this point.
3. Insert the probe from a combustion analyzer into the hole left by the removal of the fitting.
4. Turn the main power on to the boiler by placing the "On/Off" switch in the ON position.
5. Navigate to the Setup Screen from the Home Screen by pressing the SETUP button along the left side of the screen. Enter the installer password.
6. Select the Service Maintenance Screen. The tabs will scroll (up and down) to reveal more options.

On the Service Maintenance Screen place heater into Service Mode by selecting the START button, then selecting **Set Gas Valve 1 - High** (FIG. 3-2).

7. Once the boiler has modulated up to rate, measure the combustion. The values should be in the range listed in Table 3H (this page). CO levels should be less than 200 ppm for a properly installed unit. If the combustion is not within range reference the Troubleshooting Chart for possible causes and corrective actions.

8. Once the heater analysis is complete, test the safety shutoff device by turning the manual shutoff valve to the OFF position and ensuring the heater shuts down and registers an alarm. Open the manual shutoff valve and reset the control.
9. Turn the main power off to the boiler and replace the fitting into the flue pipe connection.
10. Ensure the boiler is placed back into normal operation.

WARNING

You must replace the fitting to prevent flue gas spillage into the room. Failure to comply could result in severe personal injury, death, or substantial property damage.

Table 3H Flue Products

Flue Products	Natural Gas			
	751-2001		2501-6001	
Units	CO ₂ (%)	O ₂ (%)	CO ₂ (%)	O ₂ (%)
Gas Valve				
Valve 1 High	9.2	4.6	9.2	4.6
Valve 1 Low	9.0	4.9	8.5	5.7
Valve 2 High	9.3	4.4	9.5	4.2
Valve 2 Low	8.7	5.5	8.8	5.4
Propane				
Units	751-2001		2501-6001	
Gas Valve	CO ₂ (%)	O ₂ (%)	CO ₂ (%)	O ₂ (%)
Valve 1 High	11.0	4.1	11	4.1
Valve 1 Low	10.0	5.6	9.9	5.7
Valve 2 High	11.1	4.0	11.1	4
Valve 2 Low	10.7	4.6	10.1	5.5

All set points should be within +/- 0.2%

Figure 3-2 Service Screen

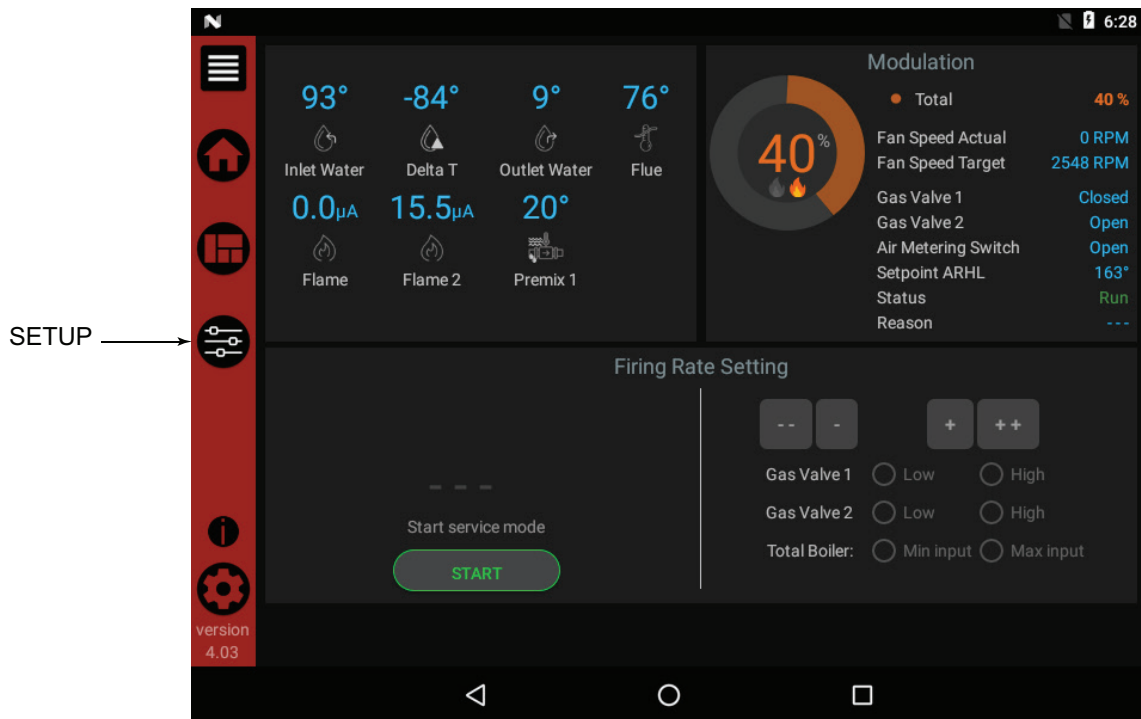

3 Troubleshooting

Table 3I Troubleshooting Chart - Combustion Levels

POSSIBLE CAUSE	CORRECTIVE ACTION
Vent/Air Intake Length or Obstruction	<ul style="list-style-type: none"> • Refer to Section 2 - General Venting of the Crest Installation and Operation Manual for the proper venting and air intake methods for the Crest boiler. • Check for obstructions at the vent/air intake terminals.
Gas Supply Pressure	<ul style="list-style-type: none"> • Refer to Section 6 - Gas Connections of the Crest Installation and Operation Manual for the proper gas supply for the Crest boiler.
Dirty/Damaged Burner	<ul style="list-style-type: none"> • Refer to this manual for burner removal and cleaning procedures. • Replace burner if necessary.
Gas Valve Adjustment	<ul style="list-style-type: none"> • Refer to this manual for the gas valve adjustment procedure.

3 Troubleshooting *(continued)*

Gas valve adjustment procedure

CAUTION Under normal operating conditions this valve should not need adjusting.

Locate the throttle adjustment screw on the gas valve (see FIG.'s 3-3 thru 3-5). Using a screwdriver, turn the screw a 1/4 turn **counterclockwise** to increase CO₂ levels or a 1/4 turn **clockwise** to decrease CO₂ levels. After one adjustment on the valve, follow the Combustion Analysis Procedure on page 57 of this manual to measure the combustion.

If combustion is still not within the specified range, repeat the procedure. This procedure **SHOULD NOT** be performed more than four (4) times. If after four (4) adjustments and the combustion is still not within the specified range, revisit the possible causes in Table 3I on page 58 or replace the gas valve.

Figure 3-3 Gas Valve Adjustment - Models 751 - 2.0 Series 100 & 101

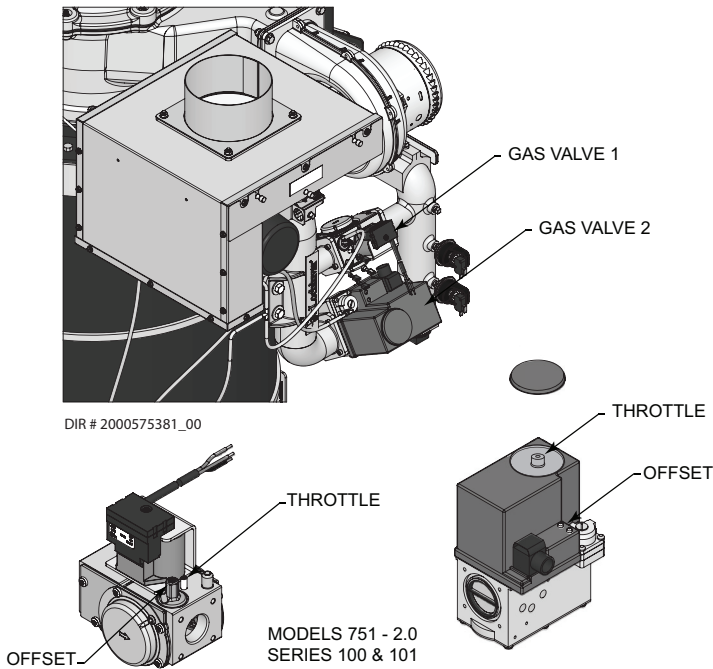

Figure 3-4 Gas Valve Adjustment - Models 751 - 2.0 Series 110 & 111

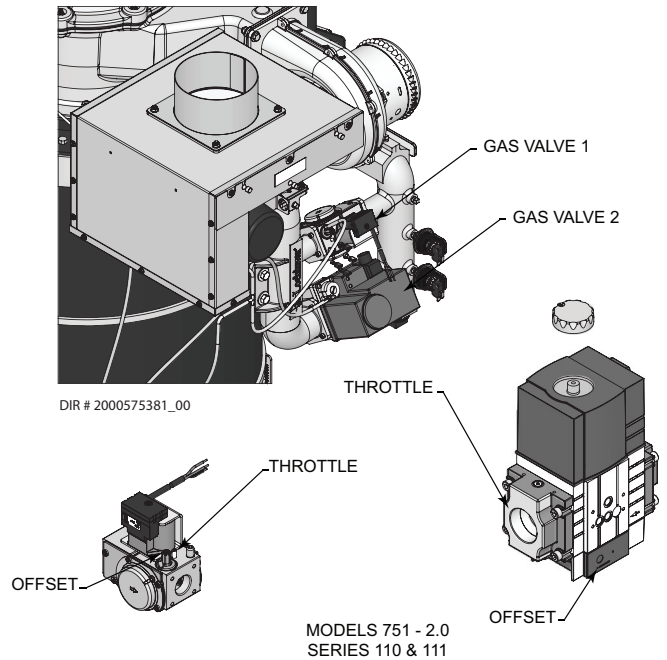
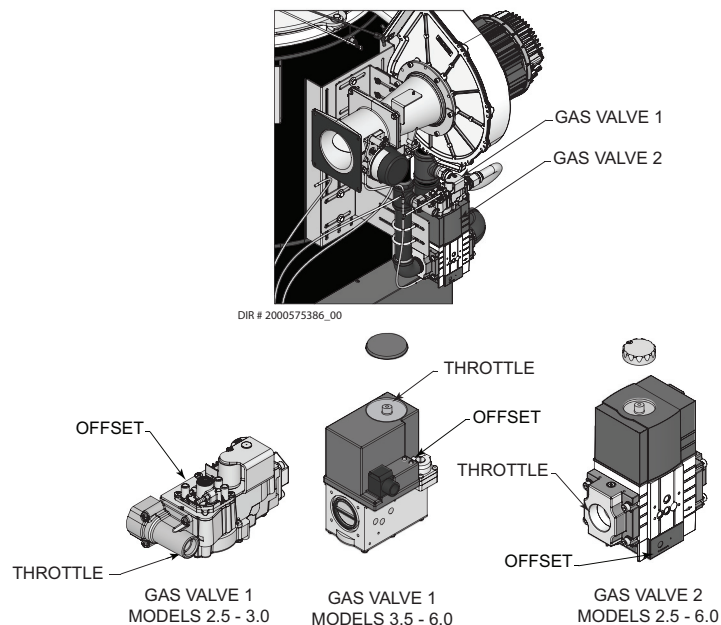

Figure 3-5 Gas Valve Adjustment - Models 2.5 - 6.0



Revision Notes: Revision A (ECO #C17106) initial release.

Revision B (ECO C17419) reflects the addition of the large Crest models (1501 - 2001).

Revision C (Change #500001029) reflects the addition of the Crest CON•X•US Interface.

Revision D (PCP# 3000002050 / CN# 500002334) reflects updates made to the BMS and BAS instructions on pages 21-22.

Revision E (PCP# 3000002544 / CN# 500002701) reflects updates made to ΔT Set Point under Pumps on page 27, step 10 under Sequence of Operation on page 11, and the second paragraph on page 44.

Revision F (PCP# 3000002426 / CN# 500003006) reflects an update to the Crest home screen image on the manual cover.

Revision G (PCP# 3000004438 / CN# 500005574) reflects an update to table 3H on page 57.

Revision H (PCP# 3000007442 / CN# 500007741) reflects new fan troubleshooting information in Table 3F on page 45.

Revision J (PCP# 3000009267 / CN# 500009031) reflects an update to the water chemistry information on pages 36 and 38.

Revision K (PCP #3000024064 / CN #500014120) reflects an update to the burner maintenance information on page 39.

Revision L (PCP# 3000025102 / CN# 500014948) reflects the addition of Models 2501 - 6001.

Revision M (PCP #3000027116 / CN #500016865) reflects the addition of the Series 110 and 111 models and Figure 3-4 on page 59.

Revision N (PCP #3000028279 / CN #500017755) reflects an update to the user interface screens.

Revision P (PCP #3000033820 / CN #500022587) reflects an update to Figures 3-3 & 3-4 on page 59, along with updates made to the user interface descriptions on pages 30 and 31.

Revision R (PCP #3000040404 / CN #500028531) reflects an update to the propane minimum inlet gas pressure.

Revision T (PCP #3000041734 / CN #500029765) reflects additional information added to the cascade setup / alternate leader information.

Revision U (PCP #30000048490 / CN #500035753) reflects changes to Figures 3-4 & 3-5 on page 59.