



LHSC 546 Vance Home Renovation  
(19-LHSC006)  
Issue Date: May 17, 2019

---

---

ADDENDUM #1

Issued: May 31, 2019

---

---

**NOTICE TO PROPOSERS:**

- A. This Addendum shall be considered part of the Contract Documents for the above mentioned project as though it had been issued at the same time and shall be incorporated integrally therewith. Where provisions of the following supplementary data differ from those of the original Contract Documents, this Addendum shall govern and take precedence.
- B. Offerors are hereby notified that they shall make any necessary adjustment in their estimates on account of this Addendum. It will be construed that each Bidder's documentation is submitted with full knowledge of all modifications and supplemental data specified herein.

---

Addendum #1

1. Attached are casework drawings for the Kitchen and baths.
2. Attached is the pre-bid walk-thru sign-in sheet.

(End of Addendum #1)

#####

Solicitation Scope Inquiries:

Craig Bartley

E-Mail:

[cbartley@lucasmha.org](mailto:cbartley@lucasmha.org)



This Addendum shall be considered part of the above referenced IFB as though it had been issued at the same time and shall be incorporated integrally therewith. Where provisions of the following supplementary data differ from those of the original Contract Documents, this Addendum shall govern and take precedence.

(1) GAUGE LEVEL OF INTEREST: So that we can gauge the level of interest in this IFB, if you have not previously done so, please advise us as to whether or not you anticipate delivering to us a quotation submittal in response to this solicitation (e.g. "Will Submit" or "No Bid").

**Will Submit** \_\_\_\_\_ **No Bid** \_\_\_\_\_

Thank you for your interest in doing business with LMHA and we look forward to receiving a submission from your firm.

Sherry Tobin, Manager, Procurement & Contracts  
On behalf of Lucas Housing Services Corporation

\*\*\*\*\*

ACKNOWLEDGED BY:

\_\_\_\_\_

Signature

Date

Printed Name

Company

\_\_\_\_\_  
E-mail address

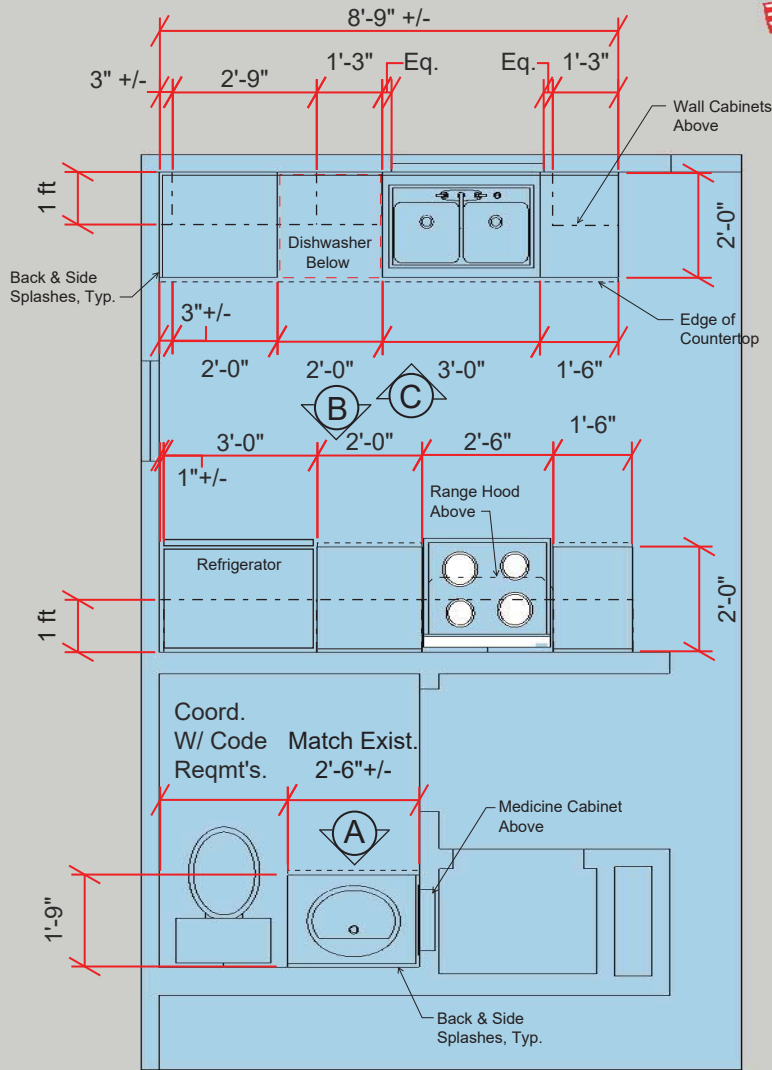

ENLARGED KITCHEN & 1st FLR. BATH PLANS

N.T.S.

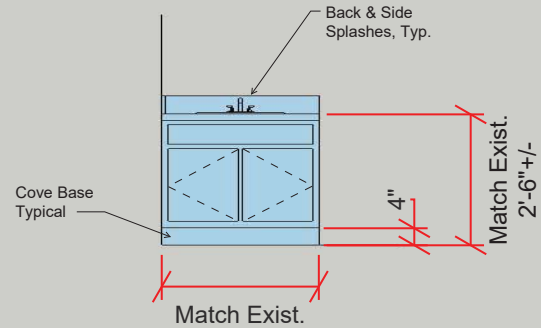

VANITY ELEV.

N.T.S.

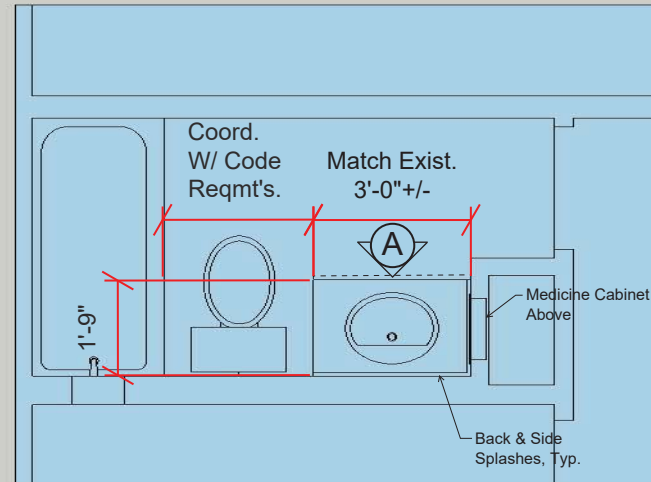

ENLARGED 2nd FLR. BATH PLAN

N.T.S.

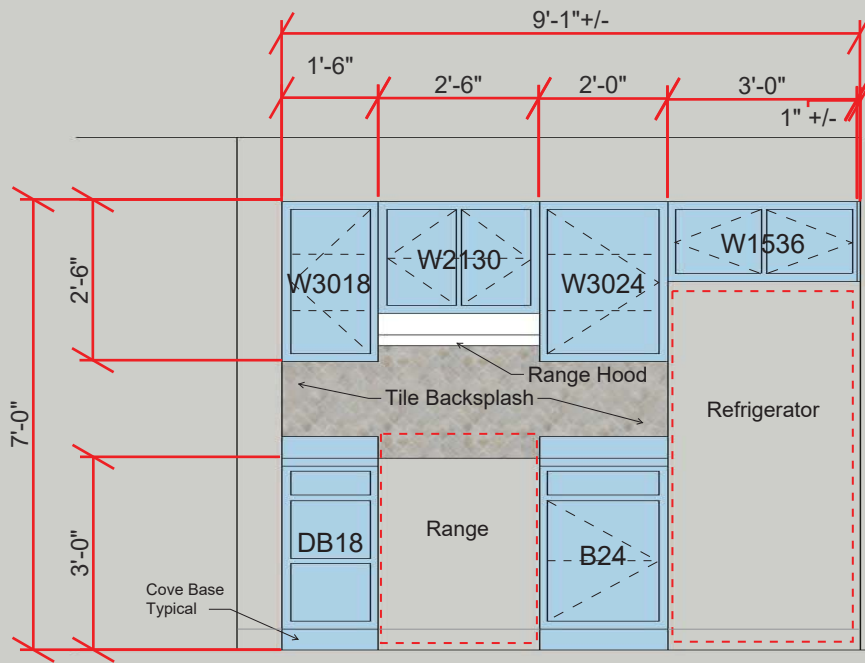

### KITCHEN ELEVATION

N.T.S.

(B)

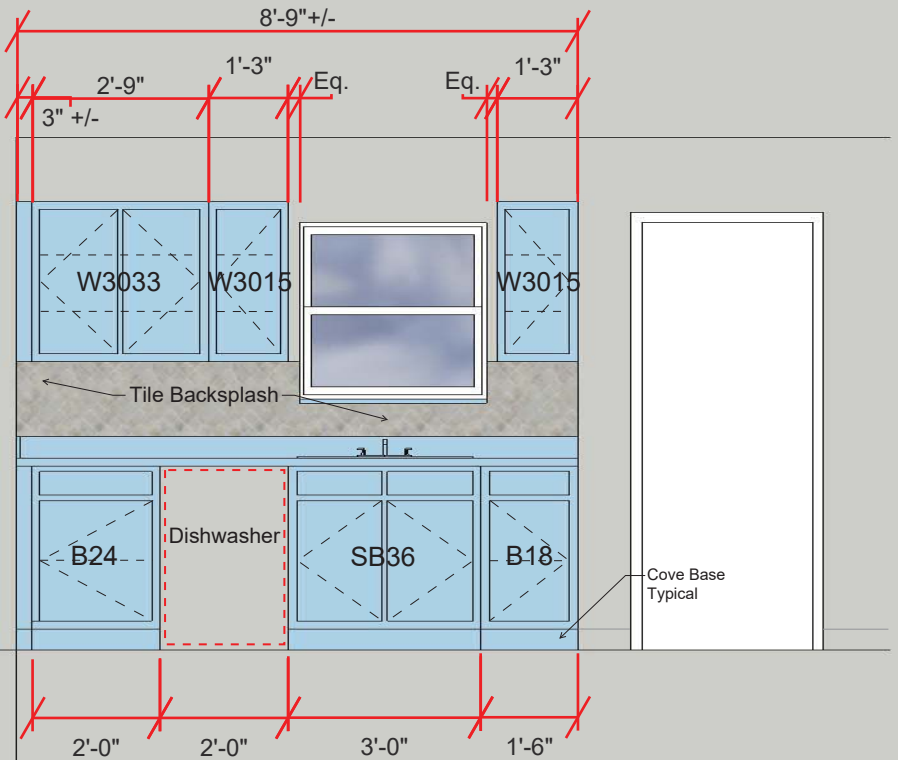

### KITCHEN ELEVATION

N.T.S.

(C)



Lucas Metropolitan Housing Authority (LMHA)

PRE-BID WALK-THRU  
SIGN-IN SHEET

546 Vance, Toledo, OH

Wednesday, May 22, 2019, 2:00-3:00 PM

NAME	COMPANY	ARRIVAL TIME	EMAIL
1. HOWARD ZIBBEL	DELVENTHAL	2:00	HZIBBEL@THEDELVENTHAL.COM
2. Bill Kroma	SEI	2:00	BillK@Surfaceenterprises.com
3. DJ MARRANO	MARRANO CONST	2:15	djmarran@gmail.com
4. Luther Terry	<del>SEI</del> TNT Anchor	2:30	VictorTerry35@gmail
5. Denny MARRANO	MARRANO CON.	2:15	
6.			
7.			
8.			
9.			
10.			