

Addendum No. 2

East Pages Siding Replacement

TO: All Plan Holders

FROM: Sherman Carter Barnhart Architects
2405 Harrodsburg Road
Lexington, Kentucky 40504

DATE: May 18, 2021

The purpose of this Addendum is to clarify further the requirements of the plans and specifications.

The bidders are governed by the information in this Addendum as if included in the plans and specifications.

This Addendum does hereby become a part of the Contract Documents.

Each bidder shall acknowledge receipt of this Addendum in the space provided in the Bid Form.

This Addendum consists of (10) ten, 8-1/2"x11" pages.

This Addendum is being made available to all plan holders through online Housing Agency Market Place.

A. Attachments

1. On May 4, 2021 at 10:00 a.m. a virtual Pre-Bid Meeting was held at the LMHA Purchasing Department. The minutes and sign-in sheet of that meeting are attached and shall become part of the Contract Documents.
2. The attached drawing Sheet ADD2.1 – Revise Detail 9/A-4 per the attached drawing ADD2.1.

B. General (All Bidders are advised of the following)

1. **CLARIFICATION** – Bid Bond shall not be less than five percent (5%) of the amount of the bid per Specification Section B form HUD-5369, Section 9 – Bid Guarantee.
2. **CLARIFICATION** – Progress Payments are to be made approximately every 30 days as the work proceeds, on estimates of work accomplished which meets the standards of quality established under the contract. Refer to Specification Section I form HUD-5370, Section 27 – Payments.
3. Where referenced within the Contract Documents and Meeting Minutes, the following work items shall be OMITTED and shall NOT be part of the contract:
 - a. Testing and proper operation and pressures of air conditioners, compressors and refrigerant safeties (high and low pressure switches).
 - b. Cleaning of condensing coils.
 - c. Reporting defective units and repairs.

- d. Removal (and temporary capping) of refrigerant lines and recovery / recycling of existing refrigerant.
- e. Removal and replacement of condensate lines (and mounting brackets).
- f. New refrigerant lines (and mounting brackets) and recharging with refrigerant.
- g. Insulation and protective taping of new refrigerant piping.
- h. Relocation of refrigerant piping in exterior soffit (detail 11, sheet A-4).
- i. Leveling of existing mechanical units and pads (note 4 of Site Scope of Work, sheet S-2).

Work noted above will be performed by LMHA. The Contractor is responsible to coordinate schedule for work by others.

- 4. **ADDITION** – Refer to Sheet S-1, Building Exterior Scope of Work. Add note 15 - Contractor to paint all exterior exposed gas piping.
- 5. **MODIFICATION** - Reduce the quantity of topsoil for fill (identified in note 2 of "Site Scope of Work", sheets S-1 & S-2) from 75-CY to 60-CY. Per remark above leveling of existing mechanical units and pads is omitted. Other work described in note 2 (fill around buildings, splash blocks and areas of ponding water) remain in the work.
- 6. **CLARIFICATION** – Bidders are to refer to the LMHA website – housing agency marketplace for the project bid opening Zoom meeting link.

End of Addendum



PRE-BID MEETING MINUTES

RE: East Pages Complex Apartments
Siding Replacement
Proposal No. 1548
Louisville Metro Housing Authority
SCB Project No. 2128

DATE: May 4, 2021
10:00 am local time

PRESENT: Virtual Meeting

On this date, a virtual pre-bid meeting was held for the referenced project. Below is a summarization of items discussed.

1. Introduction

- a. The bid opening date is **May 25, 2021 at 10:00 a.m.** by the clock in the "Purchasing Department Conference Room" and are due at LMHA Purchasing Department, 3223 South Seventh Street Road.

Bids are NOT to be delivered to the project site.

Bids are to be received in triplicate; one original and two copies.

- b. The project team is as follows:

- Mrs. Norma Ward, LMHA
- Mr. Mike Lyall, LMHA
- Mr Phil Reidinger, LMHA
- Mrs. Jill Schloemer, LMHA
- Mr. Tom Smith, Sherman Carter Barnhart Architects

2. Clarifications and Addendum

- a. The Pre-Bid Meeting Minutes will be incorporated into subsequent Addenda.
- b. Last Addendum will be issued on **May 18, 2021**.
- c. Any questions regarding the solicitation procedures are to be directed to Mr. Mike Lyall at lyall@lmha1.org and any questions regarding the technical documents are to be directed to Tom Smith at tsmith@scbarchitects.com in writing, by **May 18, 2021 by 10:00 am**.

Sherman Carter Barnhart Architects
2405 Harrodsburg Road
Lexington, KY 40504

859 224 1351 Office
859 224 8446 Fax
scbarchitects.com

After this date and time, through the bid opening and bid award process, all communication must be directed to Mr. Webb at 569-6693, or email webb@lmha1.org

- d. Site Visit – Contractor may review buildings at East Pages Complex Apartments during normal business hours 9:00 am – 3:00 pm, Monday – Friday; all bidders are expected to follow the guidelines from the CDC, State and local authorities regarding the ongoing Coronavirus (COVID-19) Outbreak. Management will be notified on potential bidders visiting sites.

3. **Contract Documents – Scope of Work**

- a. A brief overview of East Pages Complex Apartments Siding Replacement includes but is not limited to the following.

The project consists of a single site at East Pages Lane. The buildings are occupied and will remain so during construction. The Construction Type for all buildings is 5B and work must comply with 2018 KY Building Code. There are no known hazardous materials requiring abatement.

Typical building work includes removal and replacement of building wrap / siding / soffits / trim with new fiber cement siding and removal and replacement of sheet metal gutters and downspouts. Existing infill at openings for former mechanical units are to be replaced. Screen walls at 1-story units are to be removed and replaced. Work includes limited new signage and extra materials for sheathing. Also, limited tuckpointing is required at existing brick rowlocks along with pressure-wash cleaning of existing brick veneers.

Mechanical work involves the removal and rerouting of the existing exterior refrigerant lines at the 2-story units only. Existing insulation jackets to be removed and replaced at all exterior locations. Existing dryer vent caps are to be removed and replaced.

Electrical work involves the removal and replacement of existing exterior lighting. Existing visual and audio alarms on 1-story units are to be removed and replaced.

Limited site work involves landscape trimming as needed for work, minor grading improvement, leveling of existing mechanical pads and lawn restoration of affected yards.

Site is occupied

- b. ~~Project time: (270) Calendar Days~~
- c. A job site office trailer is optional.
- d. Work hours are 8:00 am – 4:00 pm, Monday through Friday. No overtime work will be allowed.
- e. General Contractor is responsible for weekly payroll reports, including their subcontractors. Payroll reports are to be submitted every two (2) weeks to LMHA. Do not submit payroll reports to architect.
- f. Contractor is responsible for State and local permitting, coordinating with Utility Companies, etc.

- g. Official Bidding Documents are available from the Louisville Metro Housing Authority's e-procurement Marketplace, free of charge. Their website is as listed in the Advertisement for Bid, or visit our web site at www.lmha1.org and follow the link under bid opportunities. There is no cost to receive plans/specifications from this agency.

4. Contract Documents – Bid Documents

- a. Both the "numerical" and "written" descriptions of the bid total must match. The Housing Authority will have to make a ruling on such a situation if it develops.
- b. The contractor is responsible to read, examine and understand all sections of the Project Manual.
- c. All bid proposals should be submitted in triplicate, using the "Official Bidding Documents", which contain the following components:
- Section B "Form of HUD 5369-A"
 - Section D "Form of Bid".
 - Section E "Supplemental Bid Information".
 - Section M (pages 15-24).
 - 5% Bid Bond must be submitted with the Bid, and the Bonding Company must be an approved Bonding Company
- d. Prior to submitting the "Official Bidding Documents" bidders are to verify that the inserted forms are for this project. Bidders are to confirm that all pages for all sections are included; if there is a missing page, immediately contact Mike Lyall.
- e. Instructions for submitting the bid proposal are included in Sections B, C, D, and E of the Project Manual ("Front End").
- f. SECTION C (Supplemental Instructions to Bidders):
- Refer to Items IV and XII to determine being a responsive and responsible bidder.
 - Contractors are directed to Section "C", especially page 7 of 7. The apparent low bidder will be required to submit the "second day bid documents" by 10:00 am the day after the bid opening date.
- g. SECTION F (Form of Contract)
- Will Only be submitted by the successful low bidder; however, it is highly recommended all prospective bidders read these sections.
- h. SECTION G (Form of Material/ Labor Payment Bond)
- Will Only be submitted by the successful low bidder; however, it is highly recommended all prospective bidders read these sections.
- i. SECTION H (Form of Performance Bond):
- Will Only be submitted by the successful low bidder; however, it is highly recommended all prospective bidders read these sections.
 - Liquidated Damages will be **\$1,000.00** per calendar day.
- j. SECTION I (General Conditions)
- Suggest all Contractors read the General Conditions.
 - The definition of "sub-contractors" may be obtained in SECTION I, page 13, #37.

- Contractors are encouraged to read numeral #39 regarding EEO and numeral #40 regarding Section 3 Programs.
- k. SECTION J (Supplemental General Conditions):
 - Carefully read all instructions.
 - All conditions of the project manual apply to the contractor and all sub-contractors.
 - Contractor and Subcontractor must have an Insurance Certificate and must be kept in force for the duration of contract.
- l. SECTION K (Federal Davis-Bacon General Wage Decision)
 - The wage decision determination for the project is, as described on SECTION K
 - Payrolls need to be submitted weekly. Or this will hold up Contractor's application for payment.
 - General Contractor is responsible for Subcontractor's weekly submission of payrolls as well.
- m. SECTION L (Special Conditions):
 - Carefully examine all "Special Conditions".
 - Project completion time is listed in this section.

5. **Contract Documents – SECTION M**

- a. It is important to comply with all the requirements in SECTION M, FAILURE TO COMPLY IS GROUNDS FOR BID REJECTION.
- b. Remember: SECTION M is mandatory for consideration of the contractor's bid.
- c. Thoroughly read SECTION M including information concerning SECTION 3 regulations. (ENCORAGE) all potential bidders to call or email me with any questions regarding the intent of SECTION M, if not fully understood.
- d. Contact information is:
 - Office phone number: (502) 569-4922
 - Office fax number: (502) 569-3459
 - Mailing address: 420 S. 8th Street, Louisville, KY 40203
 - Email address: reidinger@LMHA1.org
- e. MBE, FBE & DBE participation goals for this project.
 1. MBE goals are 25%
 2. FBE goals are 10%
 3. DBE goals are 0.5%

"Waiver Request" shall be included in 2nd day submittals sent to Phil Reidinger and shall be made in compliance with SECTION M, Part I. H.

- f. If a bidder does not intend to use sub-contractors on the project, the MBE, FBE and DBE Participation Goals do not apply. If a bidder does not intend to use sub-contractors, state as such.

- g. If a bidder intends to use sub-contractors on the project, MBE, FBE and DBE Participation Goals apply; and the bidder must list all proposed subcontractors in the space provided in the "Official Bid Documents" forms.
- h. **IN ORDER TO BE CONSIDERED RESPONSIVE**, a bidder must either meet the goals (if applicable) or provide evidence conclusively demonstrating that it made a strenuous, albeit unsuccessful, good faith effort to meet the goals. Failure to aggressively respond to these requirements is grounds for rejection of bid as non-responsive. Waivers must be included with the Bid.
- i. MWDBE Prime Contractor must perform at least 12% of the contract work with its own forces.
- k. Materials and Supplies can only be toward MWDBE participation goals if the Supplier is an MWDBE certified Business. Any only at 605 of the total cost for Wholesaler and Retailers. MWDBE Manufacturers may be counted at 100% toward the participation goals. MWDBE may count reasonable mark up on supplies but may not count payment for services like bonding, storage facilities, equipment rental, or other incidental services not performed by their own employees (unless the service is performed by an MWDBE certified business).
- l. Certification documents are required for all of the MWDBE contractors with the 2nd day submittal information.
- m. Bidders are responsible for making sure the Demographics are correct for the employees listed, and completely filled out. If you are unsure, list all employees.
- n. MWDBE must be certified prior to bid opening and must provide a certificate that is in force for the duration of the project.
- o. Waiver requests for the MBE, FBE, DBE goals shall be submitted with the 2nd Day Submission documents, after the bid opening. An example of a waiver is included in Section M, page 10-13 part H. Separate waivers are required for each MBE, FBE or DBE goal.
- p. If a bidder requests a partial waiver, the (%) of the waiver must be stated.
- q. Make sure all forms are legible and that forms do not contradict each other. Do not leave any blanks.
- r. The contractor is encouraged to read Section 3.
- s. The contractor is encouraged to read Section 3.
 - 1. 30% of the new hire employees used to conduct work on this project shall be Section 3 Residents.
 - a) Low Income
 - b) LMHA Residents
 - c) YouthBuilding participants.
 - 2. Request for new hires must be approved by LMHA.
 - 3. 10% of the contract amount shall be awarded to Section 3 Business Concerns like:

- a) Subcontractors
 - b) Material suppliers
 - c) Consultants
4. The SECTION 3 clause outlined in page 29 must be included in the contract, likewise the Section 3 clause must be included with any contract with subs.
 5. The SECTION 3 plan format on pages 31 thru 40 must be filled out legibly and completed by the general contractor and each sub if they are the successful bidders.
 6. Bidders can visit the HUD website.
(<https://portalapps.hud.gov/Sec3BusReg/BRegistry/SearchBusiness>),

Or Google "Hud Section 3 Business Registry" and select "Search for Business" search the Louisville Metropolitan Area, then you can even narrow your search to say FBE, Section 3 Businesses

To see qualify Section 3 Business Concerns.

6. Bidders are reminded of important dates for the project:

- Deadline for submitting MBE, FBE, and DBE questions or waiver request to Mr Phil Reidinger is **May 18, 2021 by 10:00 am.**
- Deadline for submitting questions regarding the solicitation procedures is **May 18, 2021 by 10:00 am.** (E-mail or fax).
- Deadline for submitting questions regarding the technical specs is **May 18, 2021, by 10:00 am.** (E-mail or fax).
- Bid opening date and time is **May 25, 2021, at 10:00 a.m.**

END OF PRE-BID MEETING MINUTES

X:\Projects\2021\2128\2128 Pre-Bid minutes.docx



SIGN-IN SHEET FOR:

PRE-BID MEETING via Zoom

4715 East Pages Siding Replacement

PROPOSAL NO. 1548

DATE: TUESDAY, May 4, 2021
TIME: 10:00 a.m.

	<u>NAME</u>	<u>DEPARTMENT/COMPANY</u>	<u>TELEPHONE</u>	<u>FAX</u>
1	Ron Craycraft	Martin Construction Co	502-802-8342	
2	Steve Whitney	Whitney Consulting	502-645-8797	
3	Cory Bailey	Bailey Construction	502-749-1586	
4	Mark McQuillen	Howell & Howell	502-491-7985	
5	Terry Hanson	Payne Electric Company	502- 968-9171	
6	Phil Reidinger	LMHA	502-569-4922	reidinger@lmha1.org
7	Jill Schloemer	LMHA	502-569-4505	schloemer@lmha1.org
8	Tom Smith	SCB	859-806-7241	
9	Mike Lyall	LMHA	502-569-4044	lyall@lmha1.org
10				
11				
12				
13				
14				

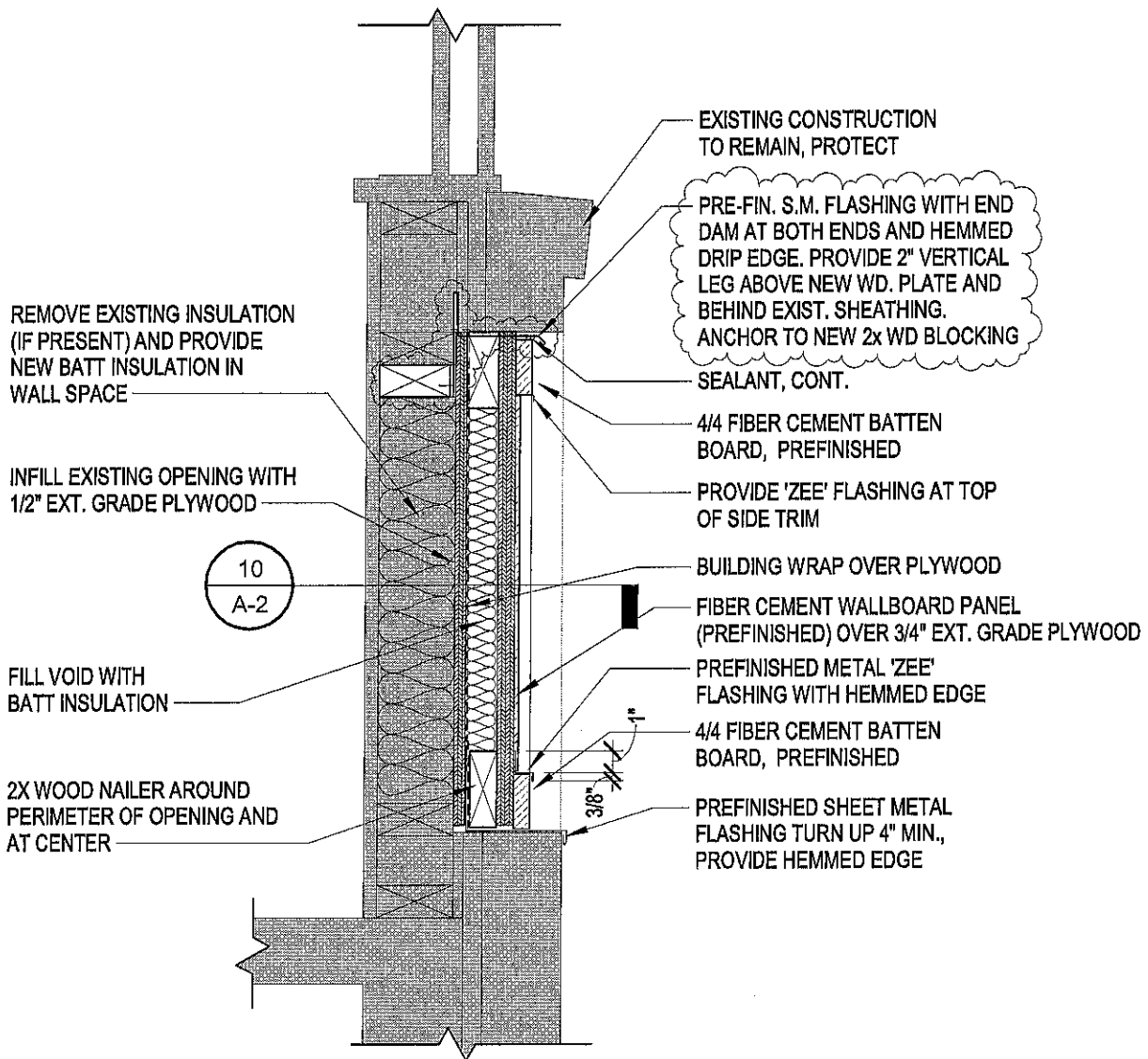

NOTE: REMOVE EXISTING PANEL PRIOR TO INSTALLATION OF NEW MATERIAL

1 **DETAIL**
1 1/2" = 1'-0"

ADDENDUM NO. 2 - REVISED DETAIL 9/A-4



**COPYRIGHT © 2021
SHERMAN CARTER BARNHART
ARCHITECTS, PLLC**

JOB NO.	2128	SHEET NO.	ADD2.1
PROJECT NAME	LMHA EAST PAGES SIDING REPLACEMENT	DATE	05/18/21
PROJECT LOCATION	LOUISVILLE, KY	DRAWN	MM